

(12) PATENT
(19) AUSTRALIAN PATENT OFFICE

(11) Application No. AU 199647568 B2
(10) Patent No. 713409

(54) Title
Test apparatus, system and method for the detection of test samples

(51)⁶ International Patent Classification(s)
C12Q 001/66 C12M 001/34

(21) Application No: **199647568** (22) Application Date: **1996.01.02**

(87) WIPO No: **WO97/03209**

(30) Priority Data

(31) Number	(32) Date	(33) Country
60/001081	1995.07.12	US
60/007585	1995.11.27	US

(43) Publication Date : **1997.02.10**

(43) Publication Journal Date : **1997.04.10**

(44) Accepted Journal Date : **1999.12.02**

(71) Applicant(s)
Charm Sciences, Inc.

(72) Inventor(s)
Richard Skiffington; Eliezer Zomer

(74) Agent/Attorney
DAVIES COLLISON CAVE, 1 Little Collins Street, MELBOURNE VIC 3000

(56) Related Art
EP 155747
US 3713780

OPI DATE 10/02/97 APPLN. ID 47568/96
AOJP DATE 10/04/97 PCT NUMBER PCT/US96/00524



AU9647568

(T)

<p>(51) International Patent Classification⁶ : C12Q 1/66, C12M 1/34</p>	<p>A1</p>	<p>(11) International Publication Number: WO 97/03209 (43) International Publication Date: 30 January 1997 (30.01.97)</p>
<p>(21) International Application Number: PCT/US96/00524 (22) International Filing Date: 2 January 1996 (02.01.96) (30) Priority Data: 60/001,081 12 July 1995 (12.07.95) US 60/007,585 27 November 1995 (27.11.95) US (71) Applicant (for all designated States except US): CHARM SCIENCES, INC. [US/US]; 36 Franklin Street, Malden, MA 02148 (US). (72) Inventors; and (75) Inventors/Applicants (for US only): SKIFFINGTON, Richard [US/US]; 33 Linden Street, Everett, MA 02149 (US). ZOMER, Eliezer [IL/US]; 374 Kenrick Street, Newton, MA 02158 (US). (74) Agent: CROWLEY, Richard, P.; P.O. Box 901, 901 Main Street, Osterville, MA 02655-0901 (US).</p>		<p>(81) Designated States: AU, CA, JP, US, European patent (AT, BE, CH, DE, DK, ES, FR, GB, GR, IE, IT, LU, MC, NL, PT, SE). Published <i>With international search report.</i> <i>With amended claims.</i></p>

(54) Title: TEST APPARATUS, SYSTEM AND METHOD FOR THE DETECTION OF TEST SAMPLES

(57) Abstract

The invention concerns a test apparatus (10) for the testing of a test sample on or in a material, such as body fluids or food, particularly adapted to a bioluminescent test, such as for the detection of ATP or phosphatase or other materials. The test apparatus (10) includes a transparent tube having at one end a sample unit (14), at the other end a detachable or nondetachable test unit (16) which are connected, and which includes a cover (12) with a probe containing a swab (18) at one end. The test apparatus (10) includes probe positioning marks (22) on the exterior of the sample unit (14), so that the probe may be moved between selected test positions, and as it moves from a non-use to a use position, various test reagents which are sealed within the test unit (16) are punctured by the probe, and the test sample and the test reagents are reacted together in the test unit (10).

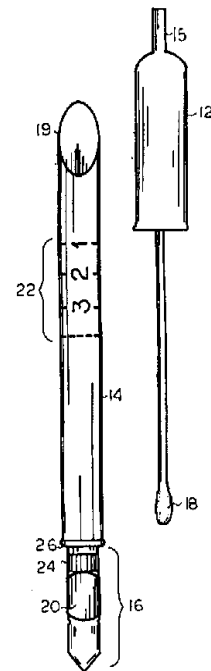

**Test Apparatus, System and Method
for the Detection of Test Samples**

Description

Reference to Prior Applications

5 This application claims the benefit of provisional U.S. patent application Serial No. 60/001,081 filed July 12, 1995, and also the benefit of provisional patent application Serial No. 60/007,585, filed November 27, 1995.

Background of the Invention

10 It is desired to provide for a rapid and efficient test for the detection of various test samples from materials or surfaces. Various test apparatuses and test methods have been developed for that purpose. For example, it is widely desirable to determine or to test through quantitative and
15 qualitative tests body fluids, such as blood, urine, milk and the like, as well as food, such as meat products, fruit, vegetables, and to detect for alkaline phosphatase, salmonella, drugs, and antibiotics, such as; for example, sulfa drugs, beta-lactam drugs, organophosphates, carbamates
20 and active metabolites, various bacteria and pathogenic combinations, either in materials or on the surface of materials, or both.

For illustration only, the detection and characterization, qualitatively and qualitatively, through
25 the employment of a color change or a bioluminescence test, for the detection of the alkaline phosphatase, such as for example, the detection of ATP on or in materials, is most desirable for providing a measure of immunoeffectiveness, so that a rapid determination can be made of whether a
30 processing or surface area is adequately hygienically clean and free of, for example, alkaline phosphatase, so that corrective or disinfectant action can be instituted.

Typically, the detection of ATP is by bioluminescence assay, which is a standard test which will detect food

residue, bacteria, yeast, mold, by measuring the ATP on a surface. The method comprises obtaining a test sample, for example, on the surface of the material, such as by non-laboratory or out-of-laboratory or at field locations, the
5 activating of the test sample in the presence of test reagents, and then later employing a luminometer to determine test results, which can be compared with a controlled sample or controlled environment.

The detection of a phosphatase, like ATP, may be made in
10 a dimensional color test and method. However, such a test is time consuming and requires laboratory trained personnel. The present commercial tests are generally directed to a bioluminescence test, which ordinarily takes less than five minutes and employs premeasured and prepackaged separate test
15 reagents and employs a luminometer to detect test results. Generally, a portable luminometer, as used in the field, with the use of test containers, such as various test tubes or plates. The concentration of the phosphatase has been determined by measuring or counting of the bioluminescence,
20 determined by the reagents mixing with the test sample, and comparing the count against certain accepted control standards, or a threshold of a control standard.

There are various ATP tests available in the field, and one bioluminescent ATP monitoring test in present use is
25 described in "The Handbook of ATP-Hygiene Monitoring" by Bio-Orbit Oy of Turku, Finland, while another luminescent ATP hygiene monitoring test in use is called the Charm ABC Swab Test™, sold by Charm Sciences, Inc., of Malden, Massachusetts, both of which tests and literature are hereby
30 incorporated by reference.

Another portable swab-type device for use in an ATP bioluminescent test for measuring cleaning effectiveness is distributed under the mark Lightning™ swab device by Idexx

Laboratories, Inc., of Westbrook, Maine. (Lightning™ is a trademark of Idexx). The Lightning™ device consists of an integral swab design, which contains a unit dose of reagents in use with a portable luminometer. The device employs an
5 elongated tube with a cover on it at one end and an elongated, extended premoistened wetting agent on a premoistened swab, and with such end containing a buffer in a bulb, while the opposite read chamber end, where the test results are read, comprises a glass ampoule. The ampoule
10 contains a luciferin and luciferase reagent material, with a glass ampoule separating the read chamber from the buffer end. The swab is removed from the tube and is used to obtain a test sample from a surface to be tested for ATP, and then the swab is reinserted within the tube.

15 The cover end of the device is then met and squeezed to force out the buffer solution, while the opposite end containing the glass ampoule with the reagents, is crushed by the user so that the buffer solution and the crushed luciferin-luciferase test reagents are then admixed within
20 the tube with the test sample to form the reaction mixture, which would provide for the appropriate bioluminescence. The read chamber at one end is inserted into and read by the portable luminometer. Thus, the Lightning™ device provides a swab-type test probe requiring the bending and squeezing of
25 one end and the crushing of a glass ampoule at another end of the device, then the admix of the materials prior to inserting the read chamber into a luminometer and then reading the test results. The Lightning™ swab device, together with its test methods, literature and equipment, is
30 hereby incorporated by reference.

It is desirable to provide for a new and improved test apparatus, system and method adapted for use with a wide variety of known and unknown test methods for the detection

of test materials on a material or on a surface. The improved test apparatus is greatly simplified in structure and is effective in use, eliminates possible operational mistakes by personnel in the field, does not require separate
5 pipettes and test tubes, does not provide for the crushing of glass ampoules with its inherent danger, and provides excellent separate stability of test reagents which may be employed with the test results by specifically prepackaging the reagents, so that the test apparatus may be stored for
10 long periods of time prior to use.

The device is particularly adapted for in-field or out of the laboratory testing by unsophisticated personnel, as well as the use by laboratory personnel, and further and importantly may have the test results determined by using the
15 entire test results in one end thereof, or removing one end of the test unit for testing in a test instrument, which may be, for example, a visual change of color, or other property, in some tests, a use of a portable luminometer, or the use of other types of test instruments including radioactive
20 detection devices, either alone or in any combination. The improved test device is particularly adaptable as a disposable, inexpensive, transparent, plastic pocket test apparatus.

Summary of the Invention

25 The present invention concerns a test apparatus and a test system employing the test apparatus, and a test method employing the test apparatus and system, and in particular in one embodiment is directed to a bioluminescent type test for the detection of test samples from a material or material
30 surface, by employing known test techniques.



- 4A -

According to one aspect of the invention there is provided a test apparatus for the detection of a test sample from or on a material, which apparatus comprises:

- a) an elongate tubular sample unit having:
 - i) a probe means having a first and second end, with said first end to
5 obtain a test sample in use to be collected from or on a material;
 - ii) a chamber having a first and second open end and adapted to receive and retain therein prior to use and after use said probe means and having a cover for said first end of said chamber; and
 - iii) means to move threadably and longitudinally said first end of said probe
10 means within said chamber to selected sequential non-use and use positions; and
- b) a tubular test unit longitudinally aligned and attached to the second end of the chamber and having:
 - i) a transparent housing having a first end and a second closed end, said
15 first end attached to said second end of said chamber, said transparent housing adapted for use with or in a test instrument or visual observation for the identification of the test sample by color or luminescence; and
 - ii) test sample reagent means to contact the test sample on said probe
20 means and comprising a plurality of membrane-sealed reagent compartments, each characterized by a puncturable sealing membrane adapted to be penetrated by the threadably longitudinal movement of said first end of the probe means, the test sample and the reagent means in combination when mixed providing a selected test for the detection of the test sample in the test unit when the test sample and the reagent means are combined in said transparent housing.

According to another aspect of the invention there is provided a method for the
25 detection by a user of a test sample from or on a material, in which said test sample is combined with test reagents to provide test results, which method comprises:

- a) providing an elongated, tubular, test apparatus with a sample unit constructed and arranged to obtain a test sample and to retain a probe means having a probe end therein, and a transparent closed end test unit at one end;
- 30 b) removing said probe means and collecting the material to be tested to obtain a test sample on the probe means;



- c) inserting said probe means within said test apparatus;
- d) threadably moving said probe means in said test apparatus, with said test sample, between a starting non-use position with the probe end within the sample unit and a use position with the probe end in the test unit;
- 5 e) puncturing two or more packaged test reagents in membrane-sealed compartments, the reagents selected for the particular test method for the sample, by the downwardly threadable movement of the probe end of the probe means to provide a contacting and mixing of said test reagents and said test sample from said probe means in said test unit; and
- 10 f) observing a change in color or luminescence within said transparent test unit.

According to a further aspect of the invention there is provided a test apparatus for the bioluminescent determination of ATP in a test sample, which test apparatus consists essentially of:

- a) an elongated tubular sample unit having:
 - 15 i) a probe means having a first and a second end with said first end comprising a premoistened swab to obtain a test sample;
 - ii) a chamber having a first end and a second end and adapted to retain and receive, after obtaining the test sample, the said probe means and having a cover for the first end with the second end of the probe means attached thereto; and
 - 20 iii) threadable means to move longitudinally said first end of said probe means within said chamber to selected sequential positions; and
- b) a tubular test unit longitudinally aligned and attached to the second end of the chamber having:
 - i) a transparent housing with a closed bottom end adapted for use with a
25 test instrument to measure emitted bioluminescence within the housing; and
 - ii) ATP test sample reagent means comprising in sequence sealed reagent packages, each characterized by a swab puncturable membrane to include; a release solution for the release of the ATP in the test sample on the swab; a buffer solution; and a luciferin-luciferase composition, the reagent means with the ATP containing test sample on the swab
30 combined in the bottom housing unit to provide for a bioluminescence ATP detection test.



According to yet another aspect of the invention there is provided a method for the bioluminescent determination of ATP in a test sample, which method comprises:

- a) providing a test apparatus with a sample unit having an enclosed chamber and a top cover with a probe means of a premoistened swab at one end within the chamber and
5 a transparent test unit at another end of the sample unit and containing a plurality of separate membrane puncturable sealed test reagent package means;
- b) removing the probe means from the chamber;
- c) collecting a test sample from a material or surface to be tested for sanitation;
- d) inserting the swab with the test sample back into the sterile chamber;
- 10 e) threadably longitudinally moving the cover with the swab and collected test sample in the sterile chamber to puncture with the swab sequentially the membrane sealed reagent package means of an ATP release solution and, a buffer solution, and to permit the resulting admixed test sample with release solution and buffer solution to contact a luciferin-luciferase composition in the bottom of the test unit to provide a bioluminescent ATP test;
- 15 f) threadably longitudinally removing the swab from the test unit; and
- g) measuring the amount of bioluminescence in the test unit to determine the amount of ATP in the test sample.

The invention comprises, in certain embodiments, a test apparatus composed of a sample unit and a test unit, which sample and test units may be generally longitudinally
20 aligned and secured together



generally in tubular form, and which may be integral or may be disposed for the removable detachment of the test unit by the user. The test apparatus is employed for the detection of the qualitative or quantitative, or for any analytical
5 test of one or more test samples from or on a material or on a material surface.

The test apparatus comprises a sample unit having a probe means, such as an elongated element having a first and second end, with the first end adapted to obtain a test
10 sample with a test collection swab or means at one end, used to be collected from or on a material, and generally would comprise a probe-type collection means at one end, by which a test sample may be collected, and a sterile chamber having a first and second end and adapted to receive and retain
15 therein prior to use, and optionally after use, the said probe means, and having a cover for the first end of said chamber to seal the end of the chamber.

The sample unit also includes means to retain said probe means within said chamber prior to use; that is, to render
20 the test apparatus sterile prior to use, and without indiscriminate movement of the probe means within the chamber. The sample unit also includes a probe positioning means, comprising a plurality of selected identification positions between the probe means and the chamber in order to
25 identify the relative position of the probe means, and particularly the first test end of the probe means, within said chamber or within said test units, both before and after use. The sample unit also includes means to move a cover end, having the probe means move generally longitudinally to
30 the first end of the probe means, in relationship to said chamber, typically over or within said chamber for use, to one, or typically a plurality of, selected identification positions as required in the particular test method and

apparatus.

The test apparatus also includes a test unit attached to a sample unit, generally longitudinally aligned and attached to the sample unit and having at its bottom end a reagent housing, which is optionally generally transparent, so that a luminometer or visual test result observation may be made, and having a first end and second bottom end, the first end attached to said second end of the chamber in the sample unit, and the housing adapted for use alone or integrally with the test apparatus, so that the test results may be observed in the reagent housing, or the reagent housing may be detached and used in a test instrument, or to conduct tests on the admixture therein, or the entire test apparatus, together with the reagent housing, employed in a test instrument, such as the bottom end placed in a luminometer or other instruments for the detection of the test sample.

The test unit also includes a test sample reagent means, which comprises preselected reagents depending on the desired test to be carried out, and when one or more tests may be carried out alone or in any sequence as desired, with the test reagent means designed to contact the test sample collected. The reagent means generally comprises at least one sealed reagent package containing a test reagent, which may be solid, liquid, powder, emulsion suspension tablet or substantially any combination separately or admixed thereof.

There may be and usually is a plurality of separate sealed reagent packages, depending on the particular test method selected for the test sample. The test sample reagent means is characterized as being adapted, arranged and constructed, so as to be displaced, punctured penetrated or unsealed by the longitudinal movement of the first end of the probe means to a selected identification position so as to

permit the admixture or combination reaction or otherwise contacting the test sample on the probe means, and the one or more reagents which have been released from the sealed reagent action of the reagent means.

5 Generally, the reagent means is characterized by a package having a puncturable foil seal or membrane, which is adapted to be penetrated by the movement of the probe means, or by other means after collection of the test sample by the probe means, and with the one end of the probe means moved to
10 a selected identification position, so as to generally sequentially, puncture the aligned, sealed reagent packages in the desired sequence as desired. The puncturing occurs at progressive, selected identification positions, usually which positions are marked on the outside of the chamber for easy
15 observation by the user. In some test methods, as desired or required, sequentially contacting of test reagents is desired, while in other tests the sequence is not of importance. Generally the reagents are also packaged and separated in order to provide for better storage life.
20 Generally, two, three, four, or five or more test reagents or combinations in a package are employed, and would include, for example, at least one liquid reagent, either water or a buffer solution or a neutralizing solution, and then one or more powdered or tablet type packages, so that as the test
25 sample as the probe means is pushed downwardly, it comes in contact with each of the selected reagents, with the test reagents and test samples admixed at the bottom end of the test unit. A test reagent, packaged or unpackaged, may also be placed in the bottom end of the test unit, such as a
30 solution or tablet to be admixed with the other reagents and test samples.

The test apparatus, containing the sample and test units, is composed, for example, of an elongated

thermoplastic, transparent, flexible, plastic (like polyethylene) tube, having a cover, with an elongated semi-rigid probe exposed within the sterile chamber of the tube, and a transparent test unit end at the other end and
5 containing therein the prepackaged test reagents. This apparatus is well adapted for use in the field by generally untrained personnel to obtain test samples from or in a wide variety of materials. The test apparatus may be composed of a disposable, transparent tube material that is easily
10 carried by a user in a pocket or briefcase to the field or plant as required, and usually may be disposed of in toto, or where the test unit is removed from the bottom and then is sealed, may be used in a portable luminometer, which thus makes disposal of the test apparatus quite easy, without
15 undue contamination of the atmosphere.

Generally, the probe means comprises an elongated, somewhat flexible, usually semi-rigid plastic element secured at second end to said cover, and which cover is mounted over the one end of the chamber, typically slidably but also for
20 removable, helical or other longitudinal movement within the chamber. The probe means contains a test sample collection material secured at the one end, such as, for example, a fibrous type material such as a cotton swab, which may, if desired, be premoistened, such as by a water or an aqueous
25 wetting solution, or with other compositions such as color indicators, dyes, reagents or test reagents, or merely may contain chemicals which physically or chemically bind to the material to which the test is directed. Generally, the first test end of the probe means is liquid-moistened, such as by
30 water or a wetting agent solution, particularly when it is used for the collection of test samples on materials or surfaces, to determine hygiene cleanliness, in order to aid in the collection of the test sample on the surface.

The test apparatus is provided to the user with a sample and test units together and with the sterile probe means within the sterile chamber of the sample unit. The probe means is originally in a non-use position, so it does not
5 longitudinally move until after the collection of the test sample by the user. The probe means is then moved sequentially to the selected identification positions. Optionally and preferably the test apparatus includes some means to retain the probe means in the original, selected
10 non-use position, prior to use by the user, such as the use of an adhesive tape wrapped about the one end of the cover and the chamber, which is user removable, and the use of an easily breakable adhesive, or the use of a heat shrinkable material, such as a transparent plastic material which may be
15 shrunk around the one end of the cover and the chamber or the entire test apparatus to render it sterile until use, to preposition the probe means within the sterile chamber prior to use.

The test apparatus includes probe position means, in
20 relationship between the sterile chamber and the one end of the cover containing the probe means, in one acceptable and preferential method of use. The probe position means generally would comprise any type of means by which the one end of the cover containing the probe means is moved
25 longitudinally in relationship to the test unit which contains the reagent means. Thus, in one example and preferably, the chamber may contain a series of spaced-apart, generally parallel identification lines or marks, either marked by colors or numbers or both, or by some
30 identification means, whereby the bottom portion of the cover containing the probe means and prior to the removal of the retaining means is prepositioned, and then user-moved relative to the marks on the chamber.

The test instructions then permits the obtaining of the test sample using the probe means on a material or a surface, and reinserting the probe means within the chamber, to a selected, usually first non-use, non-reagent identification
5 mark, or in the one end of the probe chamber, and does not extend beyond the second end of the chamber, that is, the test end is above the test unit. The probe position means then provides for the longitudinal, slidable or helical movement of the cover means with the test probe, to say, a
10 second position, third or fourth or multiple positions, whereby the one end of the probe means then contacts the respective reagent test means positioned in the test unit. This provides for contact of the test sample of the probe means with the test reagents, so that all of the test samples
15 or reagents are then contained and admixed within the test unit at the one bottom end of the test apparatus. Generally, the final probe position means is such that all of the test reagent unit means have been punctured down at the one end, and the one end of the probe means is disposed slightly
20 within the test unit. The probe may then be twirled to ensure good contact with the reagents, and then withdrawn to the original or a non-use position within the chamber for later use or disposal. Typically, the sample unit is within the chamber, so that the test apparatus, the sample unit, or the
25 sample and test unit all together may be readily and easily disposed of in an acceptable manner.

The position probe means should be well-marked and typically uncomplicated, so that the probe position means may be easily understood and used by people in the field.

30 The means to move the one end of the probe means may vary; so long as the probe means is moved longitudinally within the chamber between non-use and selected use positions, and from the one end of the chamber into the test

unit, for example, by the employment of a slidable longitudinal movement when the cover is placed in a snug, close-fitting sliding position over the one open upper end of the chamber of the sample unit, or where there are helical or spiral grooves placed on the inside of the cover, or on the outside of the chamber unit or both, to provide for the spiral movement to a selected probe position means, or where merely bumps or other means are employed so that the user may move the probe means easily to the selected positions.

Of course, it is also recognized that where there is only a test sample at the end of a probe and only one reagent, it may well be that no probe position means are required, other than for use or non-use, and the probe merely, after a test sample is placed in the chamber, and merely longitudinally moved downwardly to contact a single reagent to force the reagent then to contact the test sample directly into the test unit for test or observation. This would indicate the use of a very simple test method, and typically would not lend itself, for example, to the bioluminescent-type method for determining enzymes like phosphatase, or for the use of beta-lactams, or in processing of meat, or for determining sulfa, drug residues or organophosphate residue on products.

In another embodiment, the test apparatus may comprise a single tube with a cover, wherein the entire test apparatus, after the test sample on the longitudinal movement of the probe means, is employed in its entirety in determining the test results, that is, the test unit is not either made or detached or removable from the one end of the sample unit, but is for example, securely attached thereto, for example, by being integrally molded therewith. In such a situation, the test unit at the one end can still be inserted into a luminometer, or other test instrument, and

the color or other change affected by the test results observed or read. Thus, as desired, the entire test apparatus can be disposed of in an effective and environmentally non-toxic manner.

5 In another embodiment, which will be illustrated, the test unit at the one end of the test apparatus can be detachably removed in any manner thereto, such as employing threads, or slidably fit, or a weakened mechanical section or other means, or merely just taping the units together, so
10 that after movement of the probe to selected identification positions, then the removal of the probe means to the non-use position, the test unit at the one end of the test apparatus may be easily twisted or removed by the user, and would then contain therein the test samples of the various reagents, in
15 an admixture. In this particular method of operation and structure, the test unit, which occupies only a small volume at one end, may then be detached and inserted, for example, into a portable field-type luminometer, so this test method lends itself quite readily to the use of portable test
20 instruments and use in the field or non-laboratory environments. Where this test method is employed it is often desirable to provide a means to seal the one open end of the test unit after removal from the test apparatus. This can be accomplished by a variety of means; for example, by employing
25 a screw-type or plug-in type cap secured to the test apparatus, or by more conveniently using a removable adhesive detachable seal, for example, which may be secured to the test apparatus and readily removed by the user after detachment of the test unit, and then placed over the open
30 end of the test unit and wrapped around to cap the open end of the test unit. Such a seal, for example, may comprise but not be limited to: an aluminum foil, which is adhesively sealed on one side, or any other means to cap, seal or

otherwise secure the one open end of the test unit.

It is sometimes desired to provide, rather than a generally cylindrical tube for the test apparatus, a tube wherein the plastic is flexible, particularly toward or near
5 the one of the test unit, so that a user may then squeeze the one end of the tube generally intermediate the test unit and the sample unit, so as to insure the test sample on the probe means is squeezed out together, for example, with the premoistened reagent liquid and contacts the test reagents
10 fully before the one end of the squeezed, used probe means is withdrawn into the chamber.

The reagent housing which is used generally is transparent, particularly where a visual observation is desired; however, it is recognized that the reagent housing
15 may be non-transparent, particularly where the particular test to be carried out does not require transparency of the housing or test unit. The test sample reagent means, which is placed generally in the test unit or in the chamber adjacent the open end of the test unit, is adapted to be
20 punctured or pushed by one end of the probe, and provides powdered, liquid, tablet or suspensions of one or more or a combination of chemicals, materials and reagents to the test unit as desired by any particular test.

Usually, the test reagents would generally comprise from
25 two to five separate sealed reagent packages, at least one or more of which packages would be a liquid package, such as a water or buffer solution or a saline solution. It is desirable to place in at least one of the test sealed reagent packages an individual dye or combinations in each package,
30 so that the user is insured that the test probe punctures each package and that the dye color is present in the reagent housing.

Generally, for example, the sealed reagent package,

particularly where the test unit is generally cylindrical, would comprise a plurality of spaced apart, separately sealed test reagents containing one or more test reagents, the package so designed, so as to be penetrated, punctured or dispersed by one end of the probe means on longitudinal movement, to provide for contact between the contents of the package and the test sample. The probe means penetrates a puncturable or rupturable membrane, which is placed on at least one side, and typically on opposing sides of a generally cylindrical package, or in fact where a tablet is used, is designed to break up a powdered tablet, in contact with the liquid solution and the test sample.

Generally, the sealed reagent package comprises a plurality of generally separate, individual packages with one or more test reagents having puncturable sealed membranes and opposite radial sides thereof, all selected to be punctured at selected identification positions by the probe positions, to provide for adequate contact between the test sample at the end of the probe means and each of the reagents, so that the entire mixture or content thereof, would end up in the reagent.

The number, type, material concentration and form of the test reagents in each package, or alone, may widely vary. For example, the test reagents may contain a dried microorganism or other microorganisms, growth and enhancing indicators, such as detergents, ethylene diamine, tetraacetic acid, enhancing reagents to enhance the test results, such as pH or dye color indicators, buffer solutions, saline solutions, water solutions, enzymes, material which bioluminesces, such as luciferin alone and in combination with a luciferin derivative, or with other materials which provide biolumination, as well as low level radioactive isotopes, for example a beta-lactam test, stabilizers,

antioxidants, phosphatates and phosphatase substrates, various biological buffers, material such as a chromogen which acts in the presence of an enzyme, and a wide variety of other materials.

5 The test apparatus, for example, may be used in test methods to determine phosphatase, ATP, beta-lactams, pesticides, bacteria such as coliform and E.coli, etc (see, for example, tests described in U.S. Patents 4,239,745, 4,239,852, 5,200,311, 5,283,180, 5,354,663, and 5,374,535, 10 incorporated herein by reference.

The invention comprises a method for the detection of a test sample from or on a material, which method includes providing a test apparatus with a sample and test units, collecting a test sample by use of a probe means which is 15 stored in a sterile chamber within a sample unit, and thereafter using the probe means, for example, containing a test swab with an end thereof, which may be premoistened so as to collect a test sample. Thereafter, the method includes using the probe means within a chamber to puncture one or 20 more test reagent means, so as to provide for contact within a test unit at one end of the test apparatus of the test samples with one or more test reagents, so that the test method can be carried out, and with the probe moved longitudinally between selected probe positions within the 25 test apparatus.

The method also includes employing a test unit, either individually or by the use of instruments, either alone or as an integral part of the test apparatus, to do the test detection. Any test method may be typically employed in the 30 test apparatus, the selection of a particular test and test reagents known to persons skilled in the art depending on the particular test.

The apparatus is composed of two units, the sample unit

and the test unit. In one embodiment, the test unit is an integral part of the apparatus and does not need to be removed for final reading of results. Instead, the whole apparatus is inserted to the luminometer for reading.

5 Another embodiment, which calls for removal of the test tube unit for analysis, may be used because of the portable luminometer constraints. The analyzer, e.g. luminometer, can accommodate the whole apparatus, and therefore better and more simply contain all chemicals in the apparatus for
10 disposal. The cover/chamber sliding mechanism can be controlled after testing by a spiral or raised portion on the plastic in order to control the position and/or speed of or stop the downward motion of the probe, and control the timing for each chemical reaction. Some tests will require the use
15 of a timer to allow the full reaction to take place on a timed basis.

The sample unit contains a sterile chamber housing the probe, made of disposable plastic and composed of a chamber cover that holds the probe and the chamber for the probe,
20 which can be made of metal or other materials. The cover and chamber are sealed prior to use to prevent downward movement of the cover, moving the probe into the chamber. A simple sealing mechanism is used, such as heat shrink plastic or paper that can be torn by a simple twist, to open the chamber
25 and cover and retrieve the probe for sampling.

The chamber is comprised of a waterproof housing to enable the probe material to be maintained moist with the proper solution and ready to use.

The probe may be a swab-type device, made of plastic,
30 wood or metal, with the tip made of absorbent material such as cotton, or synthetic material (plastic), or a hollow tube; e.g., a disposable pipette. The tip may be used to obtain a sample by a capillary or vacuum suction, or an affinity probe

that can adsorb the analyte by bioaffinity binding; e.g., antibodies or receptors, may also be used.

The unit may also contain instructions and a control mechanism, by which the probe, after the sampling step, is
5 inserted into the testing unit and longitudinally moved to puncture the membranes and allow penetration of each reagent container.

In an optional embodiment, a squeezing mechanism may be desired for full recovery of the sample and products of the
10 interaction of the sample and the reagents. In this embodiment, the chamber's opening is narrowed to enable the swab, when withdrawn to the non-use position, to squeeze out all liquids into the test microtube for best recovery of color/luminescence products, or a flexible plastic tube
15 squeezed about the probe means capping the apparatus.

The test unit is essentially a transparent test tube (plastic or glass) that contains the active components of a selected test with the test sample. Each chemical is contained within a small cylinder; e.g. a reagent chamber,
20 and inserted in the housing and both top and bottom are sealed with a water- and chemical-resistant membrane made of aluminum foil, plastic or waxed paper, or a combination of the above.

The membrane is thin enough to be fractured, burst, or
25 punctured by the probe with a slight pressure by the user. The reagents are packaged in the reagent chamber in liquid, dried powder or tablet forms. The number of reagents may vary as required for each test method selected; for example, from one to five ingredients, depending on the test
30 requirements.

Optionally, indicator dye is included with the early reagent (e.g. in the first Reagent A), the first penetrable reagent. This helps to verify that all the chemical

interactions during the test are working properly. When the dye is visible in the test housing, it is an indicator of a used device.

The test apparatus system and method will be described
5 for the purposes of illustration only in connection with a series of illustrative test apparatus and test method employing various test apparatus. However, it is recognized that those persons skilled in the art may make various modifications, changes, additions, and improvements to the
10 test apparatus, system and methods without departing from the spirit and scope of the invention.

Brief Description of the Drawings

Fig. 1 is an elevational view of the test wand apparatus
15 of the invention.

Fig. 2 is a sectional view along line 2-2 of the apparatus of Fig. 1.

Fig. 3 is an elevational view of the apparatus of Fig. 1 with the plunger removed.

20 Fig. 4 is an elevational view of the apparatus of Fig. 1 with the microtube removed and capped.

Fig. 5, with schematic illustrations 5A - G, shows the steps of the test method employing the apparatus of Fig. 1.

25 Fig. 6 is an enlarged, fragmented, sectional view of the lower section of the apparatus of Fig. 1 in the non-use position.

Fig. 7 is an enlarged, exploded, fragmented view of the microtube and reagent packages of the apparatus of Fig. 1.

30 Fig. 8 is an elevational view of another embodiment of a threadable test wand apparatus of the invention, with Fig. 8A showing the apparatus with the cover removably secured to the chamber, and Fig. 8B showing the apparatus with the cover removed.

Description of the Embodiments

Fig. 1 shows the test wand apparatus 10, comprised of transparent, semi-rigid molded polyethylene, with cover/plunger 12 being secured around and outside of elongated sterile sample unit cylinder 14. A microtube test unit 16 is attached to the bottom end of the sample unit cylinder 14, the microtube test unit 16 having indentations 26 and finger grips 24 to enable a user to manually grasp and remove the microtube test unit 16 from the sample unit cylinder 14.

A swab 18 (shown in broken line) is inserted into the interior top end 15 of the cover 12 and removably secured therein. A generally circular aluminum foil seal 20 is positioned on the exterior surface of the microtube test unit 16 and is removably adhered by self-adhesive backing to the microtube 16. Indicator lines 22 are shown on the upper end of the sample unit cylinder 14. The bottom end of the cover 12 and the top end of the sample unit cylinder 14 are secured together with a heat-shrunk plastic seal 17, and removably secured around the periphery of the cover 12 and sample unit cylinder 14, to prevent downward movement of the cover 12 when the apparatus is in a non-use position.

In the sectional diagram of Fig. 2, the apparatus of the invention 10 is shown with the cover 12 having the swab 18 removably inserted into the interior of top end 15 of the cover 12. The top of the sample unit cylinder 14 is shown with an angular, elliptical cut 19 thereon. A swab 18 is inserted into the interior top end 15 of the cover 12 and removably secured therein. Fig. 2 also shows the microtube test unit 16 with inner containment system 49 having units 30 and 32 and space at the bottom 34, the units containing Reagent A 36, Reagent B 38, and Tablet C 40 respectively. Puncturable membranes 74, which separate each unit of the

inner containment system 49, are also shown.

Fig. 3 shows the apparatus 10 with the cover 12 removed from the sample unit cylinder 14, the microtube test unit 16 still attached to the end of the sample unit cylinder 14. A swab 18 is inserted into the interior top end 15 of the cover 12 and removably secured therein.

Fig. 4 shows the apparatus 10 with the microtube test unit 16 detached from the sample unit cylinder 14 and sealed with the adhesive-backed, aluminum foil seal 20.

Fig. 5 shows the apparatus 10 of Figs. 1-4 in use. Fig. 5A shows the apparatus 10 prior to use, with cover 12, sample unit cylinder 14 and microtube test unit 16 attached. Fig. 5B shows the cover 12 withdrawn from the sample unit cylinder 14, with the swab 18 obtaining a test sample from surface area 48. Fig. 5C shows the cover 12 being reinserted into the sample unit cylinder 14, and being moved downwardly longitudinally to the first of the indicator marks 22. Fig. 5D shows the cover 12 being further depressed into the sample unit cylinder 14 at the second of the indicator marks 22.

Fig. 5E illustrates the cover 12 being depressed in a downwardly longitudinal manner fully within the sample unit cylinder 14 to moisten the tablet at the bottom of the microtube test unit 16. Fig. 5F shows the microtube test unit 16 after removal from the sample unit cylinder 14, with the adhesive-backed aluminum foil seal 20 being sealed over the microtube test unit 16. Fig. 5G shows the microtube test unit of Fig. 5F being inserted into a luminometer 44 and counted with a counter 46 for testing of the sample.

Fig. 6 depicts an enlarged view of the bottom end of the apparatus 10 with the microtube test unit 16. The swab 18, premoistened with swabbing solution, is moving longitudinally and downwardly toward the first prepackaged containment unit 30 with a microbial lysis solution and ATP stabilizer. The

second prepackaged containment unit 32 is shown with the buffer optimized for luciferin-luciferase reaction, and the luciferin-luciferase Reagent tablet 34 is shown in the bottom of the microtube test unit 16.

5 **Fig. 7** shows in further detail the single use sequential unit dose containment system 49, with plastic cylinders 30 and 32 containing Reagent A 36 and Reagent B 38. Tablet 42 is shown in position below the units. Puncturable membrane seals 74 for the separation of the containment units are also
10 illustrated. The system 49 is shown prior to insertion into the microtube test unit 16. While in the preferred embodiment for the detection of ATP the above-mentioned reagents are utilized, it is recognized that other combinations of reagents and detection products may be used
15 for specific alternate applications of the test apparatus as shown and described.

Fig. 8 illustrates another embodiment of the test apparatus 50, with cover/plunger 52 having a rounded top end and threads 56 on the interior surface of the open bottom end
20 of the cover 52. These threads 56 are threadably fit to the threads 58 on the outside of the open upper end of the sample unit cylinder 54. A swab 70 is removably inserted into the interior of the top end of the cover 52. This embodiment also depicts a microtube test unit 60 removably secured to
25 the sample unit cylinder 54 with a peripheral indentation 66 and finger grip 64 to enable the user to detach the microtube test unit 60 from the sample unit cylinder 54. A plastic heat shrunk seal 72 secures the sample unit cylinder 54 and cover 52, and an adhesive-backed aluminum foil seal 62 is
30 removably secured to the exterior surface of the microtube test unit 60. The aluminum foil seal 62 is used to cap the microtube test unit 60 in a secure fashion after it is detached from the sample unit cylinder 54 for testing.

Indicator lines 68 allow the user to control the turning of the cover 52 with the threads 56 to enable the swab 70 to be longitudinally downwardly inserted into the prepackaged reagent containment system 60.

5 **Fig. 8A** illustrates the apparatus 50 in a non-use position, and **Fig. 8B** shows the apparatus 50 in a use position with the cover 52 removed for obtaining a test sample. The reagent containment system 60 in **Fig. 8** may be
10 comprised of the same reagent combinations as illustrated in **Figs. 1-4**, or may be any other combination of reagents and
chemicals as desired for testing.

In use, the test apparatus is used by removing the heat-shrunk plastic seal 17 securing the cover 12 to the sample unit cylinder 14, and removing the cover 12, which cover has
15 a premoistened swab 18 removably secured into the interior of the top 15 of the cover 12. After swabbing/sampling the affected area being tested, the cover 12 and swab 18 with the
sample are re-inserted into the sample unit cylinder 14. The sample unit cylinder 14 has three indicator markings 22 on
20 its exterior surface. When the cover 12 with swab 18 is re-inserted into the sample unit cylinder 14, it is moved downwardly longitudinally to the second mark, and the cover
is twirled twice, breaking into the first containment unit 30 with Reagent A 36. The cover 12 is then moved downwardly
25 longitudinally to the third mark and twirled twice more, breaking into the second containment unit 32 with Reagent B 38. The plunger is then depressed fully in a downwardly
longitudinal manner, breaking into the bottom chamber 34 with Reagent tablet C, and is then twirled, moistening the reagent
30 tablet C 42 at the bottom of the microtube test unit 16. The cover 12 with swab 18, having all three reagents thereon and mixed with the sample on the swab, is withdrawn upwardly and
longitudinally into the sample unit cylinder 14.

The microtube test unit 16 is then detached, if desired, from the sample unit cylinder 14 at break point 26 by means of the finger grips 24. After removing the adhesive-backed aluminum foil seal 20, the microtube test unit 16 is then
5 covered with the adhesive cap 20 and counted, such as by a luminometer 44 (see Fig. 5). To ensure proper reacting of all samples, the semi-rigid plastic sample unit cylinder may also be squeezed by hand.

After testing, the entire apparatus 10 may be easily
10 disposed of. Further, before use, the entire test apparatus 10 may be easily carried and stored in the user's pocket or a portable, lightweight carrying case. The unique single use sequential unit dose containment system 49 within the microtube test unit 16 allows for easy storage and
15 portability, without mixing of the reagent chemicals and possible spoilage of the chemicals therein.

The following examples are provided to illustrate optional uses of the sample and test kit apparatus and method:

20

EXAMPLE 1

Total Hygienic Test - Total sanitation ATP monitoring test kit: Pocket Swab™, (a trademark of Charm Sciences, Inc.,
25 Malden, Massachusetts). The swab contains water or cleaning solution (e.g. detergent, such as an anionic-like sodium lauryl sulfate, a non-ionic like Triton X-100, a quaternary ammonium like benzalkonium chloride at 0.01-0.3%, for swabbing biofilm and dried microbial film.

30 The chamber's ingredients are Buffer A: (0.1-0.3 ml) buffer containing phosphoric acid 0.05% and anionic detergents (0.1%) for rapid release of ATP from microorganisms. The buffers could be acids: e.g.,

trichloroacetic acid or phosphoric acid at 0.01-0.5%, pH 1-3 (e.g. 0.1% phosphoric acid pH 2 and 0.5% Triton X-100), or neutral to alkaline pH buffers such as tris, tricine or carbonate. Detergents can be anionic (sodium lauryl sulfate), neutral (Triton X-100) or cationic (like quaternary ammonium).

The indicator dye: pH indicator such as phenol red (PR) or bromocresol purple (BCP) at 0.0001-0.001%, just enough to be visible to the naked eye. The BCP is yellow in Buffer A, it changes to blue in Step 2 when B and A are mixed, and remains blue in Step 3 when A and B are mixed with Reagent C.

Buffer B is comprised of a neutralizer buffer to optimize the luciferin-luciferase reaction, e.g. 0.05-0.2M of tris, tricine or other biological buffers. Optionally, it is possible to combine Buffer A with Buffer B.

Tablet C contains luciferase and luciferin substrate for detection of ATP. These ingredients are stabilized in a tablet format (see U.S. Patents 4,239,745, 4,239,852, 5,200,311, 5,283,180, 5,354,663, and 5,374,535, incorporated herein by reference).

EXAMPLE OF RESULTS ENCLOSED AS APPENDIX 1: Sanitation results (RLU) vs. the presence of various microorganism on surfaces in a processing food plant.

APPENDIX 1

Table Example of results for the PocketSwab in processing food plant

SPC - standard plate count for total aerobic bacteria
 CFU - colony forming unit
 COLI - coliforms bacteria
 ATP - adenine nucleotide triphosphate
 RLU - relative light unit

LOCATIO #	Sanitation level	PocketSw ATP (RLU)	SPC CFU	YEAST CFU	MOLD CFU	COLI CFU	Total microbia CFU
1	Good	0	0			0	0
2	Good	0	140	6	0	0	146
3	Good	0	0	0	0	0	0
4	Good	0	0	0	4	0	4
5	Good	0	0	0	0	0	0
6	Good	0	0	0	0	0	0
7	Good	0	0	0	0	0	0
8	Good	0	0	0	0	0	0
9	Good	0	0	0	0	0	0
10	Good	0	20	2	3	0	25
11	Good	0	0	0	0	0	0
12	Good	0	0	0	0	0	0
13	Good	0	0	0	0	0	0
14	Good	0	0	0	0	0	0
15	Good	0	0	0	0	0	0
16	Good	0	0	0	0	0	0
17	Good	0	0	0	0	0	0
18	Good	0	0	0	0	0	0
19	Good	0	10	0	0	0	10
20	Good	0	0	0	0	0	0
21	Good	0	0	0	0	0	0
22	Good	0	10	0	0	0	10
23	low	594	50	0	0	0	50
24	low	647	10	16	4	0	30
25	low	1347	210	8	0	0	218
26	low	2292	110	0	0	10	120
27	low	2437	388	0	0	0	388
28	low	2969	100	0	0	0	100
29	low	3267	2440	23	1	0	2464
30	low	3959	0	0	0	0	0
31	low	3989	0	0	0	280	280
32	low	4460	0	0	0	975	975
33	med	4889	13000	5	0	24	13029
34	med	6697	30	15	0	0	45
35	med	6975	13000	0	0	26	13026
36	med	7174	580	8	32	36	656
37	med	7275	10	123	10	0	143
38	med	8075	460	101	72	0	633
39	med	10625	190	0	52	0	242
40	med	10972	180	2	4	0	186
41	med	15830	300	187	2	0	489
42	med	28067	30	9	164	32	235
43	med	32009	3900	0	0	2	3902
44	med	42685	112	0	3	0	115
45	high	53712	6500	650	455	17	7622
46	high	59019	19500	0	1300	0	20800
47	high	130837	16250	520	178	46	16994
48	high	175154	19500	0	6500	0	26000

EXAMPLE 2

Testing residual raw milk/meat/fish. This test measures the activity of phosphatase as indicative of raw tissue, milk or serum in cooked produce (e.g. pasteurized milk, cooked meat salami, cold cuts, smoked fish). It also can be used to detect cross-contamination from raw material in processing surfaces and equipment intended for finishing products.

Commercial name - CHEF Test™ (a trademark of Charm Sciences, Inc., of Malden, Massachusetts). ALK Test™, Cross-contamination test.

The swab can be dry for sampling wet surfaces, or is moistened with water/buffer for meat products and solid dairy products, like cheese.

The chamber ingredients include in Chamber A, a water or saline buffer, pH 6-10 with preservatives (e.g. benzoic acid, sorbate), and a pH indicator such as phenol red at 0.001%.

The second chamber contains tablet MP, with Tropix phosphatase substrate (CPD, a product of Tropix, Mass.), freeze dried and made into a tablet.

Chamber 3 contains a stopping solution (0.0025-0.025M EDTA, 0.05-0.2M Tris base or other biological buffers, 0.1-0.3 NaCl, pH 8-11).

EXAMPLE OF RESULTS AS ENCLOSED IN APPENDIX 2: Study of CHEF Test™ Performance in testing cooked ground beef hamburgers.

APPENDIX 2**Study of CHEF Test™ Performance
in Heat Processing of Ground Beef**

Purpose: To demonstrate the CHEF (Cooking Heat Efficiency) Test™'s performance, precision and accuracy in predicting doneness of cooked ground beef. Inadequate cooking has been the major cause of stomach poisoning from pathogenic bacteria like E.coli and salmonella.

10 **Introduction:** The CHEF Test™ uses the presence of phosphatase activity to determine whether cooked meats have met CFR specified cooking temperatures. Acid phosphatase as an indicator for cooking has been reported in previous literature.

15

Principle: The CHEF Test™ uses a chemiluminescent substrate for rapid determination of phosphatase activity. The procedure includes the sampling step, which includes using a wet swab to sample the core of the meat (after splitting the meat sample to expose the inner core). Also, it can be used to swab an equipment surface (e.g., a slicing machine), or other surfaces to test for residual raw meat/milk. In the incubation step, the swab is brought into contact with the chemiluminescent substrate, e.g., CSPD, a Tropix product, for one to ten minutes at a temperature range from room temperature to 65°C, for example, 55°C for one minute. At the reading step, the reaction is terminated and stabilized by adding a stopping solution and immediately counting relative light units using a luminometer.

Results: The average CHEF Test™ for raw beef is in the range of 15,000 to 20,000 RLU, while fully cooked beef gives results in the range of 0-300 RLU (see Table 3).

Results for ground beef heated to various temperatures and hold times are listed in Table 2.

Discussion: Using the results for fully cooked meat, a cut off for determining incompletely cooked meat can be set at the upper range (e.g. 300 RLU). In our field samples (Table 3) all the hamburgers were properly cooked (all results below 300 RLU). In our own cooking experiment, (Table 2), we effectively screen low temperature cooked products (Samples 1-4) from adequately processed and cooked products (Samples 5 and 6).

Conclusion: The CHEF Test accurately detects raw meat and also can distinguish fully cooked meats from incompletely cooked meats. Meat processed at a temperature 2°C below CFR specifications and for thirty seconds too short a time (Sample 4), was identified as positive in this study. Samples properly processed, and hamburgers purchased from a local restaurant, were negative for residual raw meat.

APPENDIX 2

Table 2. CHEF Test results (RLU) of various ground beef samples held at various temperatures and times.

Temp. °C (°F): Hold Time ->	Sample #1	Sample #2	Sample #3	Sample #4	Sample #5	Sample #6
Replicate #	RLU	RLU	RLU	RLU	RLU	RLU
#1	10536	12490	11622	2795	10	123
#2	17784	22940	5481	3903	0	0
#3	14325	8411	5040	2113	0	0
#4	11979	6309	17881	2060	0	0
#5	21310	12832	10475	4969	186	0
#6	21426	6264	11022	5766	188	227
Average	16227	11541	10254	3601	64	58
+/- Range	4676	6285	4704	1542	95	96
% activity	95	68	60	21	3.8	3.4

A dozen hamburgers purchased at a local food chain tested on the CHEF Test are reported in Table 3.

Table 3. CHEF Test (RLU) of Hamburgers from Restaurant

Hamburger #	CHEF (RLU)	Hamburger #	CHEF (RLU)
1	0	7	37
2	0	8	0
3	0	9	0
4	0	10	0
5	0	11	0
6	0	12	0

EXAMPLE 3

5 Chemical and antibiotic residue test - Testing of residual antibiotics in milk, urine, and meats.

The swab is dry for sampling of water, milk, meat serum or urine.

10 The chamber ingredients are comprised of water or 0.005-0.1 phosphate buffer pH 5-8 in Chamber One. In Chamber Two, the tablet contains dried microorganisms, such as naturally luminescent bacteria such as *P. phosphoreum*, (Canadian Pat #1103050) or, genetically modified bacteria (e.g. *E.coli* mutant used in the Toxi-Chromotest EBPI, Ontario, Canada); a growth and maintenance nutrient (see USP5,354,663
15 incorporated herein by reference), and a growth or activity indicator like chromogen, which in the presence of an enzyme, such as D-galactosidase or phosphatase, can produce color or luminescence (e.g., Tropix luminescence substrates: CSPD, Galacton-Plus).

20 Chamber Three contains an enhancing reagent, such as fluorescamine or Tropix enhancing reagents (Emerald, Sapphire).

The procedure for this test comprises obtaining a test sample with the probe means, inserting the swab into the
25 buffer compartment, inserting the swab into the buffer compartment, inserting it into the tablet compartment, and the inserting the swab into the chromogen. It should be noted that the tablet and chromogen can be contained in a single compartment.

30 The test samples should be incubated for 1-120 minutes and the luminescence then recorded. Inhibition of luminescence indicates the presence of a chemical inhibitor in the sample. For example, using *E.coli* and Tropix Galacton-plus substrate in E*Colite/ColiGel™ media (a
35 trademark of Charm Sciences, Inc., of Malden, Massachusetts),

can be used to detect antibiotics such as quinolones, and others. Using *Bacillus stearothermophilus*, a variety of antibiotics can be detected in about 60-120 minutes using color change or change in luminescence substrate.

5 Each test kit is fully packaged all in one device, including the reagents, which greatly simplifies the test, making it user-friendly. The test utilizes simple steps which are controlled by the plunger and indicator marks, and has puncturable seals, such as aluminum foil seals, that
10 separate the various compartments. It eliminates the need to prepare reagents, and no pipettes or dispensers are needed. This device eliminates operational mistakes due to inaccurate pipettes. Since all the reagents, liquid and tablets, are individually packaged and sealed, under optimum conditions,
15 the test kit has excellent shelf life stability, with an expectation of over two month's stability at room temperature. The test device can be easily carried and used in any place, for example, in a processing plant, without restrictions.

20 Thus, the test apparatus of the invention provides for a safe, convenient, lightweight and inexpensive test apparatus that may be stored for longer periods and easily transported for use. Further, the invention is easy, neat and convenient to use. The prepackaged single use sequential
25 unit dose containment system allows for fewer user errors in preparing reagent chemicals for use. While the single use packaging system of the invention is shown and described herein for the testing of ATP for sanitation purposes, it is recognized that the apparatus, system and method may be used
30 for a wide variety of product applications.

Throughout this specification and the claims which follow, unless the context requires otherwise, the word "comprise", and variations such as "comprises" and "comprising", will be understood to imply the inclusion of a stated integer or group of integers or steps but not the exclusion of any other integer or group of integers or steps.

2
2
2



THE CLAIMS DEFINING THE INVENTION ARE AS FOLLOWS:

1. A test apparatus for the detection of a test sample from or on a material, which apparatus comprises:

a) an elongate tubular sample unit having:

5 i) a probe means having a first and second end, with said first end to obtain a test sample in use to be collected from or on a material;

ii) a chamber having a first and second open end and adapted to receive and retain therein prior to use and after use said probe means and having a cover for said first end of said chamber; and

10 iii) means to move threadably and longitudinally said first end of said probe means within said chamber to selected sequential non-use and use positions; and

b) a tubular test unit longitudinally aligned and attached to the second end of the chamber and having:

15 i) a transparent housing having a first end and a second closed end, said first end attached to said second end of said chamber, said transparent housing adapted for use with or in a test instrument or visual observation for the identification of the test sample by color or luminescence; and

20 ii) test sample reagent means to contact the test sample on said probe means and comprising a plurality of membrane-sealed reagent compartments, each characterized by a puncturable sealing membrane adapted to be penetrated by the threadably longitudinal movement of said first end of the probe means, the test sample and the reagent means in combination when mixed providing a selected test for the detection of the test sample in the test unit when the test sample and the reagent means are combined in said transparent housing.

25

2. The apparatus of claim 1 wherein said test unit and said sample unit are comprised of a disposable, semi-rigid thermoplastic material generally cylindrical in shape.

3. The apparatus of claim 1 wherein the chamber includes probe position identification
30 means of a plurality of selected spaced-apart visual marks on the chamber.



4. The apparatus of claim 1 wherein said test reagent means comprises a plurality of test reagents which tend to prereact if directly admixed with said test sample.

5. The apparatus of claim 1 wherein said test reagent means comprises a plurality of test reagents having water or buffer test reagent solution with an indicator dye therein in a first compartment and at least one test reagent for detection of said test sample in the presence of the buffer and dye indicator in a second compartment.

6. The apparatus of claim 1 for the detection of ATP from a material or surface and wherein said first end of said probe means is pre-moistened and said reagent means comprises in separate sealed compartments:

- a) a buffer solution with a detergent to release ATP from the probe means;
- b) a neutralizer solution; and
- c) a tablet which comprises luciferase and a luciferin substrate for the detection of ATP in the sample.

7. The apparatus of claim 1 for the detection of phosphatase from a material or surface and wherein the one end of said probe means is pre-moistened and said test reagent means comprises in separate sealed compartments:

- a) a water or saline buffer solution;
- b) a tablet which comprises a chemiluminescent phosphatase substrate to measure the phosphatase on said test sample; and
- c) a biological buffer solution to stop the reaction of the phosphatase with the test sample.

8. The apparatus of claim 1 for the detection of chemical biocides or antibiotic test samples and wherein the test reagent means comprises in separate sealed compartments:

- a) water or a buffer solution;
- b) a tablet which comprises a microorganism, a nutrient for the microorganism and a growth-activity indicator; and



c) an enhancing reagent to enhance the test results and permit test measurement for detection.

9. In combination, the test apparatus of claim 1 and a photometer to measure the luminescence in said test unit for the detection of said test sample.

10. The apparatus of claim 1 wherein the test unit contains a tablet form reagent means at the closed end.

10 11. The apparatus of claim 1 wherein the test unit includes one or more separate, cylindrical reagent chambers to form a sealed compartment in each chamber, the chamber sealed at each opposite end with a probe-puncturable membrane and the sealed compartment containing test reagent means therein.

15 12. A method for the detection by a user of a test sample from or on a material, in which said test sample is combined with test reagents to provide test results, which method comprises:

a) providing an elongated, tubular, test apparatus with a sample unit constructed and arranged to obtain a test sample and to retain a probe means having a probe end therein, and a transparent closed end test unit at one end;

b) removing said probe means and collecting the material to be tested to obtain a test sample on the probe means;

c) inserting said probe means within said test apparatus;

d) threadably moving said probe means in said test apparatus, with said test sample, between a starting non-use position with the probe end within the sample unit and a use position with the probe end in the test unit;

e) puncturing two or more packaged test reagents in membrane-sealed compartments, the reagents selected for the particular test method for the sample, by the downwardly threadable movement of the probe end of the probe means to provide a contacting and mixing of said test reagents and said test sample from said probe means in said

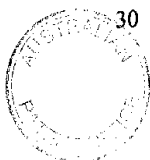

test unit; and

- f) observing a change in color or luminescence within said transparent test unit.

13. The method of claim 12 which includes employing a probe position identification
5 means to identify the position of the probe means in the test apparatus.

14. The method of claim 13 which includes threadably moving said probe means
sequentially to each identification means position.

10 15. The method of claim 12 which includes providing the test unit with a plurality of
separate membrane-sealed cylinder packages of the test reagents.

16. The method of claim 12 which includes measuring with a photometer the amount of
luminescence of said test sample within said test unit.

15

17. The method of claim 12 which includes providing a plurality of packaged test reagents
in said test unit to include a buffer test reagent package, a test reagent package for reacting
with said test sample in the presence of the buffer.

20 18. The method of claim 12 which includes providing a plurality of packaged test reagents
to include:

- a) a buffer solution with a detergent;
- b) neutralizing buffer solution; and
- c) a tablet which comprises luciferase and a luciferin substrate for the detection

25 of ATP in the sample.

19. The method of claim 12 for the detecting of phosphatase from a material which
includes providing a plurality of test reagent packages to include:

- a) a water or saline buffer solution;
- b) a tablet which comprises a chemiluminescent phosphatase substrate to measure

30



the phosphatase of the test sample; and

- c) a solution to stop the reaction of the phosphatase with the test sample.

20. The method of claim 12 which includes providing a plurality of test reagent packages
5 to include:

- a) water or a buffer solution;
- b) a tablet which comprises a microorganism, a nutrient for the microorganism and a growth or activity indicator; and
- c) an enhancing reagent to enhance the test results and permit test measurement.

10

21. The method of claim 12 which includes threadably moving said probe means with a
test sample thereon within the test apparatus sequentially between a non-use position in the
test apparatus with the test sample, a use position wherein the said probe means threadably
sequentially punctures the membranes of the sealed compartments and places the test sample
15 into contact with said test sample reagents to provide a mixture of said test sample and said
reagents within the test unit and a non-use position wherein the said probe means is
withdrawn from the transparent housing.

22. The method of claim 12 which includes placing in selected sequence in the test unit,
20 a plurality of separate, probe-puncturable, membrane-sealed reagent chambers having
membranes at each end, and each chamber containing therein a test reagent.

23. The apparatus of claim 22 wherein the transparent test unit has threads at one end for
removably securing the test unit of the sample unit and wherein the test unit includes a probe-
25 puncturable membrane at the one end to seal the test unit, and the test unit includes one or
more reagent chambers of claim 11 therein.

24. A test apparatus for the bioluminescent determination of ATP in a test sample, which
test apparatus consists essentially of:

- a) an elongated tubular sample unit having:



- i) a probe means having a first and a second end with said first end comprising a premoistened swab to obtain a test sample;
 - ii) a chamber having a first end and a second end and adapted to retain and receive, after obtaining the test sample, the said probe means and having a cover for the first
5 end with the second end of the probe means attached thereto; and
 - iii) threadable means to move longitudinally said first end of said probe means within said chamber to selected sequential positions; and
- b) a tubular test unit longitudinally aligned and attached to the second end of the chamber having:
 - 10 i) a transparent housing with a closed bottom end adapted for use with a test instrument to measure emitted bioluminescence within the housing; and
 - ii) ATP test sample reagent means comprising in sequence sealed reagent packages, each characterized by a swab puncturable membrane to include; a release solution for the release of the ATP in the test sample on the swab; a buffer solution; and a luciferin-
15 luciferase composition, the reagent means with the ATP containing test sample on the swab combined in the bottom housing unit to provide for a bioluminescence ATP detection test.
25. The apparatus of claim 24 wherein the release solution and buffer solution are combined in a single membrane sealed reagent package.
20
26. The apparatus of claim 24 wherein the luciferin-luciferase composition is in stabilized tablet form at the said bottom end of the housing.
27. The apparatus of claim 24 wherein the release solution comprises an acidic solution
25 and the buffer solution neutralizes the test sample release solution.
28. The apparatus of claim 24 wherein the release solution contains a visible dye indicator.
- 30 29. A method for the bioluminescent determination of ATP in a test sample, which method

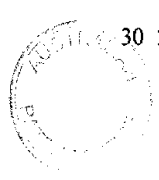

comprises:

- a) providing a test apparatus with a sample unit having an enclosed chamber and a top cover with a probe means of a premoistened swab at one end within the chamber and a transparent test unit at another end of the sample unit and containing a plurality of separate
5 membrane puncturable sealed test reagent package means;
 - b) removing the probe means from the chamber;
 - c) collecting a test sample from a material or surface to be tested for sanitation;
 - d) inserting the swab with the test sample back into the sterile chamber;
 - e) threadably longitudinally moving the cover with the swab and collected test
10 sample in the sterile chamber to puncture with the swab sequentially the membrane sealed reagent package means of an ATP release solution and, a buffer solution, and to permit the resulting admixed test sample with release solution and buffer solution to contact a luciferin-luciferase composition in the bottom of the test unit to provide a bioluminescent ATP test;
 - f) threadably longitudinally removing the swab from the test unit; and
 - 15 g) measuring the amount of bioluminescence in the test unit to determine the amount of ATP in the test sample.
30. The method of claim 29 herein the release solution is acidic and the luciferin-luciferase composition comprises a stabilized luciferin-luciferase tablet.
- 20
31. A test apparatus according to claim 1 or 24 and substantially as hereinbefore described with reference to the drawings and/or Examples.
32. A method according to claim 11 or 29 and substantially as hereinbefore described with
25 reference to the drawings and/or Examples.

DATED this 6th day of OCTOBER, 1999

Charm Sciences, Inc.

by DAVIES COLLISON CAVE

Patent Attorneys for the Applicants



1/4

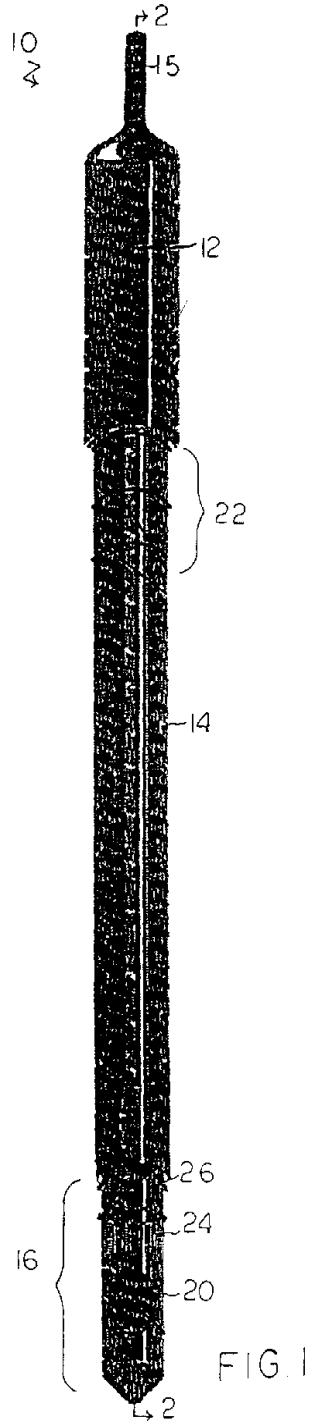

FIG. 1

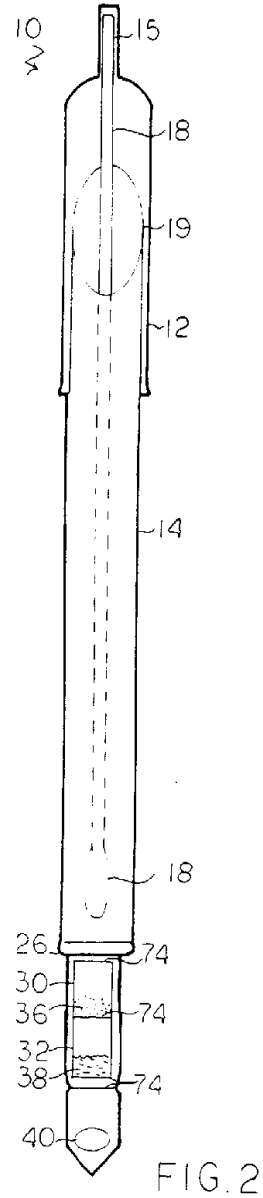

FIG. 2

2/4

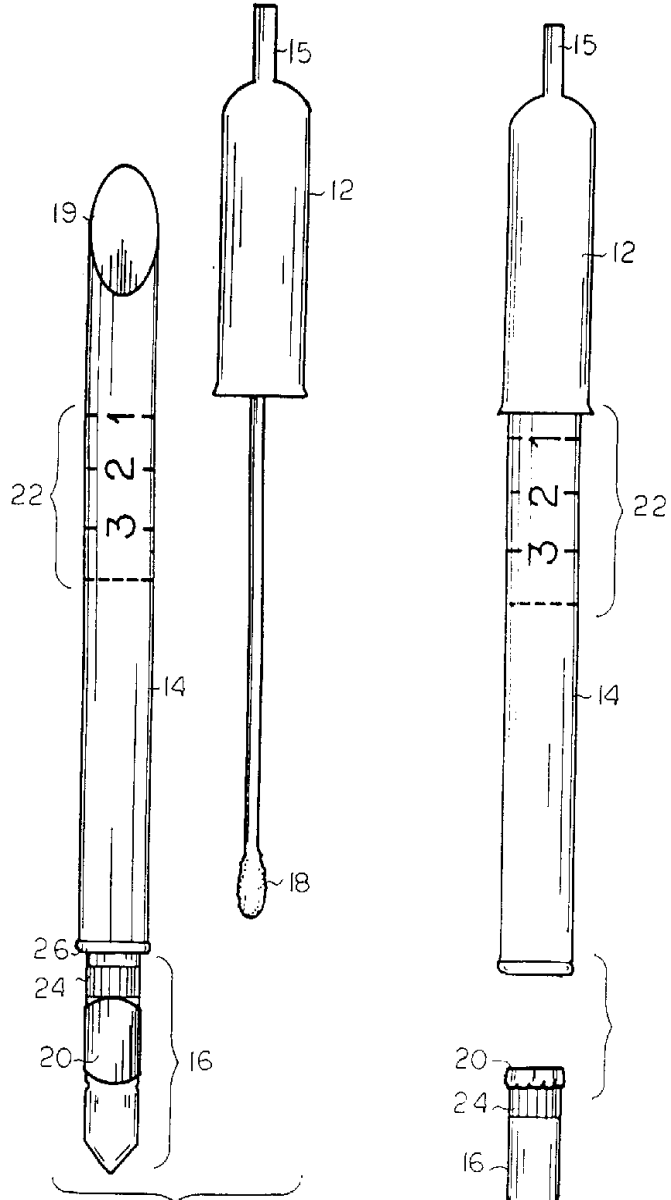

FIG. 3

FIG. 4

3/4

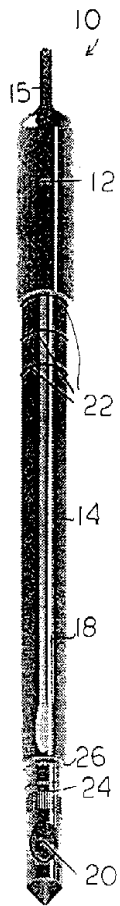

FIG. 5A

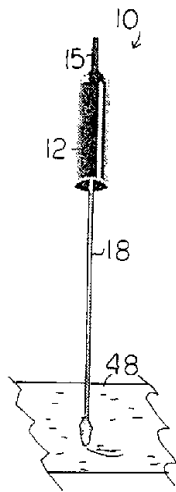

FIG. 5B

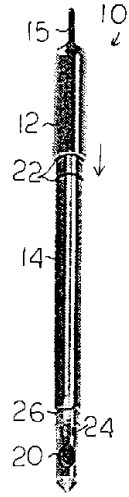

FIG. 5C

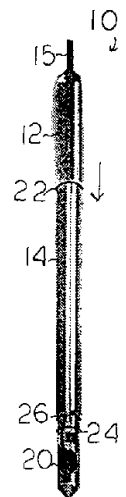

FIG. 5D

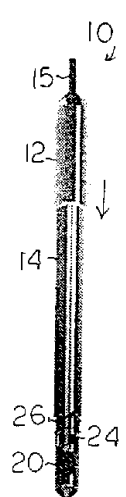

FIG. 5E

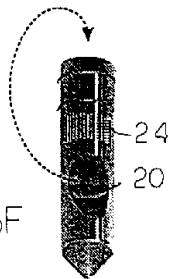

FIG. 5F

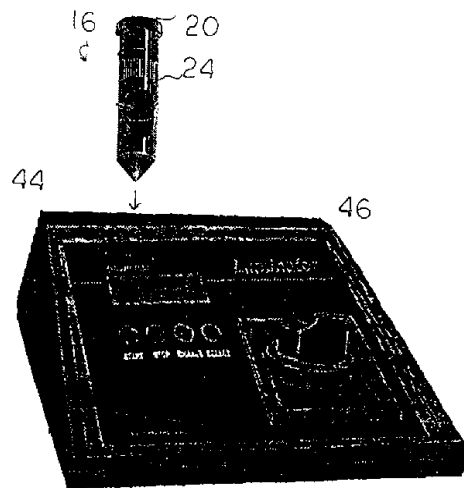

FIG. 5G

FIG. 5

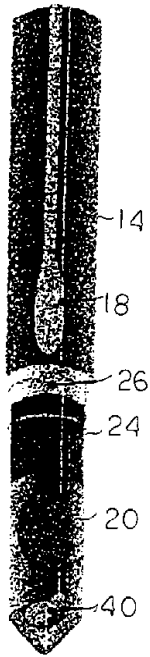

FIG. 6

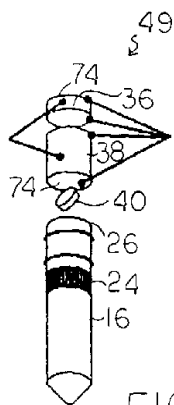

FIG. 7

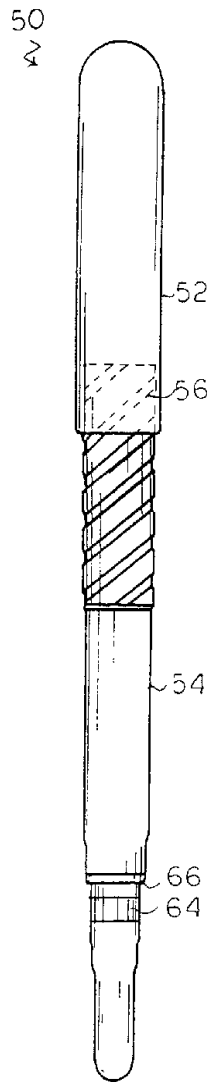

FIG. 8A

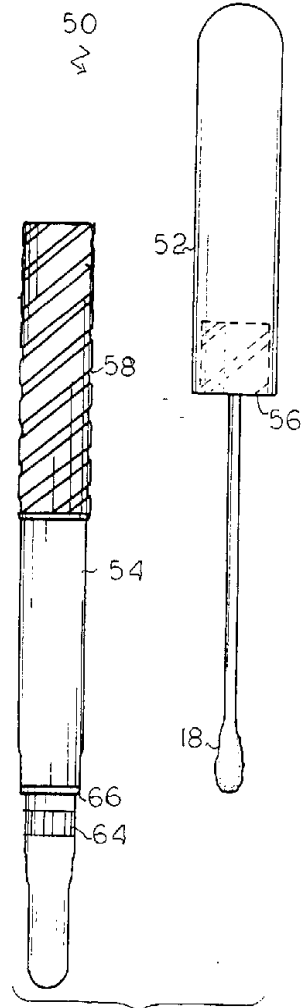

FIG. 8B

FIG. 8