

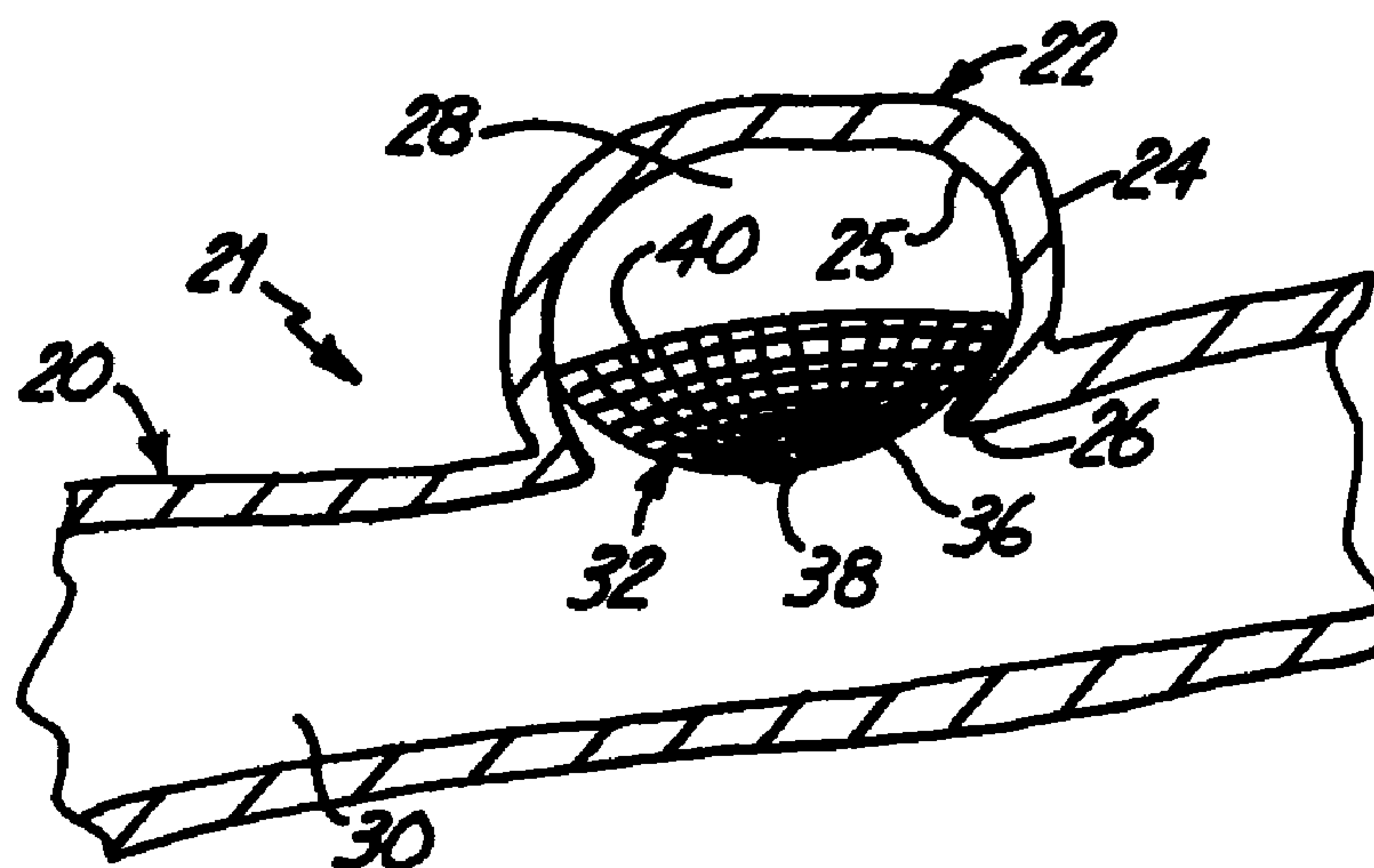

(72) MCCRORY, JENNIFER J., US
(72) GUTERMAN, LEE R., US
(72) TREMAGLIO, ANTHONY R., JR., US
(71) BOSTON SCIENTIFIC CORPORATION, US
(51) Int.Cl.⁷ A61B 17/12
(30) 1997/08/04 (60/054,810) US
(54) **SYSTEME D'OCCLUSION SERVANT A REPARER UN ANEURISME**
(54) **OCCLUSION SYSTEM FOR ANEURYSM REPAIR**



(57) Système interne d'occlusion permettant de traiter un collet anévrismal (22) dans une artère mère (20). Cette dernière définit une lumière (30). L'anévrisme (22) présente un collet (26) et une paroi intérieure définissant une cavité (28) communiquant avec la lumière (30). Le dispositif d'occlusion (32) est conçu pour se déployer à l'intérieur de la cavité (28). Ce dispositif (32) comprend un élément souple perméable à l'écoulement sanguin. Ce dispositif (32) est conçu de telle sorte que, quand il est déployé à l'intérieur de la cavité (28), l'élément relie le collet de l'anévrisme (22) et est en contact avec la paroi intérieure. Lorsqu'on traite l'anévrisme (22), ce dispositif (32) est replié et placé à l'intérieur du vaisseau à proximité de l'anévrisme (22). On dilate ensuite ce dispositif (32) à l'intérieur de la cavité, de manière à relier le collet (26) de l'anévrisme (22). On peut injecter un agent embolique (50) dans la cavité (28) après le déploiement du dispositif d'occlusion du collet.

(57) An internal neck occlusion system treats an aneurysm (22) in a parent vessel (20). The parent vessel (20) defines a lumen (30). The aneurysm (22) includes a neck (26) and an inner wall defining a cavity (28) communicating with the lumen (30). The occlusion device (32) is configured for deployment within the cavity (28). The device (32) includes a collapsible member which is permeable to blood flow. The device (32) is arranged such that, when deployed within the cavity (28), the member bridges the neck (26) of the aneurysm (22) and is in contact with the inner wall. In treating the aneurysm (22), the device (32) is collapsed and endovascularly placed proximate the aneurysm (22). The device (32) is then expanded within the cavity so as to bridge the neck (26) of the aneurysm (22). An embolic agent (50) can be injected into the cavity (28) after the neck occlusion device is deployed.



PCT

WORLD INTELLECTUAL PROPERTY ORGANIZATION
International Bureau

INTERNATIONAL APPLICATION PUBLISHED UNDER THE PATENT COOPERATION TREATY (PCT)

<p>(51) International Patent Classification ⁶ : A61B 17/12</p>	<p>A1</p>	<p>(11) International Publication Number: WO 99/05977</p> <p>(43) International Publication Date: 11 February 1999 (11.02.99)</p>
<p>(21) International Application Number: PCT/US98/15690</p> <p>(22) International Filing Date: 29 July 1998 (29.07.98)</p> <p>(30) Priority Data: 60/054,810 4 August 1997 (04.08.97) US</p> <p>(71) Applicant: BOSTON SCIENTIFIC CORPORATION [US/US]; One Boston Scientific Place, Natick, MA 01760-1532 (US).</p> <p>(72) Inventors: McCrory, Jennifer, J.; 15 River Street #404, Boston, MA 02108 (US). GUTERMAN, Lee, R.; 550 LeBrun Road, Amherst, NY 14226 (US). TREMAGLIO, Anthony, R., Jr.; Apartment 614, 1284 Beacon Street, Brookline, MA 02146 (US).</p> <p>(74) Agents: KELLY, Joseph, R. et al.; Westman, Champlin & Kelly, P.A., Suite 1600 - International Centre, 900 Second Avenue South, Minneapolis, MN 55402-3319 (US).</p>		<p>(81) Designated States: AL, AM, AT, AU, AZ, BA, BB, BG, BR, BY, CA, CH, CN, CU, CZ, DE, DK, EE, ES, FI, GB, GE, GH, GM, HU, ID, IL, IS, JP, KE, KG, KP, KR, KZ, LC, LK, LR, LS, LT, LU, LV, MD, MG, MK, MN, MW, MX, NO, NZ, PL, PT, RO, RU, SD, SE, SG, SI, SK, SL, TJ, TM, TR, TT, UA, UG, UZ, VN, YU, ZW, ARIPO patent (GH, GM, KE, LS, MW, SD, SZ, UG, ZW), Eurasian patent (AM, AZ, BY, KG, KZ, MD, RU, TJ, TM), European patent (AT, BE, CH, CY, DE, DK, ES, FI, FR, GB, GR, IE, IT, LU, MC, NL, PT, SE), OAPI patent (BF, BJ, CF, CG, CI, CM, GA, GN, GW, ML, MR, NE, SN, TD, TG).</p> <p>Published <i>With international search report.</i></p>
<p>(54) Title: OCCLUSION SYSTEM FOR ANEURYSM REPAIR</p>		
<p>(57) Abstract</p>		
<p>An internal neck occlusion system treats an aneurysm (22) in a parent vessel (20). The parent vessel (20) defines a lumen (30). The aneurysm (22) includes a neck (26) and an inner wall defining a cavity (28) communicating with the lumen (30). The occlusion device (32) is configured for deployment within the cavity (28). The device (32) includes a collapsible member which is permeable to blood flow. The device (32) is arranged such that, when deployed within the cavity (28), the member bridges the neck (26) of the aneurysm (22) and is in contact with the inner wall. In treating the aneurysm (22), the device (32) is collapsed and endovascularly placed proximate the aneurysm (22). The device (32) is then expanded within the cavity so as to bridge the neck (26) of the aneurysm (22). An embolic agent (50) can be injected into the cavity (28) after the neck occlusion device is deployed.</p>		

OCCLUSION SYSTEM FOR ANEURYSM REPAIR

BACKGROUND OF THE INVENTION

5 The present invention deals with a system for
treating an aneurysm. More specifically, the present
invention is directed to an occlusion system for
deployment of an occlusion device within the aneurysm.

10 An aneurysm is a localized stretching or
distension of an artery due to a weakening of the vessel
wall. For example, congenital "berry" aneurysms, i.e.,
small spherical distensions, occur in the vessels of the
brain. The distensions -- often referred to as the
aneurysm sac -- are related to defects in the muscular
coating of the artery and are probably developmental in
15 origin. Rupture of aneurysms account for the majority
of spontaneous hemorrhages. Approximately 25,000
intracranial aneurysms rupture every year in North
America.

20 Several methods of treating aneurysms have
been attempted, with varying degrees of success. At
present, the treatment of aneurysms with drugs is
substantially ineffective. Also, extra-vascular
surgery, referred to as open craniotomy, for the purpose
of preserving the parent artery is replete with
25 disadvantages. A patient subject to open craniotomy for
intercranial aneurysms typically must undergo general
anesthesia, surgical removal of part of the skull, brain
retraction, dissection around the neck of the sac, and
placement of a clip on the parent artery to prevent
30 rebleeding.

Alternative treatments include endovascular
occlusion where the interior of the aneurysm is entered
with a guidewire or a microcatheter. An occlusion is

-2-

formed within the sac with an intention to preserve the parent artery. A preferred means for forming a mass is through the introduction of an embolic agent within the sac. Examples of embolic agents include a detachable
5 coil, which is detached from the end of a guidewire, and a liquid polymer which polymerizes rapidly on contact with blood to form a firm mass. The embolic agent may initially generate a thrombotic mass in the sac as well. The thrombotic mass is composed of the elements of
10 blood, namely platelets, fibrin, red cells and leukocytes. However, the thrombotic mass may typically dissipate through the normal lysing process.

Endovascular occlusion is not without drawbacks. For example, there is a risk of overfilling
15 the sac and consequent embolic agent migration into the parent vessel. This results in occlusion of the parent artery and could lead to distal embolization. Further, there is a risk of the embolic agent becoming dislodged from hemodynamic forces, which can result in distal
20 embolization, restricted blood flow in the parent artery or total occlusion of the parent artery.

Moreover, endovascular occlusion can be ineffective when the neck of an aneurysm is not well defined because the risk of embolic agent migration is
25 greater with such a sac. Prior art methods used to reduce the risk of embolic agent migration in an ill-defined neck include blockage of the parent artery with a device inside the vasculature to isolate the sac from circulation while the occlusion is formed. However,
30 blockage of the parent artery can itself be highly undesirable, but necessary in certain circumstances when the aneurysm presents a greater risk to the patient. After the occlusion is formed in the cavity, and circulation is restored in the parent artery, an ill-

-3-

defined neck increases the risk of the embolic agent becoming dislodged.

SUMMARY OF THE INVENTION

An internal neck occlusion system is used for
5 treating an aneurysm in a parent vessel. The parent
vessel defines a lumen. The aneurysm includes a neck
and an inner wall defining a cavity communicating with
the lumen. The occlusion device is configured for
10 deployment within the cavity. The device includes a
collapsible member which is permeable to blood flow.
The device is arranged such that, when deployed within
the cavity, the member bridges the neck of the aneurysm
and is in contact with the inner wall.

In treating the aneurysm, the internal neck
15 occlusion device is collapsed and endovascularly placed
proximate the aneurysm. The device is then expanded
within the cavity so as to bridge the neck of the
aneurysm. An embolic agent can be injected into the
cavity after the neck occlusion is deployed.

BRIEF DESCRIPTION OF THE DRAWINGS

20 FIG. 1 is a side view of an occlusion device
deployed within an aneurysm.

FIGS. 2A-2D show the deployment of the
occlusion device of FIG. 1 within the aneurysm.

25 FIGS. 3A-3C show the deployment of an embolic
agent in cooperation with the device of FIG. 1 within
the aneurysm.

FIG. 4 is a side view of another occlusion
device deployed within an aneurysm.

30 FIGS. 5A-5C show the deployment of the
occlusion device of FIG. 4.

FIG. 6 shows the occlusion device of FIG. 4 in
cooperation with an embolic agent within the aneurysm.

-4-

FIG. 7 is a side view of another occlusion device deployed within an aneurysm.

FIG. 8 shows the deployment of the device of FIG. 7.

5 FIG. 9 is a side view of another occlusion device deployed within an aneurysm.

FIG. 10 is a top view of the device of FIG. 9.

FIGS. 11A-11D illustrate the deployment of the device of FIG. 9.

10 DETAILED DESCRIPTION OF THE PREFERRED EMBODIMENTS

FIG. 1 shows parent vessel 20 sectioned for clarity within a vascular region 21 of the body. The vessel 20 has an aneurysm 22 with a sac 24, inner wall 25 and neck 26. The sac 24 forms a vascular cavity 28 in communication with the lumen 30 of vessel 20. Occlusion device 32, in accordance with the present invention, is deployed in the vascular cavity 28 proximate the neck 26.

20 The device 32 is preferably a flexible structure capable of bridging the neck 26 from within the aneurysm 22. In the illustrated embodiment, device 32 does not interfere with the lumen 30 of parent vessel 20. The device 32 is formed in the shape of a dish, and includes a plurality of struts 36 which project radially from the center 38. The device 32 also includes a plurality of parabolic rings 40 which lend stability to the structure. The struts 36 may be formed of any suitable material, but in the preferred embodiment are formed from metal and covered with fabric. Rather than 25 rings of fabric, the struts may be covered with a mesh, not shown. Alternatively, the device 32 may be formed of a polymeric or similar material.

30 Device 32 can be deployed in the aneurysm 22 in a variety of ways. FIGS. 2A-2D show the deployment

-5-

of device 32 in accordance with the present invention. FIG. 2A shows device 32 collapsed and attached to the distal end 42 of delivery catheter 44 inside lumen 30. Device 32 is a shape memory structure which is capable of residing in a collapsed state but then expands to its dish-like state in response to an appropriate stimulus. The device 32 can be made of thermo-sensitive material which is flexible below a transition temperature and readily collapsible, but which is less resilient or generally rigid above the transition temperature. In the preferred embodiment, the struts 36 may be formed of small diameter nitinol wire which has the shape memory properties described above.

As indicated in FIG. 2A, the device 32 is collapsed and delivered through the vasculature 21 in a more flexible state, below its transition temperature. FIG. 2B shows the collapsed device 32 within the aneurysm 22 and positioned there with the delivery catheter 44. The delivery catheter 44 can be used to manipulate and adjust the position of device 32 within the aneurysm 22 before and/or after it is expanded.

Once in place within the aneurysm 22, the temperature of the vascular region is raised from a point below the transition temperature to a point above the transition temperature. This can be accomplished, for instance, by injecting warm saline or the like into the vascular region, or simply by letting the occlusion device 32 warm to body temperature. Also, device 32 can be delivered while being flushed with a cold saline solution to maintain the temperature of device 32 below its transition temperature. Once device 32 is in place, the cold saline flush is discontinued and device 32 warms to a temperature above the transition temperature. After the occlusion device 32 reaches the transition

-6-

temperature, it expands to the predetermined diameter or width and makes contact with the inner walls 25 and the neck 26.

FIG. 2C shows the device 32 expanded to bridge neck 26 of the aneurysm 22. The delivery catheter 44 is then detached from the device 32 which remains in place within the aneurysm 22. Detachment can be accomplished in any number of suitable ways. For instance, device 32 can be attached with a soluble adhesive and detached by injecting a suitable solvent. Also, device 32 can be attached by a frictional fit and detached by exerting a force on catheter 44. Further, device 32 can be detached electrolytically in the same fashion as a Guglielmi detachable coil (GDC). FIG. 2D shows device 32 permanently in position within the aneurysm 22 with the delivery catheter 44 removed.

Device 32 can also be formed of a resilient material which is permanently biased in the deployed position. In order to collapse device 32 for introduction into the vasculature, a filament or other fibrous thread can be removably wound about the exterior of device 32 maintaining it in a collapsed position. Once device 32 is introduced into cavity 28, the thread is removed, allowing device 32 to deploy outwardly. Removal of the thread is preferably accomplished by exerting gentle traction on the thread which causes it to disengage from device 32.

FIGS. 3A-3C show the delivery of an embolic agent 50 through the device to form a thrombotic mass within the aneurysm 22. FIG. 3A shows a microcatheter 52 having the embolic agent 50 at the distal tip 54 of the catheter 52. The embolic agent 50, such as a stainless steel coil or a liquid polymer, or a combination of solid and liquid embolic agents (e.g., a

-7-

coil and a liquid polymer) is delivered to the aneurysm via the microcatheter. FIG. 3B shows the injection of the embolic agent 50 within the aneurysm 22. Distal tip 54 is positioned against the device 32 such that the embolic agent 50 extends into the cavity 28. Distal tip 54 and device 32 preferably include markings thereon such that they can be viewed during the procedure using conventional fluoroscopy, x-ray or ultrasound, or other suitable techniques, or device 32 and distal tip 54 are viewed with the aid of a suitable scope or fiber optic bundle.

The permeable nature of the device 32 allows the distal tip of delivery catheter 52 to be positioned behind device 32 in cavity 28. The delivery catheter 52 is movable relative to device 32 to allow precise placement of the distal tip of the catheter within the cavity 28. Catheter tip placement influences the quality of filling, and the adjustable nature improves the ability to fill the aneurysm 22. As the embolic agent 50 is injected into the cavity 28, the blood within the aneurysm 22 escapes through the neck 26 and through the holes in device 32. As the embolic agent 50 fills cavity 28, it acts to further secure the device 32 in place in the neck 26. It is to be understood that the embolic agent 50 may be deployed either prior to detachment of the delivery catheter 44 or after detachment.

FIG. 3C shows the embolic agent 50 packed within the aneurysm 22, held in place with the occlusion device 32, and with the delivery catheter 52 removed. The device 32 and embolic agent 50 cooperate to repair the aneurysm. The embolic agent 50 secures the device 32 within the sac 24 in the region of neck 26 and prevents the device 32 from being pushed further into

-8-

the sac 24 by hemodynamic forces. The device 32 traps the embolic agent 50, permits a tighter packing of the embolic agent 50, and reduces the likelihood of migration of the embolic agent 50 out of aneurysm 22 into parent vessel 20. This helps prevent distal embolization.

Also, the presence of the device 32 at the neck 26 provides a scaffolding for tissue to grow and create a new endoluminal surface inside the vessel 20 to isolate the aneurysm 22 from the circulation of blood within the vasculature 21. The device 32 may be combined with biologic materials such as collagen, fibrin, or the like, to facilitate both thrombosis and cell infiltration and fibrotic tissue growth over the neck 26 to create the new parent artery endoluminal surface.

It should be noted that device 32 is preferably formed of a continuous structure as shown in FIGS. 1-3C. However, it can also be formed of several leaflet members connected by a hinge connection at a center portion of device 32 and configured to fold out upon deployment within aneurysm 22.

FIG. 4 shows an illustration of another occlusion device 62 in accordance with the present invention (generally referred to as a spherical occlusion device) where like portions of the vasculature 21 are referred to by like reference numerals. Spherical occlusion device 62 is similar to device 32 shown in FIG. 1 in that it is to be deployed within the aneurysm 22 and is generally permeable to blood flow. However, the spherical device 62 includes a collapsible spherical mesh structure 64 that not only covers the neck 26 of aneurysm 22 but provides stability to the entire inner wall 25 of the aneurysm 22. The structure

-9-

64 can be fashioned from the same materials used to make device 32, as described above.

FIGS. 5A-5C show the deployment of the spherical device 62 in accordance with the present invention. FIG. 5A shows the collapsed device 62 inserted within the distal tip 66 of a delivery catheter 68 rather than attached thereto. FIG. 5B shows the placement of the distal tip 66 within the aneurysm 22. The device 62 is then advanced out of catheter 68 and into the aneurysm 22 and allowed to expand and bridge the neck 26 of the aneurysm 22. FIG. 5C shows the expanded spherical device 62 within the aneurysm 22 with the catheter 68 removed. It is to be understood that this deployment method is suitable for other occlusion devices in accordance with the present invention and not limited to the spherical device.

After the device 62 is expanded within the aneurysm 22, a microcatheter can be used in the fashion described above to deliver an embolic agent within the spherical device. Alternatively, the same catheter used to deliver spherical device 62 can be used to deliver the embolic agent. FIG. 6 shows the embolic agent 69 packed within the spherical device 62. The spherical device 62 provides support for the entire aneurysm wall during the delivery of the embolic agent 69 and thereafter. This allows tighter packing of the embolic agent 69 with a reduced likelihood of overflow, and reduced likelihood of rupture particularly at the typically fragile dome region 70 of the aneurysm 22.

FIG. 7 shows another occlusion device 72 constructed in accordance with the present invention. The device 72 includes a distal portion 74 which can be similar to the dish-like device 32 shown in FIG. 1 or in the shape of a sphere (not shown). The distal portion

-10-

74 preferably includes a nitinol wire frame 76 and covered with a mesh 78, or the like. The distal portion 74 is deployed within the aneurysm 22 and is preferably secured against the inner wall 25 of the aneurysm 22 at the neck 26. A proximal portion 80 includes a frame 82 attached to the frame 76 of the distal portion 74. The frame 82 can be covered with a mesh 84. Preferably, the proximal portion 80 is expandable to conform to the inner wall of the parent vessel 20. In one preferred embodiment, the distal portion 74 is coated or treated with thrombogenic agents in a manner known to those skilled in the art to facilitate thrombosis within the aneurysm 22. The proximal portion 80, on the other hand, can be coated with non-thrombogenic agents which reduce the likelihood of thrombosis within the parent vessel 20. Once seated in the neck 26 of aneurysm 22, the distal portion 74 inhibits the migration of the device 72 into the parent vessel 20. The proximal portion 80 inhibits the migration of the device 72 into the aneurysm sac 24.

FIG. 8 shows the preferred means of deployment of the device 72. The proximal portion 80 is collapsed and inserted into the distal tip 86 of a delivery catheter 88. The distal portion 74 may also be inserted within the delivery catheter 88 or can extend past the distal tip 86. During deployment, the distal portion 74 is positioned with the catheter 88 to be within the aneurysm 22, and is then permitted to expand (by advancing it out of the end of catheter 88, or by application of some other suitable stimulus). Distal portion 74 is preferably configured so that it can be deployed from within catheter 88, retracted back into catheter 88 and redeployed. The proximal portion 80 is then advanced out of, and detached from, the delivery

-11-

catheter 88. Again, this detachment can be accomplished by any suitable system such as electrolytic detachment from a delivery member or catheter in the same fashion as a GDC coil. Delivery catheter 88 is then removed
5 from the vascular region 21 to allow the proximal portion 80 to expand and conform to the shape of the inner wall 25 of the parent vessel 20.

FIG. 9 shows a view of another occlusion device 92 constructed in accordance with the present
10 invention and deployed within the aneurysm 22. Device 92 is formed in the shape of a parabolic dish and is characterized by a plurality of struts 94, or frame, and is covered by a mesh 96 similar to that of the device 32 shown in FIG. 1. However, the device 92 includes a
15 small valve 98, such as a mitral valve, attached to the frame 94 at the center 100 of the dish.

FIG. 10 shows a top view of the device 92 of FIG. 9. Nitinol struts 94 extend from the mitral valve 98 to form a generally circular shape. Preferably, the
20 mesh 96 does not cover the mitral valve 98.

FIGS. 11A-11D show the deployment of the device 92 in accordance with the present invention. FIG. 11A shows the collapsed device 92 attached to the distal tip 102 of a catheter 104. The distal tip 102 of
25 the catheter 104 is inserted through the mitral valve 98. An embolic agent 106 is contained within the catheter 104 for injection therethrough. FIG. 11B shows the collapsed device 92 positioned within the aneurysm 22. Once within the aneurysm 22, the device 92 is allowed to
30 expand. FIG. 11C shows the expanded device 92 in position within the aneurysm 22. Once the device 92 is expanded to bridge the neck 26 of the aneurysm 22, the embolic agent 106 is injected into the aneurysm 22 through the mitral valve 98. FIG. 11D shows the device 92

-12-

and embolic agent 106 within the aneurysm 22 with the catheter 104 removed. After the embolic agent 106 is deployed, gentle traction of the catheter 104 disengages the distal tip 102 from the mitervalve 98 which allows
5 removal of catheter 104. As with the other embodiments, other suitable detachment techniques can be used including electrolytic detachment.

It should be noted that the devices described herein can be coated with a number of suitable coatings.
10 Among the coatings which could be applied are growth factors. A number of suitable growth factors include vascular endothelial growth factor (VEGF), platelet derived growth factor (PDGF), vascular permeability growth factor (VPF), basic fibroblast growth factor
15 (bFGF), and transforming growth factor beta (TGF-beta).

Although the present invention has been described with reference to preferred embodiments, workers skilled in the art will recognize that changes may be made in form and detail without departing from
20 the spirit and scope of the invention.

WHAT IS CLAIMED IS:

1. A device for treating an aneurysm in a parent vessel, the parent vessel defining a lumen, the aneurysm having a neck and an inner wall defining a cavity communicating with the lumen, the device configured for deployment within the cavity, and comprising:
a collapsible member arranged such that, when the device is deployed, the member bridges the neck of the aneurysm and is in contact with the inner wall.
2. The device of claim 1 wherein the collapsible member is permeable to blood flow.
3. The device of claim 1 wherein the member comprises an expandable frame having a covering attached thereto.
4. The device of claim 3 wherein the frame includes a plurality of generally parabolic wire struts configured in the shape of a dish.
5. The device of claim 3 wherein the frame includes a plurality of struts configured in the shape of a sphere.
6. The device of claim 3 wherein the member further comprises a valve attached to the frame.
7. The device of claim 3 wherein the member further comprises a proximal portion having a proximal expandable frame attached to the expandable frame, the proximal expandable frame configured for deployment within the lumen.
8. The device of claim 7 wherein the distal expandable frame includes a plurality of parabolic struts configured in the shape of a dish.
9. The device of claim 8 wherein the proximal expandable frame is expandable to contact the parent vessel.

-14-

10. The device of claim 9 wherein the proximal expandable frame is coated with a non-thrombogenic agent.

11. The device of claim 1 wherein the member comprises an expandable wire frame covered by a permeable mesh.

12. The device of claim 11 wherein the expandable wire frame is made from a shape-memory material.

13. The device of claim 1 wherein the member is coated with a thrombogenic agent.

14. The device of claim 1 wherein the collapsible member has a covering layer thereon formed of a vascular growth factor.

15. A method of treating an aneurysm in a parent vessel having a lumen, the aneurysm having a neck and an inner wall defining a cavity communicating with the lumen, the method comprising:

endovascularly moving a treatment device to a site proximate the aneurysm; and
deploying the treatment device within the cavity so as to bridge the neck of the aneurysm with a portion of the treatment device.

16. The method of claim 15 wherein the treatment device includes a permeable portion thereof that is permeable to blood flow and wherein deploying comprises:

bridging the neck of the aneurysm with the permeable portion of the treatment device.

17. The method of claim 15 wherein the step of endovascularly moving a treatment device includes attaching the device to a catheter.

18. The method of claim 17 wherein the catheter includes a distal tip and wherein attaching the device

-15-

to a catheter comprises inserting the device at least partially within the distal tip.

19. The method of claim 17 wherein the catheter includes a distal tip, the device further includes a valve, and wherein attaching the device to a catheter includes inserting the distal tip within the valve.

20. The method of claim 19 and further comprising the step of applying traction to the catheter to detach the device from the catheter.

21. The method of claim 15 wherein deploying comprises:

advancing the treatment device to the cavity with a delivery system; and
detaching the treatment device from the delivery system.

22. The method of claim 21 wherein the delivery system includes an elongate delivery member connected to the treatment device, and wherein detaching comprises:
electrolytically detaching the treatment device from the delivery member.

23. The method of claim 20 wherein deploying further includes the step of injecting an embolic agent through the valve prior to detaching the device.

24. The method of claim 15 wherein the step of deploying the treatment device includes placing the device within the aneurysm; and expanding the device so as to contact the inner wall.

25. The method of claim 24 wherein the step of expanding the device includes raising the temperature within the cavity.

26. The method of claim 15 and further comprising the steps of:

-16-

endovascularly reaching the treatment device
with a microcatheter having an embolic
agent; and

injecting the embolic agent into the cavity.

27. The method of claim 26 wherein the embolic agent is one of a detachable coil and a liquid polymer.

28. The method of claim 26 wherein the embolic agent comprises:

a detachable coil and a liquid polymer.

29. The method of claim 26 wherein the catheter is removed from the site prior to the step of reaching the treatment device with a microcatheter.

30. The method of claim 26 wherein the treatment device is in the shape of one of a dish and a sphere.

31. The method of claim 15 wherein the treatment device includes a proximal expandable portion and a distal expandable portion, and wherein deploying comprises:

expanding the distal expandable portion
within the cavity; and

expanding the proximal expandable portion
within the lumen.

32. A system for treating an aneurysm in a vessel, the aneurysm having an inner wall and a neck defining a cavity, the system comprising:

a collapsible member attached to a delivery catheter;

wherein the collapsible member is configured to be endovascularly delivered to the aneurysm for deployment therein;

wherein the collapsible member is expanded within the cavity so as to bridge the neck and contact the inner wall; and

WO 99/05977

PCT/US98/15690

-17-

wherein the system includes a microcatheter configured to have an embolic agent is injected therethrough into the cavity to form a mass.

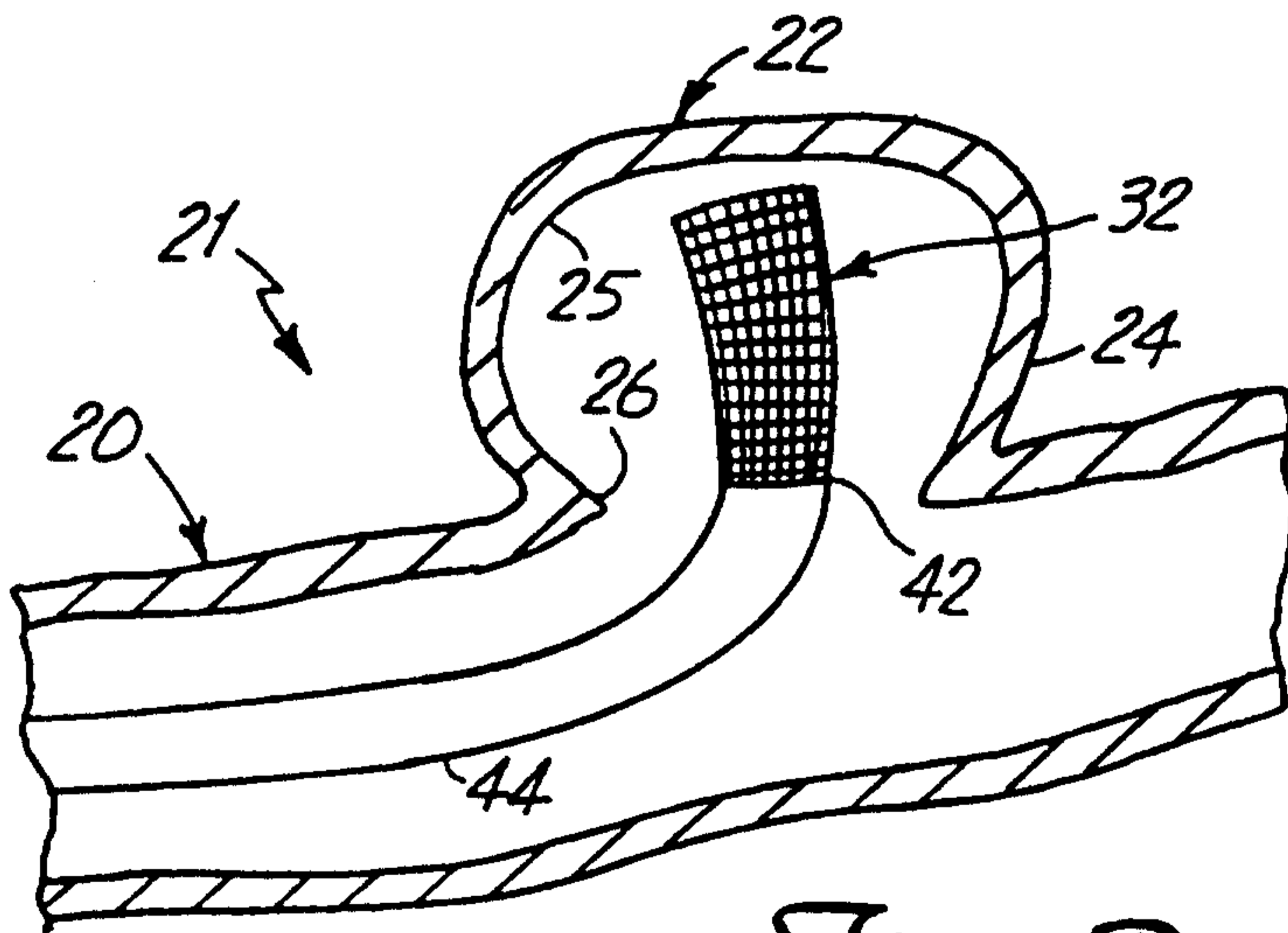
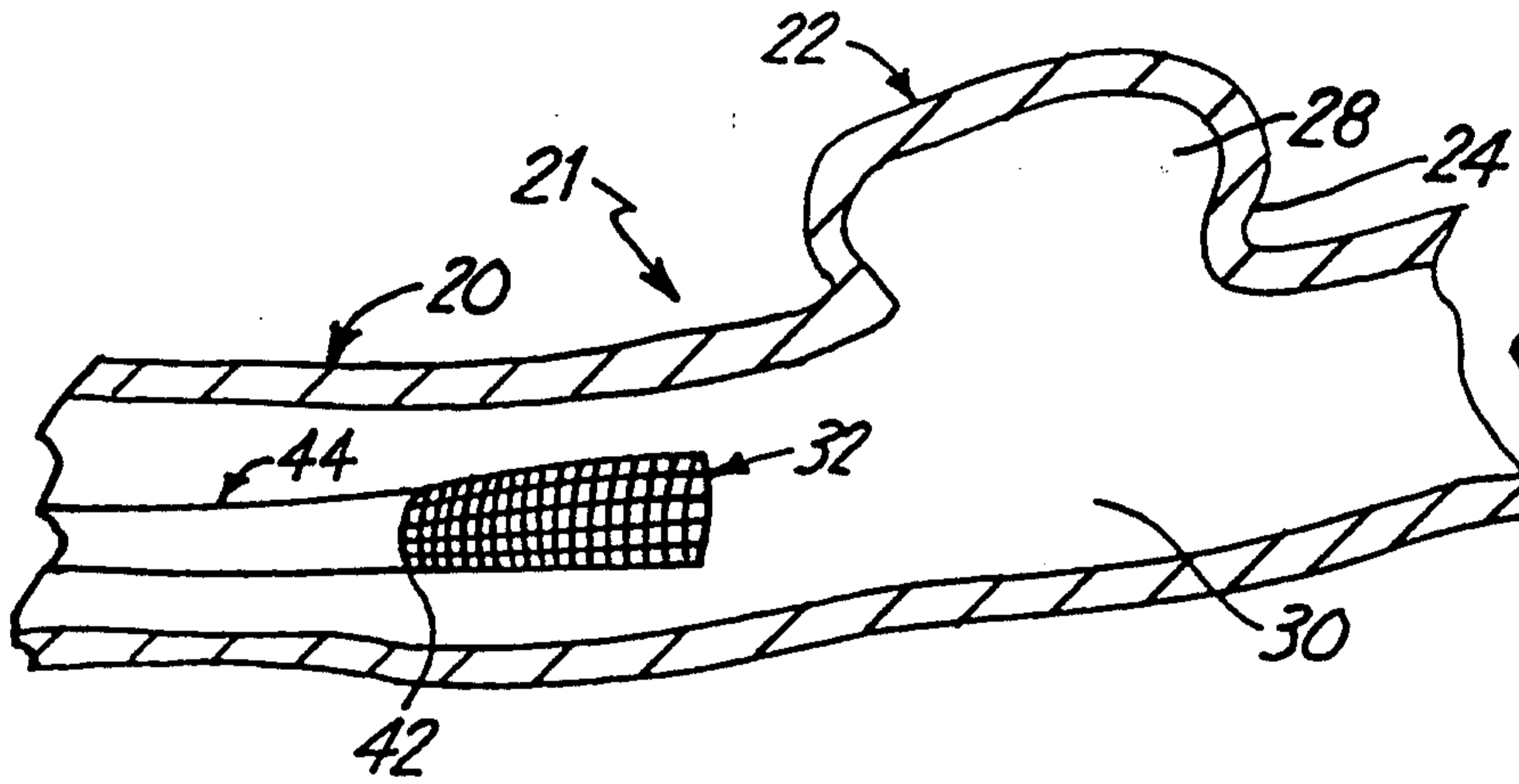
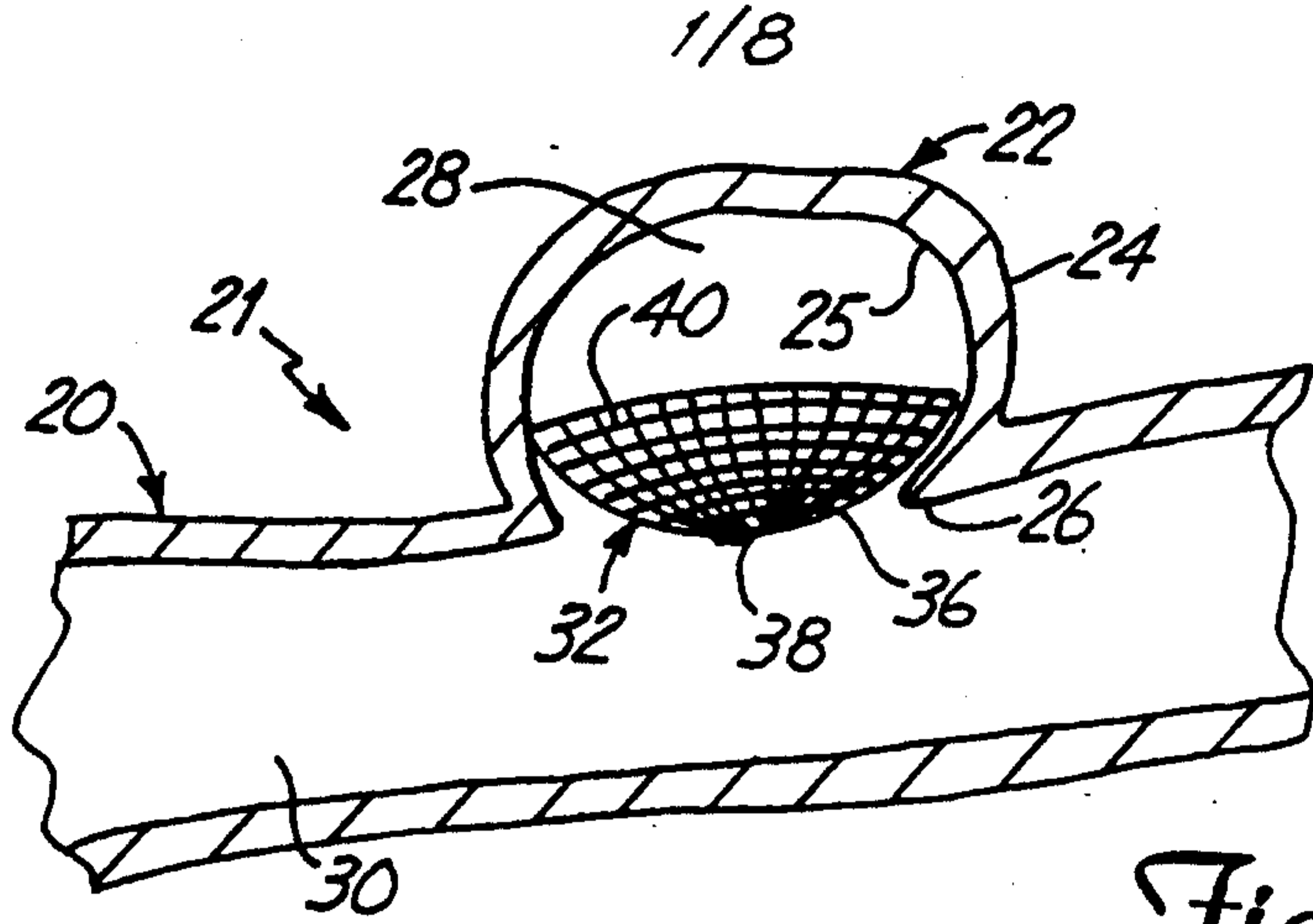

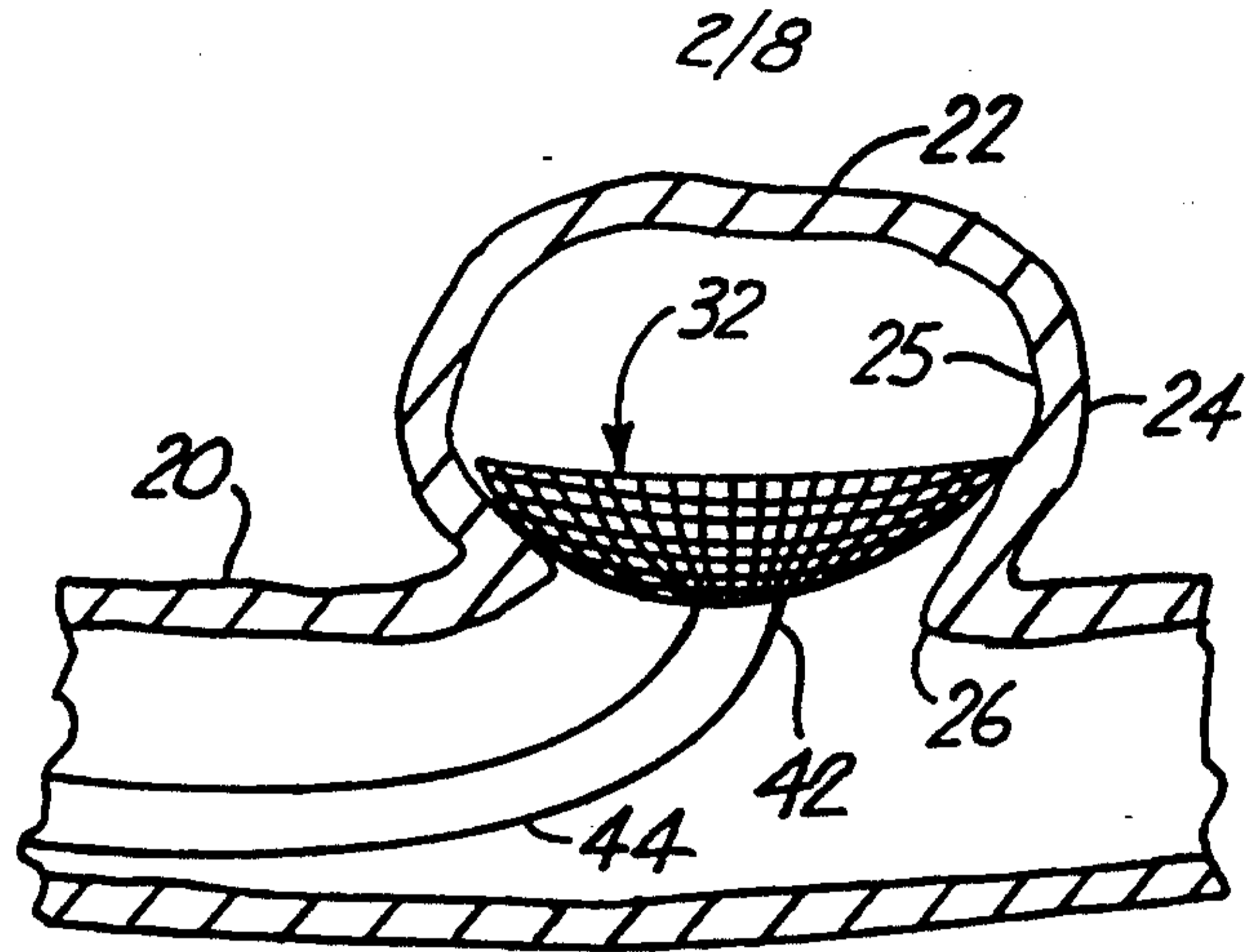

Fig. 2C

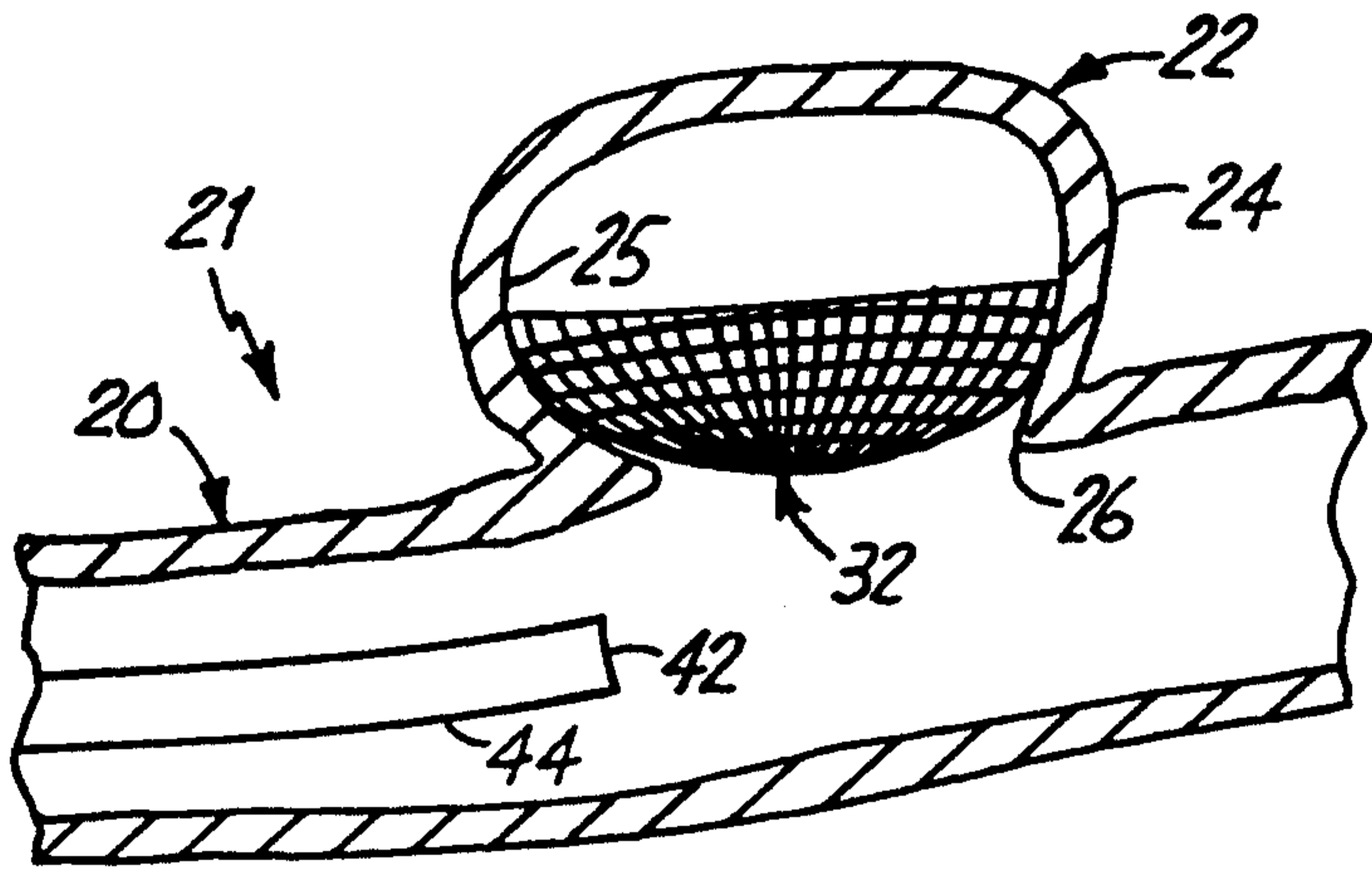

Fig. 2D

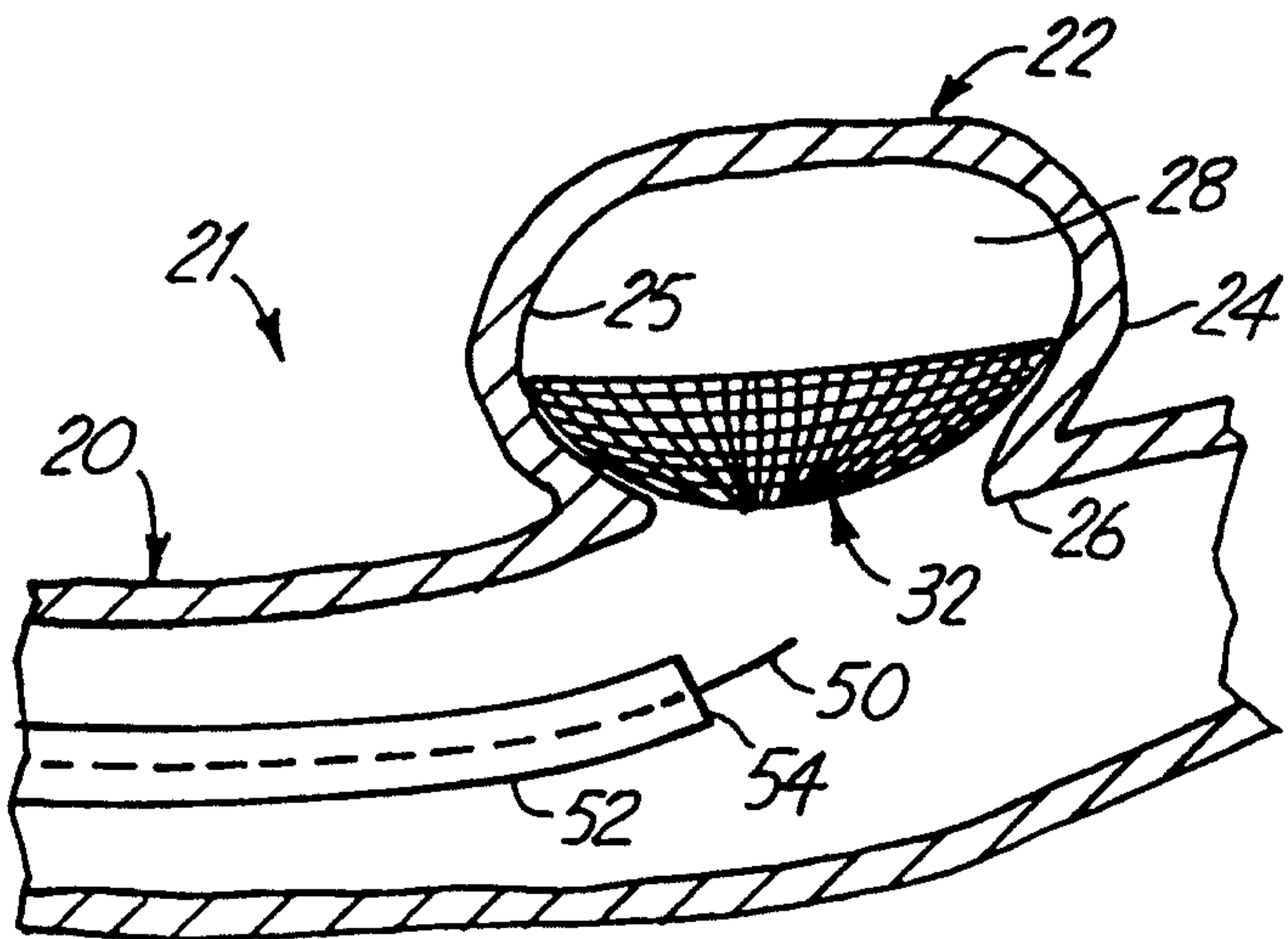

Fig. 3A

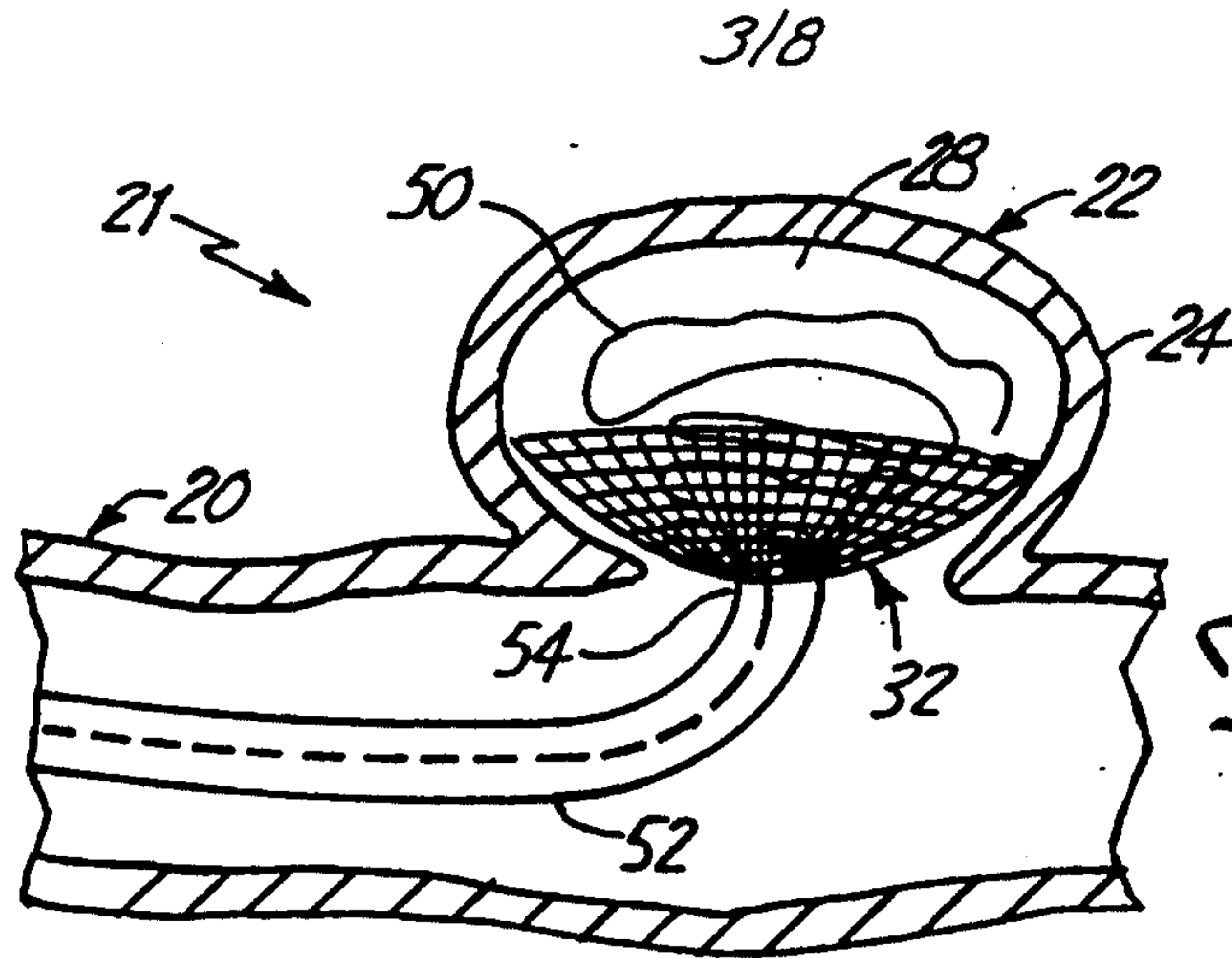

Fig. 3B

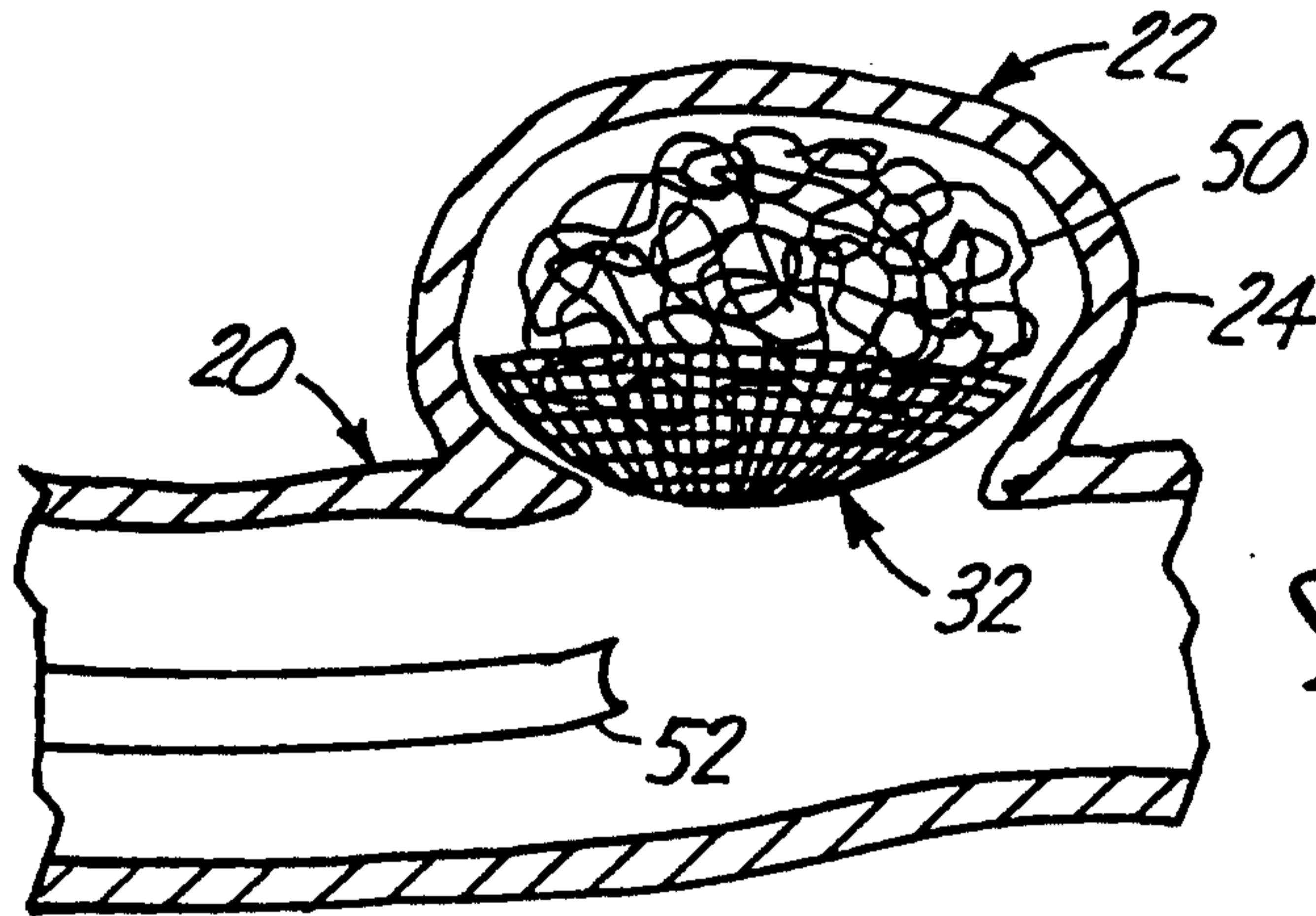

Fig. 3C

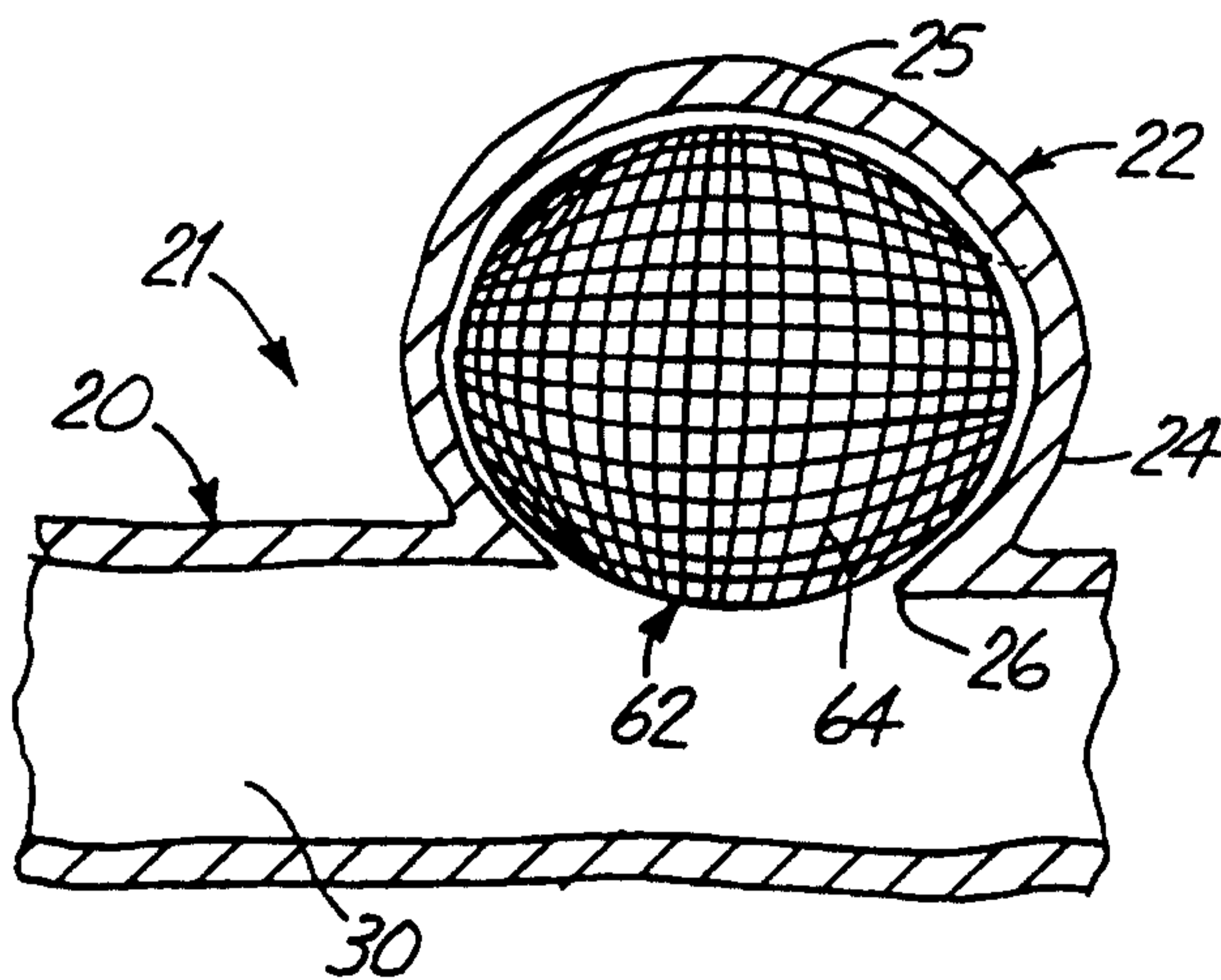

Fig. 4

4/8

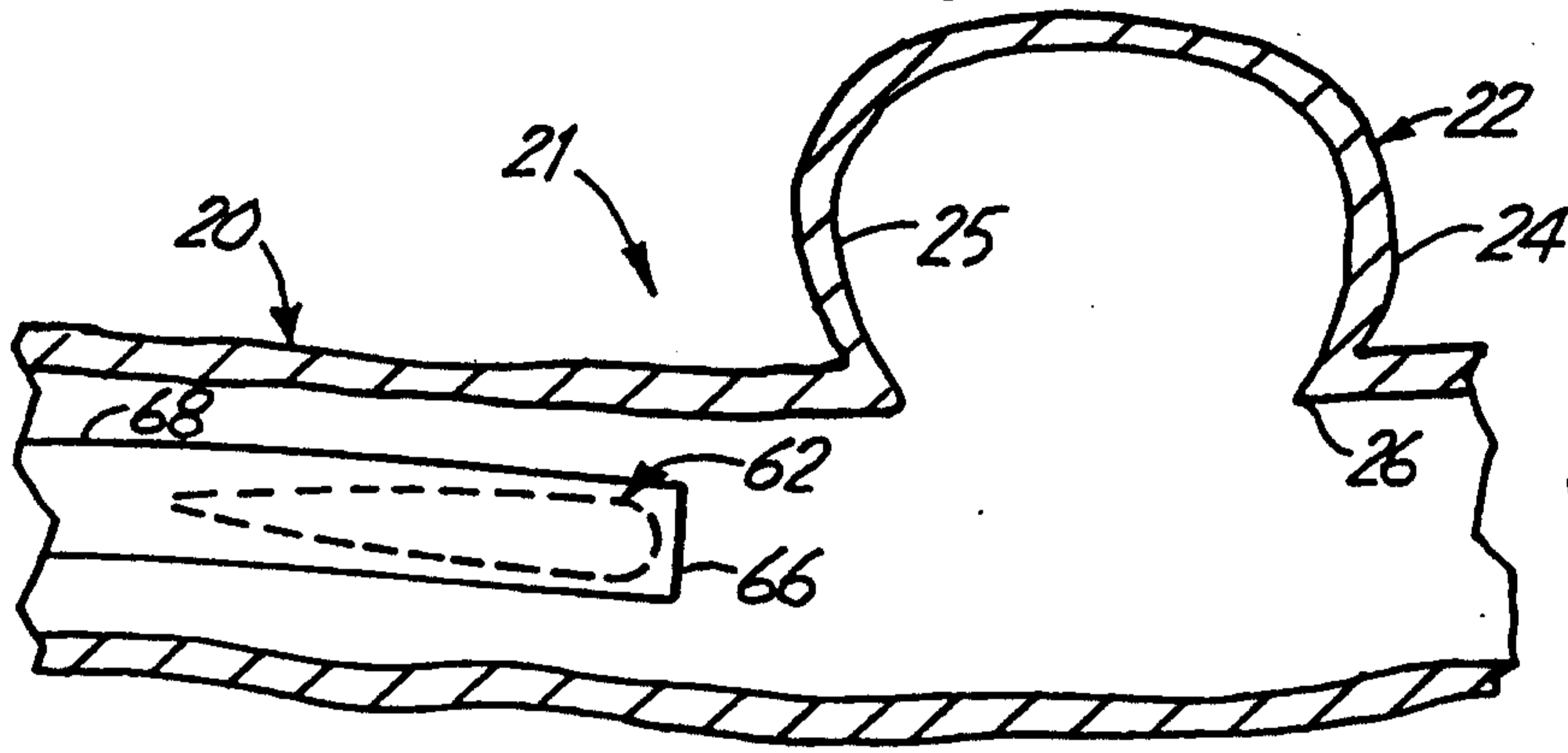

Fig. 5A

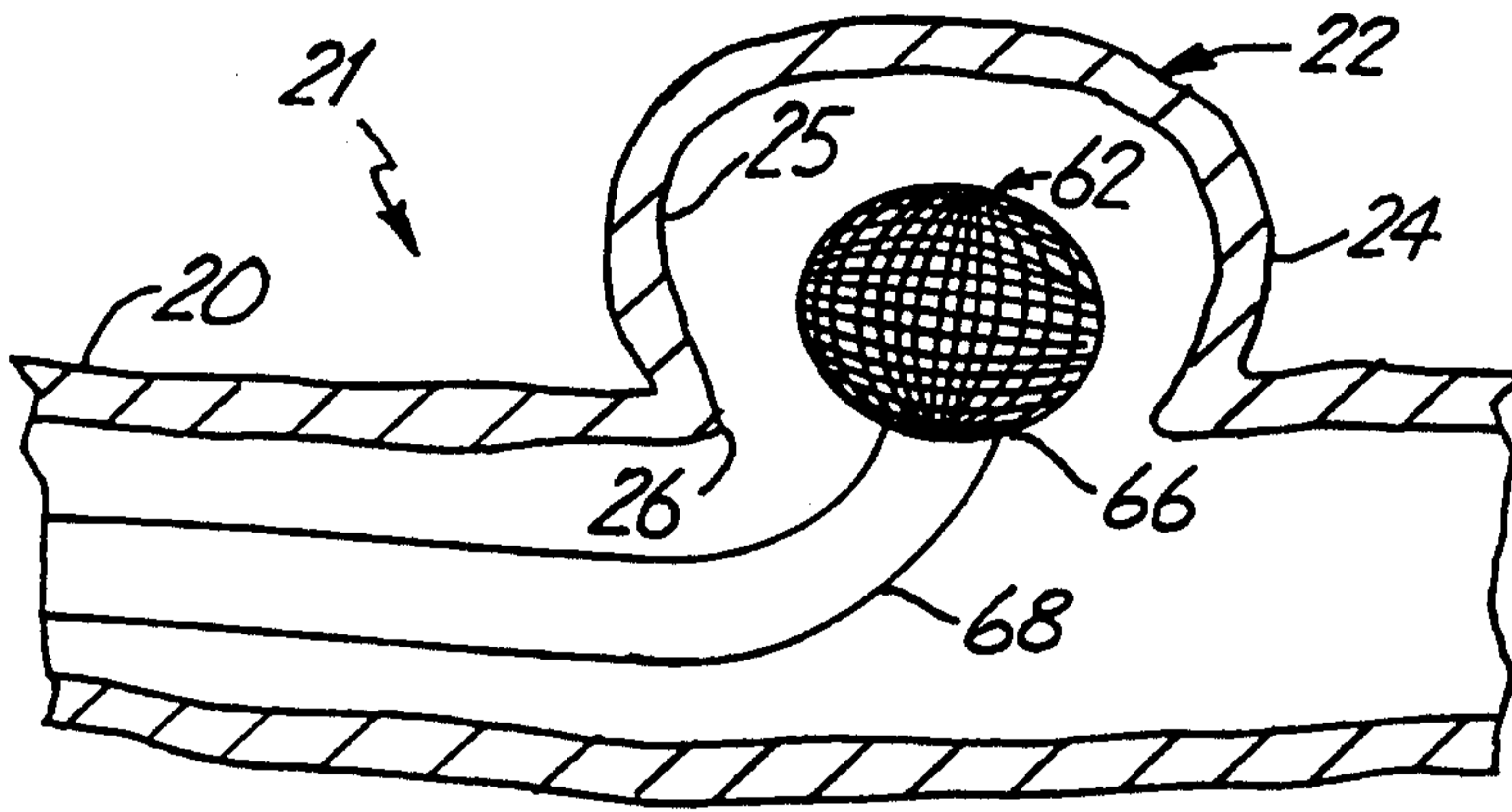

Fig. 5B

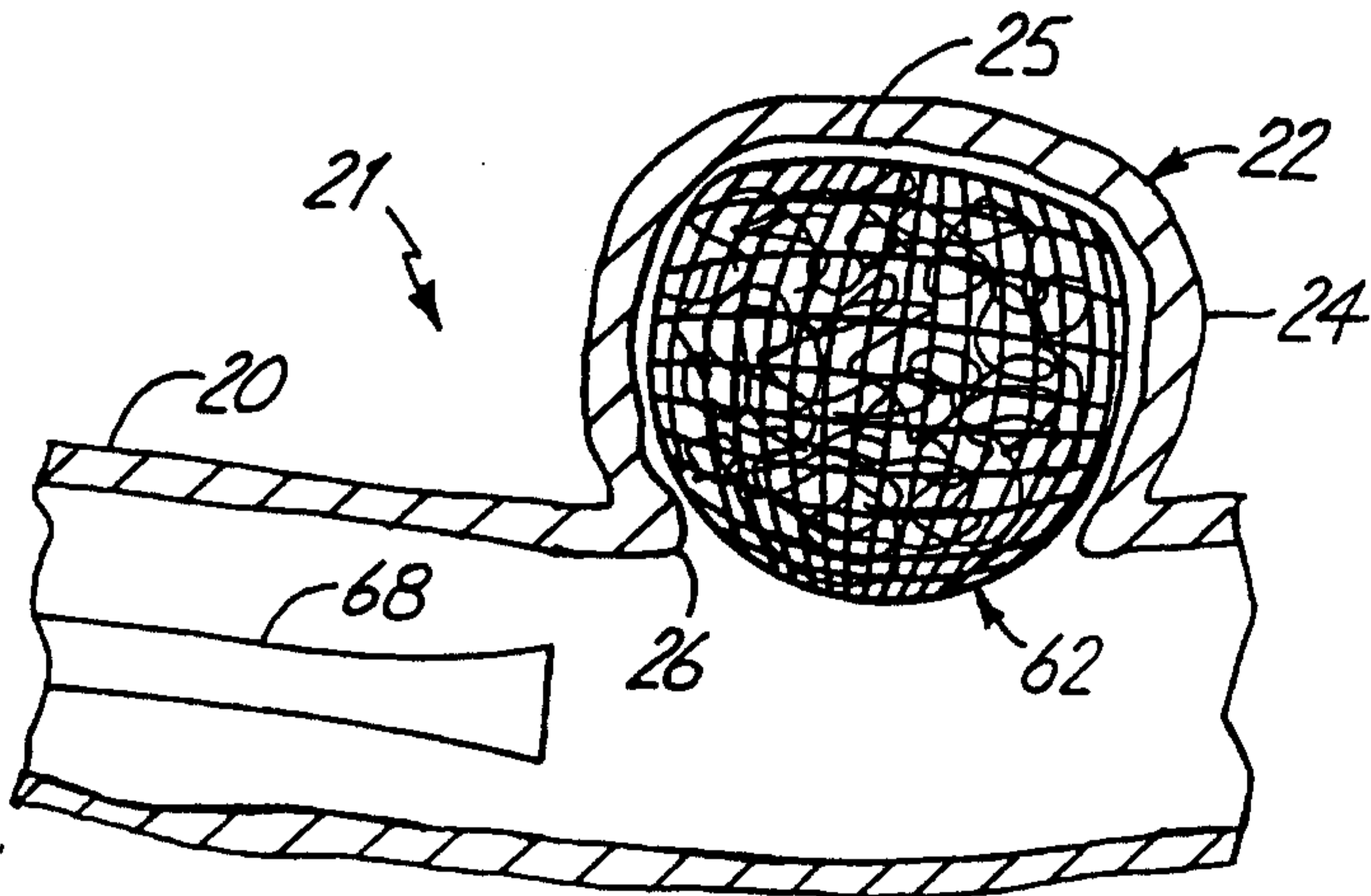

Fig. 5C

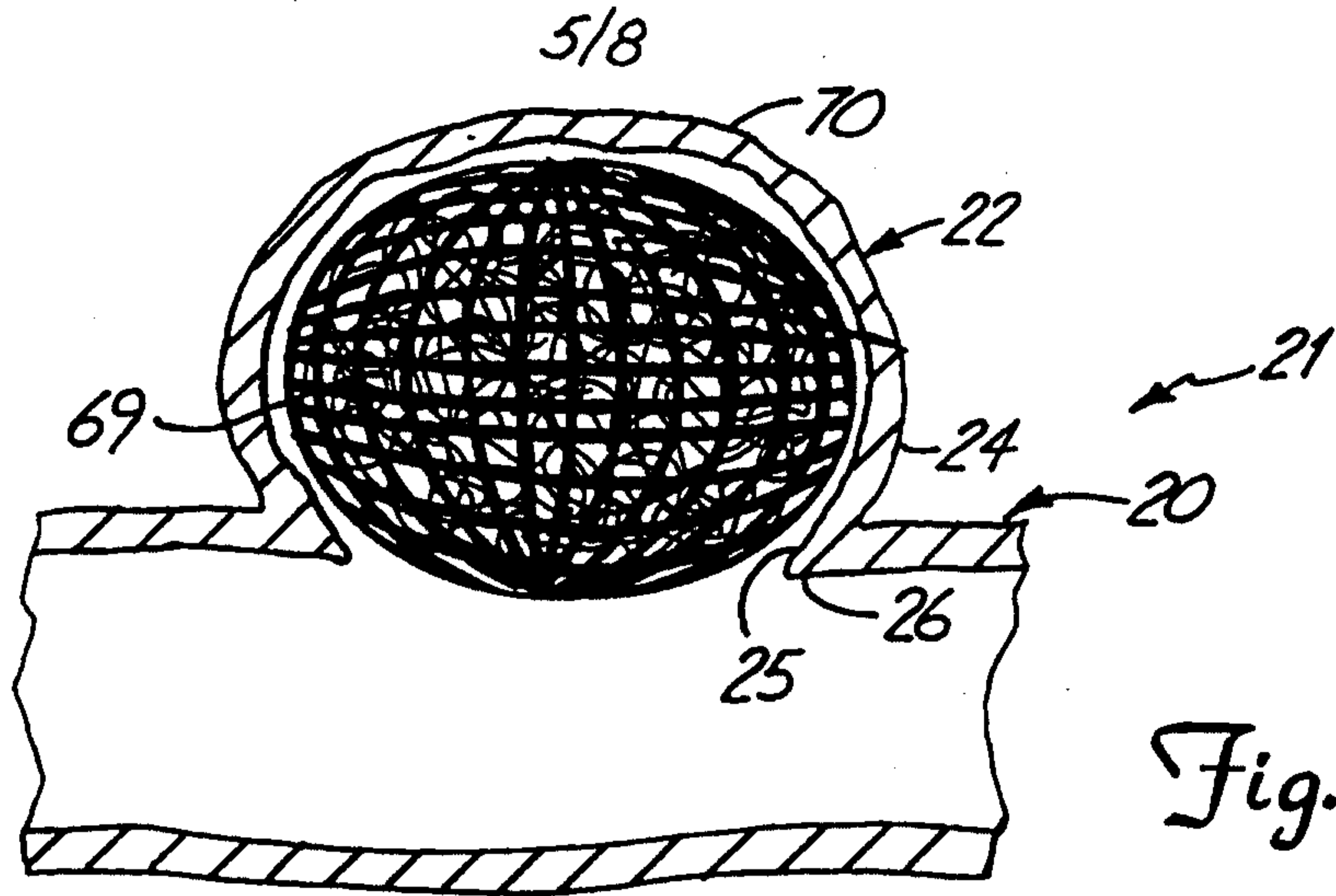

Fig. 6

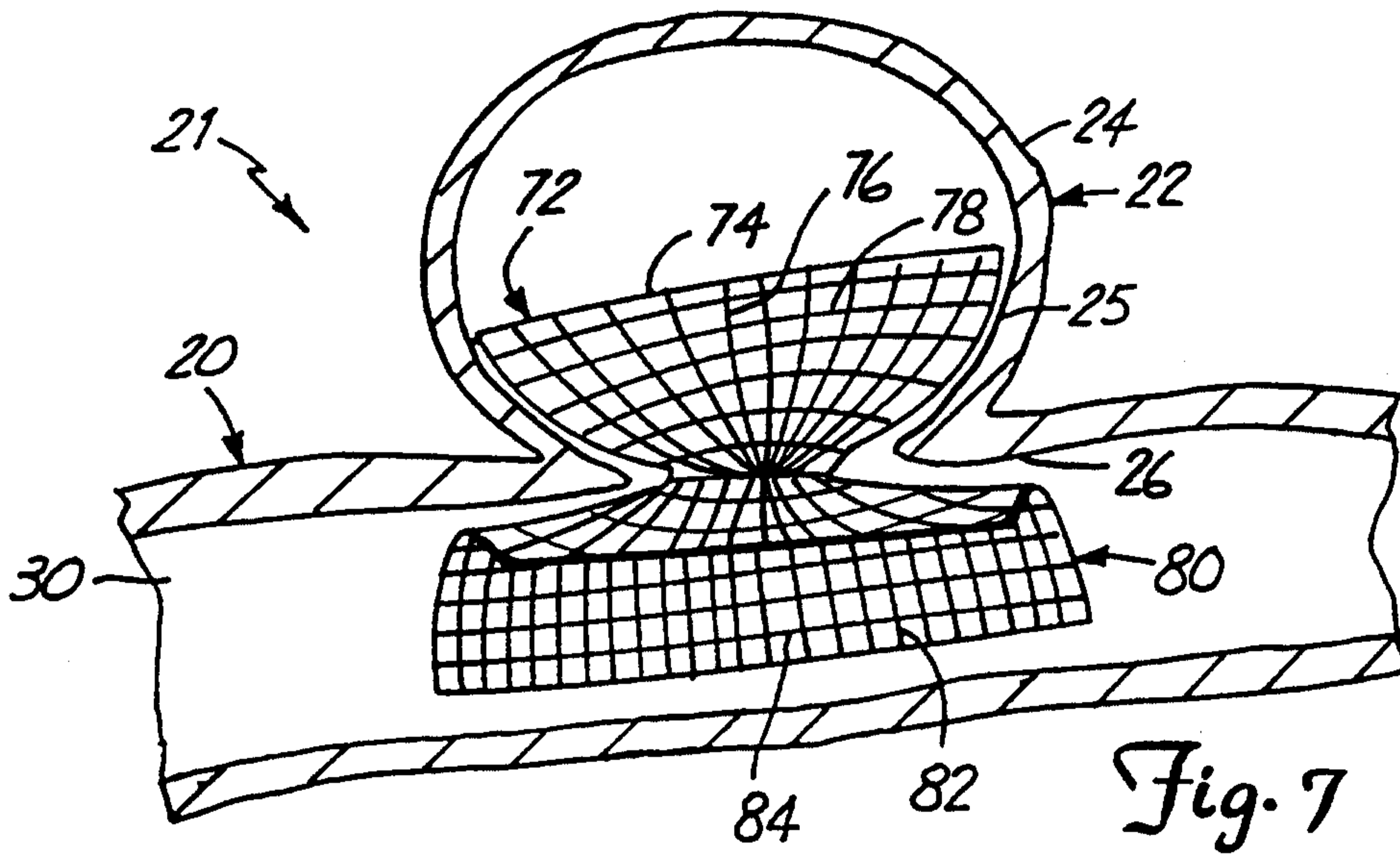

Fig. 7

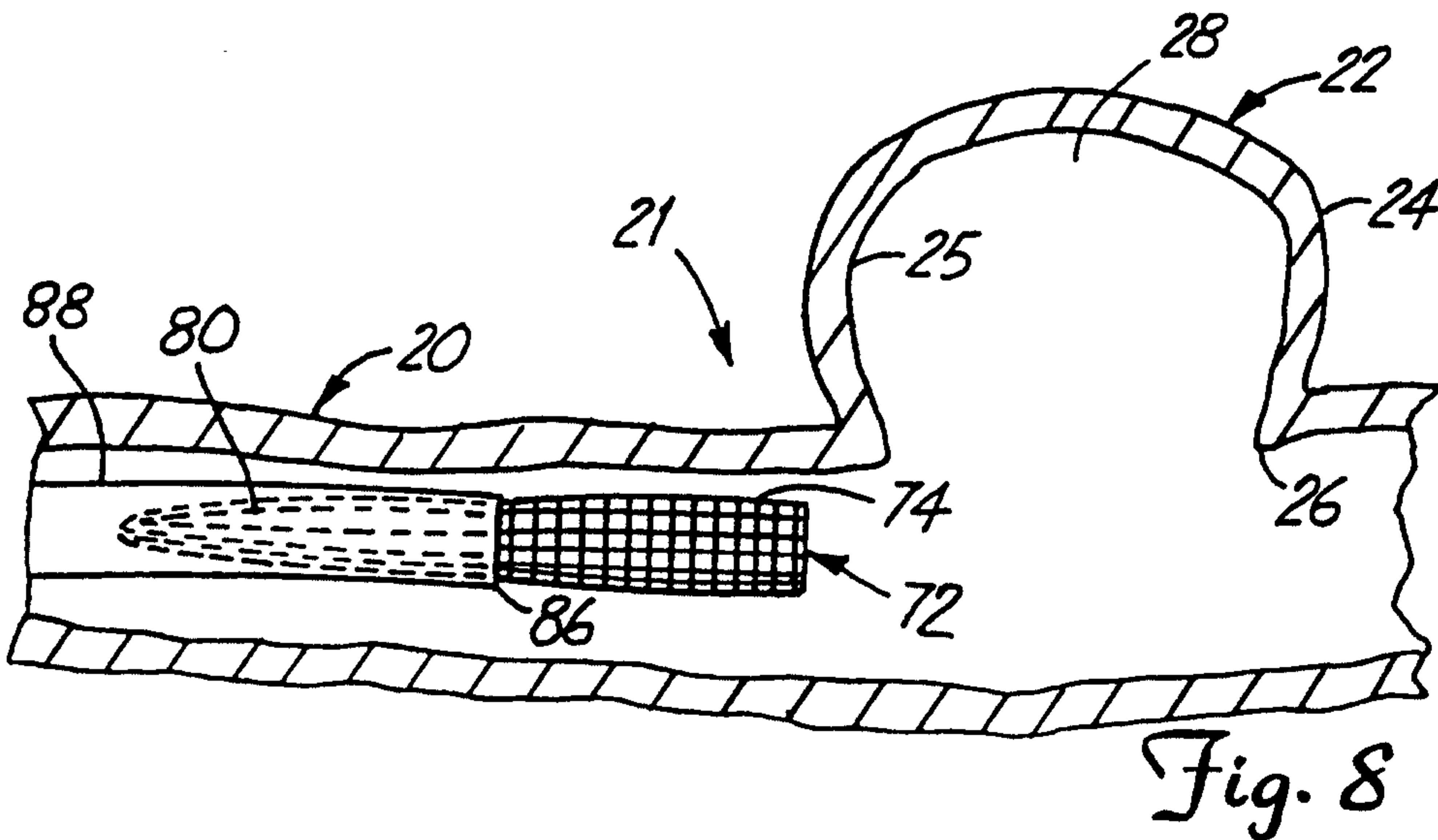

Fig. 8

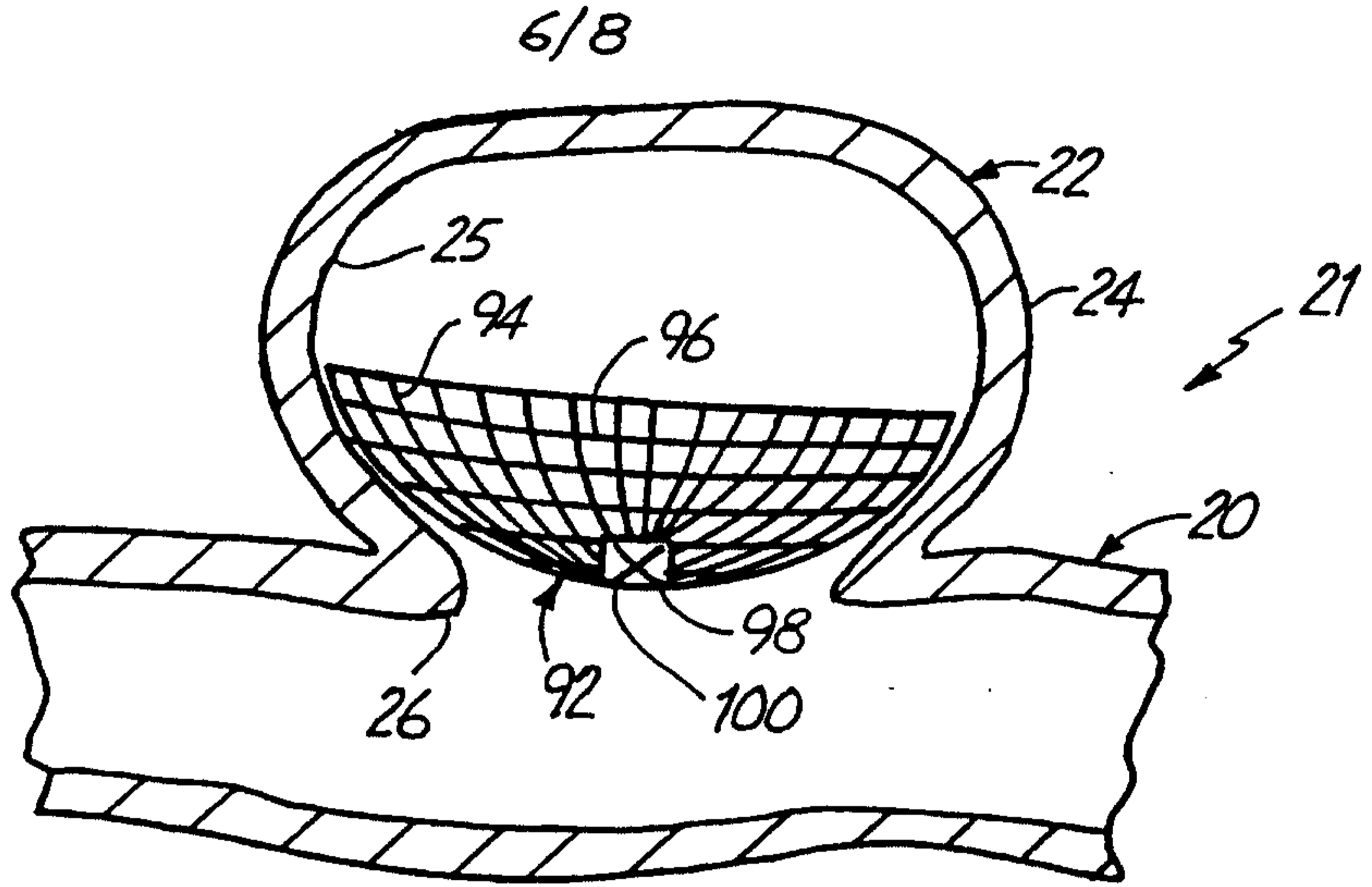

Fig. 9

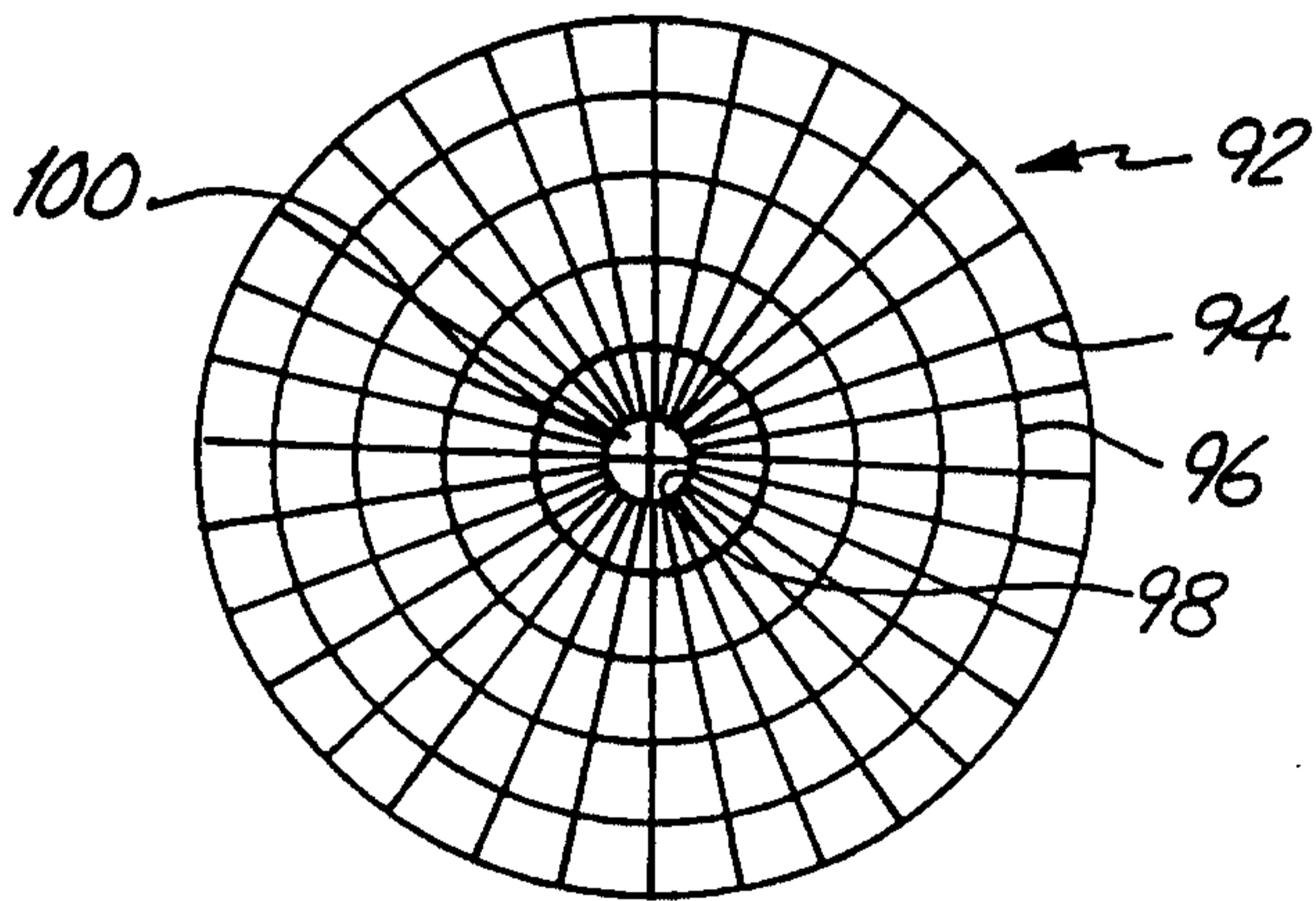

Fig. 10

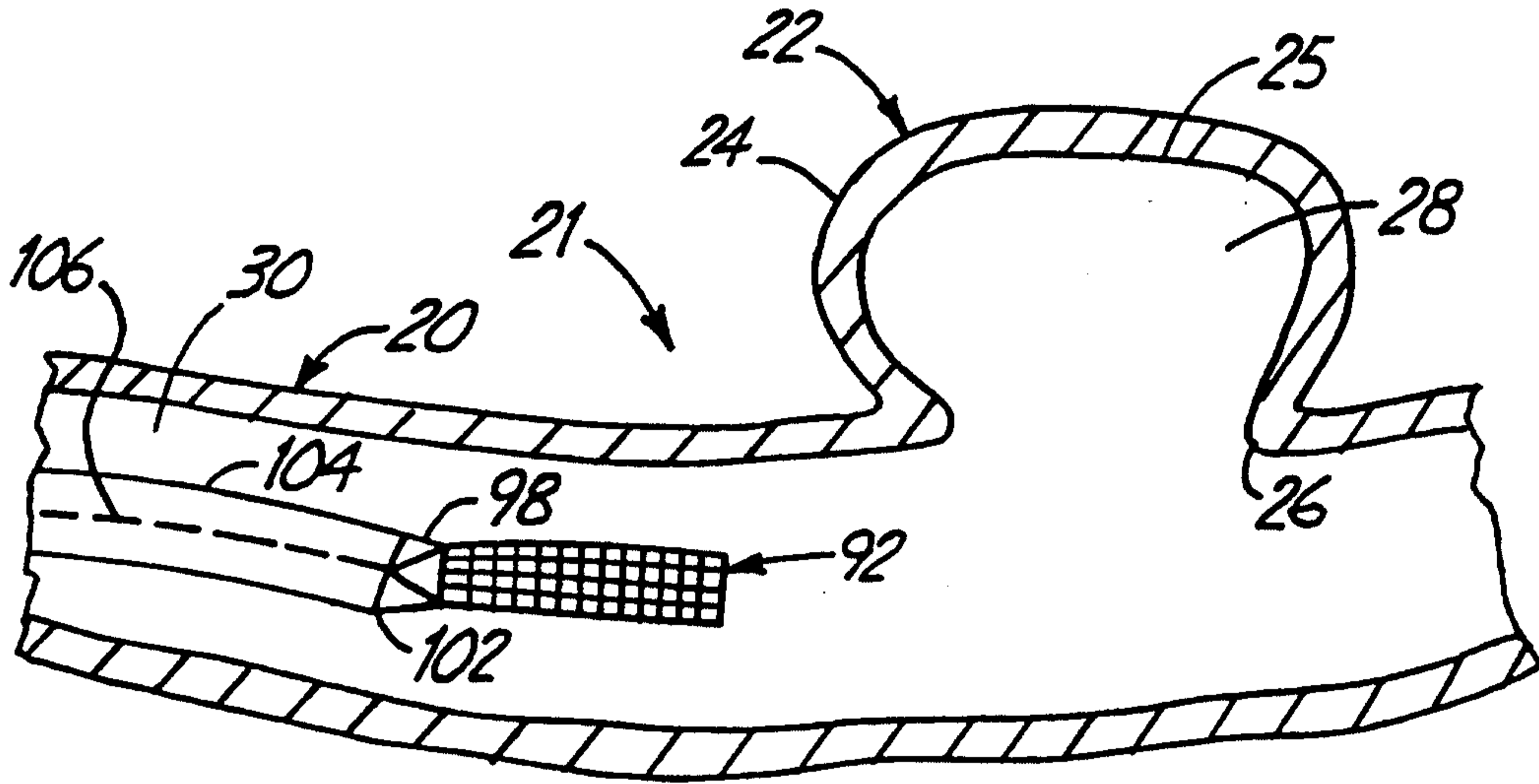

Fig. 11A

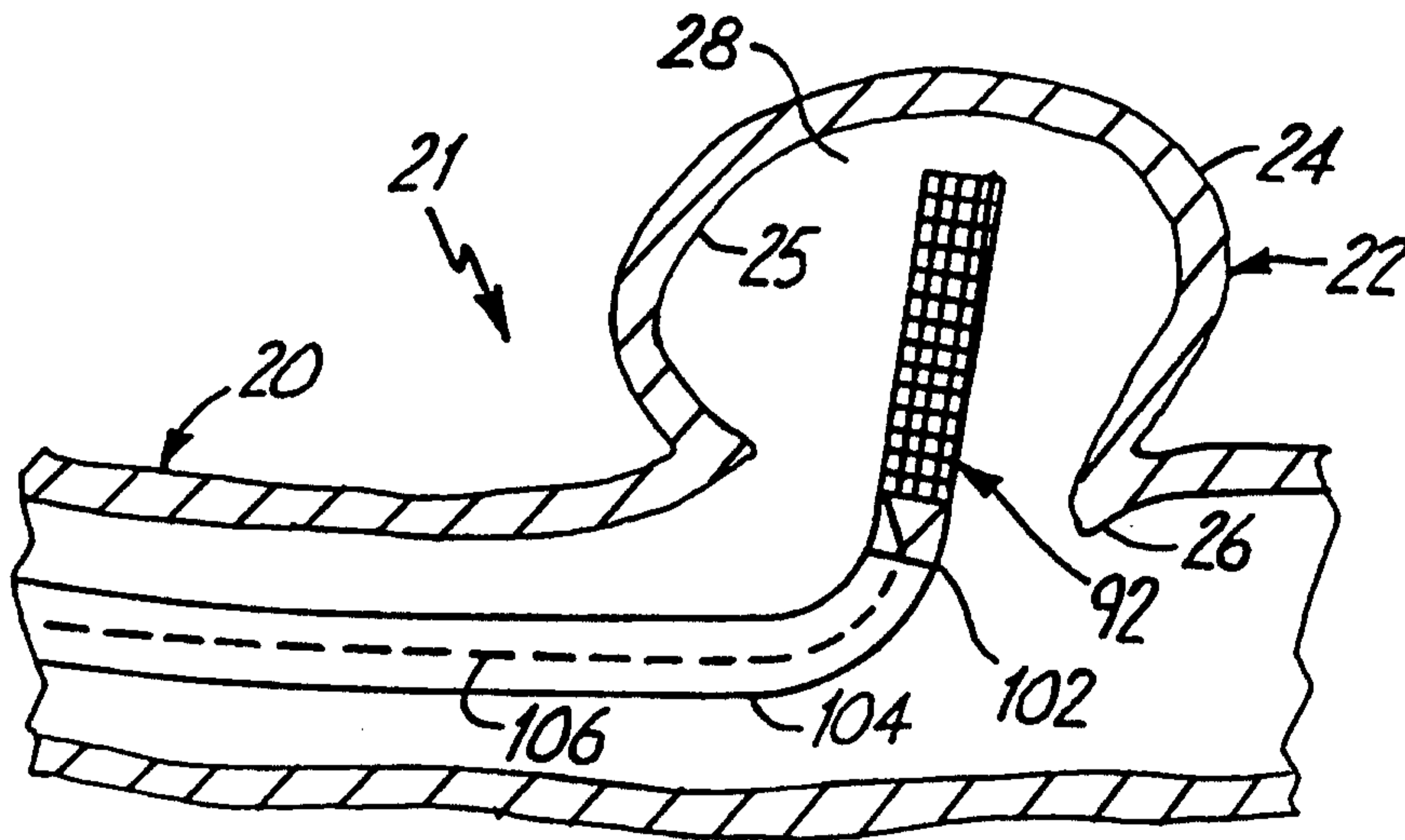

Fig. 11B

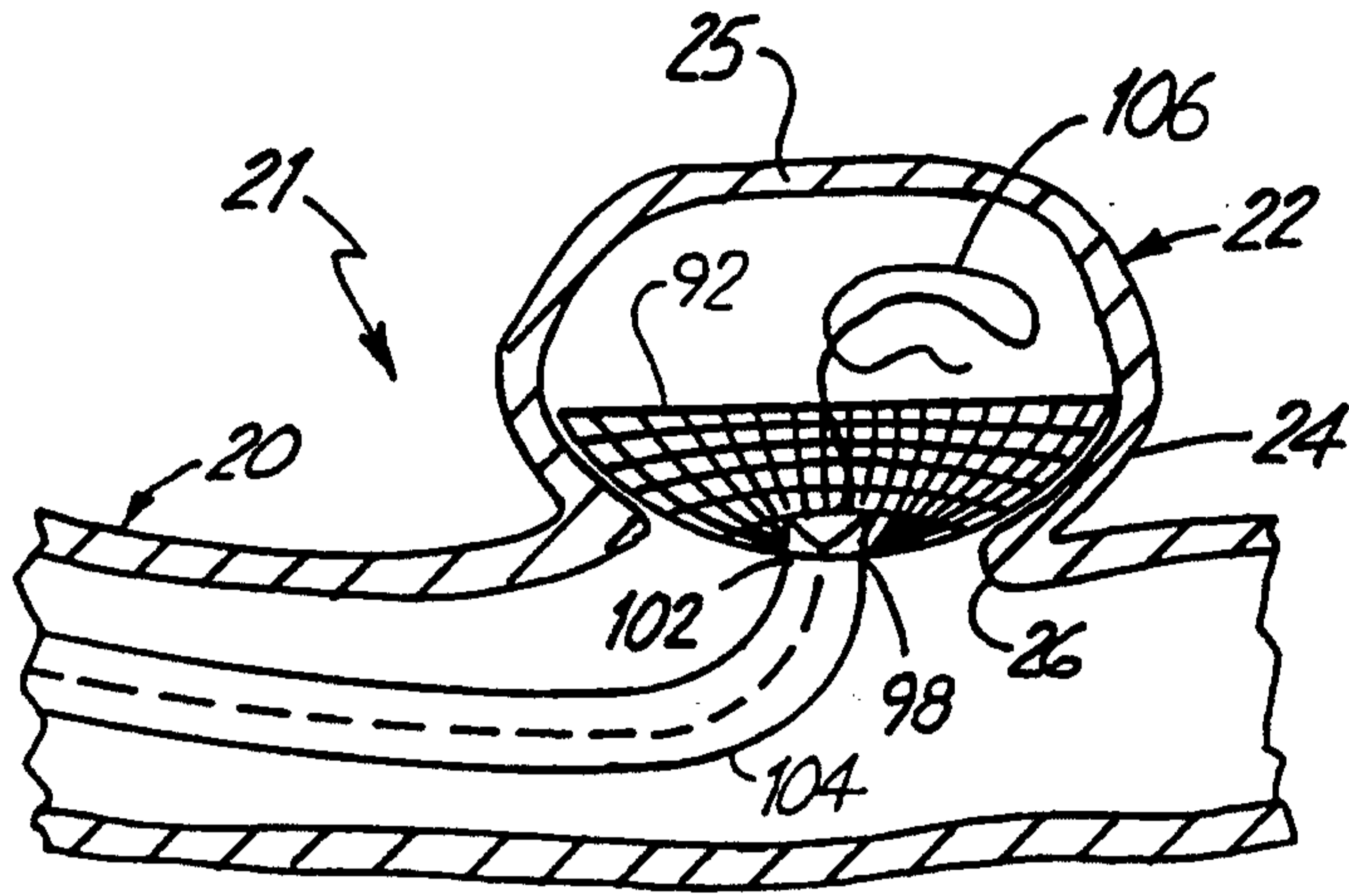

Fig. 11C

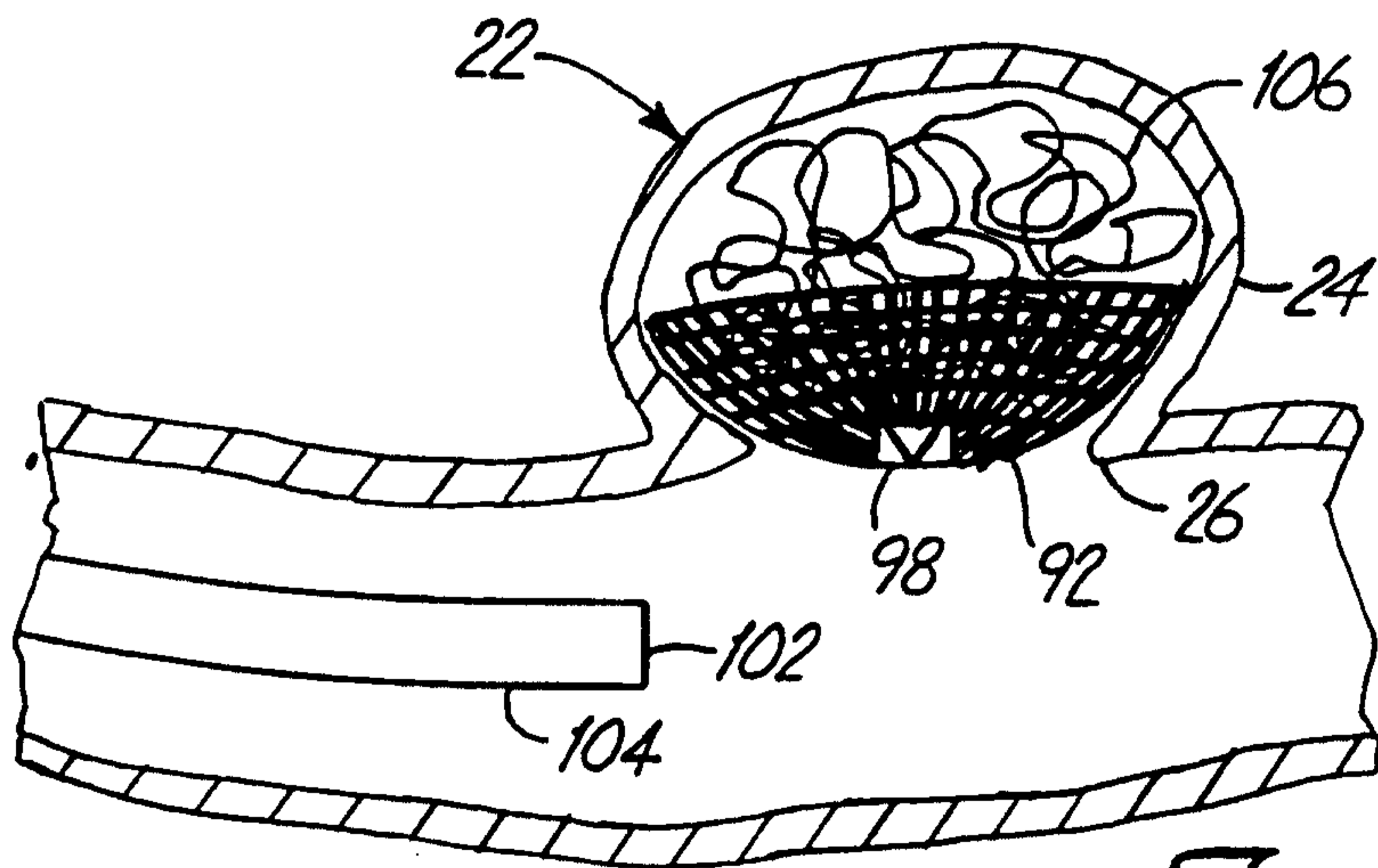

Fig. 11D