

(19)
(12)

(KR)
(A)

(51) 。 Int. Cl. ⁷
H01L 27/146

(11)
(43)

2002 - 0058457
2002 07 12

(21) 10 - 2000 - 0086563
(22) 2000 12 30

(71)

136 - 1

(72)

511 - 104

(74)

:

(54)

,

가

,

가

가

.

3b

, , , ,

1

CMOS

,

2a 2b ,

3a 3b ,

3c .

*

*

30: 31:

33: n 34: p

35: p

(image sensor) 1 2 .

semiconductor) CCD(charge coupled device) 2 가 MOS(metal - oxide -

CMOS MOS 가 CMOS 가 CCD 가 가 CMOS CMOS

1 4 2 CMOS (PD) 4 NMOS (Tx) CMOS (FD) NMOS (Rx) (PD) (FD) (Sx) (Dx) (Source Follower) (V_{DD}) 가 (Tx) (Sx) (on) (Rx), (PD) (carrier charging) (Tx) (SO) (Sx) V1 (VDD) (Rx)

(Tx)
(Out) V2 V1 - V2 Cp Cf

가 .

2a 1
, 2b 2a A - A' .

2b , p Si (10), n (13) p (14) PNP
(PD) 가 가 (11) SiO₂ (11) (bird's b
'12'

eak) Si (10) . 2b '12'

가 .

가 , 1 ;

; 가 ;

(LoCal Oxidation of Silicon)

가

가 ,

가 .

, 3a 3b , 3b 3a B - B' . 3a 3b

3a 3b , 1 (30),

(30) (30) (31), (31) (33),

(30) (32), (30) n (PD),

(PD) (30) p (41) p (35), (PD), (PD)

(31) (PD) (FD), (FD) (FD) (30)

(PD) (PD) (FD) (Rx) (D)

(Tx)
x) .

(30) , (31)

(35) (PD) (31) (30) 3c

(FD) 가 .

가 가 , 가 ,

가 .

(57)

1.

,

1 ;

;

;

가

.

2.

1 ,

,

2 ;

2

1

.

3.

1 2 ,

.

4.

3 ,

,

.

1

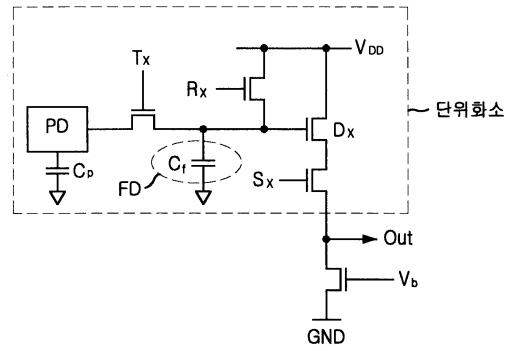

2a

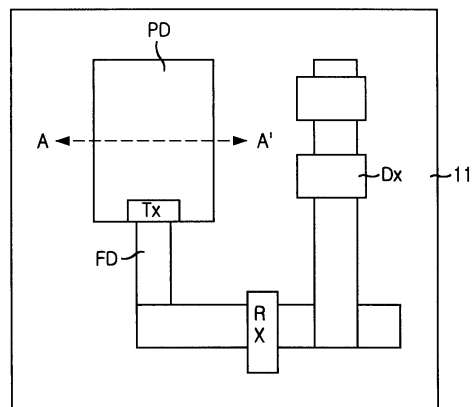

2b

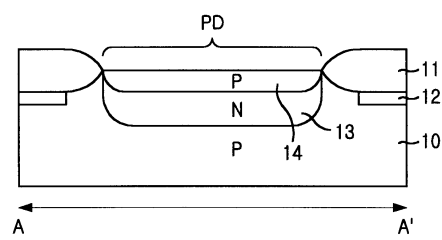

3a

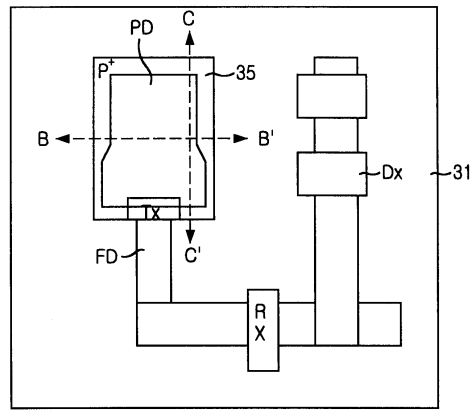

3b

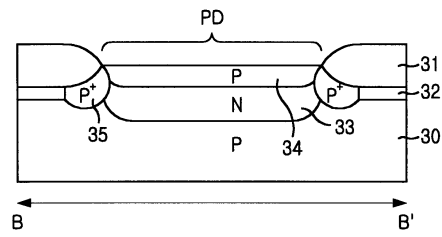

3c

