



(86) Date de dépôt PCT/PCT Filing Date: 2006/11/14  
 (87) Date publication PCT/PCT Publication Date: 2007/06/07  
 (45) Date de délivrance/Issue Date: 2012/01/24  
 (85) Entrée phase nationale/National Entry: 2008/03/27  
 (86) N° demande PCT/PCT Application No.: US 2006/060869  
 (87) N° publication PCT/PCT Publication No.: 2007/065055  
 (30) Priorité/Priority: 2005/11/29 (US11/289,006)

(51) Cl.Int./Int.Cl. *B65D 43/02* (2006.01),  
*B65D 51/20* (2006.01), *B65D 77/20* (2006.01)  
 (72) Inventeurs/Inventors:  
SCHUETZ, JEFFREY M., US;  
WESTPHAL, TEDDY M., US  
 (73) Propriétaire/Owner:  
SONOCO DEVELOPMENT, INC., US  
 (74) Agent: SIM & MCBURNEY

(54) Titre : COUVERCLE DE CONTENANT FORME SOUS FORME DE STRATIFIE DOTE D'UN ELEMENT D'OUVERTURE INTEGRE, CONTENANT COMPRENANT CE COUVERCLE ET PROCEDE DE FABRICATION DE CE COUVERCLE

(54) Title: CONTAINER LID FORMED AS A LAMINATE HAVING A BUILT-IN OPENING FEATURE, CONTAINER INCORPORATING SAME, AND METHOD FOR MAKING SAME

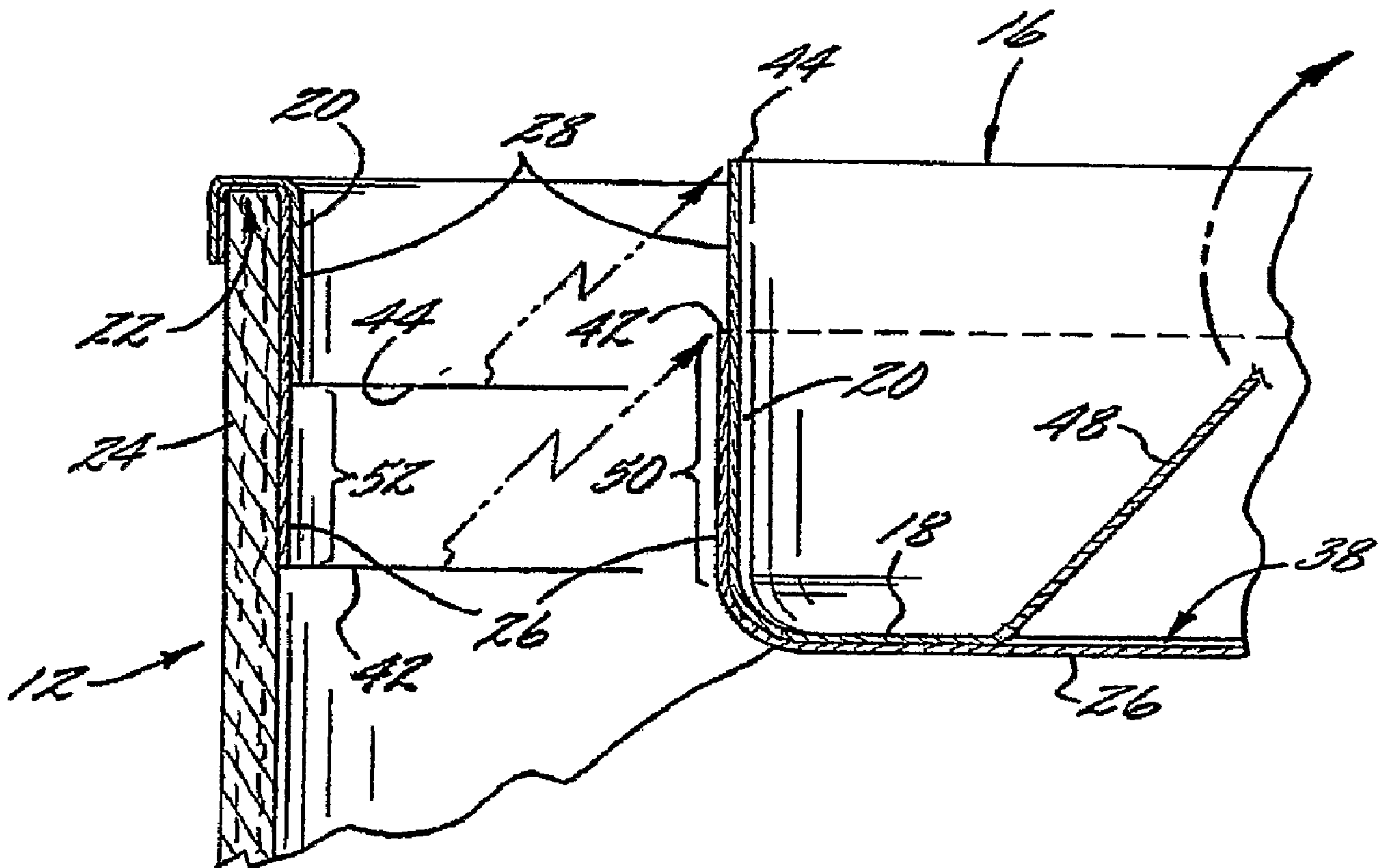

(57) Abrégé/Abstract:

A lid for a container having a built-in opening feature comprises a flexible laminate comprising an upper layer and a lower layer, a pair of radially spaced concentric lines of weakness being formed in the laminate, an outer one of the lines of weakness being

(57) **Abrégé(suite)/Abstract(continued):**

formed in the upper layer and an inner one of the lines of weakness being formed in the lower layer, wherein the upper and lower layers in an annular region between the lines of weakness are readily peeled apart, and wherein the upper and lower layers outside the annular region are laminated together with an adhesive providing a bond with a greater peel strength than that required to separate the layers in the annular region.

## (12) INTERNATIONAL APPLICATION PUBLISHED UNDER THE PATENT COOPERATION TREATY (PCT)

(19) World Intellectual Property Organization  
International Bureau(43) International Publication Date  
7 June 2007 (07.06.2007)

PCT

(10) International Publication Number  
**WO 2007/065055 A1**

## (51) International Patent Classification:

*B65D 43/02* (2006.01)      *B65D 77/20* (2006.01)  
*B65D 51/20* (2006.01)

## (21) International Application Number:

PCT/US2006/060869

## (22) International Filing Date:

14 November 2006 (14.11.2006)

## (25) Filing Language:

English

## (26) Publication Language:

English

## (30) Priority Data:

11/289,006      29 November 2005 (29.11.2005)      US

(71) Applicant (for all designated States except US):  
**SONOCO DEVELOPMENT, INC.** [US/US]; 1 North  
Second Street, Hartsville, SC 29550 (US).

## (72) Inventors; and

(75) Inventors/Applicants (for US only): **SCHUETZ, Jeffrey, M.** [US/US]; 812 Cloisters Drive, Florence, SC 29505 (US). **WESTPHAL, Teddy, M.** [US/US]; 708 Prince Alston Cove, Florence, SC 29501 (US).

(74) Agents: **HILL, Donald, M., Jr.** et al.; Alston & Bird LLP, Bank of America Plaza, 101 South Tryon Street, Suite 4000, Charlotte, NC 28280-4000 (US).

(81) Designated States (unless otherwise indicated, for every kind of national protection available): AE, AG, AL, AM, AT, AU, AZ, BA, BB, BG, BR, BW, BY, BZ, CA, CH, CN, CO, CR, CU, CZ, DE, DK, DM, DZ, EC, EE, EG, ES, FI, GB, GD, GE, GH, GM, GT, HN, HR, HU, ID, IL, IN, IS, JP, KE, KG, KM, KN, KP, KR, KZ, LA, LC, LK, LR, LS, LT, LU, LV, LY, MA, MD, MG, MK, MN, MW, MX, MY, MZ, NA, NG, NI, NO, NZ, OM, PG, PH, PL, PT, RO, RS, RU, SC, SD, SE, SG, SK, SL, SM, SV, SY, TJ, TM, TN, TR, TT, TZ, UA, UG, US, UZ, VC, VN, ZA, ZM, ZW.

(84) Designated States (unless otherwise indicated, for every kind of regional protection available): ARIPO (BW, GH, GM, KE, LS, MW, MZ, NA, SD, SL, SZ, TZ, UG, ZM, ZW), Eurasian (AM, AZ, BY, KG, KZ, MD, RU, TJ, TM), European (AT, BE, BG, CH, CY, CZ, DE, DK, EE, ES, FI, FR, GB, GR, HU, IE, IS, IT, LT, LU, LV, MC, NL, PL, PT, RO, SE, SI, SK, TR), OAPI (BF, BJ, CF, CG, CI, CM, GA, GN, GQ, GW, ML, MR, NE, SN, TD, TG).

## Declaration under Rule 4.17:

— as to applicant's entitlement to apply for and be granted a patent (Rule 4.17(ii))

## Published:

— with international search report

For two-letter codes and other abbreviations, refer to the "Guidance Notes on Codes and Abbreviations" appearing at the beginning of each regular issue of the PCT Gazette.

(54) Title: CONTAINER LID FORMED AS A LAMINATE HAVING A BUILT-IN OPENING FEATURE, CONTAINER INCORPORATING SAME, AND METHOD FOR MAKING SAME

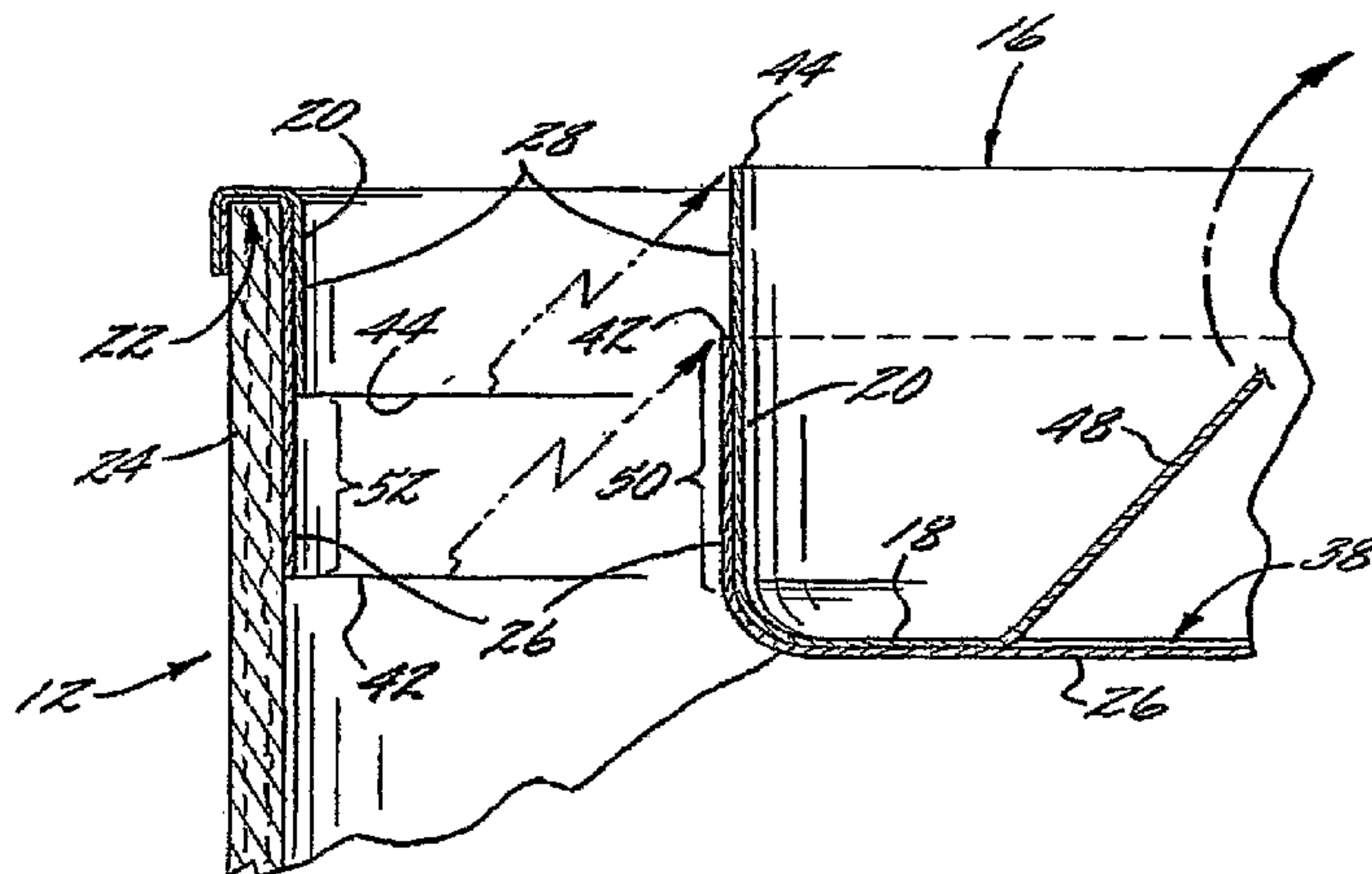

(57) Abstract: A lid for a container having a built-in opening feature comprises a flexible laminate comprising an upper layer and a lower layer, a pair of radially spaced concentric lines of weakness being formed in the laminate, an outer one of the lines of weakness being formed in the upper layer and an inner one of the lines of weakness being formed in the lower layer, wherein the upper and lower layers in an annular region between the lines of weakness are readily peeled apart, and wherein the upper and lower layers outside the annular region are laminated together with an adhesive providing a bond with a greater peel strength than that required to separate the layers in the annular region.

WO 2007/065055 A1

CONTAINER LID FORMED AS A LAMINATE HAVING A BUILT-IN  
OPENING FEATURE, CONTAINER INCORPORATING SAME,  
AND METHOD FOR MAKING SAME

BACKGROUND OF THE INVENTION

The present invention relates to containers sealed with flexible lids formed from materials such as polymer film, aluminum foil, paper, and the like.

It is known to seal a container with a lid formed from a heavy-gauge  
5 aluminum foil having a heat-sealable material on its underside. The lid is shaped to include a cylindrical skirt that extends upwardly from an outer periphery of a center panel of the lid, such that the heat-sealable material is on the radially outwardly facing side of the skirt. The skirt is heat-sealed to a generally cylindrical inner surface of the container body adjacent the open end of the  
10 container, the center panel of the lid thus being recessed below a top edge of the container body. The lid includes a line of weakness such that the center panel can be torn free of the skirt, at least part of which remains attached to the container body. A pull tab is attached to the top surface of the center panel to aid the user in tearing out the center panel. The pull tab typically is heat-sealed to the center  
15 panel. For example, a container and lid generally as described above are disclosed in U.S. Patent No. 4,744,484 to Grabher.

A difficulty associated with such container lids arises because of inevitable variations in the strength of the bond between the tab and the center panel. Such variations are due to mechanical process and material variations that are difficult to  
20 control or eliminate. Additionally, it has been found that the tab bond strength tends to diminish with aging of the lid. Accordingly, it can be expected that some proportion of the lids produced according to the conventional process will have a tab bond strength that is less than the force required to detach the center panel from

the skirt. When the user pulls on the tab of such a lid, the tab will tend to come off the center panel and the user will then have to resort to other means to open the container, such as puncturing the lid with a sharp implement and then tearing out the lid in pieces. This is inconvenient for the user.

5

#### BRIEF SUMMARY OF THE INVENTION

The present invention addresses the above needs and achieves other advantages, by providing a lid formed as a laminate having a built-in opening feature employing a different opening mechanism that is more-controllable in terms of opening force than the conventional type of lid described above. In accordance with one embodiment of the invention, a lid for a container comprises a flexible laminate comprising an upper layer and a lower layer, a pair of radially spaced concentric lines of weakness being formed in the laminate, an outer one of the lines of weakness being formed in the upper layer and an inner one of the lines of weakness being formed in the lower layer. Each line of weakness comprises a cut extending partially or entirely through the thickness of the respective layer, and allows the layer to sever along the line with little or no force. An annular region is thus defined between the lines of weakness. The upper and lower layers outside the annular region are laminated together with an adhesive providing a bond with a sufficient peel strength to keep the layers from separating when the lid is pulled to detach it from the container, and hence the inner layer severs along the inner line of weakness and the layers then separate from each other in the annular region until the outer line of weakness is reached. The outer layer then severs along the outer line of weakness so that the lid comes free of the container.

25           The separability of the layers in the annular region in some embodiments can be provided by disposing a readily peelable adhesive in the annular region between the layers. In other embodiments, the separability is achieved by providing no adhesive in the annular region. Thus, the layers are adhered to each other outside the annular region but are not adhered in the annular region.

30           Preferably, the lid is shaped to have a central panel that is generally disk-shaped and to have a generally cylindrical skirt joined to an outer periphery of the

central panel and extending upwardly therefrom such that the lower layer of the skirt faces radially outwardly. The skirt is structured and arranged to be bonded to the inner surface of a container body. The lines of weakness are both located on the skirt, with the outer line of weakness being spaced above the inner line of  
5 weakness.

Preferably, an integral tab is formed in the upper layer of the center panel. The tab is formed by cutting through the thickness of the upper layer along a generally U-shaped cut line. Preferably, there is no adhesive underlying the tab so that the tab can be lifted away from the lower layer of the lid and pulled to detach  
10 the center panel from the skirt.

The upper layer of the lid can be a monolayer or a multilayer structure. For instance, the upper layer can be a single layer of polymer film such as polyester (e.g., PET). Alternatively, the upper layer can be a lamination of a polymer film such as polyester and a barrier layer such as aluminum foil.

15 In embodiments employing adhesive in the annular region, the adhesive preferably is a pressure-sensitive adhesive (PSA). Outside the annular region a different adhesive, such as a conventional laminating adhesive, is employed. The PSA "bridges the gap" between the lines of weakness. Preferably, the PSA also extends somewhat outward of the outer line of weakness and somewhat inward of  
20 the inner line of weakness so that slight errors in the locations of the lines of weakness because of manufacturing tolerances will not result in either line of weakness being in a location where the stronger laminating adhesive is present.

In yet other embodiments of the invention, a readily peelable adhesive providing a relatively low peel strength can be disposed both outside and within  
25 the annular region between the score lines. For example, the adhesive can be flood-coated onto one of the layers prior to lamination.

In operation, the tab is pulled upwardly and generally away from the portion of the skirt adjacent the tab. Initially, a portion of the skirt adjacent the outer periphery of the center panel begins to detach from the container body until

the inner (lower) line of weakness is reached, and then the lower layer begins to sever along the inner line of weakness. Further pulling of the center panel away from the skirt causes the upper layer to begin separating from the lower layer in the annular region between the lines of weakness. In those embodiments in which no adhesive is present in the annular region, the upper layer will immediately separate from the lower layer up to the outer (upper) line of weakness. In other embodiments in which PSA is present in the annular region, the PSA allows the layers to readily peel apart. When the outer (upper) line of weakness is reached, the upper layer begins to sever along the outer line of weakness, and the center panel finally is completely detached from the skirt, which remains attached to the container body.

The invention also provides a container having a lid as described above.

A method for making a lid in accordance with one embodiment of the invention comprises the steps of: (1) forming a first line of weakness in a first polymer film layer, the first line of weakness extending in a closed loop about a center point on the first polymer film layer, the first line of weakness weakening the first polymer film layer such that severing of the first polymer film layer preferentially occurs along the first line of weakness; (2) forming a second line of weakness in a second polymer film layer, the second line of weakness extending in a closed loop about a center point on the second polymer film layer and being configured such that when the first and second polymer film layers are superimposed on each other with the respective center points aligned, the second line of weakness is substantially concentric with and spaced radially inward from the first line of weakness such that an annular region of each polymer film layer is defined between the first and second lines of weakness; (3) applying an adhesive to areas of one of the first and second polymer film layers at least outside the annular region; and (4) superimposing the first and second polymer film layers upon each other with the respective center points aligned such that the polymer film layers are laminated together by the adhesive to form a laminate.

The method preferably also includes the steps of cutting the laminate along a cut line extending in a closed loop about the aligned center points and lying radially outward of the first line of weakness so as to form a disk-shaped laminate, and deforming the disk-shaped laminate to form a cylindrical skirt that extends  
5 upwardly from an outer periphery of a center panel of the disk-shaped laminate, the skirt being formed such that the second polymer film layer faces radially outward and the first polymer film layer faces radially inward relative to the center points. The deforming step is carried out such that both the first and second lines of weakness are located on the skirt, the first line of weakness being spaced above  
10 the second line of weakness. The lid can be formed while disposed atop the container, such that the lid is urged down into the container and shaped to have the skirt, which can extend up over the top edge of the container body. Vacuum can be used to hold the lid in place and then a heat-seal tool can be moved into the container to heat the skirt to seal the skirt to the container body.

15 In a preferred embodiment, an integral tab is formed in the center panel by cutting the first layer along a generally U-shaped cut line. The adhesive-applying step preferably is carried out such that the polymer film layers are free of adhesive in the tab region, so that the tab can be lifted away from the second layer.

In an alternative embodiment of the invention, the laminate for forming the  
20 lid includes an inner line of weakness in the lower layer as described above, but the outer line of weakness is omitted. The upper and lower layers are adhered over their entire surfaces with an adhesive such as a low bond-strength adhesive or PSA. The lid is formed such that the skirt terminates at its top end on the inner surface of the container body. In operation, the tab is pulled upwardly and  
25 generally away from the portion of the skirt adjacent the tab. Initially, a portion of the skirt adjacent the outer periphery of the center panel begins to detach from the container body until the inner line of weakness is reached, and then the lower layer begins to sever along the inner line of weakness. Further pulling of the center panel away from the skirt causes the upper layer to peel away from the lower layer  
30 until the top end of the skirt is reached, at which point the center panel comes free of the container.



## BRIEF DESCRIPTION OF THE SEVERAL VIEWS OF THE DRAWING(S)

Having thus described the invention in general terms, reference will now be made to the accompanying drawings, which are not necessarily drawn to scale, and  
5 wherein:

FIG. 1 is a perspective view of a container incorporating a lid in accordance with one embodiment of the invention;

FIG. 2 is a perspective view of the lid;

FIG. 3 is a top elevation of the lid;

10 FIG. 4 is a greatly magnified cross-sectional view along line 4-4 in FIG. 1;

FIG. 5 is a diagrammatic depiction of a method for making a lid in accordance with one embodiment of the invention;

FIG. 6A is a perspective view illustrating a first step of a procedure for opening the container in accordance with one embodiment of the invention;

15 FIG. 6B is a view similar to FIG. 6A, showing a further step of the opening procedure;

FIG. 7 is a cross-sectional view taken along line 7-7 in FIG. 6B, showing the lid after its detachment from the container body;

20 FIG. 8A is a greatly magnified cross-sectional view depicting a tooling assembly and a first step of a process for shaping a lid blank into a lid and inserting the lid into a container body in accordance with one embodiment of the invention;

FIG. 8B is a view similar to FIG. 8A, showing a second step of the shaping and inserting process;

25 FIG. 9A is a view similar to FIG. 4, showing another embodiment of the invention; and

FIG. 9B shows the other embodiment after removal of the lid.

#### DETAILED DESCRIPTION OF THE INVENTION

The present inventions now will be described more fully hereinafter with  
5 reference to the accompanying drawings, in which some, but not all embodiments  
of the inventions are shown. Indeed, these inventions may be embodied in many  
different forms and should not be construed as limited to the embodiments set forth  
herein; rather, these embodiments are provided so that this disclosure will satisfy  
applicable legal requirements. Like numbers refer to like elements throughout.

10 A container **10** in accordance with one embodiment of the invention is  
illustrated in FIG. 1. The container comprises a tubular container body **12**, a  
bottom end closure **14** affixed to a bottom end of the container body, and a top end  
closure or lid **16** affixed to a top end of the container body. The lid **16** has a built-  
in opening feature facilitating removal of a portion of the lid to gain access to the  
15 contents of the container. After the initial opening, a separate overcap **17** or the  
like can be engaged on the top end of the container body to keep any remaining  
contents from being exposed to the atmosphere.

The lid **16** is formed from a laminate of flexible sheet materials. As further  
described below, the laminate is die-cut to produce a disk-shaped laminate or lid  
20 blank that is subsequently shaped by suitable tooling into a form as best seen in  
FIGS. 2 and 4. The lid has a generally planar center panel **18** and a generally  
cylindrical skirt **20** that extends upwardly from an outer periphery of the center  
panel. A top end of the skirt can be shaped to curl outwardly and downwardly so  
as to define a channel **22** (FIG. 4) that receives the top edge of the side wall **24** of  
25 the container body. The center panel **18** is recessed below the top edge of the  
container body side wall **24**, as best seen in FIG. 4. The skirt **20** is bonded to the  
inner surface of the container body side wall **24** to seal the top end of the container  
closed.

With reference to FIG. 5, a method is now described for producing a  
30 laminate from which the lid **16** is made. The laminate is constructed from a lower

layer **26** of flexible sheet material and an upper layer **28** of flexible sheet material. The lower layer **26** preferably comprises a polymer film that is heat-sealable to a heat-sealable material disposed on the inner surface of the container body side wall. Suitable examples of such heat-sealable polymer films include but are not limited to polyolefins such as polypropylene, polyethylene, and the like, or an ionomer resin such as SURLYN® or the like. The upper layer **28** preferably comprises a polymer film. Suitable examples of polymer films for the upper layer include but are not limited to polyester such as polyethylene terephthalate (PET), metallized PET, oriented polypropylene (OPP), metallized OPP, or the like. If desired for barrier and/or appearance reasons, the upper layer can be metallized by vapor-depositing a thin layer of substantially pure metal such as aluminum onto one surface of the film. The upper layer also can comprise a multilayer laminated structure such as a polymer film laminated to a barrier layer (e.g., aluminum foil). The upper and lower layers are adhesively laminated together to form a laminate **30**. The melting temperature of the upper layer desirably should be higher than that of the lower layer by a sufficient margin to ensure that heating of the laminate for heat-sealing the lower layer to a container body side wall does not cause melting of the upper layer.

In one embodiment, a lower surface of the upper layer **28** that faces the lower layer is pattern-printed with an adhesive **34**. The adhesive **34** is a laminating adhesive formulated to bond the layers together with a substantially higher bond strength than the first adhesive such that the layers bonded together by the adhesive are not readily peelable from each other. The laminating adhesive can be, for example, a two-component polyurethane adhesive system, such as Tycel 7900/7283 available from Henkel. The laminating adhesive **34** is applied to the upper layer in such a manner that a sufficiently large proportion of the surface is covered by the adhesive to permit the upper layer to be adhesively attached to the lower layer **26** at a downstream laminating station. The laminating adhesive **34** is not applied to an annular region **36** of the upper layer. In this embodiment, the annular region **36** is free of adhesive. The annular region **36** is dimensioned to occupy the area of the skirt **20** of a lid fashioned from the laminate **30**. The

adhesive 34 is applied to those areas outside the annular region 36, except that a region 38 that lies within the interior of the annular region 36 is kept free of adhesive for reasons soon to become apparent. Thus, the laminating adhesive must be applied by an apparatus capable of accurately applying the adhesive in a predetermined pattern, in registration with the pressure-sensitive adhesive but not covering it. A suitable adhesive application device can be a gravure roll.

In another embodiment, a lower surface of the upper layer 28 that faces the lower layer is pattern-printed with a first adhesive 32 as well as with a second adhesive 34. The first adhesive 32 is applied to the annular region 36 of the upper layer. The second adhesive 34 is applied to those areas outside the annular region 36, except that a region 38 that lies within the interior of the annular region 36 is kept free of adhesive as in the prior embodiment above. The first adhesive 32 is formulated to allow the layers bonded together by the adhesive to be readily peeled apart with relatively low peel force. The first adhesive advantageously can comprise a pressure-sensitive adhesive (PSA). Pressure-sensitive adhesives are often based on non-crosslinked rubber adhesives in a latex emulsion or solvent-borne form, or can comprise acrylic and methacrylate adhesives, styrene copolymers (SIS / SBS), and silicones. Acrylic adhesives are known for excellent environmental resistance and fast-setting time when compared with other resin systems. Acrylic pressure-sensitive adhesives often use an acrylate system. Natural rubber, synthetic rubber or elastomer sealants and adhesives can be based on a variety of systems such as silicone, polyurethane, chloroprene, butyl, polybutadiene, isoprene, or neoprene. When the laminate of the invention is to be used for food packaging, the pressure-sensitive adhesive generally must be a food-grade composition. Various pressure-sensitive adhesives are approved by the U.S. Food and Drug Administration for use in food packaging, as regulated by 21 CFR Part 175. A preferred food-grade pressure-sensitive adhesive for use in the present invention is Jonbond 743 available from Bostik Findley. Additives (e.g., particulates or the like) can be added to the pressure-sensitive adhesive to reduce the tenacity of the bond, if desired.

As evident from FIG. 5, the lower and upper layers 26, 28 advantageously comprise continuous lengths of the film material drawn from supply rolls (not shown) and advanced by web-handling equipment through a series of work stations at which different operations are performed on the layers. Thus, for example, the upper layer 28 is advanced to a pattern-printing station at which the adhesive 34, or both adhesives 32, 34, is/are pattern-printed onto the lower surface of the film using suitable equipment such as a gravure roll or the like. The adhesive is applied in a recurring pattern that repeats at intervals  $d$  (referred to as the "index distance") along the length of the film so that multiple lids can be die-cut in proper register from the laminate 30 in a continuous manufacturing process. The upper layer 28 advantageously has a repeating eye mark 40 or other feature that is present on the layer at intervals equal to the index distance  $d$  and is detectable by an optical detector (not shown) or the like for purposes of controlling the timing of certain operations during the production of the laminate. After the adhesive application at the adhesive-application station, the layers 26, 28 are brought together in superimposed relation and laminated together at a laminating station (not shown) to form the laminate 30.

The laminate is then advanced to a cutting station (not shown) at which a pair of lines of weakness are formed in the laminate. More specifically, an inner line of weakness 42 is formed in the lower layer 26. The inner line of weakness 42 comprises a cut extending partially, or preferably entirely, through the thickness of the lower layer, and can be formed by mechanical technique such as die-cutting (so-called "kiss" cutting). Alternatively, the line of weakness can be formed by use of a laser. The use of lasers for scoring through polymer films and laminates is generally known, for example as described in U.S. Patent No. 5,158,499.

The depth of the score line formed by the laser can be regulated by regulating the power output or beam intensity of the laser beam, the width or spot size of the laser beam, and the amount of time a given spot on the film surface is irradiated by the beam. These factors generally are selected based on the characteristics of the material being scored. Some materials are more readily scored by lasers than other materials, as known in the art. At any rate, the

line of weakness **42** weakens the lower layer so that severing of the lower layer will occur preferentially along the line of weakness. The inner line of weakness extends in a closed loop about a center point of the annular region **36**. Preferably, the inner line of weakness **42** is circular and is concentrically positioned with respect to the annular region **36**, and is slightly greater in radius than the radially innermost extent of the annular region **36**.

An outer line of weakness **44** is formed in the upper layer **28**. The outer line of weakness **44** comprises a cut extending partially, or preferably entirely, through the thickness of the upper layer, and can be formed by mechanical technique such as die-cutting or by use of a laser. The line of weakness **44** weakens the upper layer so that severing of the upper layer will occur preferentially along the line of weakness. The outer line of weakness **44** extends in a closed loop about the center point of the annular region **36**, and advantageously is circular and is concentrically positioned with respect to the inner line of weakness **42** and larger in radius than the inner line of weakness. The outer line of weakness **44** preferably is slightly smaller in radius than the radially outermost extent of the annular region **36**.

Additionally, at the cutting station, preferably the outer layer **28** is die-cut or laser-cut along a generally U-shaped cut line **46** that extends through the full thickness of the upper layer, so as to form an integral pull tab **48** in the upper layer. The cut line **46** is located in the adhesive-free region **38** of the laminate so that the tab **48** can be lifted away from the lower layer **26** and grasped and pulled to open the container. Proper registration of the lines of weakness **42**, **44** and cut line **46** with respect to the adhesive-free or PSA region **36** and the adhesive-free region **38** is achieved through the detection of the eye marks **40** on the laminate with an optical detector (not shown) and suitable control of the cutting equipment based on signals from the optical detector, as would be understood by one of ordinary skill in the art.

After the cutting station, the laminate is die-cut to cut out the individual lids from the laminate. For each lid, the laminate is cut along a circular cut line that is

greater in radius than the outer line of weakness 44 and is concentric with respect thereto.

With reference to FIG. 4, as noted, a lid 16 is shaped by suitable tooling so that an outer peripheral portion of the disk-shaped laminate forms a cylindrical skirt 20 having a diameter corresponding to an inner diameter of the container body side wall 24. The lid can be shaped prior to being placed onto the container, although this generally will be practical only for laminates that can hold a deformed shape after the deforming forces are removed, such as laminates having a layer of aluminum foil or the like.

Alternatively, the lid shaping can be accomplished concurrently with placing the lid onto the container, as further described below in connection with FIGS. 8A and 8B.

The skirt 20 is heat-sealed to the inner surface of the container body side wall, which typically includes an impervious liner (not shown) whose inner surface has a heat-sealable material. If desired, the shaping of the lid to form the skirt and the heat-sealing of the skirt to the side wall can be accomplished substantially simultaneously. Preferably, the full axial extent of the skirt is heat-sealed to the container body side wall, including a portion 50 of the skirt extending below the inner line of weakness 42.

In operation, as illustrated in FIGS. 6A and 6B, the lid 16 is opened by lifting, grasping, and pulling the tab 48 generally upwardly and radially inwardly. The portion 50 of the skirt begins to detach from the inner surface of the side wall 24, beginning at the bottom end of the portion 50 and proceeding up toward the inner line of weakness 42. When the inner line of weakness 42 is reached, the lower layer 26 begins to sever along the inner line of weakness 42, such that now the upper layer 28 is able to start separating from the lower layer. The upper layer 28 thus begins to separate from the lower layer 26 along the annular region 52 defined between the lines of weakness 42, 44. The layers in the annular region 52 are either unadhered to each other or are joined by the PSA so that the upper layer

readily separates from the lower layer, finally reaching the outer line of weakness 44. At that point, the outer layer 28 severs along the outer line of weakness, and the center panel 18 of the lid and the part of the skirt up to the outer line of weakness 44 are removed (FIG. 7). The part of the skirt above the outer line of weakness 44 remains attached to the container body side wall, as does a portion of the lower layer 26 between the lines of weakness 42, 44.

Accordingly, the opening mechanism of the lid relies on the separation of the layers 26, 28 in the adhesive-free or PSA region 36. The force needed to separate the layers in the region 36 is low enough so that the lid will open reliably, eliminating or at least greatly reducing the incidence of opening failures caused by inadvertent tab detachments or the like. The provision of an integral tab 48 further aids in preventing such failures, and saves on material and process costs ordinarily required for making and attaching a separate tab. However, it is within the scope of the invention to employ a separate tab attached to the upper layer 28.

As noted, the lid blank formed from the laminate 30 can be shaped to form the lid simultaneously with placing the lid into the container. FIGS. 8A and 8B illustrate an exemplary tooling assembly and process for carrying this out. A lid blank *B* is placed atop a container body 12 and a shaping tool 100 is arranged coaxially with respect to the longitudinal center axis of the container body into engagement with the lid blank and is moved along the center axis into the interior of the container body to press the blank down into the container body. The tool 100 includes a first or end portion 102 of cylindrical configuration having an outer diameter sufficiently smaller than the inner diameter of the container body so that the end portion 102 with the lid blank draped thereover fits into the container body with a relatively loose fit, but with the cylindrical skirt thereby formed in the lid engaging the inner surface of the container body. The tool includes a second portion 104 having an outer diameter approximately matching the outer diameter of the container body, and a shoulder 106 is defined at the transition between the first portion 102 and the second portion 104. The tool further includes a third portion 108 of still larger diameter than the second portion 104.



The tooling assembly further comprises a first ring **110** having an inner diameter slightly larger than the outer diameter of the container body **12**, the first ring surrounding the container body to provide support to the container body in the radially outward direction. The first ring **110** is axially movable relative to the container body and is urged by a diagrammatically illustrated spring **112** in the axially upward direction. The tooling assembly also includes a second ring **114** that is slightly larger in inner diameter than the first ring **110** and larger in inner diameter than the outer diameter of the second portion **104** of the tool **100**. The second ring **114** surrounds the container body and is disposed between the third portion **108** of the tool **100** and the first ring **110**. A diagrammatically illustrated spring **116** urges the second ring **114** away from the tool **100** in the axially downward direction toward the first ring **110**. As the lid shaping and inserting process begins, the lid blank is placed atop the container body and the first ring **110** and then the tool **100** and second ring **114** are moved as a unit to capture an outer edge of the lid blank **B** between the two rings **110, 114**.

As illustrated in FIG. 8A, as the tool **100** is further axially advanced downward into the container body, the lid blank **B** is shaped to conform to the container body so as to form the skirt **20** of the lid. A cylindrical mandrel **120** having a vacuum passage **122** therethrough is disposed in the container body with its end face at an appropriate axial position with respect to the top edge of the container body so as to delimit the movement of the lid into the container body. Thus, the tool **100** pushes the lid blank down until it contacts the end face of the mandrel **120** and vacuum is exerted through the vacuum passage **122** to hold the lid in place when the tool **100** is subsequently withdrawn. As the tool **100** moves down toward the mandrel **120**, the outer peripheral portion of the lid blank is still retained between the rings **110, 114**, although the clamping force is sufficiently small to allow the blank to slide relative to the rings so that the lid can be shaped into the container without substantially stretching. Eventually, the shoulder **106** of the tool **100** abuts the blank atop the top edge of the container body, at which point the rings **110, 114** have moved to the position shown in FIG. 8B so that the outer

edge portion of the lid blank wraps up over the top edge of the container body and onto the outer surface of the body for a short distance.

The next step in the process is to heat-seal the skirt **20** to the inner surface of the container body. This can be accomplished by raising the temperature of the tool **100** to a sufficient temperature to cause the lower layer of the lid and the heat-seal material on the container body to soften and fuse together. Alternatively, the tool **100** can be withdrawn and another heat-seal tool (not shown) can then be inserted into the container and heated to heat-seal the skirt to the container body. The heat-seal tool can be somewhat larger in diameter than the shaping tool **100** so as to firmly urge the skirt against the container body to ensure good contact and sealing therebetween.

A further embodiment of the invention is depicted in FIGS. 9A and 9B, showing an alternative form of lid **16'**. The lid **16'** is generally similar to the lid **16** described above, except that the outer score line is omitted and the skirt terminates at a location on the inner surface of the container body **12** (e.g., where the outer score line would be located in the prior embodiment), rather than wrapping over the top edge of the container body. Thus, upon opening, the lower layer **26** severs at the score line **42** and then the upper layer **28** peels from the portion of the lower layer above the score line, which remains adhered to the container body as shown in FIG. 9B. Preferably, a peelable adhesive such as PSA is disposed between the layers in the annular region between the score line **42** and the outer peripheral edge of the lid. The upper and lower layers outside the annular region are laminated together with an adhesive providing a bond with a greater peel strength than the peel force required to separate the layers in the annular region.

Many modifications and other embodiments of the inventions set forth herein will come to mind to one skilled in the art to which these inventions pertain having the benefit of the teachings presented in the foregoing descriptions and the associated drawings. For example, while the lid **16** shown and described above has a circular peripheral shape, the present invention also encompasses lids of other shapes such as oval, rectangular, etc. In this regard, terms used herein such as

“annular”, “radial”, “concentric”, and the like, are intended to apply to all such shapes rather than being restricted to circular lids. Therefore, it is to be understood that the inventions are not to be limited to the specific embodiments disclosed and that modifications and other embodiments are intended to be included within the

5 scope of the appended claims. Although specific terms are employed herein, they are used in a generic and descriptive sense only and not for purposes of limitation.

The embodiment of the invention in which an exclusive property or privilege is claimed are defined as follows:

1. A lid for sealing a container, the lid comprising:
  - 5 a flexible laminate comprising an upper layer and a lower layer, a pair of radially spaced concentric lines of weakness each comprising a closed loop being formed in the laminate, an outer one of the lines of weakness being formed in the upper layer and an inner one of the lines of weakness being formed in the lower layer, wherein the upper and lower layers in an annular  
10 region between the lines of weakness are readily separated by exerting a peel force on the upper layer, and wherein the upper and lower layers outside the annular region are laminated together with an adhesive providing a bond with a greater peel strength than the peel force required to separate the layers in the annular region; and  
15 a tab formed as an integral portion of the upper layer, wherein the upper layer is cut through the thickness thereof along a generally U-shaped cut line to define the tab, and the tab is free of adhesive such that the tab can be lifted away from the lower layer,  
20 wherein the adhesive outside the annular region comprises a laminating adhesive having a greater peel strength than that of the pressure-sensitive adhesive.
  2. The lid of claim 1, wherein the laminate includes a generally planar center panel that is disk-shaped and a generally cylindrical skirt joined to an  
25 outer periphery of the center panel and extending upward therefrom such that the lower layer of the skirt faces radially outward and the upper layer of the skirt faces radially inward.
  3. The lid of claim 2, wherein the inner line of weakness is located at a  
30 lower position along the skirt and the outer line of weakness is located at an upper position along the skirt.

4. The lid of claim 1, wherein a pressure-sensitive adhesive is disposed between the upper and lower layers in the annular region.
5. The lid of claim 1, wherein the lower layer comprises a heat-sealable polymer film.
6. The lid of claim 1, wherein the upper layer comprises a polymer film.
7. The lid of claim 6, wherein the upper layer further comprises an aluminum foil.
8. A lid for sealing a container, the lid comprising:  
a disk-shaped flexible laminate comprising an upper layer and a lower layer, the laminate having an outer peripheral edge, a line of weakness comprising a closed loop being formed in the lower layer spaced radially inward of the outer peripheral edge, wherein the upper and lower layers in an annular region between the line of weakness and the outer peripheral edge are readily separated by exerting a peel force on the upper layer, and wherein the upper and lower layers outside the annular region are laminated together with an adhesive providing a bond with a greater peel strength than the peel force required to separate the layers in the annular region; and  
a tab formed as an integral portion of the upper layer of the lid, wherein the upper layer of the central panel is cut through the thickness thereof along a generally U-shaped cut line to define the tab, and the tab is free of adhesive such that the tab can be lifted away from the lower layer of the lid,  
wherein the adhesive outside the annular region comprises a laminating adhesive.
9. A container comprising:  
a container body comprising a side wall having a top edge encircling an opening of the container body, the side wall having an inner surface;  
a lid formed of a flexible laminate comprising an upper layer and a lower

layer, the lid comprising a central panel that is generally disk-shaped and a generally cylindrical skirt joined to an outer periphery of the central panel and extending upwardly therefrom such that the lower layer of the skirt faces radially outwardly, the skirt being bonded to the inner surface of the container body, an outer line of weakness being formed in the upper layer of the skirt and an inner line of weakness being formed in the lower layer of the skirt at a position spaced below the outer line of weakness, wherein the upper and lower layers in an annular region of the skirt between the lines of weakness are readily separated by exerting a peel force on the upper layer, and wherein the upper and lower layers outside the annular region are laminated together with an adhesive providing a bond with a greater peel strength than the peel force required to separate the layers in the annular region; and

a tab formed as an integral portion of the upper layer of the lid, wherein the upper layer of the central panel is cut through the thickness thereof along a generally U-shaped cut line to define the tab, and the tab is free of adhesive such that the tab can be lifted away from the lower layer of the lid,

wherein the adhesive outside the annular region comprises a laminating adhesive.

10. The container of claim 9, wherein the lower layer of the skirt is bonded to the inner surface of the container body such that a peel force required for peeling the skirt from the inner surface of the container body exceeds the peel force required for peeling the upper layer from the lower layer in the annular region of the skirt.

11. The container of claim 9, wherein the adhesive outside the annular region bonds the upper and lower layers together such that a peel force required for peeling the layers apart outside the annular region exceeds the peel force required for peeling the skirt from the inner surface of the container.

12. The container of claim 9, wherein a portion of the skirt below the inner line of weakness is bonded to the inner surface of the container.

13. The container of claim 9, wherein the tab is free of adhesive such that the tab can be lifted away from the lower layer.
14. The container of claim 9, wherein the lower layer of the lid comprises a  
5 heat-sealable polymer film.
15. The container of claim 9, wherein the upper layer of the lid comprises a polymer film.
- 10 16. The container of claim 9, wherein a pressure-sensitive adhesive is disposed between the upper and lower layers in the annular region.

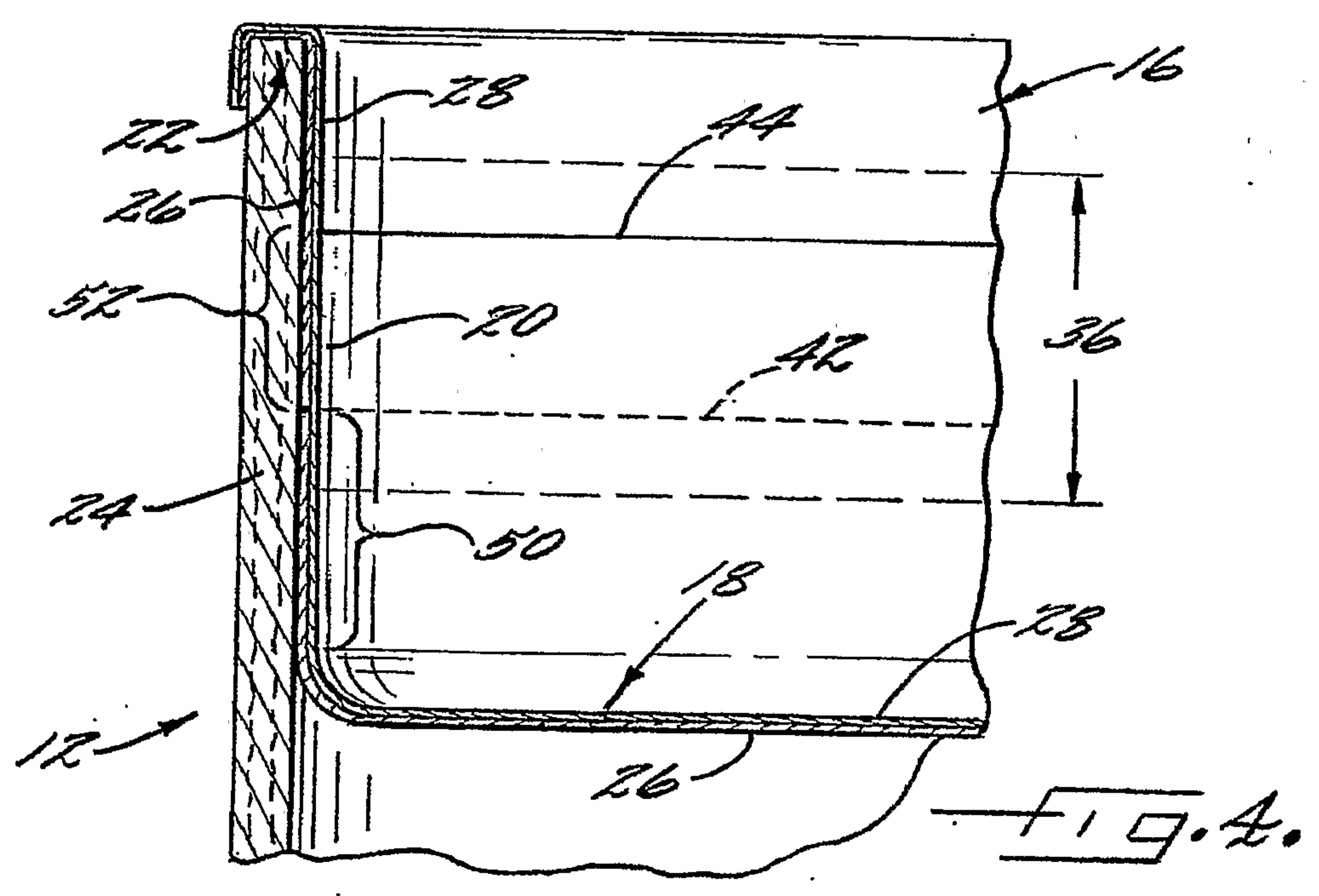
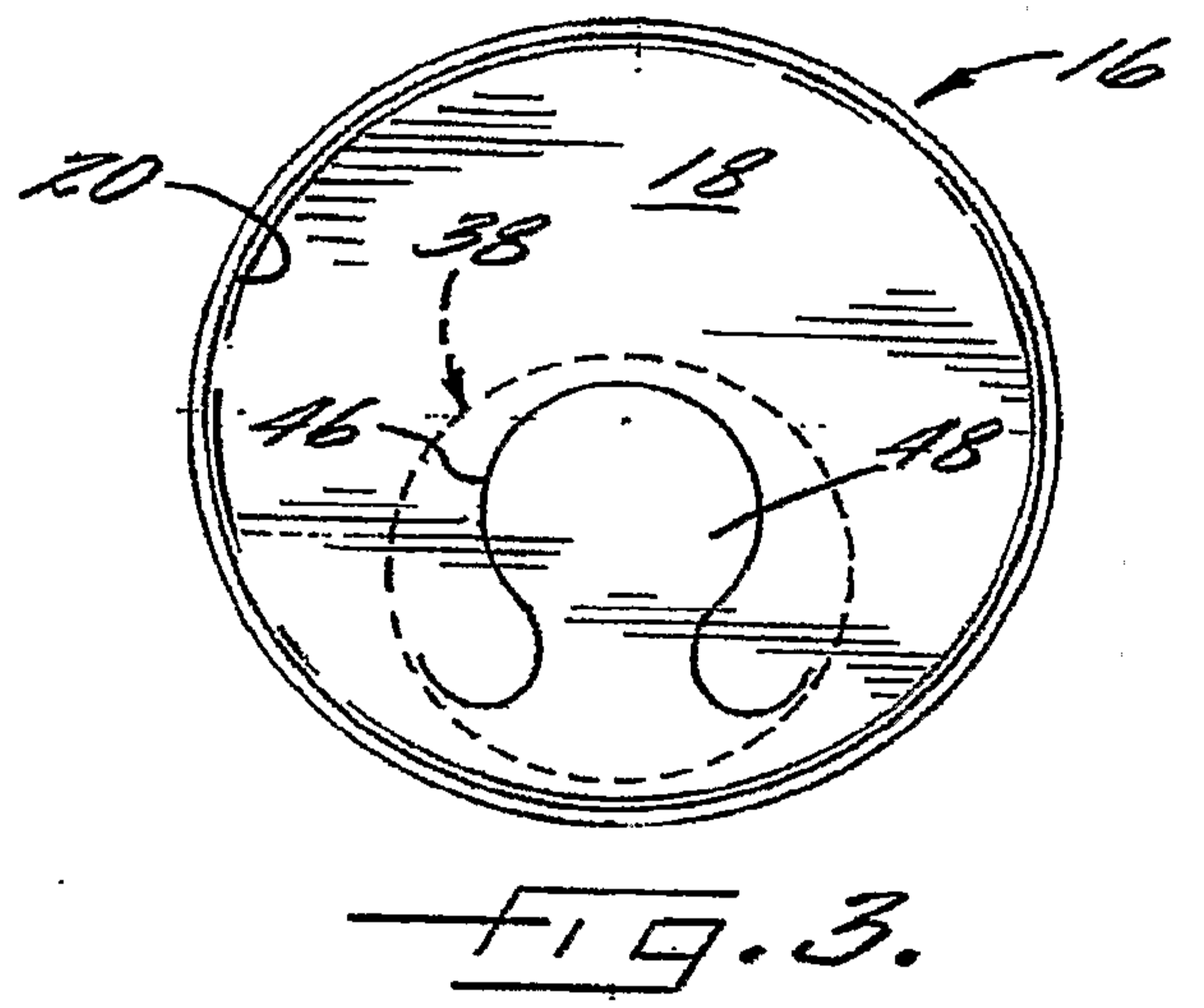
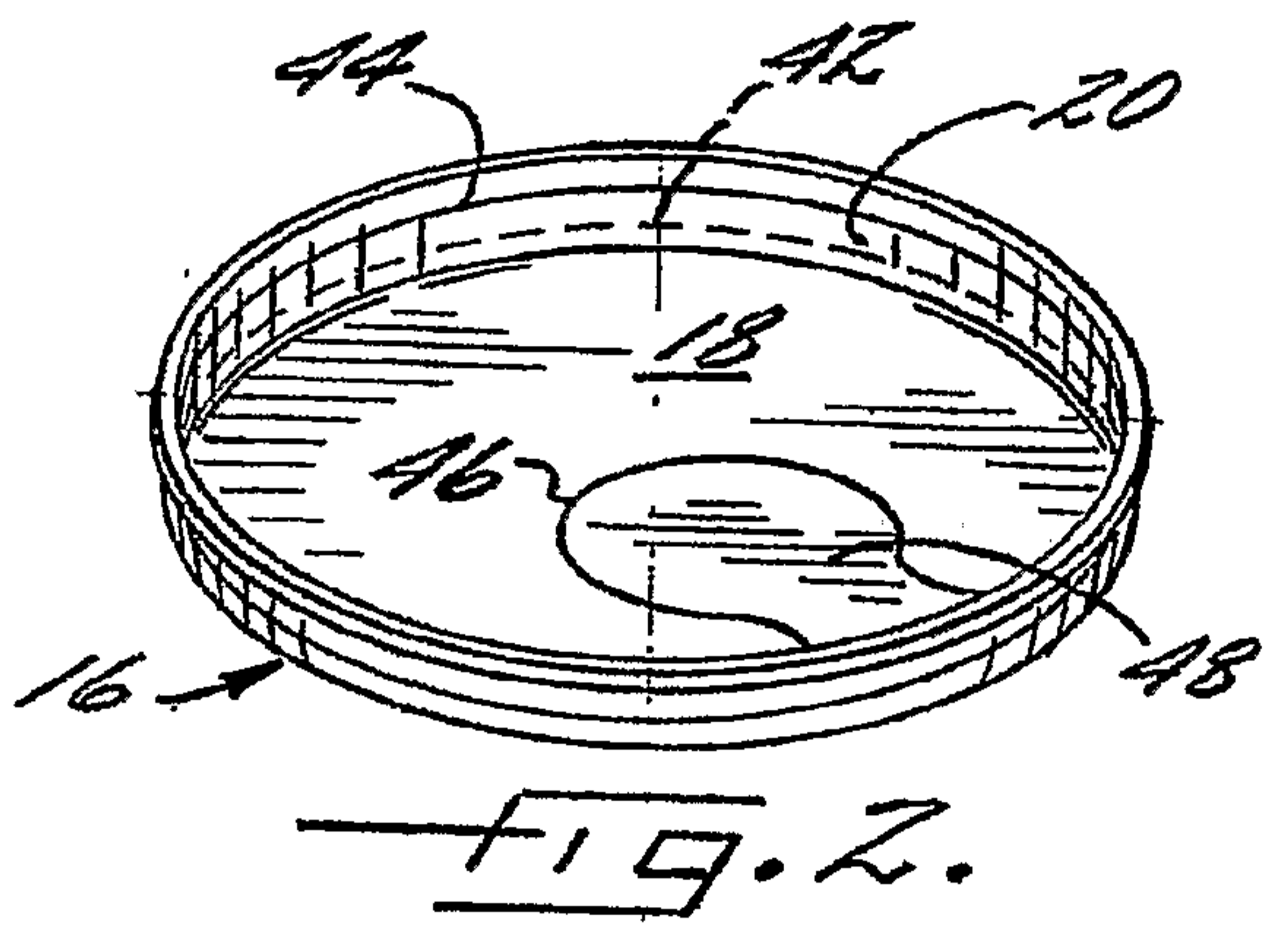
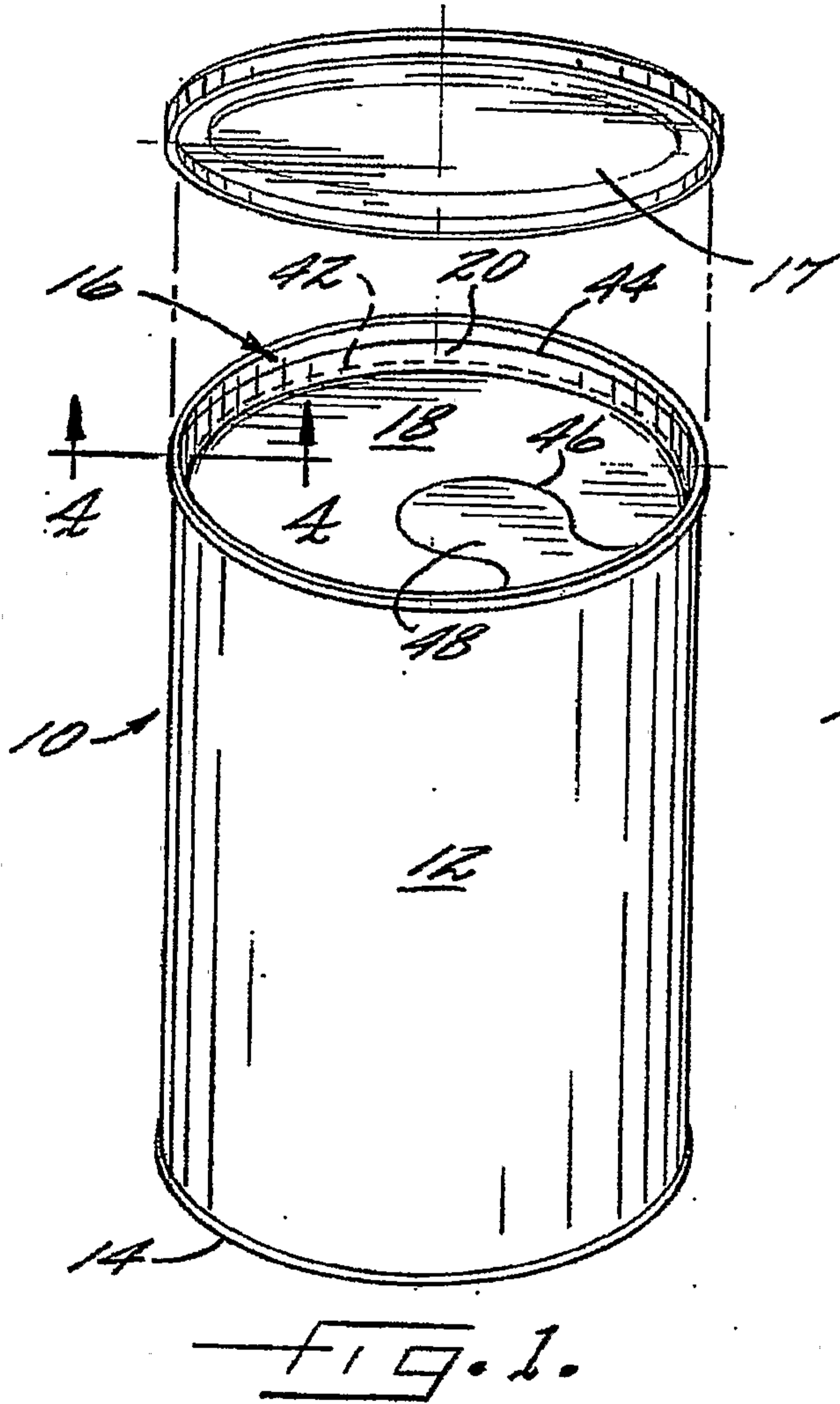



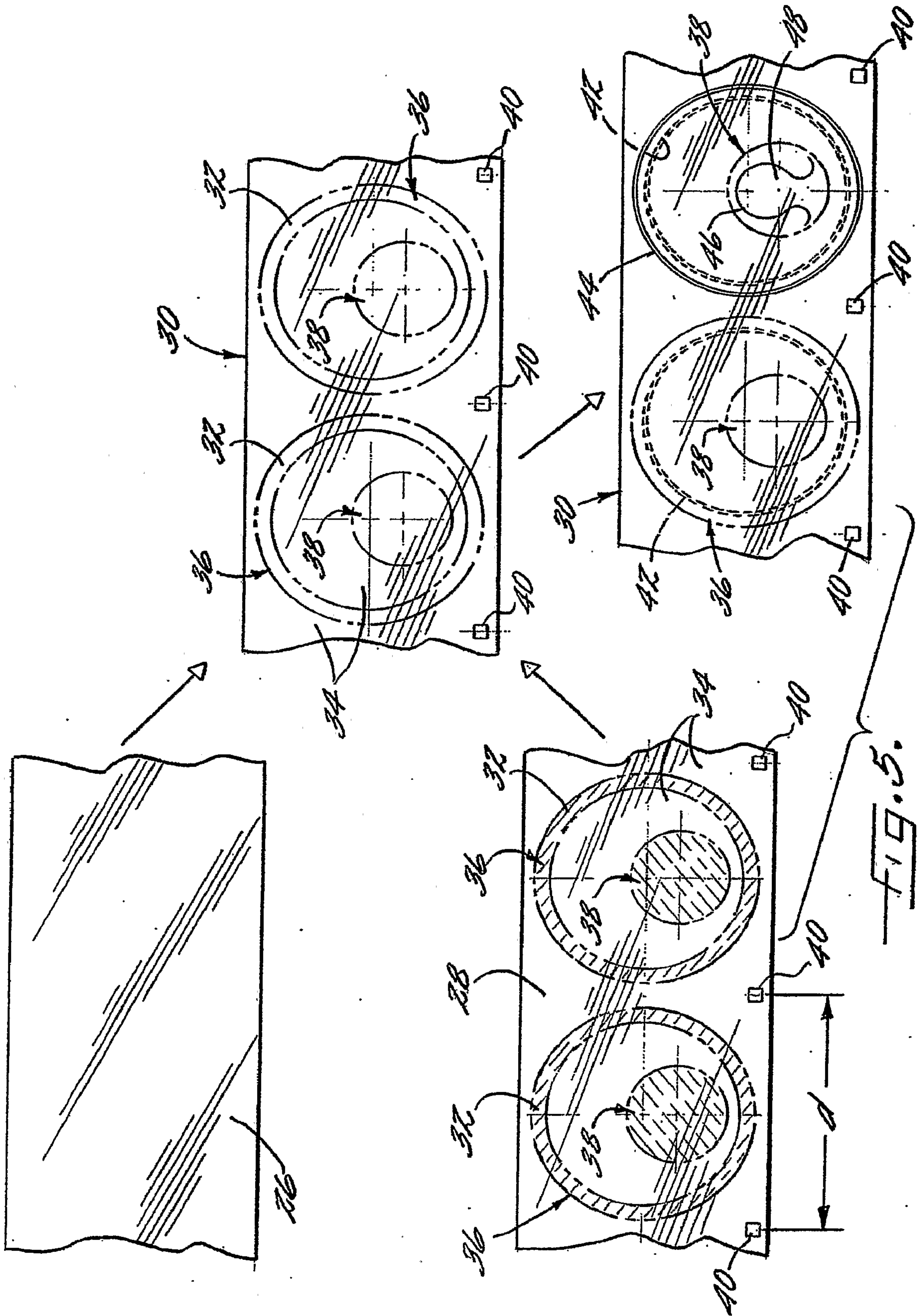

FIG. 5.

