

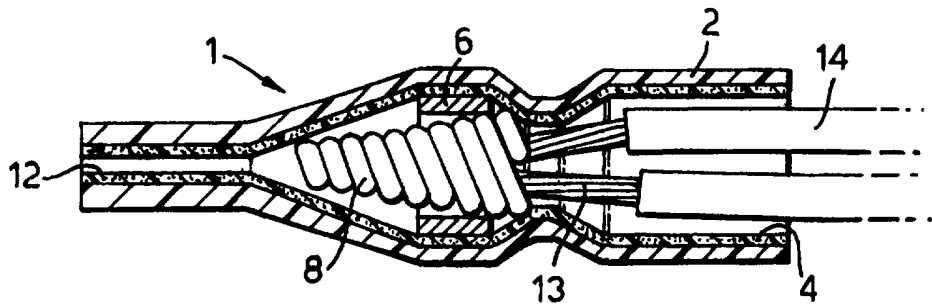

INTERNATIONAL APPLICATION PUBLISHED UNDER THE PATENT COOPERATION TREATY (PCT)

(51) International Patent Classification ⁶ : H01R 4/72, 43/02	A1	(11) International Publication Number: WO 97/23924 (43) International Publication Date: 3 July 1997 (03.07.97)
<p>(21) International Application Number: PCT/GB96/03158</p> <p>(22) International Filing Date: 19 December 1996 (19.12.96)</p> <p>(30) Priority Data: 9526120.2 21 December 1995 (21.12.95) GB</p> <p>(71) Applicant (for all designated States except MG US): RAYCHEM S.A. [FR/FR]; 2, boulevard du Moulin-à-Vent, F-95800 Cergy-Saint-Christophe (FR).</p> <p>(71) Applicant (for MG only): RAYCHEM LIMITED [GB/GB]; IPLD, Faraday Road, Dorcan, Swindon, Wiltshire SN3 5HH (GB).</p> <p>(72) Inventors; and (75) Inventors/Applicants (for US only): BLUTEAU, Dominique [FR/FR]; 5, allée de Gascogne, F-95310 Saint-Ouen-l'Aumône (FR). COLTIN, Thierry [FR/FR]; 24, rue de Puiseux, F-95520 Osny (FR). BRIENS, Sylvain [FR/FR]; 9, rue Louis-Delamarre, F-95230 Soisy-sous-Montmorency (FR). DELAMOTTE, Jean, Christian [FR/FR]; 1, ruelle de Monts, F-60119 Henonville (FR).</p> <p>(74) Agents: JONES, David, Colin et al.; Raychem Limited, IPLD, Faraday Road, Dorcan, Swindon, Wiltshire SN3 5HH (GB).</p>	<p>(81) Designated States: JP, KR, MG, US, European patent (AT, BE, CH, DE, DK, ES, FI, FR, GB, GR, IE, IT, LU, MC, NL, PT, SE).</p> <p>Published With international search report.</p>	

(54) Title: ELECTRICAL CONNECTOR



(57) Abstract

An electrical connector (1) comprises a heat shrinkable sleeve (2) and a co-extruded adhesive liner (4). A tapering metal coil (8) and a ring of solder (6) are contained within the sleeve (2). Stripped electrical conductors (13) are inserted into the connector (1) and temporarily retained by twisting them into the coil (8). Heat is applied by means of an induction coil so that a soldered joint can be made between the conductors (13) before any interference can occur by melting of the adhesive (4) to form an environmental seal.

FOR THE PURPOSES OF INFORMATION ONLY

Codes used to identify States party to the PCT on the front pages of pamphlets publishing international applications under the PCT.

AM	Armenia	GB	United Kingdom	MW	Malawi
AT	Austria	GE	Georgia	MX	Mexico
AU	Australia	GN	Guinea	NE	Niger
BB	Barbados	GR	Greece	NL	Netherlands
BE	Belgium	HU	Hungary	NO	Norway
BF	Burkina Faso	IE	Ireland	NZ	New Zealand
BG	Bulgaria	IT	Italy	PL	Poland
BJ	Benin	JP	Japan	PT	Portugal
BR	Brazil	KE	Kenya	RO	Romania
BY	Belarus	KG	Kyrgystan	RU	Russian Federation
CA	Canada	KP	Democratic People's Republic of Korea	SD	Sudan
CF	Central African Republic	KR	Republic of Korea	SE	Sweden
CG	Congo	KZ	Kazakhstan	SG	Singapore
CH	Switzerland	LI	Liechtenstein	SI	Slovenia
CI	Côte d'Ivoire	LK	Sri Lanka	SK	Slovakia
CM	Cameroon	LR	Liberia	SN	Senegal
CN	China	LT	Lithuania	SZ	Swaziland
CS	Czechoslovakia	LU	Luxembourg	TD	Chad
CZ	Czech Republic	LV	Latvia	TG	Togo
DE	Germany	MC	Monaco	TJ	Tajikistan
DK	Denmark	MD	Republic of Moldova	TT	Trinidad and Tobago
EE	Estonia	MG	Madagascar	UA	Ukraine
ES	Spain	ML	Mali	UG	Uganda
FI	Finland	MN	Mongolia	US	United States of America
FR	France	MR	Mauritania	UZ	Uzbekistan
GA	Gabon			VN	Viet Nam

ELECTRICAL CONNECTOR

This invention relates to an electrical connector and to a method of making an electrical connection. The connector comprises a heat-recoverable polymeric tubular sleeve that contains a quantity of solder for making a permanent electrical connection between at least two electrical conductors, at least one of which may be an elongate insulated wire that has insulation removed from a portion thereof, and material for sealing the electrical connection against ingress of moisture or other contaminants.

Connectors of this general type have been known for many years, and are available from Raychem under its trademark SOLDERSLEEVE. One kind of SOLDERSLEEVE connector has solder in the shape of a ring centrally contained within a heat-recoverable cylindrical polymeric sleeve that is open at each end. An annular insert of fusible material may also be provided towards each end of the sleeve. Application of heat to this connector causes the sleeve to shrink and the solder to melt so as to connect the stripped ends of elongate conductors introduced into respective ends of the sleeve. The fusible inserts melt and flow around the respective conductors to form an environmental, eg moisture, seal therewith, and to retain the solder in place. Such connectors have found widespread acceptance in many markets.

Another form of connector of the general type discussed above is disclosed in European Patent Application Publication No. 0536240, in which a bundle of wires is inserted into one end of a heat shrinkable polymeric sleeve, and temporarily connected together in a tapering metal connecting element. The connecting element is retained within a ring of solder within the sleeve, whose other end is closed by a spherical plug of sealing material. A ring of sealant material is retained within the sleeve adjacent its open end for sealing around the wires on heat recovery of the sleeve. A modification of this general type of connector is disclosed in European Patent Application Publication No. 0615661, which provides for a wire to be connected to the outer conductor of a coaxial cable partway along its length.

WO 93/20596 also discloses a connector comprising a tapering metal connecting element surrounded by a solder ring, in turn surrounded by a heat-shrinkable sleeve. Electrical connection of inserted conductors is made by application of both induction heating and hot air or infra red heating. Sealant material is provided in the form of a ring spaced longitudinally from the connecting element and solder.

WO 94/09531 discloses an electrical connector comprising a tapering metal connecting element surrounded by a heat shrinkable sleeve coated on its inner surface with hot melt adhesive. Electrical connection of inserted conductors is made simply by twisting them into the connecting element, without the use of solder. Heating is achieved by infra red heaters, hot air guns, or naked flames.

US Patent No. 4206786 discloses a connector for forming an in-line splice between two wires in which a heat recoverable sleeve encloses a shorter tubular fusible member which retains a spherical quantity of solder longitudinally centrally thereof.

A disadvantage of each of these connectors lies in the number of components required and thus the time taken to effect their assembly, and the resulting cost of making the connector.

US Patent No. 4883925 discloses a sealed solder connector for forming an in-line splice, that comprises a heat recoverable plastic tubing containing a co-extensive temperature controlled adhesive film and that retains a ring of solder longitudinally centrally thereof. US Patent 5137478 discloses a connector comprising a heat recoverable plastic tubing containing a co-extensive adhesive coating that is recovered at one end on to an electrical terminal member of semi-circular shape coated with a low temperature solder. A wire is inserted into the open end of the sleeve, located over the soldered terminal and heat is applied to the connector to make the solder connection between the wire and the terminal, recover the sleeve into conformity with the wire, and to melt the adhesive to seal the sleeve. Each of these disclosures envisages a torch as the heat source. Whilst a torch,

such as a butane gas torch, is widely used for installation of this general kind of connector, it does introduce a difficulty where, as in US Patent Nos. 4206786, 4883925 and 5137478, the solder is contained within an outer layer of adhesive. The problem is that the outer adhesive layer can melt before the solder melts, or at least before the soldered connection has been fully formed, so that the presence of the adhesive can interfere with, and in extreme cases prevent, the formation of a good solder bond between the conductors. This difficulty is exacerbated if at least one of the conductors is of stranded configuration.

It is one object of the present invention to provide a connector and connecting method that overcome, or at least alleviate, the above-mentioned difficulties associated with known connectors.

In accordance with a first aspect of the present invention, there is provided an electrical connector for electrically connecting together at least two electrical conductors, the connector comprising:

- (a) a heat recoverable polymeric tubular sleeve that has a heat-flowable sealant layer extending over substantially the entire inner surface thereof, the sleeve being open at at least one end to receive at least one of the electrical conductors, and
- (b) a quantity of solder and a metal connecting element retained within the sleeve and arranged to receive the electrical conductors to be connected together.

Advantageously, the sleeve and sealant are coextruded and cut to length, thus simplifying the manufacturing process and reducing its cost in comparison with connectors having one or more discrete portions of sealant.

The heat flowable sealant may comprise a hot melt adhesive.

- 4 -

The connector of the invention is particularly advantageous when, upon installation, heat is applied to it by means of electric induction from a surrounding coil. The induced currents, taking advantage of the skin effect, directly and preferentially heat the metal connecting element and the solder, and then subsequently thermal transfer therefrom heats the sealant and the sleeve. Thus, the electrical solder connection can be made before any substantial interference can occur from the flowing sealant, unlike the situation that would occur if torch heating were to be used.

Heating of a connector of the general type disclosed in the above-mentioned publications using induction heating is known, and is disclosed for example in European Patent Application Publication NO. 0634059. However the use of induction heating requires the provision of electricity in order to produce an a.c. field. The use of direct heating eg by a torch only requires the provision of a fuel such as liquefied petroleum gases. Pressurised cylinders and canisters of liquefied petroleum gases are readily available in portable form. The skilled person would therefore not routinely use induction heating in place of direct heating provided by the combustion of fuel.

Thus, in accordance with a second aspect of the present invention, there is provided a method of electrically connecting together at least two electrical conductors by means of an electrical connector comprising a heat-recoverable polymeric tubular sleeve that has a layer of heat-flowable sealant material extending over substantially the entire inner surface thereof, the sleeve having at least one open end, and wherein the sleeve contains a quantity of solder, the method comprising, introducing at least one electrical conductor into the open end of the sleeve so as to be adjacent at least one other electrical conductor and the solder within the sleeve, and applying an alternating high frequency magnetic field to the solder and/or conductors thereby to generate heat so as to melt the solder to form the electrical connection between the conductors and subsequently to melt the sealant to cause it to flow around the connected conductors and to recover the sleeve so as to enclose the sealant and the connected conductors.

- 5 -

Advantageously, the connector is used in the method aspect of the present invention, is in accordance with the first aspect of this invention.

Thermal transfer to heat the non-metallic components of the connector, namely the sleeve and the heat flowable sealant, can be significantly improved by employing a susceptor around these components longitudinally beyond the metal components. The same, or a different, induction coil can be used to induce eddy currents in the metal susceptor, and the infrared radiation that is then generated is directed on to the sleeve and sealant.

The connector contains a quantity of solder for forming a permanent solder connection between the or each conductor and the terminal shank. The connector also contains a quantity of heat flowable sealant material for sealing the connection of the terminal against ingress of moisture or other contaminant. The solder and/or the sealant may be provided in the form of a ring, which may be retained by partial local recovery of the sleeve. Advantageously, however, the sealant, provided as a layer extending over substantially the entire inner surface of the sleeve, may be co-extruded therewith.

As indicated above the solder may be provided as a ring surrounding the connecting element, and this is suitable when in a suitable way, the connecting element is open for the solder to flow therethrough when molten to effect the electrical connection. The connecting element is preferably constructed so as to provide a temporary connection between the electrical conductors before the solder connection is made. Thus the connecting element preferably has a retaining portion for retaining a conductor which decreases in the direction of insertion of a conductor into the retaining portion. The connecting element preferably has at least one conductor engaging portion extending into the retaining portion, preferably at least two spaced apart on the surface of the retaining portion in contact with the electrical conductor. Advantageously, the connecting element comprises a tapered metal coil as disclosed in European Patent Application No. 0536240, the entire contents of which are enclosed herein by this reference. Such a connector conveniently allows a temporary

electrical connection to be made, for example for test purposes, before the final permanent solder connection is formed. Where the connecting element is a tapered coil, the turns of the coil provide the spaced apart engaging means. The connecting element is open to allow molten solder to flow through it as a consequence of the presence of the gaps between successive turns of the coil. Alternatively the connecting element may be stamped from sheet metal with apertures to allow molten solder to flow through the connecting element into the retaining portions with tangs of sheet metal projecting into the retaining portion to assist in providing temporary connection to an electrical conductor.

The connector, in one embodiment, may be arranged to form a butt splice at the ends of two or more conductors inserted through one end of the sleeve. The closing and sealing of the other end of the sleeve can conveniently and relatively cheaply be effected simply by heating that end of the sleeve to cause the sealant to soften and flow and the sleeve to recover locally. This heating may be carried out during the manufacture of the connector, and may then be done by the application of hot air or infrared radiation, or it may be carried out at the time of making the electrical connection between the conductors. In the former case, the sleeve may be only substantially closed, that is to say a narrow opening may be left at that end of the sleeve to allow for an initial escape of air from the sleeve at the subsequent time of installing the connector. With this connector, therefore, no discrete sealing component, such as the spherical plug of the connector disclosed in European Patent Application Publication No. 0536240 is required, again making the manufacture of the connector simpler, quicker and cheaper.

In an alternative embodiment, the connector may be arranged to form an in-line connection, and in this case, the connection element may conveniently take a form as disclosed in International Patent Application No. PCT/GB95/01774 or in British Patent Application No. 9514412.7, the entire contents of which are included herein by this reference.

In a still further embodiment, the connector may be arranged to provide a branch connection as disclosed in European Patent Application Publication No. 0615661, the entire disclosure of which is included herein by this reference.

In each of these embodiments, some or all the electrical conductors may be elongate conductors, either solid or stranded, and will usually be insulated apart from the portions to be connected. It is also envisaged, however, that one of the conductors, for example, a single conductor introduced into one end of the sleeve, may comprise a terminal and may be pre-installed in the sleeve during manufacture of the sleeve and be suitable, for example, for connection as disclosed, for example, in International Patent Application Publication No. WO/95/17024, the entire contents of which are included herein by this reference. The terminal may have a first portion projecting beyond the end of the sleeve for connection to other electrical equipment, for connection into an electrical circuit by a push fit or other mechanical connection, by solder, or by any other suitable means. The other terminal portion, or shank, may be retained within the sleeve for receiving or otherwise co-operating with a conductor introduced into the other end of the sleeve. The terminal shank may have the solder of the connector disposed thereon or therein. Furthermore, the connecting element of the connector may be located on or in the shank, or it may comprise the shank.

It is particularly preferred to have the solder element surrounding the connecting element and for the connecting element to be open for the solder to flow therethrough when molten to effect electrical connection.

Embodiments of connectors and connection methods, each in accordance with the present invention, will now be described, by way of example, with reference to the accompanying drawings, in which :

Figure 1a shows a section through a butt splice connector,

Figure 1b shows a section through the butt splice connector showing two conductors in position in the connector before the solder connection is made,

Figure 2 shows a section through a branch connection,

Figure 3 shows a section through an in-line connector, and

Figure 4 shows a section through a connector in which one of the electrical conductors is a terminal.

Referring to Figures 1a and 1b, the connector 1 comprises a heat recoverable polymeric generally-cylindrical sleeve 2 that has a co-extruded liner 4 of hot melt adhesive over its entire inner surface. The lined sleeve 2 contains a ring of solder 6 partway along, which itself surrounds a tapered metal coil of wire 8.

The sleeve 2 is partially recovered in the region of the solder 6 and coil 8 in order to retain these components in place. The sleeve 2 is completely open at its end 10 facing the larger opening of the coil 8, and is almost completely recovered at its other end beyond the smaller opening of the coil 8, to leave a narrow opening 12 extending therebeyond. This partial recovery of the lined sleeve 2, carried out as a final stage in its manufacture, can conveniently be done by directing controlled heat from a hot air gun locally on to the relevant portions of the sleeve.

In operation, two or more elongate conductors (not shown in Figure 1a) to be connected together, with insulation stripped from their ends, are inserted into the open end 10 of the sleeve 2 so as to engage the coil 8. The connector 1 is then rotated with respect to the conductors to form a mechanical interengagement therewith and to form a temporary electrical connection therebetween. The electrical circuit of which the conductors form a part may thus be tested for its continuity. Figure 1b shows this stage of the installation with ends of two stranded conductors 13, from which insulation 14 has been removed, in temporary mechanical engagement with the coil 8.

- 9 -

The connector 1 is finally fully installed by induction heating. To this end, power is applied to an induction coil (not shown) that is disposed around the connector 1. The solder 6 is thus heated directly, and melts and flows between the turns of the coil 8 and on to the exposed conductors therein, which conductors may themselves, as well as the coil 8, also be heated by the induced current. Thermal transfer from the metal components then heats the adhesive 4 and the sleeve 2, causing the sleeve 2 to shrink into close conformity around the conductors in its end 10 and to be sealed against ingress of moisture by the flowing of the adhesive 4. At the other end of the connector 1, the passageway 12 also becomes sealed. It will be appreciated that the use of induction heating enables the soldered electrical connection to be properly formed before any significant melting of the adhesive 4 takes place, which could otherwise interfere with the formation of a good bond between the conductors.

Figure 2 exemplifies the invention in the formation of a branch connection. A connector 20 comprises an outer heat shrinkable polymeric sleeve 22 and a co-extruded inner adhesive layer 24. The sleeve 22 is partially recovered halfway along its length to retain a ring of solder 26 around a frusto-conical coil of wire 28 that forms a metal connecting element.

The connector 20 is disposed over a coaxial cable 30 with the solder 26 and coil 28 located over a centre-stripped portion 32 of the outer earth braid thereof. A branch earthing cable 34 extends into the connector 20 from one end thereof to dispose its stripped end within the coil 28. Permanent electrical connection between the conductors 30 and 34 and sealing thereof is carried out by induction heating substantially as described with reference to Figure 1.

Referring to Figure 3, an in-line splice is made between two conductors 40, 42 by means of a connector 44 that has an outer polymeric heat-shrinkable sleeve 46 with a coterminous hot melt adhesive liner 48. The connecting element comprises a metal sheet that has been folded several times so as to define two chambers 50, 52, each defined by

four planar sides that taper inwardly from a respective open end of the sleeve 46. The chambers 50, 52 lie on top of one another with a strip of solder 54 located between them. The sheet is stamped such that the solder 54 overlies internal chamber walls that are apertured to allow, upon installation, molten solder to flow into the chambers 50, 52. External chamber walls are stamped such that tangs 56 project into the chambers 50, 52 such as to permit entry of the conductors 40, 42 but to resist their withdrawal.

In operation, the conductors 40, 42 are inserted into respective chambers 50, 52 and temporarily retained by the tangs 56. An induction coil (not shown) is disposed around the connector 44 and activated so as to heat the solder 54 and chambers 50, 52 and to make the permanent soldered connection between the conductors 40, 42. Finally, thermal transfer from the metal components causes the adhesive 48 to melt and to flow and the sleeve 46 to shrink so as to conform to and seal around the conductors 40, 42.

Referring now to Figure 4 an electrical connector is shown connected to one electrical conductor namely a terminal 60 with an aperture 61 by which it can be connected to an item of electrical equipment. The terminal has a shank 62 bonded by upstanding walls 63. A tapered metal coil 64 is inserted into the shank 62 so as to be gripped by the upstanding walls 63. The coil 64 acts as a connecting element between terminal 60 and a second electrical conductor in the form of a stranded wire conductor 65 surrounded by an insulating jacket 66.

A solder ring 67 surrounds part of coil 64. A sleeve 68 of heat-shrinkable polymeric material surrounds the solder ring and coil 64. A layer of hot melt adhesive extends over the entire inner surface of sleeve 68. As shown in Figure 4 one end of the sleeve has been heated to shrink it so as to hold the sleeve on to the terminal but without melting the solder ring 67.

- 11 -

In order to make a connection between conductor 65 and terminal 61 the conductor 65 is passed into the interior of the connecting member formed by coil 64 until it engages with the coil to form a temporary connection by means of a relative twisting action.

An induction coil (not shown) is used to heat the solder 67 and the coil 64 to cause the solder to melt and flow through the gap between the turns of the coil to make a permanent soldered connection between the conductor 65 and the coil 64.

CLAIMS :

1. An electrical connector for electrically connecting together at least two electrical conductors, the connector comprising :
 - (a) a heat-recoverable polymeric tubular sleeve that has a heat-flowable sealant layer extending over substantially the entire inner surface thereof, the sleeve being open at at least one end to receive at least one of the electrical conductors, and
 - (b) a quantity of solder and a metal connecting element retained within the sleeve and arranged to receive the electrical conductors to be connected together.
2. A connector according to claim 1, wherein the solder and connecting element are longitudinally enclosed one within the other.
3. A connector according to claim 2, wherein the solder surrounds the connecting element and the connecting element is open for the solder to flow therethrough when molten to effect electrical connection.
4. A connector according to any one of the preceding claims, wherein one end of the sleeve is at least substantially closed by recovery thereof and sealed by the flow of the sealant at that end of the sleeve.
5. A connector according to any one of the preceding claims, wherein the solder and connecting element are retained within the sleeve by partial recovery thereof.
6. A connector according to any one of the preceding claims, wherein the connecting element is tapered and is arranged to receive said at least one electrical conductor through the larger end thereof and through an open end of the sleeve.

- 13 -

7. A connector according to claim 6, wherein the connecting element is formed from a strip of wire wound into a helix.
8. A connector according to any one of the preceding claims, wherein the sleeve is open at each end for receiving respective electrical conductors therethrough.
9. A connector according to any one of the preceding claims, wherein one of the electrical conductors comprises a terminal that has a shank at one end thereof, and wherein the shank is retained within one end of the sleeve.
10. A connector according to claim 9, wherein the solder is disposed on or in the shank of the terminal.
11. A connector according to claim 9 or claim 10, wherein the connecting element is located on or in, or comprises, the shank of the terminal.
12. A connector according to any one of the preceding claims, wherein the connecting element and/or the solder is capable of being heated by induction.
13. A connector according to any one of the preceding claims, wherein the sleeve and sealant are co-extruded.
14. A method of electrically connecting together at least two electrical conductors by means of an electrical connector comprising a heat-recoverable polymeric tubular sleeve that has a layer of heat-flowable sealant material extending over substantially the entire inner surface thereof, the sleeve having at least one open end, and wherein the sleeve contains a quantity of solder, the method comprising, introducing at least one electrical conductor into the open end of the sleeve so as to be adjacent at least one other electrical conductor and the solder within the sleeve, and applying an alternating high frequency magnetic field to the solder and/or conductors thereby to

- 14 -

generate heat so as to melt the solder to form the electrical connection between the conductors and subsequently to melt the sealant to cause it to flow around the connected conductors and to recover the sleeve so as to enclose the sealant and the connected conductors.

15. A method according to claim 14, wherein the connector is in accordance with any one of claims 1 to 13.

Fig. 1a.

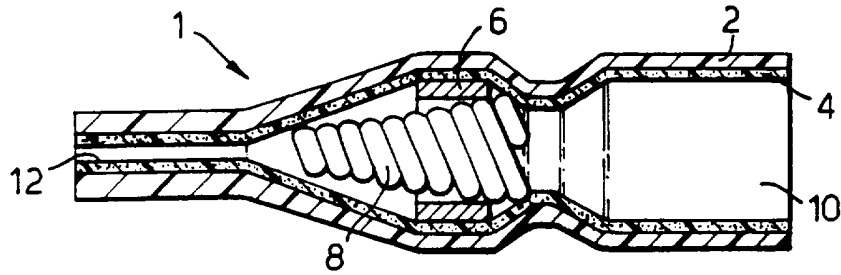

Fig. 1b.

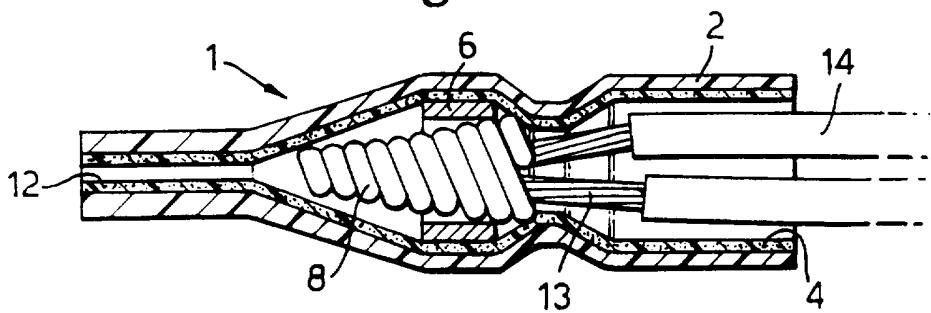

Fig. 2.

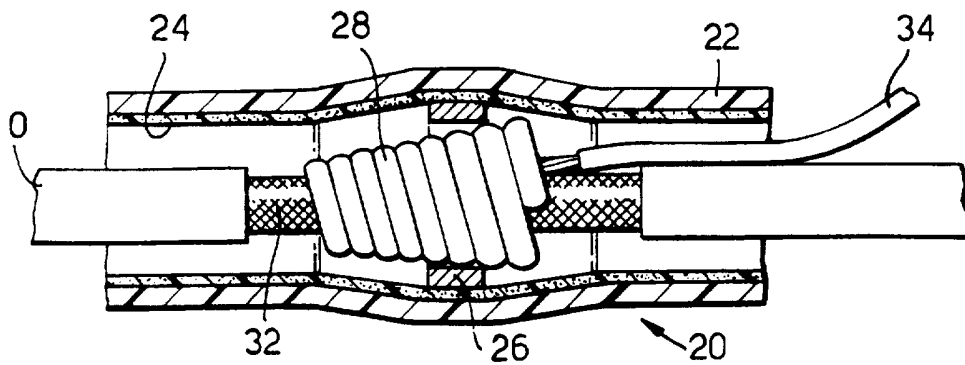

Fig.3.

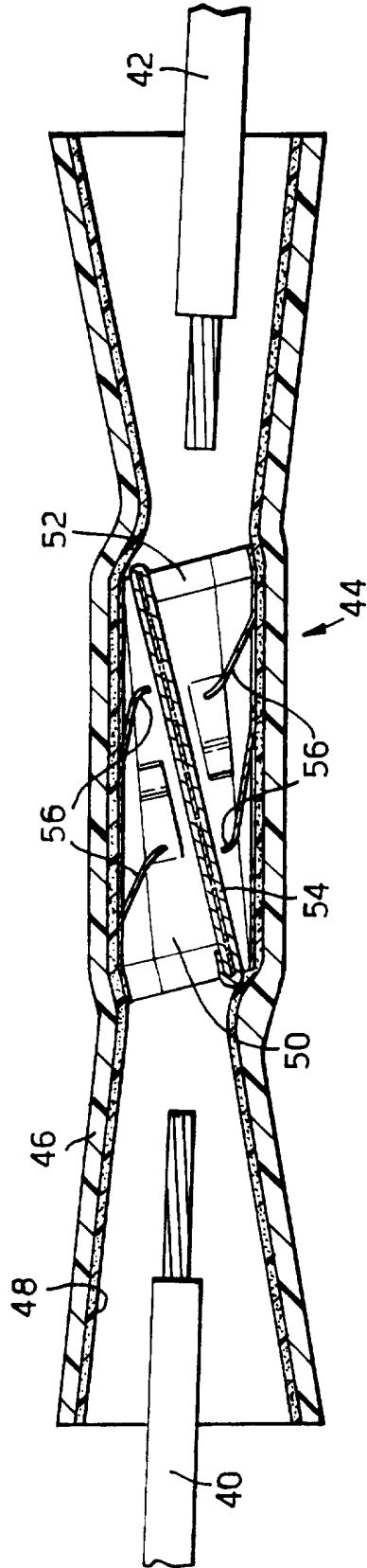
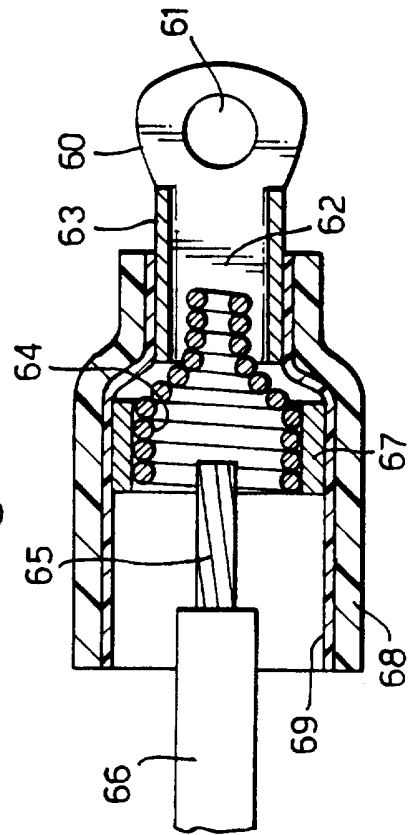

Fig.4.



INTERNATIONAL SEARCH REPORT

International application No.

PCT/CA 96/03158

A. CLASSIFICATION OF SUBJECT MATTER

IPC6: H01R 4/72, H01R 43/02

According to International Patent Classification (IPC) or to both national classification and IPC

B. FIELDS SEARCHED

Minimum documentation searched (classification system followed by classification symbols)

IPC6: H01R

Documentation searched other than minimum documentation to the extent that such documents are included in the fields searched

Electronic data base consulted during the international search (name of data base and, where practicable, search terms used)

C. DOCUMENTS CONSIDERED TO BE RELEVANT

Category*	Citation of document, with indication, where appropriate, of the relevant passages	Relevant to claim No.
X	WO 9316505 A1 (MINNESOTA MINING AND MANUFACTURING COMPANY), 19 August 1993 (19.08.93)	1-2
Y	--	3-15
Y	WO 9320596 A1 (RAYCHEM LIMITED ET AL), 14 October 1993 (14.10.93)	3-8, 12-15
Y	WO 9305546 A1 (RAYCHEM LIMITED ET AL), 18 March 1993 (18.03.93)	9-11
Y	EP 0420480 A2 (AMP INCORPORATED), 3 April 1991 (03.04.91)	14-15

 Further documents are listed in the continuation of Box C. See patent family annex.

* Special categories of cited documents:

- "A" document defining the general state of the art which is not considered to be of particular relevance
- "E" earlier document but published on or after the international filing date
- "I" document which may throw doubts on priority claim(s) or which is cited to establish the publication date of another citation or other special reason (as specified)
- "O" document referring to an oral disclosure, use, exhibition or other means
- "P" document published prior to the international filing date but later than the priority date claimed

"T" later document published after the international filing date or priority date and not in conflict with the application but cited to understand the principle or theory underlying the invention

"X" document of particular relevance: the claimed invention cannot be considered novel or cannot be considered to involve an inventive step when the document is taken alone

"Y" document of particular relevance: the claimed invention cannot be considered to involve an inventive step when the document is combined with one or more other such documents, such combination being obvious to a person skilled in the art

"&" document member of the same patent family

Date of the actual completion of the international search

12 March 1997

Date of mailing of the international search report

16.04.97

Name and mailing address of the ISA/



European Patent Office, P.B. 5818 Patentlaan 2
 NL-2280 HV Rijswijk
 Tel. (+ 31-70) 340-2040, Tx. 31 651 epo nl,
 Fax: (+ 31-70) 340-3016

Authorized officer

Christer Wendenius

INTERNATIONAL SEARCH REPORT

International application No.

PCT/GB 96/03158

C (Continuation). DOCUMENTS CONSIDERED TO BE RELEVANT

Category*	Citation of document, with indication, where appropriate, of the relevant passages	Relevant to claim No.
A	US, A, 5064978 (J.P. SCHOLZ), 12 November 1991 (12.11.91) --	14-15
A	WO, A1, 9409531 (RAYCHEM LTD. ET AL), 28 April 1994 (28.04.94) -- -----	1-13

INTERNATIONAL SEARCH REPORT
Information on patent family members

03/02/97

International application No.
PCT/GB 96/03158

Patent document cited in search report	Publication date	Patent family member(s)	Publication date
WO-A1- 9316505	19/08/93	DE-D,T- 69300485	02/05/96
		EP-A,B- 0626101	30/11/94
		ES-T- 2077480	16/11/95
		HU-A- 70732	30/10/95
		HU-D- 9402345	00/00/00
		JP-T- 7503808	20/04/95
		US-A- 5393932	28/02/95
WO-A1- 9320596	14/10/93	EP-A- 0634059	18/01/95
		JP-T- 7505254	08/06/95
		US-A- 5579575	03/12/96
WO-A1- 9305546	18/03/93	AT-T- 146015	15/12/96
		CA-A- 2100869	08/08/92
		CA-A- 2115447	18/03/93
		DE-D- 69215685	00/00/00
		EP-A- 0570436	24/11/93
		EP-A,B- 0602088	22/06/94
		JP-T- 6505121	09/06/94
		JP-T- 6510161	10/11/94
		US-A- 5397858	14/03/95
		US-A- 5418331	23/05/95
		WO-A- 9214279	20/08/92
EP-A2- 0420480	03/04/91	DE-D,T- 69019908	15/02/96
		JP-A- 3127472	30/05/91
		US-A- 4991288	12/02/91
US-A- 5064978	12/11/91	EP-A,B- 0405561	02/01/91
		JP-A- 3047675	28/02/91
WO-A1- 9409531	28/04/94	AU-A- 5152693	09/05/94
		CA-A- 2144645	28/04/94
		EP-A- 0664055	26/07/95
		JP-T- 8502615	19/03/96
		US-A- 5514836	07/05/96