



(19) **United States**

(12) **Patent Application Publication**
Poscich

(10) **Pub. No.: US 2004/0232658 A1**

(43) **Pub. Date: Nov. 25, 2004**

(54) **INTERFACE FOR ENGAGING A
SNOWBOARD BOOT TO A SNOWBOARD
BINDING**

(75) Inventor: **Douglas V. Poscich**, Hinesburg, VT
(US)

Correspondence Address:
James M. Hanifin, Jr.
Wolf, Greenfield & Sacks, P.C.
600 Atlantic Avenue
Boston, MA 02210 (US)

(73) Assignee: **The Burton Corporation**, Burlington,
VT (US)

(21) Appl. No.: **10/802,403**

(22) Filed: **Mar. 16, 2004**

Related U.S. Application Data

(60) Continuation of application No. 10/151,194, filed on
May 20, 2002, now Pat. No. 6,705,633, which is a
division of application No. 09/990,581, filed on Nov.
21, 2001, now Pat. No. 6,722,688.

Publication Classification

(51) **Int. Cl.⁷ A63C 9/02**
(52) **U.S. Cl. 280/618**

(57) **ABSTRACT**

A snowboard binding system that incorporates the riding
performance of a strap binding with the convenience of a

step-in binding. The binding system includes a binding
interface that is configured to be coupled to a step-in binding
base, while also being configured to secure a snowboard
boot in a manner that provides a rider with the riding
performance of a strap binding. The binding interface may
include one or more straps for securing a boot to a snow-
board. The binding system may be configured so that the
binding base engages regions of the binding interface to
which the straps are attached to provide the feel of a strap
binding. The binding base may include at least three engage-
ment members to engage with corresponding mating fea-
tures on the interface. The binding base may include a pair
of engagement members at both the rear or heel end and the
front or toe end thereof to engage with corresponding mating
features on the interface. The engagement members at the
heel end of the binding base may be configured to move
independently of the engagement members at the toe end of
the binding base to facilitate stepping the interface into and
out of the binding base. The binding may be provided with
a locking arrangement that reduces the likelihood of a false
locking condition between the interface and binding by
prohibiting at least one of the pairs of engagement mem-
bers from becoming locked until each of the pair of engage-
ment members assumes its closed position. The binding may
be provided with a locking arrangement that maintains each
of a pair of engagement members in each of a plurality of
closed positions to secure a corresponding pair of mating
features. The binding interface may have a lower portion
with a X-shape configuration to be mounted below a boot
sole.

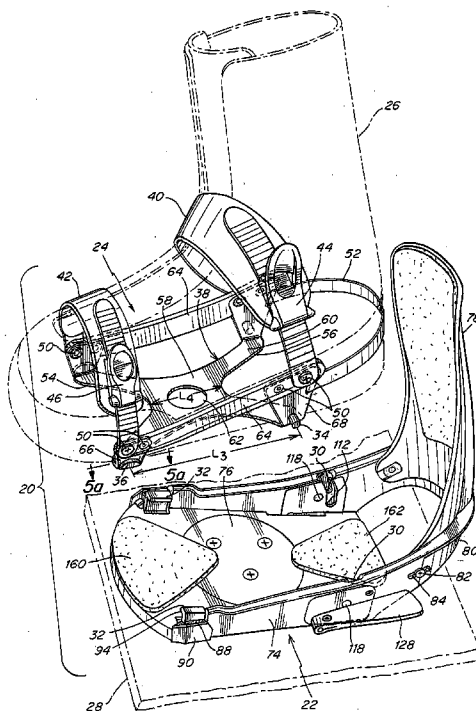

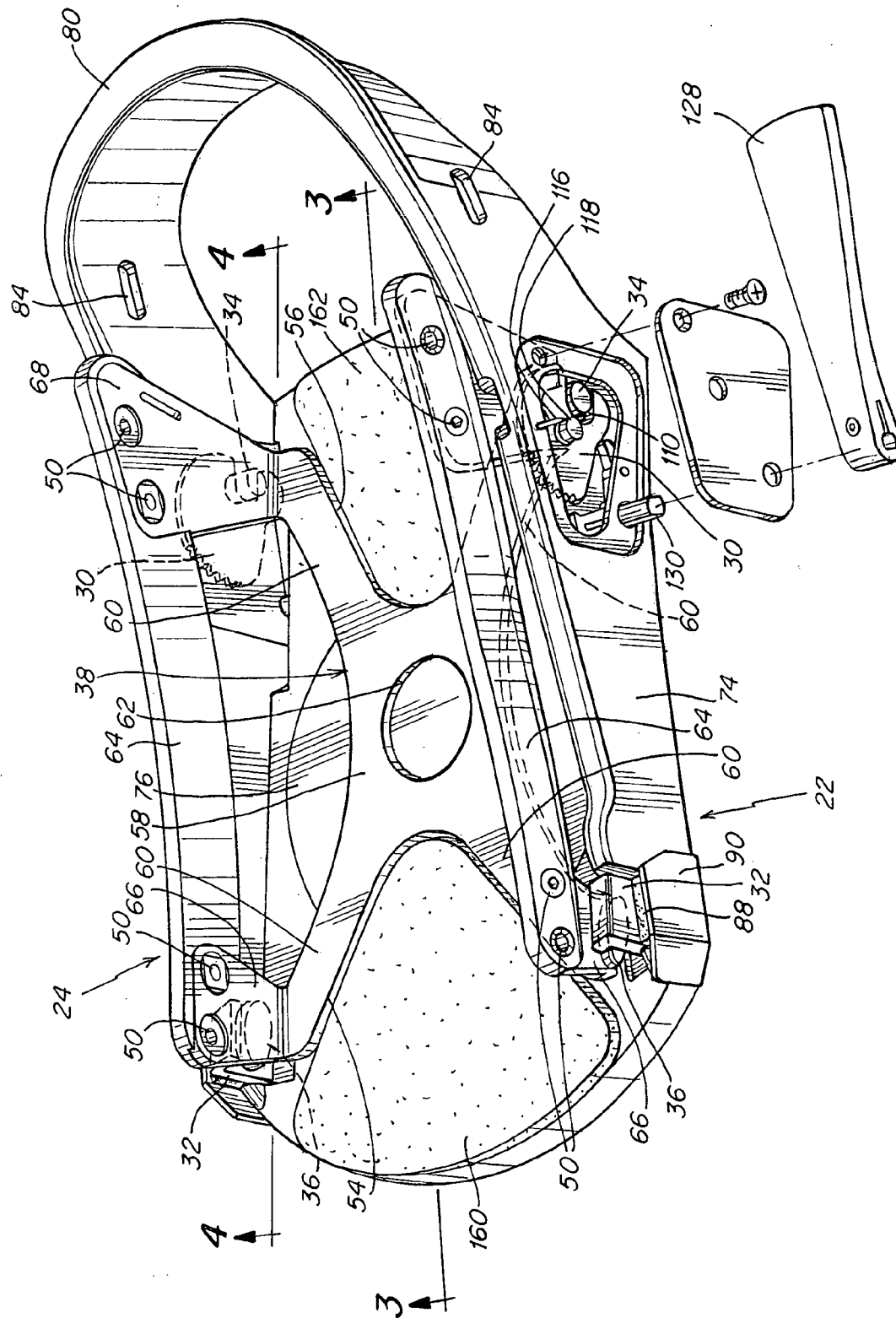

Fig. 2

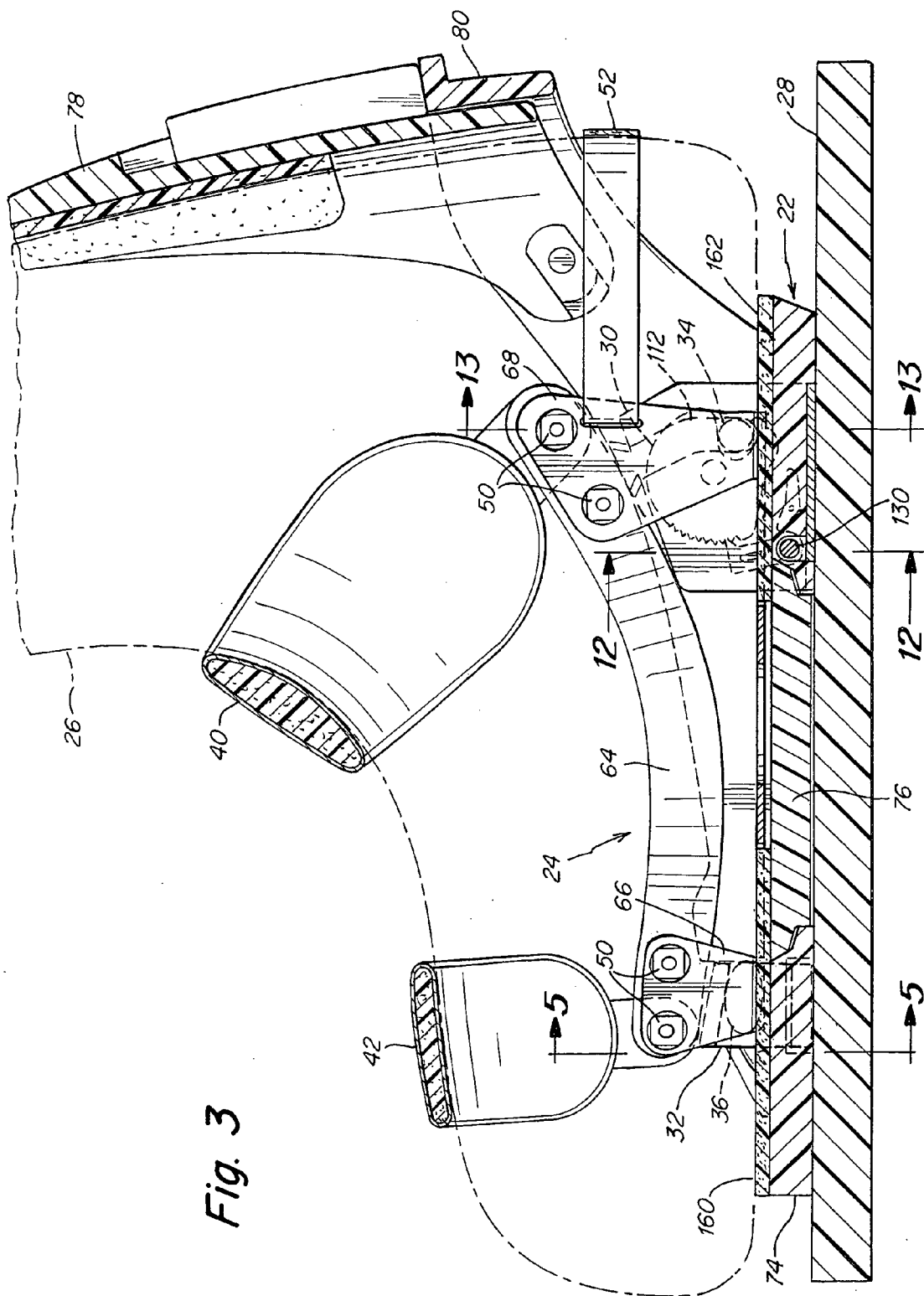

Fig. 3

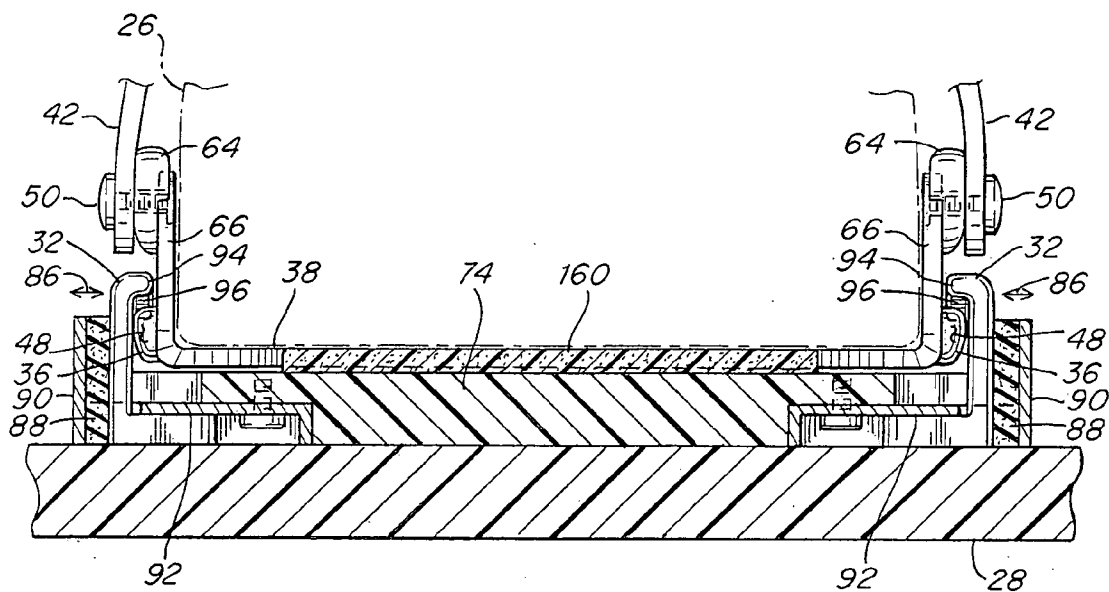

Fig. 5

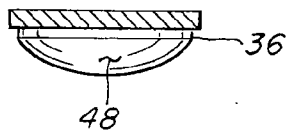

Fig. 5a

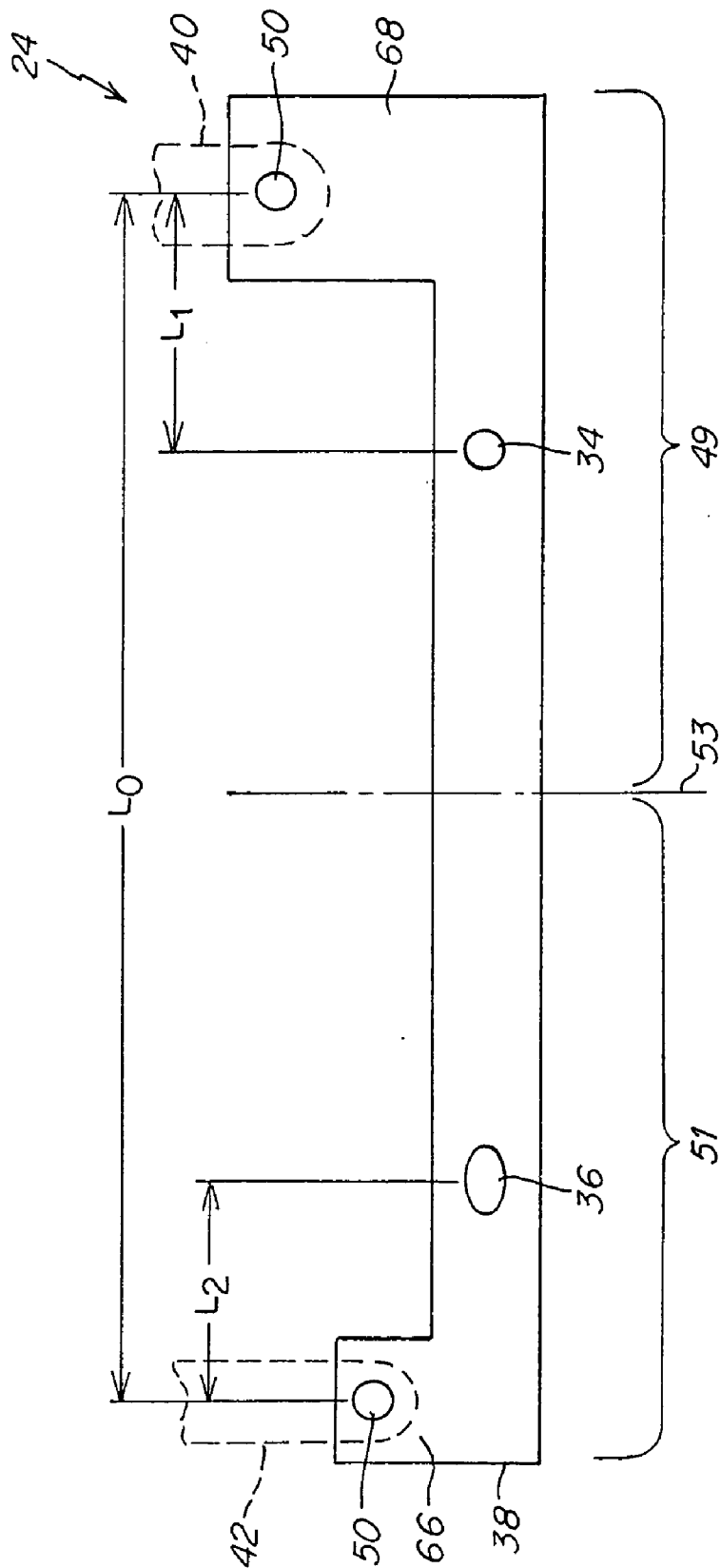

Fig. 6

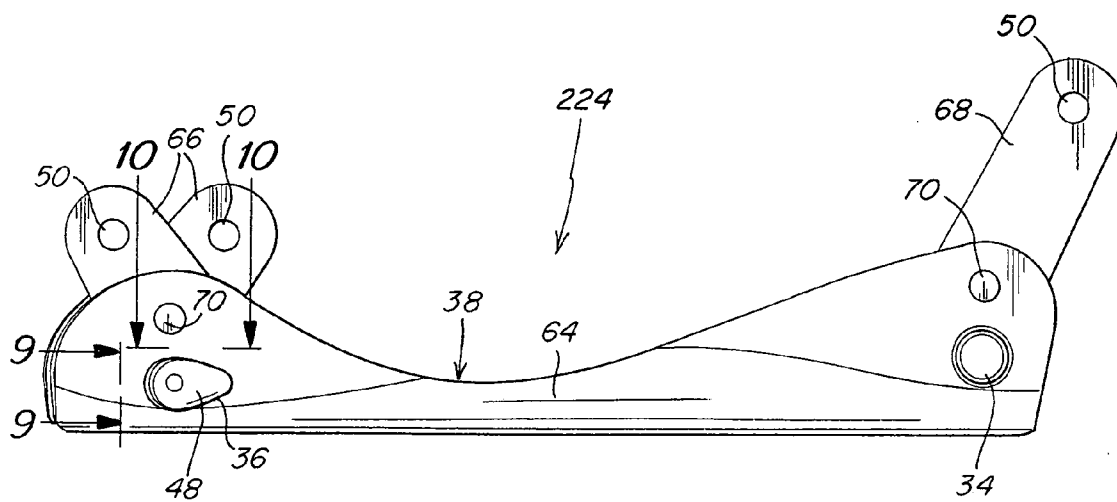

Fig. 8

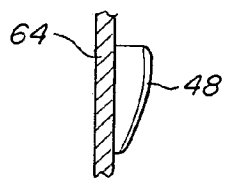

Fig. 9

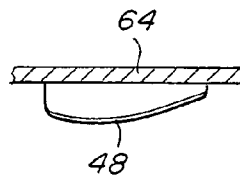

Fig. 10

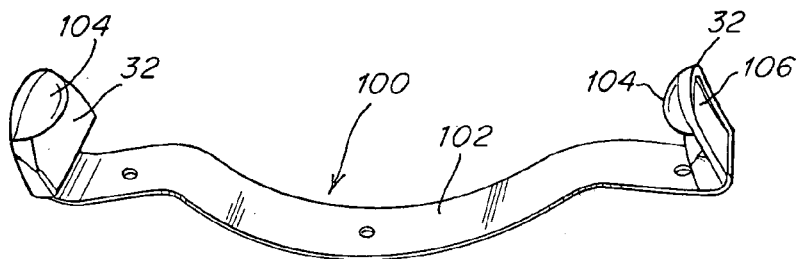

Fig. 11

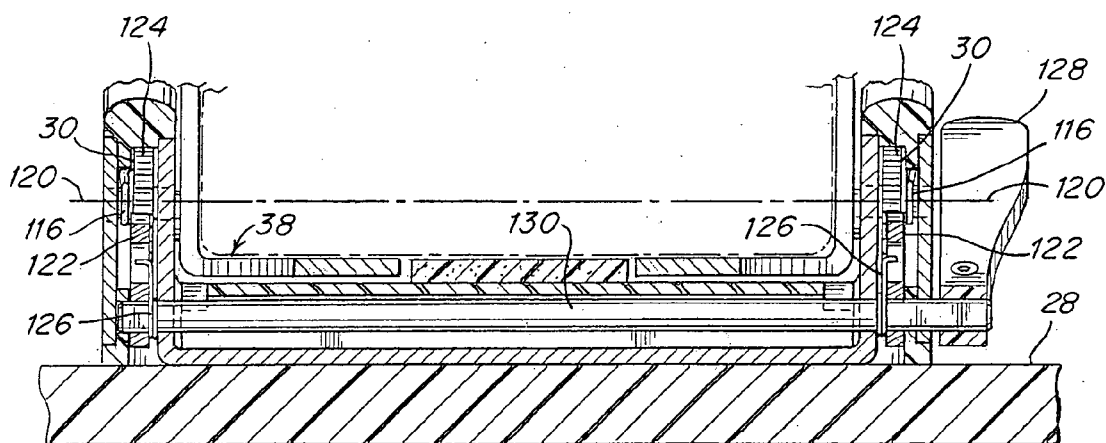

Fig. 12

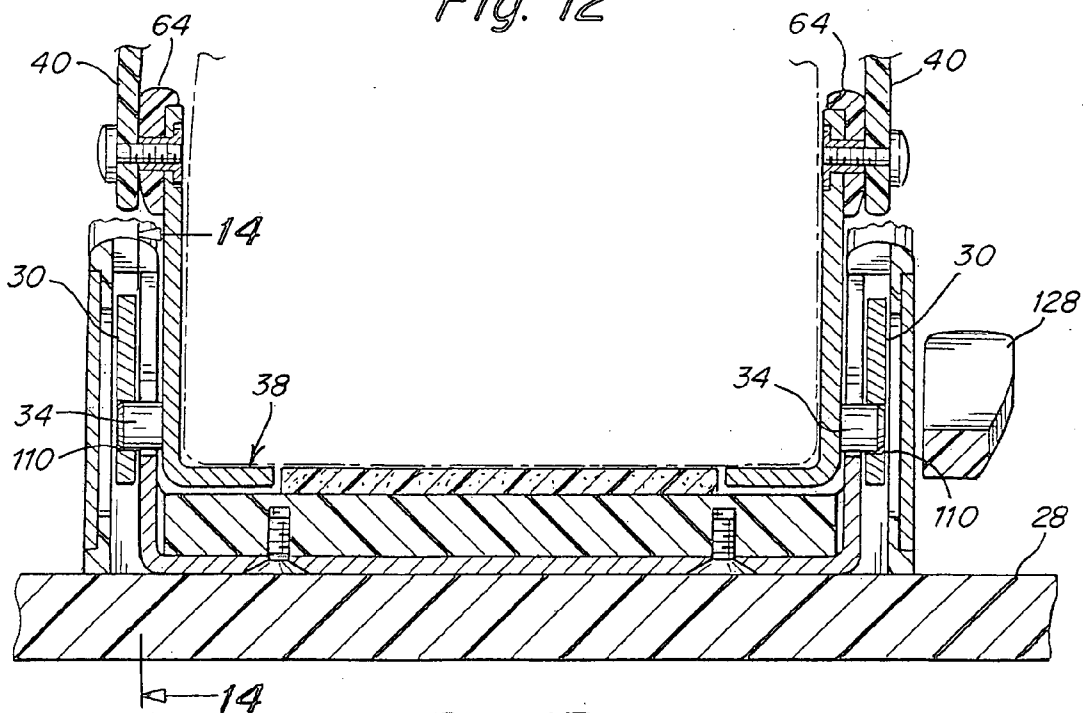

Fig. 13

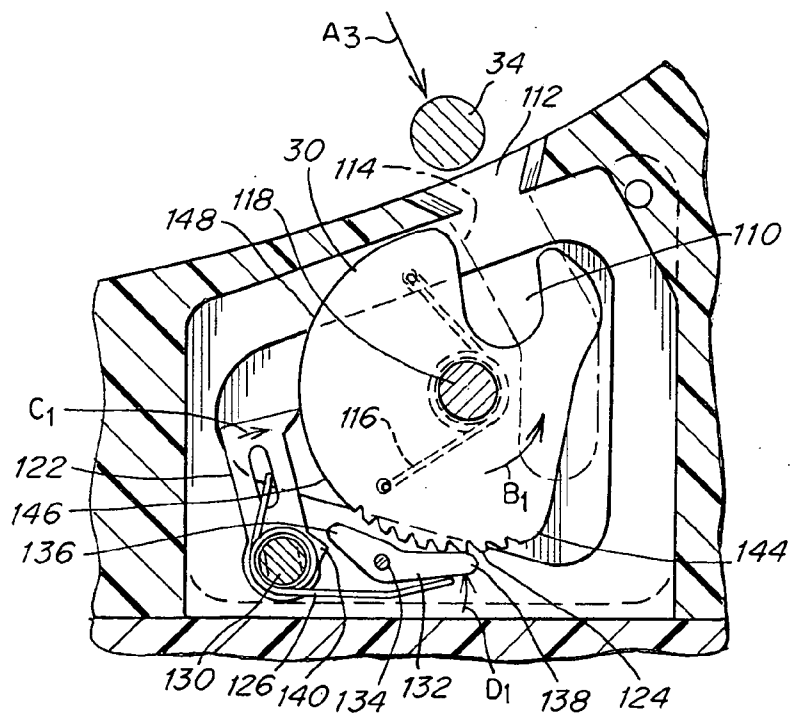

Fig. 14

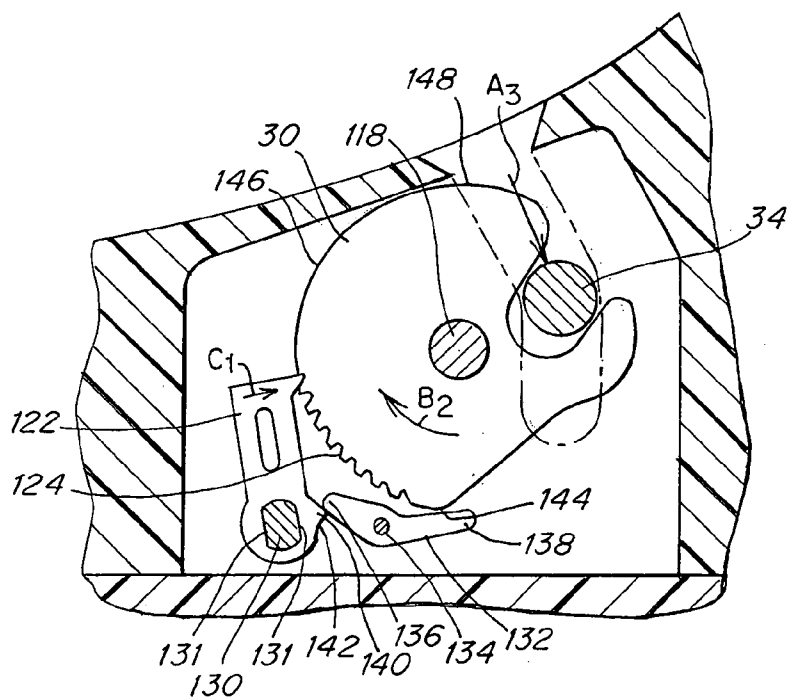

Fig. 15

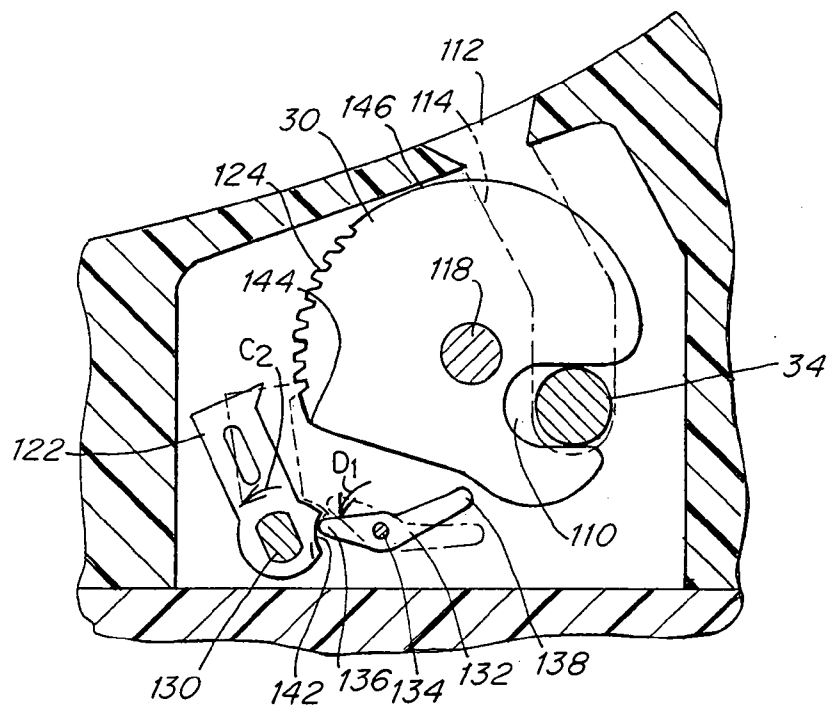

Fig. 16

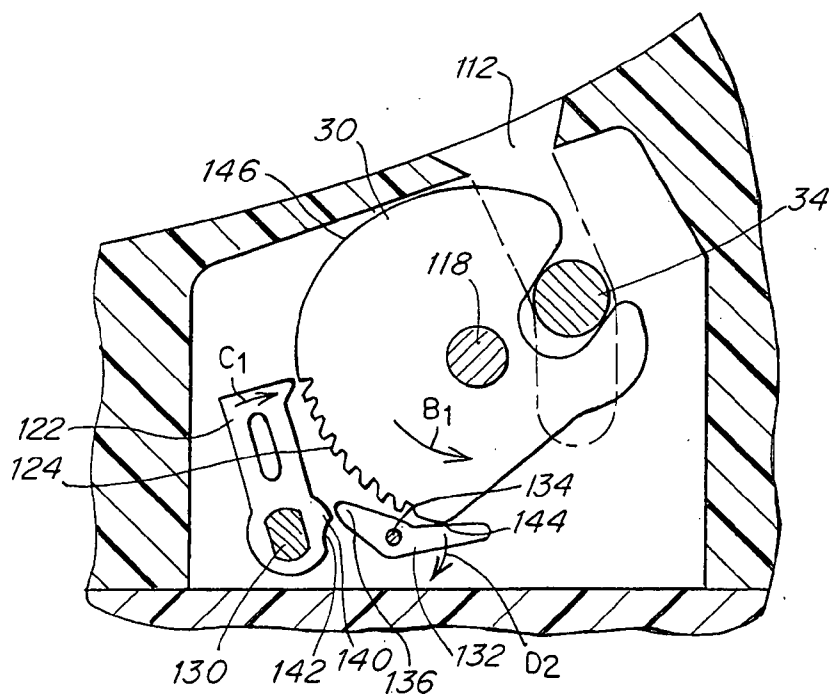

Fig. 17

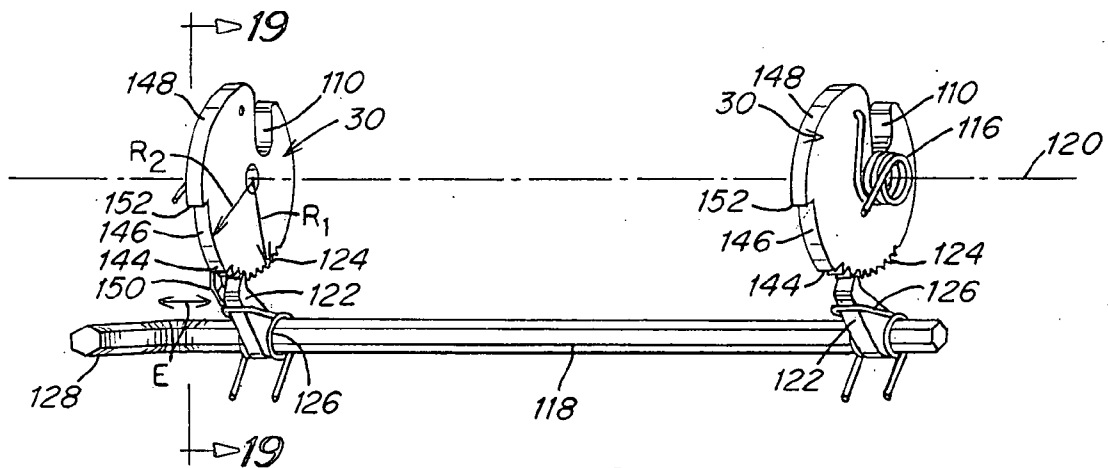

Fig. 18

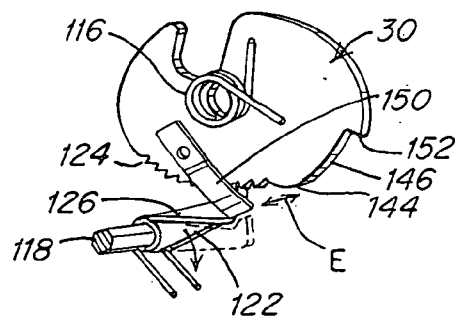

Fig. 19

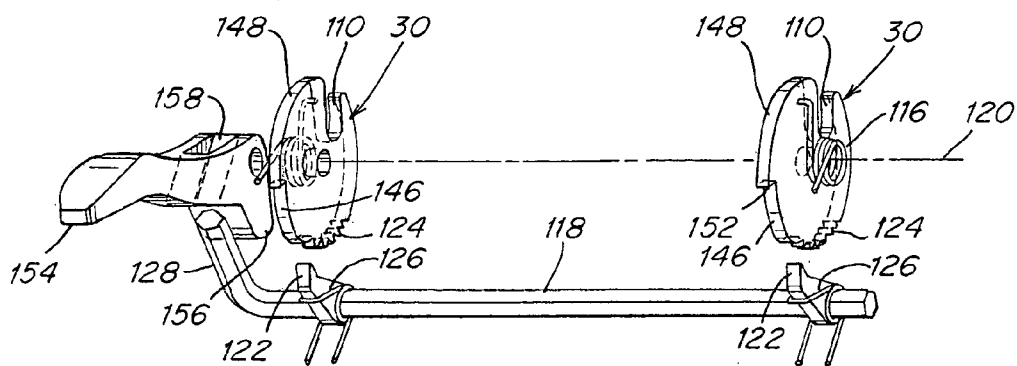

Fig. 20

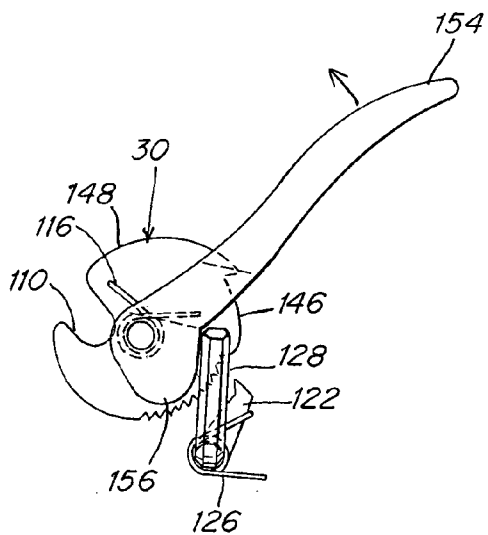

Fig. 21

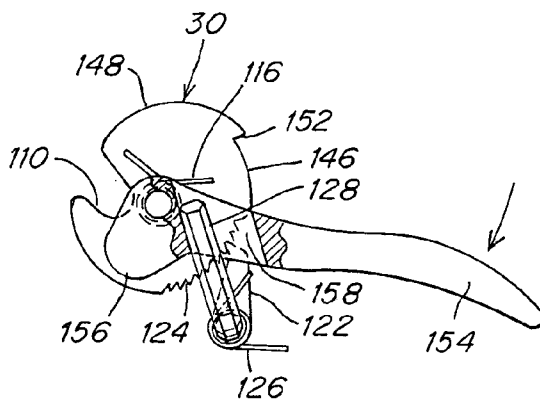

Fig. 22

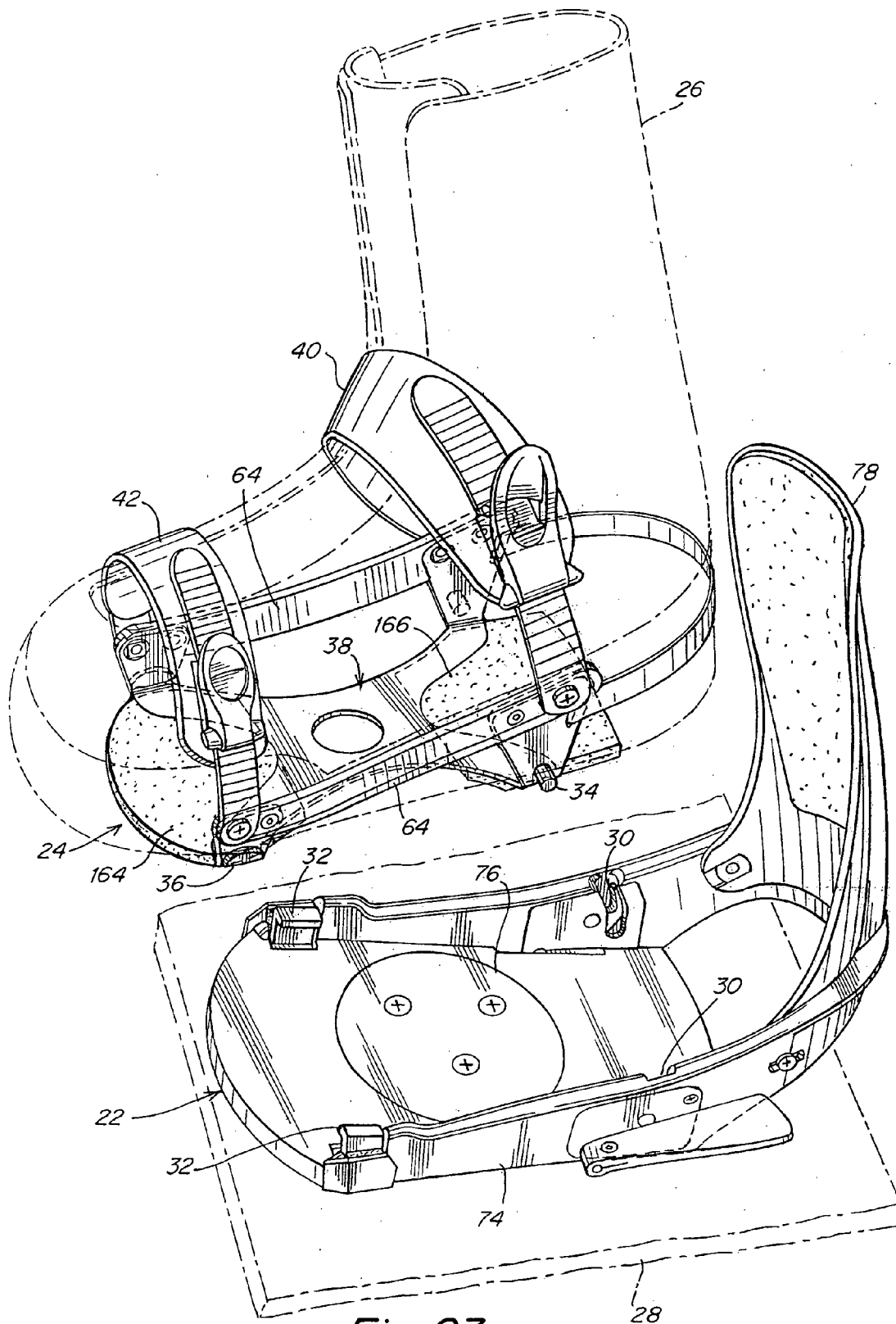

Fig. 23

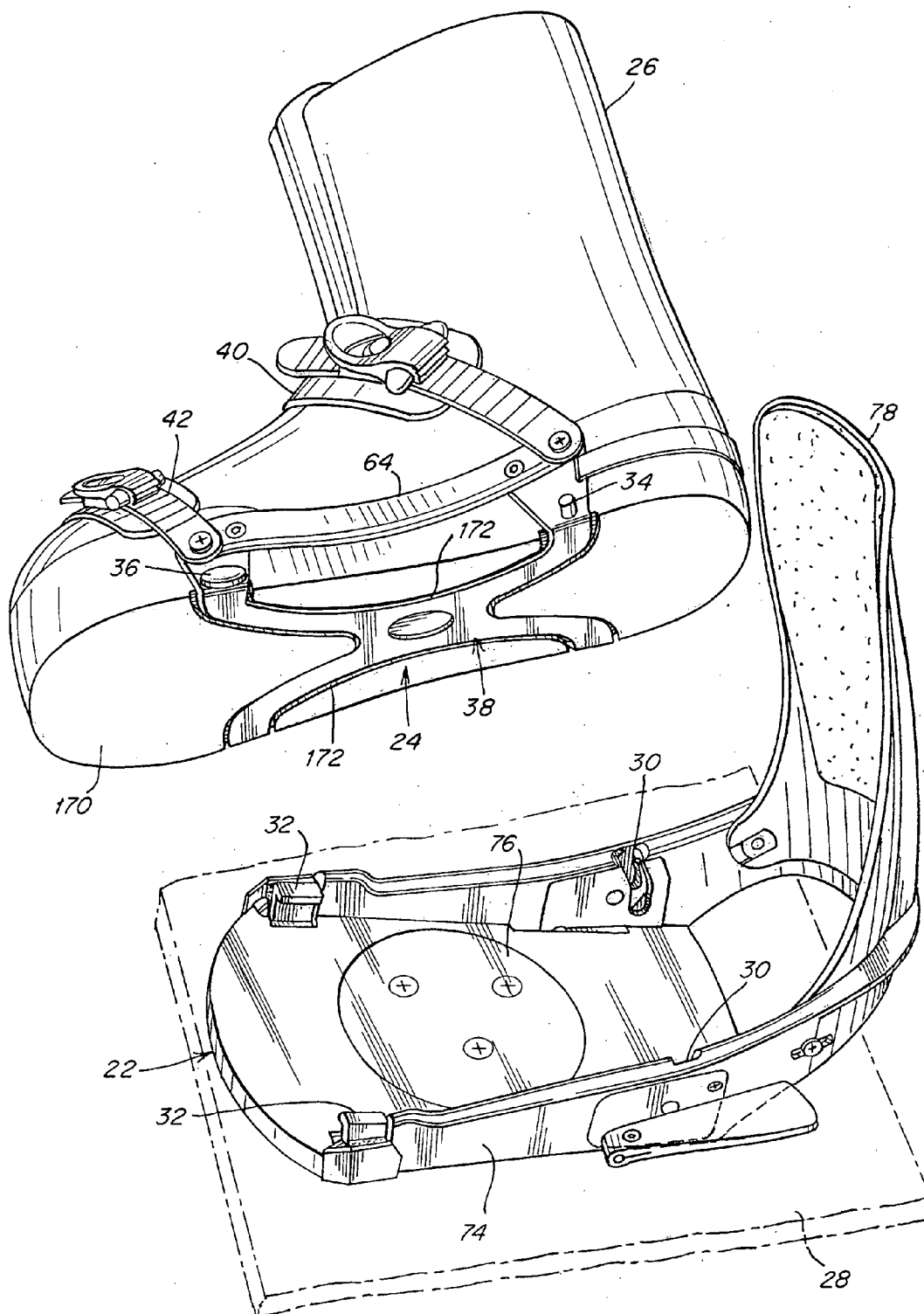

Fig. 24

INTERFACE FOR ENGAGING A SNOWBOARD BOOT TO A SNOWBOARD BINDING

[0001] This application is a continuation and claims the benefit of U.S. application Ser. No. 10/151,194, filed May 20, 2002, now pending, which is a divisional and claims the benefit of U.S. application Ser. No. 09/990,581, filed Nov. 21, 2001, now pending.

FIELD OF THE INVENTION

[0002] The present invention is directed generally to the field of bindings for gliding sports, and more particularly to the field of snowboard bindings.

BACKGROUND OF THE INVENTION

[0003] Snowboard binding systems used with soft snowboard boots typically are classified as one of two general types. A strap binding typically includes one or more straps that extend across a rider's boot to secure the boot to the binding. In contrast, a step-in binding typically employs one or more strapless engagement members, rather than straps, into which the rider can step to lock the boot into the binding. The strapless engagement members are configured to engage with one or more corresponding engagement members on the boot.

[0004] A strap binding typically delivers a feel or performance many riders find desirable. More particularly, a strap binding allows a rider's foot to roll laterally when riding by allowing the boot to roll relative to the binding. Some riders, however, may find a strap binding inconvenient because a rider must unbuckle each strap of the rear binding after each run to release the rear boot when getting on a lift, and must subsequently re-buckle each strap before the next run.

[0005] A step-in binding avoids the need to unbuckle and re-buckle straps each time a rider needs to release a boot from the binding. Many riders, however, find conventional step-in bindings undesirable for several reasons. First, most step-in bindings fail to deliver the desirable feel or performance associated with a strap binding. Rather, conventional step-in binding systems typically employ a rigid interface between the boot and binding that does not allow foot roll since the boot is rigidly attached to the binding. Second, a soft snowboard boot configured for use with a step-in binding typically requires a more rigid sole, as compared to a soft boot for a strap binding. Additionally, in many step-in systems, a rigid interface is attached to the sole of the boot, further reducing the comfort of the boot when walking.

[0006] It is an object of the present invention to provide an improved binding system for engaging a snowboard boot to a snowboard.

SUMMARY OF THE INVENTION

[0007] One embodiment of the present invention is directed to a binding system for securing a snowboard boot to a snowboard. The binding system comprises a binding interface and a snowboard binding base. The binding interface includes an interface body including medial and lateral sides with first and second regions provided along each of the medial and lateral sides, a first strap attached to the first region of the interface body and a second strap attached to the second region of the interface body. The first and second straps are constructed and arranged to extend across first and

second portions of the snowboard boot, forward of a heel portion thereof, to secure the binding interface to the snowboard boot. The snowboard binding base includes a base body, which has a heel end and a toe end, to be mounted to the snowboard. The snowboard binding base further includes at least one strapless engagement member, supported by the base body, that is to engage the binding interface at each of the first and second regions of the interface body along both the medial and lateral sides. A highback is supported at the heel end of the base body.

[0008] A further embodiment of the present invention is directed to a binding system for securing a snowboard boot to a snowboard. The binding system comprises a binding interface and a snowboard binding base. The binding interface includes an interface body, at least three mating features supported by the interface body, and first and second straps, supported by the interface body, to secure the binding interface to the snowboard boot. The first and second straps are constructed and arranged to extend across first and second portions of the snowboard boot forward of a heel portion thereof. The snowboard binding base includes a base body, which has a heel end and a toe end, to be mounted to the snowboard. The snowboard binding base further includes at least three engagement members, supported by the base body, that are adapted to engage the mating features of the binding interface. A highback is supported at the heel end of the base body.

[0009] Another embodiment of the present invention is directed to a binding system for securing a snowboard boot to a snowboard. The binding system comprises a binding interface and a snowboard binding base. The binding interface includes an interface body having a toe end and a heel end, a pair of first mating features supported at the heel end of the interface body, a pair of second mating features supported at the toe end of the interface body, and at least one strap, supported by the interface body, to secure the binding interface to the snowboard boot. The snowboard binding base includes a base body to be mounted to the snowboard. The base body has a toe end and a heel end, and a highback supported at the heel end of the base body. The snowboard binding base also includes a pair of first engagement members, each of the pair of first engagement members being movably supported at the heel end of the base body between at least one closed position to engage a corresponding one of the pair of first mating features of the interface and an open position to release the corresponding one of the pair of first mating features. The snowboard binding base further includes a pair of second engagement members supported at the toe end of the base body to engage the pair of second mating features of the interface.

[0010] A further embodiment of the present invention is directed to a binding system for securing a snowboard boot to a snowboard. The binding system comprises a binding interface and a snowboard binding base. The binding interface includes an interface body having a toe end, a heel end and lateral and medial sides, a pair of first mating features, one each supported along the lateral and medial sides of the interface body, a pair of second mating features, one each supported along the lateral and medial sides of the interface body, and at least one strap supported by the interface body to secure the binding interface to the snowboard boot. The snowboard binding base includes a base body to be mounted to the snowboard. The base body has lateral and medial

sides, and a highback supported at the heel end of the base body. The snowboard binding base also includes a pair of first engagement members, one each movably supported along the lateral and medial sides of the base body between at least one closed position to engage a corresponding one of the pair of first mating features of the interface and an open position to release the corresponding one of the pair of first mating features. The snowboard binding base further includes a pair of second engagement members that are independent of the pair of first engagement members. One each of the pair of second engagement members is supported along the lateral and medial sides of the base body. Each of the pair of second engagement members is adapted to engage a corresponding one of the pair of second mating features of the interface.

[0011] Another embodiment of the present invention is directed to a snowboard binding to secure a snowboard boot to a snowboard. The snowboard binding comprises a base including a toe end and a heel end, and a highback supported at the heel end of the base. The snowboard binding also comprises a pair of first engagement members supported by the base, the pair of first engagement members being adapted to engage a pair of first mating features supported along opposing sides of the snowboard boot. Each of the pair of first engagement members is movable between an open position to release a corresponding one of the pair of first mating features and at least one closed position to secure the corresponding one of the pair of first mating features. The snowboard binding further comprises a pair of second engagement members supported by the base, the pair of second engagement members being adapted to receive the snowboard boot therebetween and to engage a pair of second mating features supported along the opposing sides of the snowboard boot. The pair of first engagement members is moveable independently of the pair of second engagement members.

[0012] A further embodiment of the present invention is directed to a snowboard binding to secure a snowboard boot to a snowboard. The snowboard binding comprises a base, and a pair of engagement members, supported by the base, to engage a pair of mating features supported by the snowboard boot. Each of the pair of engagement members is movable independently of the other between an open position to release a corresponding one of the pair of mating features and at least one closed position to secure the corresponding one of the pair of mating features. The snowboard binding further comprises a locking mechanism adapted to move between a locking position to maintain each of the pair of engagement members in the at least one closed position and a release position to permit movement of each of the pair of engagement members to the open position. The locking mechanism is movable to the locking position only when each of the pair of engagement members is moved to the closed position.

[0013] Another embodiment of the present invention is directed to a binding system for securing a snowboard boot to a snowboard. The binding system comprises a binding interface and a snowboard binding base. The binding interface includes an interface body, at least one pair of mating features supported by the interface body, and at least one strap supported by the interface body to secure the binding interface to the snowboard boot. The snowboard binding base includes a base body including a medial side and a

lateral side, the base body to receive a snowboard boot between the medial and lateral sides. The snowboard binding base also includes at least one pair of engagement members to engage the at least one pair of mating features. One each of the pair of engagement members is movably supported on the medial and lateral sides of the base body. Each of the pair of engagement members is movable between an open position to release a corresponding one of the pair of mating features and a plurality of separately lockable closed positions to secure the corresponding one of the pair of mating features. The snowboard binding base further includes a locking mechanism adapted to move between a locking position to maintain each of the pair of engagement members in each of its plurality of closed positions and a release position to permit movement of each of the pair of engagement members to its open position.

[0014] A further embodiment of the present invention is directed to an interface for coupling a snowboard boot to a snowboard binding base, the snowboard binding base having a toe end and a heel end and including a highback at the heel end thereof, the snowboard binding base including a pair of first engagement members at the heel end thereof and a pair of second engagement members at the toe end thereof. The interface comprises an interface body having a toe end and a heel end that is free of a highback, a pair of first mating features supported at the heel end of the interface body, the pair of first mating features to be engaged by the pair of first engagement members, and a pair of second mating features supported at the toe end of the interface body, the pair of second mating features to be engaged by the pair of second engagement members. The binding interface further comprises first and second straps supported by the interface body to secure the binding interface to the snowboard boot. The first strap is attached to the heel end of the interface body and the second strap is attached to the toe end of the interface body.

[0015] Another embodiment of the present invention is directed to an interface for coupling a snowboard boot to a snowboard binding base, the snowboard boot including a sole, the snowboard binding base having a toe end and a heel end and including at least one first engagement member and at least one second engagement member. The interface comprises an interface body including medial and lateral sides and front and rear edges extending between the medial and lateral sides. The front and rear edges are spaced apart a first distance in a longitudinal direction along a length of the interface body between the medial and lateral sides. The binding interface also comprises at least one first mating feature supported by the interface body and at least one second mating feature supported by the interface body. The at least one first mating feature is to be engaged by the first engagement member and the at least one second mating feature is to be engaged by the second engagement member. The at least one second mating feature is spaced from the at least one first mating feature by a second distance in the longitudinal direction that is greater than the first distance. The binding interface further comprises at least one strap supported by the interface body to secure the binding interface to the snowboard boot.

[0016] A further embodiment of the present invention is directed to an interface for coupling a snowboard boot to a snowboard binding base, the snowboard boot including a sole, the snowboard binding base including at least one pair

of engagement members. The interface comprises an interface body including a lower portion that is to be mounted below at least a portion of the sole of the snowboard boot. The lower portion has an X-shaped configuration. The binding interface further comprises at least one pair of mating features supported by the interface body to be engaged by the at least one pair of engagement members, and at least one strap supported by the interface body to secure the binding interface to the snowboard boot.

[0017] Another embodiment of the present invention is directed to an interface for coupling a snowboard boot to a snowboard binding base, the snowboard binding base including a highback at a heel end thereof, the snowboard binding base including a pair of first engagement members and a pair of second engagement members. The interface comprises an interface body including medial and lateral sides with first and second regions provided along each of the medial and lateral sides. The interface also comprises a pair of first mating features to be engaged by the pair of first engagement members of the snowboard binding base and a pair of second mating features to be engaged by the pair of second engagement members of the snowboard binding base. One each of the pair of first mating features is supported at the first regions along both the medial and lateral sides of the interface body, and one each of the pair of second mating features is supported at the second regions along both the medial and lateral sides of the interface body. The interface further comprises first and second straps constructed and arranged to extend across first and second portions of the snowboard boot, forward of a heel portion thereof, to secure the binding interface to the snowboard boot. The first strap is attached to the first regions of the interface body and the second strap is attached to the second regions of the interface body.

[0018] A further embodiment of the present invention is directed to an interface for coupling a snowboard boot to a snowboard binding base, the snowboard binding base having a toe end and a heel end and including a highback at the heel end thereof, the snowboard binding base including at least one pair of engagement members that is movable between an open position and a closed position. The interface comprises an interface body that is free of a highback, at least one pair of mating features supported by the interface body, and at least one strap supported by the interface body to secure the binding interface to the snowboard boot. The at least one pair of mating features is adapted to automatically move the at least one pair of engagement members to the open position, without manual actuation of the at least one pair of engagement members by a rider, when the interface body is stepped into and out of the snowboard binding base.

BRIEF DESCRIPTION OF THE DRAWINGS

[0019] The foregoing and other objects and advantages of the invention will be appreciated more fully from the following drawings, wherein like reference characters designate like features, in which:

[0020] FIG. 1 is an exploded perspective view of a binding system according to one illustrative embodiment of the invention;

[0021] FIG. 2 is a partially exploded perspective view of a binding base and a binding interface of the binding system

of FIG. 1, with the straps and highback removed for clarity, illustrating the interface being secured to the binding base;

[0022] FIG. 3 is a cross-sectional side view of the binding system taken along section line 3-3 of FIG. 2 illustrating the binding interface with a boot fully secured to the binding base;

[0023] FIG. 4 is a cross-sectional side view of the binding system taken along section line 4-4 of FIG. 2 illustrating the binding interface being stepped into the binding base;

[0024] FIG. 5 is a cross-sectional lateral view taken along section line 5-5 of FIG. 3 illustrating a toe mechanism of the binding system;

[0025] FIG. 5a is a partial, cross-sectional top view taken along section line 5a-5a of FIG. 1 illustrating a toe lug of the binding interface;

[0026] FIG. 6 is a schematic side view of a binding interface illustrating the relative locations between strap attachment points and interface mating features;

[0027] FIG. 7 is a perspective view of another illustrative embodiment of a binding interface for use in a binding system according to the present invention;

[0028] FIG. 8 is a side elevational view of the binding interface of FIG. 7;

[0029] FIG. 9 is a partial, cross-sectional front view taken along section line 9-9 of FIG. 8 illustrating a toe lug of the binding interface of FIGS. 7-8;

[0030] FIG. 10 is a partial, cross-sectional top view taken along section line 10-10 of FIG. 8 illustrating the toe lug of the binding interface of FIGS. 7-9;

[0031] FIG. 11 is a perspective schematic view of another embodiment of a toe mechanism for use with the binding system of the present invention;

[0032] FIG. 12 is a cross-sectional lateral view taken along section line 12-12 of FIG. 3 illustrating a heel mechanism of the binding system of FIGS. 1-4;

[0033] FIG. 13 is a cross-sectional lateral view taken along section line 13-13 of FIG. 3 illustrating the heel mechanism of the binding system of FIGS. 1-4;

[0034] FIG. 14 is a fragmentary, cross-sectional side view of the heel mechanism taken along section line 14-14 of FIG. 13 illustrating a heel mating feature of the binding interface being inserted into the binding heel mechanism in the open position;

[0035] FIG. 15 is a schematic cross-sectional side view of the heel mechanism of FIG. 14 illustrating the heel mating feature being secured by the heel mechanism in an initial closed position;

[0036] FIG. 16 is a schematic cross-sectional side view of the heel mechanism of FIGS. 12-15 illustrating the heel mating feature being secured by the heel mechanism in a fully closed position;

[0037] FIG. 17 is a schematic cross-sectional side view of the heel mechanism of FIGS. 12-15 illustrating the heel mating feature being released from the heel mechanism;

[0038] FIG. 18 is a perspective schematic view of another illustrative embodiment of a heel mechanism for use in a binding system according to the present invention;

[0039] FIG. 19 is a cross-sectional side view taken along section line 19-19 of FIG. 18;

[0040] FIG. 20 is a perspective schematic view of a further illustrative embodiment of a heel mechanism for use in a binding system according to the present invention;

[0041] FIG. 21 is a side view of the heel mechanism of FIG. 20 in the release position;

[0042] FIG. 22 is a partially fragmented side view of the heel mechanism of FIG. 20 in the locking position;

[0043] FIG. 23 is an exploded perspective view of a binding system according to another illustrative embodiment of the invention; and

[0044] FIG. 24 is an exploded perspective view of a binding system according to a further illustrative embodiment of the invention.

DETAILED DESCRIPTION

[0045] The present invention is directed to an improved snowboard binding system that incorporates the riding performance of a strap binding with the convenience of a step-in binding. This may be accomplished with a two-piece binding system that includes: (1) a binding base that includes a highback; and (2) a binding interface that includes one or more straps and is configured to be coupled to the base in a manner similar to a step-in binding. Thus, when the interface is coupled to the binding base, the binding operates like, and provides the performance and feel, of a conventional strap binding. However, between runs, a rider can remove the interface from the binding base with the convenience of a step-in binding (e.g., to negotiate a lift line and get on a chair lift).

[0046] One aspect of the binding system is directed to an improved step-in binding. Another aspect of the binding system is directed to a binding interface for coupling a snowboard boot to a snowboard binding base. Although the binding base and the binding interface may be advantageously employed together, the present invention is not limited in this respect, as each of these aspects of the present invention can also be employed separately. For example, the snowboard binding base may be employed to directly engage a snowboard boot, rather than engage a snowboard boot through a separate interface. Similarly, the binding interface may be employed with numerous types of binding bases, and is not limited to use with the illustrative embodiments disclosed herein.

[0047] The binding system may be configured so that the binding base engages regions of the binding interface to which one or more straps are attached to provide a feel similar to that of a strap binding. In this regard, each engagement region can include a strap attachment point and a binding mating feature that are positioned relative to each other so that forces exerted on the strap are transmitted through the mating feature to the binding in a manner that achieves a desired feel. Such a system configuration may facilitate the transmission of forces exerted on a strap, through the interface, to the binding base in a manner similar to a conventional strap binding in which forces are trans-

mitted directly to a binding baseplate through a strap mounted directly to the baseplate.

[0048] In one embodiment, the binding system may employ a four point engagement between the binding interface and the binding base. Such an arrangement may substantially reduce, if not eliminate, movement between the interface and the binding base so that movement of a boot relative to the binding base may be controlled by the manner in which the boot is secured to the binding base through the interface. The arrangement causes the binding system to have the performance and feel of a strap binding by transmitting forces exerted by a rider to four points of engagement similar to the strap attachment points of a strap binding. This arrangement may also simulate the feel of a strap binding system by allowing structure to be eliminated from below the heel and toe regions of a rider's foot. In this regard, corresponding pairs of interconnect features between the interface and binding base may be arranged along the lateral and medial sides of the boot. It is to be appreciated, however, that other embodiments of the binding system do not employ a four-point engagement configuration.

[0049] In one embodiment, the binding interface may be configured with multiple binding straps to deliver a rider with the desired feel associated with strap bindings. In this regard, the interface may include an ankle strap and a toe strap that are arranged to extend across the in-step or ankle portion and the toe portion, respectively, of a rider's foot in a manner similar to a conventional strap binding. The straps may be attached to regions of the interface adjacent the interconnect features between the interface and binding base so that forces exerted by a rider on the straps are transmitted directly to regions of the binding in a manner similar to a conventional strap binding. It is to be understood, however, that other embodiments do not use multiple binding straps. Additionally, other embodiments do not attach the straps adjacent the interconnect features between the interface and the binding base.

[0050] In one embodiment, the binding base may include a pair of engagement members at both the rear or heel end and the front or toe end of the binding to engage with corresponding mating features on the interface. The engagement members may be located along regions of the binding base that correspond to the strap attachment points for a conventional strap binding. In other embodiments, the binding base does not employ a pair of engagement members at the heel and toe end. Additionally, other embodiments do not locate the engagement members along regions of the binding base that correspond to the strap attachment points.

[0051] In one embodiment, the engagement members at the heel end of the binding base may be configured to move independently of the engagement members at the toe end of the binding base to facilitate stepping the interface into and out of the base. In other embodiments, independent movement is not employed between the engagement members at the heel and toe ends of the binding.

[0052] In one embodiment, the binding base may be provided with a locking arrangement that reduces the likelihood of a false locking condition between the interface and binding base by prohibiting at least one of the pairs of engagement members from becoming locked until each of the pair of engagement members assumes its closed posi-

tion. It is to be appreciated, however, that such a locking arrangement is not employed in all embodiments of the binding base.

[0053] In one embodiment, the binding base may be configured to accommodate an accumulation of snow, ice or other debris between the binding base and the interface and/or boot. Other embodiments of the binding base do not accommodate an accumulation of snow, ice or other debris.

[0054] In one illustrative embodiment shown in FIGS. 1-4, the binding system 20 includes a binding base 22 and a binding interface 24 that is configured to cooperate with the base to secure a snowboard boot 26 to a snowboard 28. The binding system employs an engagement arrangement between the interface 24 and the base 22 that is configured to simulate the feel and riding performance associated with a strap binding. In this regard, in one embodiment the binding system employs an engagement arrangement in which the interface is attached to the binding base in the region of each strap. For example, when the binding system employs two straps, a four point engagement (two points on each side of the interface and the binding base with each point in a region of one of the straps) is provided between the interface and the base. It is to be appreciated, however, that the binding system may be configured to employ any number of engagement points greater than or less than four engagement points. Furthermore, in other embodiments of the invention, the binding system does not have engagement points aligned with strap mounting positions.

[0055] As illustrated, the binding system includes a pair of opposing engagement members 30 at the rear or heel end of the binding base and a pair of opposing engagement members 32 at the front or toe end of the base that cooperate with pairs of corresponding mating features 34, 36 on the interface 24 to secure the interface to the base. The heel end and the toe end of the binding correspond to regions that are located, respectively, rearward and forward of the arch area of a rider's foot. In one embodiment, the pairs of opposing engagement members are located at the heel and toe ends of the binding base so as to be in the regions where the straps are attached to the interface. It is to be understood, however, that the engagement members may be located in any desirable locations along the binding base.

[0056] In the illustrative embodiment of FIGS. 1-4, the binding interface 24 includes an interface body 38 and multiple binding straps that are configured to extend across portions of a snowboard boot to secure the boot to the interface. In one embodiment, the interface includes an ankle strap 40 and a toe strap 42 that are respectively arranged to extend across the ankle and toe portions of a snowboard boot 26 in a manner similar to a conventional strap binding. In this regard, once the binding interface 24 is coupled to the binding base 22, the binding system will deliver a desired feel and riding performance typically associated with a strap binding.

[0057] In the illustrative embodiment, the ankle and toe straps 40, 42 each includes a ratchet-type buckle 44, 46 to enable adjustment of the strap across the boot by a rider. In this regard, the binding interface may employ adjustable straps similar to those used on a strap binding. However, it is to be understood that the present invention is not limited to the use of any particular number or type of strap, as numerous other strap arrangements, including arrangements

with a single strap or more than two straps, may be employed for securing a boot to the interface, and consequently to the snowboard when the interface is coupled to the binding base. Thus, as used herein, the term strap is intended to indicate any structure that passes over the boot upper and performs this attachment function, including web-like structures, bails and the like.

[0058] The interface 24 may include one or more mating features that are adapted to engage with a corresponding strapless engagement member provided on the binding base. As indicated above, the interface 24 is not limited to use with any particular binding base and, therefore, is not limited to the use of any particular mating features for engaging with a binding base. Notwithstanding the foregoing, the interface will be described below in connection with a binding system that employs an attachment configuration wherein strapless engagement members are provided in regions where the straps are attached to the interface. Thus, for an interface including two straps, a four-point attachment configuration is employed for the binding system.

[0059] In the illustrative embodiment shown in FIGS. 1-4, the binding interface 24 includes a pair of mating features 34 at a rear or heel end of the interface body and a pair of mating features 36 at the front or toe end of the interface body. As illustrated, each pair of mating features extends outwardly from opposing medial and lateral sides of the interface body 38 so that the mating features are disposed along respective medial and lateral sides of a boot when the interface is mounted to the boot. In this regard, the mating features do not underlie the sole of the boot to ensure that the binding system has a feel similar to that of a strap binding. It is to be appreciated, however, that all embodiments of the present invention are not limited in this manner, as any suitable interface configuration may be employed consistent with a binding base configuration, including the placement of one or any combination of mating features to underlie the snowboard boot.

[0060] As indicated above, the interface may employ mating features having any configuration suitable for mating with corresponding engagement members provided on the binding base. In the illustrative embodiment shown in FIGS. 1-4, the interface 24 includes a pair of circular pins 34 extending outwardly from the medial and lateral sides of the heel end of the interface body 38. The circular shape of the pins 34 cam the corresponding engagement members 30 of the binding base open and closed upon stepping out of and into the base. The circular shape also facilitates the displacement of snow, ice and other debris from the engagement members.

[0061] The interface 24 further includes a pair of lugs 36 that project outwardly from the medial and lateral sides of the toe end of the interface body. As illustrated, the toe lugs 36 have a generally oval shape with a curved outward facing cam surface 48 (FIGS. 5-5a) configured to cam or wedge the corresponding engagement members 32 of the binding base open upon stepping into and out of the binding base. In one embodiment, the cam surface 48 is tapered in the vertical (top-to-bottom) direction and the longitudinal (toe-to-heel) direction to provide the desired wedging action.

[0062] It is to be understood that any suitable configuration may be employed for any of the interface mating features, and that all embodiments of the binding interface

are not limited to the particular configurations illustrated in this embodiment. It is also to be understood that each of the mating features (e.g., those at the toe and heel ends) may have the same configuration, rather than different configurations as illustrated.

[0063] In one embodiment, the interface **24** is configured so that the forces exerted by a rider on the ankle and toe straps are transmitted to the binding in a manner similar to a strap binding, so that the binding system has the performance and feel of a conventional strap system. In the illustrative embodiment shown in **FIGS. 1-4**, the interface body **38** includes at least one strap attachment point **50** adjacent each of the heel and toe mating features **34, 36** for respectively mounting the ankle and toe straps **40, 42** to the medial and lateral sides of the interface body. In this regard, forces exerted on the straps are transmitted through the mating features **34, 36** and to the binding in a manner similar to a strap binding, wherein the ankle and toe straps are conventionally mounted to the medial and lateral sidewalls of the base. As illustrated, the interface body **38** may include multiple attachment points **50** for each of the ankle and toe straps to provide a rider with a degree of strap adjustability for comfort and/or riding characteristics typically associated with a strap binding.

[0064] As discussed above, it is desirable to position the heel and toe mating features **34, 36** adjacent their corresponding strap attachment positions **50** to provide the performance and feel of a strap binding. In this regard, locating the mating features **34, 36** adjacent the strap attachment locations **50** refers to positioning the mating features and the strap attachment locations within the same region of the interface. It is to be understood, however, that this is not a limitation of all embodiments of the invention, and any suitable strap mounting arrangement may be employed with the binding interface in accordance with other embodiments.

[0065] As schematically illustrated in **FIG. 6**, one embodiment of the binding interface **22** includes first and second regions **49, 51** extending in a longitudinal direction along each side of the interface body **38**. The first and second regions **49, 51** each includes at least one strap attachment point **50** for one of the first and second straps **40, 42** (e.g., ankle and toe straps). The interface and the binding base are configured so that the strapless engagement mechanism directly engages the interface at each of the first and second regions **49, 51**. In one embodiment, the first and second regions are configured so that the interface is engaged by the strapless engagement mechanism on both sides of a mid-point **53** located midway between the strap attachment points **50**.

[0066] As discussed above, the engagement mechanism is configured to engage first and second mating features provided on the interface body. In the illustrative embodiment, the first mating feature **34** is located in the first region **49** and the second mating feature **36** is located in the second region **51**. Each mating feature **34, 36** may be positioned relative to its corresponding strap attachment point **50** to achieve a desired feel.

[0067] In the illustrative embodiment of **FIG. 6**, the relative positions of the mating features **34, 36** to their corresponding strap attachment points **50** are defined by longitudinal distances L_1, L_2 between the mating feature and its corresponding attachment point. According to one illus-

trative embodiment, the distance is based on a percentage of the overall distance L_0 between the strap attachment points **50** for the first and second straps **40, 42**. The distances L_1, L_2 between the mating features **34, 36** and their corresponding attachment points **50** are preferably less than 50% of the overall distance L_0 , more preferably within 45% of the overall distance L_0 , even more preferably within 40% of the overall distance L_0 , more preferably within 35% of the overall distance L_0 , even more preferably within 30% of the overall distance L_0 , more preferably within 25% of the overall distance L_0 , even more preferably within 20% of the overall distance L_0 , more preferably within 15% of the overall distance L_0 , even more preferably within 10% of the overall distance L_0 , more preferably within 5% of the overall distance L_0 , and even more preferably the mating features and their corresponding strap attachment points are vertically aligned with each other.

[0068] It is to be understood that the above distances between the mating features and strap attachment points are merely exemplary and other distances are possible. For example, although discussed above as a percentage of the overall distance L_0 in increments of 5%, the distances L_1, L_2 between the mating features **34, 36** and their strap attachment points **50** may be any percentage of the overall distance L_0 , in increments of 1% or any other desirable increment. The relative positions between the mating features and the attachment points may also differ between the first and second regions. For example, the distance L_1 between the first mating feature **34** and the attachment point for the first strap **40** may be within 35% of the overall distance L_0 , while the distance L_2 between the second mating feature **36** and the attachment point for the second strap **42** may be within 20% of the overall distance L_0 . Further, although the mating features are illustrated as being located below or along regions of the interface between the heel and toe strap attachment points, the heel and toe mating features **34, 36** may be located below or along regions of the interface extending beyond the attachment points in the heel and toe directions, respectively.

[0069] One desirable characteristic of the binding system **20** (**FIGS. 1-4**) is its ability to be employed to secure a snowboard boot of any configuration to a snowboard. In this regard, the embodiment shown in the figures employs a universal binding interface **24** that is configured to be mounted to any type of snowboard boot, without requiring that the boot be configured for use with this system.

[0070] In the illustrative embodiment shown in **FIGS. 1-4**, the interface **24** includes a heel strap **52** that is configured to extend about the heel portion of a boot to facilitate proper location of the interface body **38** relative to the boot in the toe-to-heel direction. The opposing ends of the heel strap **52** are mounted to the medial and lateral sides of the heel end of the interface body. In one embodiment, the heel strap is formed from a material having a degree of stiffness such that the heel strap maintains its shape to allow a boot to be stepped into or out of the interface without having to manipulate the heel strap to ensure that it properly engages the boot. For example, the heel strap **52** may be formed from a plastic material, such as a molded polyurethane. It is to be understood, however, that the strap can be formed from any suitable material.

[0071] As indicated above, the various mating features may be located on the interface body so that they do not

underlie a rider's boot to ensure that the binding system has the feel of a strap binding. In this regard, a rider's boot is generally in direct contact with and rolls across the surface of the base of a strap binding. Consequently, it may be desirable to configure the interface **24** so that at least some portions of a snowboard boot **26**, when secured to the binding with the interface, directly engage the binding base to achieve a feel similar to a strap binding.

[0072] In one illustrative embodiment shown in **FIGS. 1-2**, the interface body **38** is configured so that a minimal amount of material is presented below the toe and heel regions of the boot when the interface is mounted to the boot to allow direct contact between the toe and heel regions of the boot with the binding. As illustrated, the lower portion of the interface body **38** which underlies the boot sole includes generally U or V-shaped front and rear edges **54, 56** that converge and diverge toward and away from each other as the edges extend across the width of the interface between the medial and lateral sides of the interface body. This results in an interface body **38** having a lower portion with a generally X shape (e.g., an hourglass or similar shape) that underlies the snowboard boot in which the amount of material below the toe and heel regions of the boot sole decreases as the front and rear edges extend inwardly away from the medial and lateral sides of the interface body. It is to be understood, however, that the interface body **38** is not limited to a hourglass or X shape, as any suitable configuration may be implemented to minimize the amount of material below the toe and heel regions of a boot. Alternatively, in other embodiments, the amount of material does not need to be minimized under the foot, as other configurations are possible.

[0073] The lower portion of the interface body includes a central region **58** that underlies the arch portion of the boot and a plurality of arms **60** extending away from the central region to the locations corresponding to the toe and heel portions of a boot for supporting the mating features **34, 36** of the interface at desired locations relative to the boot. As illustrated (**FIG. 1**), the longitudinal distance L_3 between the front and rear mating features **34, 36** along the medial and lateral sides of the interface is greater than the longitudinal distance L_4 between the front and rear edges **54, 56** of the interface body as the edges converge toward each other along at least a portion of the lower portion between the medial and lateral sides. In this regard, the front and rear mating features may be located at the toe and heel portions of the boot while reducing the amount of material that underlies the toe and heel portions of the boot. As indicated above, however, the amount of material does not need to be reduced under the boot in all embodiments of the interface.

[0074] The central region **58** of the lower portion is provided with an aperture **62** of any shape to further reduce the weight of the interface body. In other embodiments of the interface, however, such an aperture is not employed.

[0075] In addition to minimizing the amount of material between the boot and the binding base, the illustrative configuration of the interface also enhances the torsional stability of the interface body. The overall stiffness of the interface **24** is increased, as shown in the illustrative embodiment, with sidewalls **64** that interconnect toe and heel mounting ears **66, 68** along each side of the interface. More particularly, the sidewalls **64** stiffen the interface body

in both compression and tension to maintain a fixed distance between the strap attachment points **50** and the heel and toe mating features **34, 36**. In one embodiment, the sidewalls **64** are separate components attached to the mounting ears **66, 68**. In other embodiments, the sidewalls may be integrally formed with the interface body. It is to be appreciated, however, that the interface body **38** may be configured in any suitable manner to achieve a desired degree of stiffness and/or torsional stability, such that sidewalls are not required for all embodiments.

[0076] In a conventional strap binding, the ankle and toe straps are attached to the sidewalls of the binding, and only engage a rider's boot from substantially above the ankle and toe areas. Thus, ankle and toe straps in a strap binding apply forces substantially only in the downward direction to inhibit heel lift and toe lift, respectively, without wrapping around the sides of the boot. Consequently, the ankle and toe straps of a strap binding do not inhibit foot roll within the binding.

[0077] As indicated above, it is desirable to configure the binding system **20** so as to provide the performance of a strap binding with the convenience of a step-in system. Thus, according to one illustrative embodiment of the invention, the mounting ears **66, 68** of the interface body may be configured to mount the straps in a manner similar to a conventional strap binding. In this regard, the mounting ears **66, 68** may provide attachment points **50** for the straps at a height and distance apart similar to a strap binding. As illustrated, the mounting ears **66, 68** may be configured to locate the attachment points **50** for the straps in close proximity to the portions of the sidewalls of the binding base where similar straps would be directly attached to the base of a strap binding. This results in forces exerted by a rider on the straps being transmitted to mounting locations similar to a strap binding. The particular configuration and/or location of the mounting ears, however, is not a limitation of all embodiments of the present invention as any suitable configuration or arrangement may be implemented to mount the straps to the interface body.

[0078] The interface **24** may be formed from any suitable material or combination of materials to achieve a desired combination of strength, stiffness, weight and the like. For example, the interface body **38** may be formed from a substantially rigid material, such as aluminum, titanium, glass-filled nylon, polycarbonate, thermoplastic polyurethane and the like. The interface mating features **34, 36** will be subjected to significant lifting forces during riding. Thus, it may be desirable to form the mating features from a relatively strong material. For example, the toe and heel mating features may be formed from stainless steel, hardened steel, hardened aluminum or the like to withstand the anticipated lifting forces. It is to be appreciated, however, that the particular materials employed for the interface body and/or mating features may be chosen to achieve any desired performance characteristics.

[0079] As indicated above, the interface **24** may be configured as a universal device that may be employed with any snowboard boot. This feature of the present invention is advantageous in that through the use of such a universal interface, any boot can be made compatible with a step-in binding, simply by employing the interface and compatible step-in base of the binding system as described herein. In

this manner, a rider can use a boot alone with a strap binding, or the same boot can be used with any of a plurality of different step-in bases by simply employing different interfaces compatible with the desired step-in bases. In other embodiments, the interface may be employed with a boot that has been specifically configured to mate with the interface.

[0080] As is to be appreciated, the interface **24** provides a rider with the ability to readily disengage the boots from the binding which may be extremely convenient. For example, a rider may wish to disengage the rear boot from the binding base when advancing along the slope or in a lift line. When it is desired to re-engage the rear boot, the rider can simply step into the binding base, which thereafter engages the interface and secures the boot to the snowboard. In this manner, the interface provides the rider with the convenience of a step-in system, while simultaneously providing the riding performance characteristics of a conventional strap binding due to the use of binding straps to retain the boot to the binding base through the interface. When the rider wishes to get out of the bindings for an extended period, the boots may be disengaged by releasing the straps and stepping out of each binding, similar to a conventional strap binding, with the interface remaining coupled to the binding base.

[0081] In another illustrative embodiment shown in **FIGS. 7-10**, a binding interface **224** may be provided that is similar in many respects to the embodiment of **FIGS. 1-4**. The interface **224** includes an interface body **38** having a generally hourglass or X shape, similar to the embodiment of **FIGS. 1-4** discussed above. In this regard, the interface body **38** includes generally U or V-shaped front and rear edges **54, 56** that converge toward each other as the edges extend inwardly from the medial and lateral sides of the interface. This results in a lack of material below the toe and heel regions of the boot, to enable boot contact with the base to enhance the feel of the binding system to that of a strap binding. The interface also includes sidewalls **64** that are integral with the lower portion of the interface body to enhance the overall stiffness of the interface. A heel strap (not shown) may be mounted to the medial and lateral sides at the heel end of the interface.

[0082] The interface **224** includes a pair of circular pins **34** extending outwardly from the sidewalls at the heel end of the interface body. The interface also includes a pair of lugs **36** extending outwardly from the sidewalls at the toe end of the interface body. The pins **34** and lugs **36** are adapted for engagement with the binding base discussed below.

[0083] As illustrated in **FIGS. 8-9**, the toe lugs **36** have a generally tear drop shape with a curved outward facing cam surface **48** configured to cam or wedge corresponding engagement members **32** (described below) of the binding base open upon stepping into and out of the binding. Similar to the tapered lugs in the embodiment of **FIGS. 1-5** described above, the cam surface **48** is tapered in the vertical direction (**FIG. 9**) and the longitudinal direction (**FIG. 10**) to provide the desired wedging action. In contrast to the oval shaped of the lugs in the embodiment of **FIGS. 1-5**, the tear drop-shaped lugs employ less material to reduce the weight of the toe lugs. As indicated above, however, any suitable configuration may be employed for the interface heel and toe mating features, including configurations to mate with a different type of binding base than that shown in the figures.

[0084] The interface **224** also includes a pair of mounting ears **66, 68** for mounting ankle and toe straps (not shown) at the heel and toe ends of the interface body. The upper portion of each mounting ear includes a strap attachment point **50** for attaching a strap. The mounting ears may be adjustably supported by the interface body to selectively locate the strap attachment point **50** for the straps.

[0085] In the illustrative embodiment of **FIGS. 7-8**, the mounting ears **66, 68** are rotatably mounted to the interface body about pivots **70** so that the ears may be oriented at a selected angular position to adjust the strap attachment points. A locking arrangement may be employed to retain the mounting ears in the selected orientation. For example, a detent arrangement **72** may be employed between a lower portion of each mounting ear and the interface body. It is to be appreciated, however, that adjustable mounting ears are optional, and are not needed for all embodiments.

[0086] The illustrated binding interfaces described above were described merely for illustrative purposes, as numerous other suitable interfaces may be employed with the binding system.

[0087] As discussed above, the interface **24, 224** is not limited to use with any particular mating features **34, 36** for engaging with a step-in binding base. However, one illustrative embodiment of a binding base suitable for use with each of the illustrative configurations of the interface **24, 224** is shown in **FIGS. 1-4**. It is to be appreciated, however, that other embodiments of the binding system are not limited to use with a strap-mountable interface, as the binding base may be employed to secure a snowboard boot having corresponding mating features provided directly on the boot.

[0088] The binding base **22** includes a baseplate **74** that is configured to be mounted to a snowboard using any suitable arrangement, such as a hold down disc **76**. A strapless engagement mechanism is provided to secure an interface **24, 224** to the binding base **22**. As explained, the interface can be coupled to the base in any number of numerous ways.

[0089] The binding includes a highback **78** to provide a rider with heel side support for placing the snowboard on edge for a heel side turn. A heel hoop **80** may be provided at the heel end of the baseplate to be engaged by the highback and to transmit forces applied to the highback to the snowboard. Alternatively, in other embodiments, the highback can be mounted on the interface or boot, or built into the boot.

[0090] It should be appreciated that providing the highback **78** on the binding may be more advantageous than providing the highback on the binding interface. For example, a binding interface that is free of a highback is likely to be more comfortable for walking or advancing a board along snow to negotiate a lift line. An interface without a highback generally is lighter compared to an interface having a highback. An interface without a highback may also allow a rider to walk or scoot with a more natural gait as compared to an interface with a highback in which the rider's leg would be held in a forward lean position that, although desirable for riding, may be awkward for walking or scooting. Locating the highback on the binding provides a rider with heel side support only when it is typically desired, when the rider is secured to the board within the binding.

[0091] The highback 78 may be mounted to the baseplate 74 for rotation about an axis that is substantially normal to the snowboard to allow a rider to adjust the position of the highback relative to the board edge. In one embodiment, the highback 78 is mounted to the heel hoop 80 using a suitable fastener 82, such as a screw or a tool-free fastener, that extends through an elongated slot 84 on the heel hoop. It is to be appreciated, however, that any suitable arrangement for highback rotation may be implemented, such as employing a series of spaced holes along the heel hoop 80, or other portion of the baseplate, for mounting the highback 78 at desired degrees of rotation. It is to be appreciated that the highback need not be mounted for rotation about the normal axis in all embodiment of the binding base.

[0092] In the illustrative embodiment of FIGS. 1-4, the strapless engagement mechanism includes a pair of engagement members 30 at the rear or heel end of the baseplate 74 and a pair of engagement members 32 at the front or toe end of the baseplate 74 that are configured to engage with the corresponding mating features 34, 36 of the binding interface 24, 224. As shown, each of the pairs of engagement members is provided along the opposing sidewalls of the baseplate. It is to be understood, however, that the binding engagement members may be provided at any desired portion of the binding baseplate suitable for engaging with the corresponding mating features of the interface.

[0093] As indicated above, the binding system 20 is configured to provide the convenience of a step-in binding with the riding performance of a strap binding. To that end, the binding 22 may employ one or more engagement members that are configured to operate in a step-in manner. In the illustrative embodiment shown in FIGS. 1-4, the pair of forward or toe engagement members 32 and the pair of rear or heel engagement members 30 are both configured to operate in a step-in manner. To couple the interface with the binding, as shown in FIG. 4, the toe mating features 36 may be either drawn in a rearward direction, as indicated by arrow A₁, or stepped in a downward direction, as indicated by arrow A₂, into engagement with the toe engagement members 32, and the heel mating features 34 may be stepped in a downward direction, as indicated by arrow A₃, into engagement with the heel engagement members 30. The sequence of engaging the interface to the binding base is not a restriction on the present invention, as the toe mating features 36 may be engaged with the binding base before, after, or at approximately the same time as the heel mating features 34 are engaged with the binding base.

[0094] In the illustrative embodiment shown in FIGS. 1-4, the binding base employs active toe engagement members 32 which are movable to secure and release the toe mating features 36 of the interface. Actuation of the toe engagement members is accomplished without the use of a handle, button or like actuator, thereby resulting in an automatic toe binding mechanism. In this regard, the binding system employs a toe binding mechanism using an automatic actuation principle similar to that described in commonly owned U.S. Pat. No. 6,099,018. It is to be appreciated, however, that not all embodiments of the binding base are limited to an active mechanism, as non-movable toe engagement members may be employed.

[0095] In the illustrative embodiment of FIGS. 1-4, the toe engagement members 32 are movably supported on the

baseplate 74 between an open or release position to allow the toe mating features to be stepped downwardly into or upwardly out of the binding base and a closed or locked position to engage and secure the toe mating features within the binding base. The toe engagement members 32 include a pair of opposing hook-shaped clips that are configured to move toward and away from each other as they are moved toward the closed and open positions, respectively. In one embodiment, the toe clips 32 are configured to independently move toward and away from each other in the lateral or side-to-side direction 86, as shown in FIG. 5, to facilitate stepping into and out of the binding base. In the illustrative embodiment of FIGS. 1-5, the toe clips 32 are configured to slide in the side-to-side direction 86, although any suitable arrangement may be employed with the binding.

[0096] In one illustrative embodiment, as shown in FIG. 5, each toe clip 32 may be urged inwardly towards its closed position with a biasing element 88 disposed between the toe clip 32 and an outer wall 90 of the binding. In this regard, the biasing element 88 may be configured to maintain the toe clips 32 in the closed position with a desired amount of preload on the clips. A stop 92 may be provided to limit the amount of inward deflection of the toe clip under the influence of the biasing element.

[0097] The biasing element 88 may include a resilient pad, such as elastomeric pad, placed between the toe clip 32 and the outer wall 90. The pad may also be configured to prevent an accumulation of snow, ice or other debris between the toe clip and outer wall that could otherwise affect operation of the toe clip. It is to be appreciated, however, that other biasing elements may be employed with the toe clips, including a spring or other arrangements.

[0098] As indicated above, in one illustrative embodiment of the invention, the toe engagement members 32 may include a pair of opposing hook-shaped clips that are movable toward and away from each other. As illustrated in FIG. 4, each clip 32 may include an upper hook portion 94 that is configured with an inclined engagement surface 96 that slopes in a downward direction toward the heel end of the binding, such that the height of the engagement surface 96 above the baseplate 74 is greater at the front side of the clip than at the rear side of the clip. The inclined engagement surface 96 cooperates with the toe mating features 36 of the interface to produce a point contact therebetween to secure the forward end of the interface to the binding base.

[0099] The upper hook portion 94 cooperates with the contoured shape of the toe mating features 36 in a wedging or camming manner to automatically open the toe engagement members 32 as the toe end of the interface is stepped into the binding base and the heel end of the interface is lifted out of the binding base. As described above, the toe mating features 36 include a cam surface 48 (FIGS. 5a and 9-10) that is tapered in both the vertical direction (top-to-bottom) and the longitudinal direction (toe-to-heel).

[0100] The vertical taper results in an overall width between the opposing cam surfaces 48 that decreases in a direction from an upper portion of the mating features toward a lower portion of the mating features. As the toe end of the interface is stepped downward onto the toe engagement members 36, the lower portions of the cam surfaces 48 progressively wedge apart the upper hook portions 94 of the clips until the lugs are seated below the engagement surfaces

96. Once the lugs are positioned below the upper hook portions, the clips return to their closed positions under the biasing force of the biasing elements 88 to secure the toe end of the interface in the binding base.

[0101] The longitudinal taper results in an overall width between the opposing cam surfaces 48 that decreases in a direction from the front portion of the toe mating features toward a rear portion of the toe mating features. As the heel end of the interface is lifted out of the binding base, the rear portions of the cam surfaces 48 progressively wedge apart the upper hook portions 94 of the clips until the toe lugs are released from the toe clips. Once the interface is removed from the binding base, the toe clips return to their closed positions under the biasing force of the biasing elements 88 for receiving the interface within the binding base.

[0102] In an alternate embodiment shown in FIG. 11, the toe mechanism 100 includes a leaf spring 102 arrangement that underlies and extends across the width of the toe region of the base. A pair of toe engagement members 32 in the form of hook-shaped toe clips are attached to the opposing ends of the leaf spring 102 to be moved in a pivoting manner between open and closed positions in response to a rider stepping into and out of the binding. Each toe clip includes a contoured camming surface 104 that is configured to be engaged and driven apart in a lateral direction by the toe mating features 36 as the interface is stepped into the binding. In a manner similar to the embodiment of FIGS. 1-5 described above, the toe clips 32 are also configured to be wedged apart by the toe mating features 36 as the heel end of the interface is lifted out of the binding.

[0103] The toe clips 32 of FIG. 11 have a symmetrical configuration that allows the binding to employ the same toe clip on both sides of the leaf spring for convenience and reduced manufacturing costs. The leaf spring 102 may be formed with upstanding endwalls 106 on which the toe clips are mounted for movement in the lateral direction. The endwalls 106 may be angled inwardly towards each other to preload the toe clips 32 toward the closed position. In one embodiment, the leaf spring 102 is formed from a spring steel, although it may be formed from any suitable material including, but not limited to, stainless steel.

[0104] The configurations of the toe engagement members 32 and the toe mating features 36 achieve an automatic toe locking mechanism that allows a rider to readily step into and out of the binding base without the need to manually actuate a release mechanism for the toe mechanism.

[0105] Having described several embodiments of a toe mechanism for securing the toe end of the interface 24 to the binding 22, it should be understood that any suitable toe binding mechanism may be employed with the binding system. In this regard, while an automatic, active arrangement may provide one or more advantages, the binding system is not limited in this respect. For example, the toe mechanism may be coupled to a release mechanism in which the rider manually actuates the toe mechanism to the open and/or closed positions. Alternatively, the toe mechanism may be configured as a non-active arrangement in which the engagement members are non-movable and fixed relative to the binding such that the toe mating features 36 may be moved in a toe-to-heel direction into and out of engagement with the binding by the rider.

[0106] One illustrative embodiment of a rear or heel locking mechanism for releasably engaging the rear or heel

mating feature of the interface will now be described with reference to FIGS. 1-4 and 12-16. Although the illustrative heel locking arrangement provides a number of advantages as discussed below, it should be appreciated that the present invention is not limited in this respect, and that numerous other heel locking arrangements for engaging with the heel mating features are possible.

[0107] In the embodiment shown, the rear locking mechanism includes a pair of engagement members 30 movably supported on the medial and lateral sides of the binding base. In the illustrative embodiment, the engagement members include a pair of engagement cams 30 that are rotatably supported along the sidewalls of the baseplate. Each cam 30 has a receptacle 110 (FIG. 14) that is configured to receive the heel mating feature of the interface. In the illustrative embodiment, the receptacle 110 is configured as an elongated slot adapted to receive a laterally extending pin 34 from the heel end of the binding interface.

[0108] In the illustrative embodiment, the heel mechanism includes a guide 112 on each side of the binding baseplate to facilitate alignment between the engagement pin and the corresponding engagement cam. The guide 112 includes a rearward facing ramp surface 114 (FIG. 4) that is inclined rearwardly and downwardly toward the heel end of the binding. As the rider steps down into the binding, the guide 112 draws the engagement pin back along a rearwardly extending path toward the heel end of the binding and into the receptacle 110 of the engagement cam 30, which is aligned with the guide when the engagement cam is placed in the open position.

[0109] In the illustrative embodiment, the engagement cams 30 are biased to the open position so that the pin receptacles 110 are oriented in an upwardly facing direction to receive the mating pins 34 being stepped into the binding in a downward direction. In one embodiment, the cams 30 are continuously biased to the open position (counterclockwise as shown by arrow B₁ in FIG. 14) using a spring 116, such as a torsion spring disposed about a mounting shaft 118 for the cam. The engagement cams are rotatably mounted about a common transverse axis 120 (FIG. 12) with the engagement cams being parallel to each other to facilitate operation of the heel mechanism. It is to be appreciated, however, that the present invention is not limited to the cams being parallel to each other and/or rotatable about a common axis, as the cams may be mounted along separate axes that may or may not be parallel to each other.

[0110] As shown in FIG. 4, the rider can simply step into the binding base by aligning the toe mating features 36 with the forward or toe engagement members 32 on the interface and stepping downwardly so that the toe mating features step into the toe clips and the rear engagement pins 34 are guided by the ramp 114 into the pin receptacle 110 of the engagement cam. As the rider steps further into the binding, engagement between the pin 34 and the lower portion of the cam receptacle 110, which is offset from the cam shaft 118 in a rearward direction, causes the cam to rotate in a rearward direction about the shaft (clockwise in FIGS. 3-4) to a closed position (FIG. 3), where the cam is locked, as discussed below, to secure the pin to the binding base. Alternatively, the cams 30 may be configured with the receptacle 110 offset from the cam shaft 118 in a forward direction so that the cams rotate in a forward direction about the shaft to a closed position.

[0111] It should be appreciated that the rearwardly-extending guide 112 is also advantageous because movement of the engagement pin 34 along the guide causes the rider's boot to be drawn rearwardly as the rider steps into the binding base. This causes the rear portion of the boot 26 to advantageously be seated firmly against the heel hoop 80 and highback 78, thereby enabling efficient force transmission between the highback and the boot. This motion positions the forward mating features 36 relative to the forward engagement members 32 to ensure proper engagement by the toe mechanism. It should be understood that the present invention is not limited to the particular guide shown in the figures, as other geometries for a guide are possible to align the interface 24 with the binding 22 and to draw the interface rearwardly into the locked position shown in FIG. 3. In other embodiments, a rearwardly-extending guide need not be employed with the binding base.

[0112] In the illustrative embodiment, each engagement cam 30 is rotatably supported by the binding base independently of the other cam. In this manner, each cam 30 may be moved between its open and closed positions independently of the position of the other cam. This may facilitate stepping into and out of the binding base 22 by allowing some misalignment between the interface 24 and binding base 22 as the rider steps into and out of the base. For example, the independent cams 30 may allow a rider to step into or out of the binding base 22 with the interface 24 cocked or angled relative to the lateral and/or medial sides of the base. Although advantageous, it is to be understood that the engagement cams 30 do not need to be mounted for independent rotation in all embodiments of the invention, as the engagement cams 30 alternatively could be coupled to each other for rotation between the open and closed positions.

[0113] In the illustrative embodiment shown in FIGS. 14-17, a locking catch 122 is movably supported between an open or release position (FIG. 16) and a closed or locked position (FIG. 15) adjacent the engagement cam to secure the cam in its closed position. The engagement cam 30 includes at least one locking feature 124 that is configured to be engaged by the locking catch 122 when the cam and locking catch are both moved to their locking positions to secure the cam in the locked position. In the illustrative embodiment, the locking catch 122 is rotatable from its open position and to its closed position to engage the cam locking feature 124.

[0114] To facilitate operation of the heel mechanism, each locking catch 122 is continuously biased (in the direction of arrow C₁) to engage with the engagement cam 30 so that the heel mechanism is automatically actuated into a locked configuration upon rotation of the engagement cam to its closed position to secure the interface to the binding base. A torsion spring 126 (FIG. 14), or other suitable biasing arrangement, may be employed to load the locking catch 122 to its closed or locked position relative to the engagement cam.

[0115] In one embodiment, the binding system is configured to accommodate an accumulation of snow between the interface/boot and the binding base. In the illustrative embodiment, the heel mechanism is configured with a plurality of locking positions for accommodating varying amounts of snow accumulation on the surface of the base-plate or within the heel mechanism. As shown, the engage-

ment cam includes a plurality of locking features 124, such as locking teeth, that cooperate with the locking catch 122 in a ratchet-and-pawl arrangement. In this manner, the engagement cam 30 may close and secure the engagement pin 34 within any one of a number of locked positions depending upon the amount of snow, ice and/or other debris that may accumulate between the boot and binding base. In this regard, each engagement cam 30 may secure an engagement pin 34 anywhere from a partially closed position (FIG. 15) to a fully closed position (FIG. 16). The amount and degree of cam adjustability may be varied by the number of and pitch between the locking teeth 124 on the engagement cam 30.

[0116] The ratcheting arrangement is advantageous in that it allows each engagement cam 30 to continuously and automatically adjust itself toward the fully closed position (FIG. 16) as the accumulation of snow, ice or other debris diminishes between the boot and binding base. For example, as snow and/or ice melts or becomes compressed under the weight of a rider, a downward force exerted by the engagement pin 34 on the engagement cam 30 will further rotate the cam toward its fully closed position, while the locking catch 122 acts as a pawl to prevent the engagement cam 30 from rotating to its open position (FIG. 14) in response to an upward force by the engagement pin on the cam. Additionally, independent rotation of the cams 30, as described above, allows the heel mechanism to accommodate different amounts of snow accumulation on both sides of the binding.

[0117] Although advantageous, it is to be understood that a locking arrangement employing multiple locking positions for accommodating snow accumulation does not need to be employed with all embodiments of the present invention. Further, even should it be desirable to accommodate an accumulation of snow, ice or other debris between the boot and binding, it is to be appreciated that other suitable arrangements alternatively may be employed with the heel mechanism and/or toe mechanism of the binding to accommodate such accumulations.

[0118] The locking catches 122 may be coupled to a single or separate actuators to allow the rider to release the heel mechanism from its locked position so that the engagement pins of the interface may be removed from the binding. In one illustrative embodiment shown in FIG. 12, the locking catches 122 are coupled to a single release lever 128 using a common shaft or link 130 that extends transversely across the binding between the catches. This arrangement is configured to directly drive the catches 122 from the locked position to a release position upon actuation of the lever by the rider.

[0119] In one embodiment, a locking feature is employed to lock the release lever to prevent an inadvertent release of the heel mechanism. For example, a detent arrangement (not shown) may be implemented to prevent inadvertent movement of the lever 128. As another example, a biased lock out button (not shown) may be located adjacent the lever to prevent lever movement until the lock out button is actuated by the rider. It is to be appreciated that the detent and lock out button arrangements are merely exemplary and that any suitable arrangement may be employed for avoiding inadvertent release. Additionally, a locking feature for the lever does not need to be employed in all embodiments.

[0120] Each end of the shaft 130 may be configured with a pair of opposing flats 131 (FIG. 15) that cooperate with a

corresponding recess in the catch **122** so that rotation of the shaft **130** is transmitted to the catches with little or no rotational slip between the catch and shaft. It is to be appreciated that numerous other configurations may be employed to couple the catches **122** to the shaft **130** so as to minimize rotational slippage therebetween. For example, the shaft may have a hexagonal shape that cooperates with a hexagonal recess in each catch.

[0121] While a common shaft **130** provides a relatively simple release arrangement for the catches, it is to be understood that any suitable arrangement may be employed to release the catches from the engagement cams. For example, the catches **122** may be coupled to separate actuators. Additionally, rather than attaching the lever **128** directly to the shaft **130**, a linkage may be employed between the lever and shaft to allow the lever to be located to any desired position.

[0122] In one embodiment, the heel mechanism includes a cocking mechanism that is configured to maintain the catches in the release position so that the rider is not required to manually hold the catches in the release position while simultaneously stepping out of the binding. In one illustrative embodiment shown in **FIGS. 14-17**, the cocking mechanism includes a lockout latch **132** that is configured to cooperate with the locking catch **122** in a manner that maintains the catch in its released position to allow rotation of the engagement cam **30** towards the open position to release the engagement pin **34** from the heel mechanism. The lockout latch **132** is rotatably supported about a pivot **134** between a nose or first end **136** of the latch and a tail or second end **138** of the latch. In the illustrative embodiment, the lockout latch **132** is continuously biased toward a lockout position (counterclockwise in the direction of arrow D_1 in **FIGS. 14-17**) so that the latch automatically assumes the lockout position when the catch is placed in its release position. Since the locking catches **122** are coupled to each other, it may be desirable to employ a lockout latch **132** with only one of the catches, although it is to be appreciated that a lockout latch may be employed with each catch.

[0123] In the illustrative embodiment, the nose end **136** of the latch is configured to cooperate with a detent **140** provided on the lower end of the catch **122** to either maintain the catch in the release position or maintain the lockout latch in a neutral position depending upon the desired state of the heel mechanism. As shown in **FIG. 15**, when the catch **122** is in its locking position to maintain the engagement cam **30** in one of its closed positions, the detent **140** of the catch is positioned below the nose **136** of the lockout latch to maintain the latch in a neutral, non-lockout position. As shown in **FIG. 16**, when the catch **122** is rotated (in the direction of arrow C_2) to its release position by the rider, the lockout latch **132** rotates (counterclockwise D_1 in **FIG. 16**) to its lockout position with the nose end **136** of the latch positioned below the detent **140** of the locking catch. When the rider releases the lever, the lockout latch **132** engages the catch in a notch **142** below the detent to prevent the locking catch **122** from returning to its locked position such that the engagement cam **30** may be freely rotated (counterclockwise B_1 in **FIG. 14**) to its open position as the engagement pin is lifted from the heel mechanism.

[0124] The heel mechanism may be configured to be automatically reset when the engagement cam **30** is placed

in the open position. In the illustrative embodiment of **FIGS. 14-17**, the engagement cam **30** includes a trigger **144** that is configured to reset the lockout latch **132** to its neutral position above the detent so that the locking catch **122** may return to a neutral position as shown in **FIG. 14**. As illustrated in **FIG. 17**, the trigger **144** is provided along the perimeter of the engagement cam **30** below the locking teeth **124** so that the trigger engages with the tail end **138** of the lockout latch as the engagement cam is rotated (counterclockwise B_1 in **FIG. 17**) to a position in which the locking catch **122** is unable to re-engage with the locking teeth **124** of the cam. Continued rotation of the engagement cam **30** toward the open position causes the lockout latch **132** to rotate (clockwise D_2 in **FIG. 17**) toward its neutral position above the detent **140**, thereby allowing the locking catch **122** to assume its reset, neutral position against the cam.

[0125] The heel mechanism may employ any suitable cocking arrangement to maintain the catches **122** or other elements in a release position. For example, the cocking mechanism may include a cantilevered lockout, rather than the illustrated rotatable lockout. One such arrangement is described in more detail below.

[0126] As described above, the engagement cams of the heel mechanism are supported for independent movement relative to each other between the open and closed positions. It may be desirable to configure the heel mechanism so that neither engagement cam **30** may be locked by its respective locking catch **122** until both engagement cams **30** are placed in a closed position. Such an arrangement may be advantageous in avoiding a false locking condition in which only one of the engagement cams is closed and locked to secure the binding interface to the binding base.

[0127] In one illustrative embodiment shown in **FIGS. 14-17**, the incidence of a false locking condition may be reduced with an arrangement in which each locking catch **122** is maintained in a neutral, non-locked position (**FIG. 14**) until both engagement cams **30** are actuated to a closed position (**FIG. 15**). As illustrated, each engagement cam **30** is configured with a neutral region **146** (along the perimeter of the cam above the locking teeth **124**) which is configured to be engaged by the locking catch **122** when the cam **30** is in its open position or a neutral position in which the cam is rotated between its open position (**FIG. 14**) and its initial closed position (**FIG. 15**). When either of the engagement cams **30** is in the neutral position such that its corresponding locking catch **122** is similarly maintained in the neutral position against the neutral region **146** of the cam, the other locking catch is also maintained in the neutral position, even when its corresponding cam is in a closed position, due to the coupling of the locking catches through the shaft **130**. Thus, only when both engagement cams **30** are placed in a closed position (**FIG. 15**) will each of the locking catches engage any one of the locking teeth **124** on a corresponding cam to lock the cam in one of the closed positions.

[0128] It is to be appreciated that the heel mechanism may employ numerous other suitable arrangements to prevent one cam from locking if the other cam is not prepared to lock. In this regard, it is not a limitation of all embodiments to couple the locking catches together. Additionally, other embodiments of the heel mechanism do not need to employ an arrangement to prevent a false locking condition.

[0129] Operation of the illustrative embodiment of the heel mechanism shown in **FIGS. 1-4** will now be described

in connection with FIGS. 14-17. With the engagement cams 30 placed in their open position as shown in FIG. 14, the engagement pins 34 on the interface may be introduced in a downward direction A_3 into the heel mechanism. Each pin 34 is directed by the guide 112 in a rearward and downward direction into the pin receptacle 110 of the engagement cam. Continued downward movement of the engagement pin as the rider steps into the binding rotates the engagement cam (clockwise B_2 in FIG. 15) toward a closed position.

[0130] When each of the engagement cams 30 is rotated to at least an initial closed position as shown in FIG. 15, each locking catch 122 rotates (clockwise C_1) into engagement with one of the locking teeth 124 of its corresponding cam. Continued downward movement of the pin 34 further rotates the cam 30 in a ratcheting manner toward a fully closed position, as shown in FIG. 16. It is to be appreciated that any accumulation of snow, ice or other debris between the boot and binding base may result in one or both engagement cams 30 being placed in the initial closed position (FIG. 15) or an intermediate closed position anywhere between the initial closed position and the fully closed position (FIG. 16). Further, either engagement cam 30 may automatically move toward the fully closed position independently of the other cam as any accumulation of snow, ice or other debris is reduced between the boot and binding base.

[0131] When it is desired to release the engagement cams 30 to allow a rider to remove the interface from the heel mechanism, the rider actuates the release lever 128 (FIG. 12) to disengage each of the locking catches 122 from its corresponding cam 30 by rotating the catch from its locked position to its release position (FIG. 16). When the locking catches 122 are placed in the release position, the lockout latch 132 rotates in the direction of arrow D_1 from its neutral position to the lockout position (FIG. 16) to engage the locking catch in the notch 142 below the detent. In this manner, each locking catch 122 is maintained in a cocked, release position when the rider releases the lever. The rider can thereafter step out of the heel mechanism whenever convenient without being required to hold the release lever while simultaneously stepping out of the heel mechanism.

[0132] With the locking catches 122 being maintained in the cocked, release position, the binding interface may be removed from the heel mechanism by lifting the heel end of the interface in an upward direction. As the interface is lifted from the heel mechanism, each engagement pin 34 is raised in an upward direction along the guide 112, thereby allowing the engagement cam 30 to rotate (counterclockwise B_1 in FIG. 17) toward its open position. When the cam reaches its neutral position, the trigger 144 engages with and rotates the lockout latch 132 (clockwise D_2 in FIG. 17) to its neutral position, thereby releasing the locking catch 122 from its cocked, release position, and enabling the locking latch 122 to move to its neutral position in engagement with the neutral region 146 of the cam as shown in FIG. 14. Thus, removing the binding interface from the binding base automatically resets the heel mechanism for subsequently receiving and securing the binding interface in the binding base.

[0133] It may be desirable to provide an indicator that is configured to indicate to a rider that the heel mechanism has been actuated to its closed position to secure the interface to the binding base. The indicator may include one or more visual and/or audible indicators. For example, each engage-

ment cam may include a visual indicator that is configured to indicate to the rider that the cam has been rotated to any one of its closed positions. In one embodiment, a portion of the peripheral edge 148 of the cam between the receptacle and the locking teeth is provided with a contrasting color that becomes visible to the rider when the cam is rotated to at least the initial closed position as shown in FIG. 15. The indicator may be visible through the entrance to the guide 112 or a separate window adjacent the peripheral edge of the cam. It is to be appreciated, however, that any suitable indicator, may be employed with the heel and/or toe mechanism of the binding, or an indicator need not be employed at all.

[0134] In another illustrative embodiment schematically shown in FIGS. 18-19, a heel mechanism is provided that is similar in many respects to the embodiment described above. The heel mechanism includes a pair of engagement cams 30 that are rotatably supported by the binding base independently of each other for movement between their open and closed positions. Each cam 30 is configured with a receptacle 110 that is adapted to receive the corresponding mating feature, such as a pin, of the interface. The cams 30 are arranged to rotate along a common transverse axis 120 with the cams being parallel to each other, although the cams may be mounted along separate axes that may or may not be parallel. The cams 30 are biased to the open position with a spring 116, such as a torsion spring.

[0135] A locking catch 122 is movably supported adjacent each cam 30 between an open or release position and a closed or locked position to engage a locking feature, such as a locking tooth 124, on the cam. The locking catch 122 is biased to the locked position with a torsion spring 126 or other suitable biasing arrangement. To accommodate an accumulation of snow, ice or other debris between the boot/interface and binding base, the catch 122 may engage any of a plurality of locking teeth 124 on the cam 30 in a ratchet-and-pawl arrangement in a manner similar to that described above.

[0136] The locking catches 122 are coupled to each other with a common shaft 118 or link that extends transversely across the binding parallel to the rotational axis 120 of the cams. A lever 128 is provided at one end of the shaft 118 to allow a rider to actuate the catches to the open position. As shown, the shaft 118 has a hexagonal shape that cooperates with a hexagonal recess in each catch 122 to minimize rotational slippage.

[0137] Similar to the mechanism described above, a cocking mechanism may be employed to maintain the catches in the release position so that a rider is not required to manually hold the catches in the release position while stepping out of the binding. In this illustrative embodiment, the cocking mechanism includes a cantilevered lockout 150, such as a cantilever spring, that is biased to a lockout position between the catch 122 and the cam 30 when the catch is rotated to its release position. The cam 30 includes a trigger 144 between the locking teeth 124 and its neutral region 146 that is configured to engage the free end of the lockout 150 and push the lockout in a lateral direction E to a neutral position against the side of the cam as the engagement cam is rotated toward the open position to reset the mechanism.

[0138] As indicated above, each engagement cam 30 is biased to the open position such that when the binding interface is removed from the binding base, the engagement

cam will assume its open position, such as shown in FIG. 14. It may be desirable to prevent over-rotation and maintain a pre-load on the cam in the open position so that the cam will not tend to rotate toward the closed position until the interface is stepped into the mechanism. Such an arrangement may facilitate operation of the heel mechanism by ensuring proper positioning of the cams in the open position using a biasing element, such as a spring 116, which exerts a biasing force that would otherwise over-rotate the cams. Alternately, the biasing element could be chosen so that it maintains the cam in the open position when the biasing element attains its relaxed, unloaded state.

[0139] In the illustrative embodiment shown in FIGS. 18-19, each cam 30 includes a stop 152 that is configured to be engaged by the locking catch when the cam is rotated to the open position. As illustrated, the cam 30 includes a tooth 152 (along its peripheral edge at an end of the neutral region 146 opposite the locking teeth 124) that is engaged by the locking catch 122 when the cam rotates to the open position. Once engaged, the cam 30 is prevented from over-rotation beyond the open position which may otherwise occur due to the biasing force of the spring. It is to be understood that any other suitable arrangement alternatively may be implemented to maintain each cam in the open position ready to accept the binding interface.

[0140] Each cam may be configured with a peripheral edge having a radius that varies between at least the locking teeth 124 and the neutral region 146 relative to the rotational axis 120. As illustrated, the tips of the locking teeth may lie along a radius R_1 that is less than the radius R_2 of the neutral region. This stepped arrangement maintains a locking catch out of engagement with the locking teeth of a cam rotated to a closed position until both cams are rotated to a closed position. It is to be appreciated that other embodiments of a heel mechanism do not need to employ a cam having a stepped peripheral edge, as any suitable arrangement may be implemented to prevent one side of the heel mechanism from locking unless and until both sides of the mechanism can lock.

[0141] In a further illustrative embodiment schematically shown in FIGS. 20-22, a heel mechanism may be provided that is similar in many respects to the embodiment described above in FIGS. 18-19. In this embodiment, the heel mechanism also includes a pair of engagement cams 30 that are rotatably supported by the binding independently of each other for movement between their open and closed positions with the cams 30 biased to the open position. A locking catch 122 is movably supported adjacent each cam 30 between an open or release position and a closed or locked position to engage any of a plurality of locking teeth 124 on the cam in a ratchet-and-pawl arrangement to accommodate an accumulation of snow, ice or other debris.

[0142] The locking catches 122 are coupled to each other with a common shaft 118 or link that extends transversely across the binding parallel to the rotational axis 120 of the cams. A lever 128 is provided at one end of the shaft 118 which coacts with a separate release handle 154, which is rotatably supported by the binding, to allow a rider to actuate the catches 122 to their open positions.

[0143] Similar to the mechanism described above, a cocking mechanism may be employed to maintain the catches in the release position so that a rider is not required to manually

hold the catches in the release position while stepping out of the binding. In this illustrative embodiment, the cocking mechanism includes the release handle 154, which is configured with a cam portion 156 that engages with and actuates the lever 128 as the handle is rotated by the rider to a lockout position (FIG. 21). The handle 154 remains in the raised position to maintain the locking catches 122 in the release position when the handle is released to allow the rider to step out of the heel mechanism. The rider may manually reset the heel mechanism by pushing down on the handle 154 (FIG. 22) to allow the lever 128, and consequently the locking catches 122, to return to the locking position.

[0144] The handle 154 may be provided with a cavity 158 that is configured to receive the lever 128 when the handle is rotated to the lowered, locking position. This arrangement reduces the incidence of an inadvertent release of the heel mechanism by securing the lever 128 within the handle 154, while allowing limited movement of the lever 128 within the cavity so that the locking catches 122 may operate in a ratcheting manner. As is to be appreciated, any suitable cocking/actuation arrangement may be implemented with the heel mechanism.

[0145] Having described several illustrative embodiments of a heel mechanism for the binding base, it should be understood that that binding base may employ any number of suitable heel mechanisms. It is also to be appreciated that any suitable cocking mechanism optionally may be implemented with the illustrated heel mechanisms. Additionally, other embodiments of a heel mechanism do not need to employ a cocking mechanism.

[0146] As indicated above, the binding system may be configured to secure snowboard boots of various configurations to a snowboard without requiring any particular modification to the boot. As indicated above, however, it may be desirable for the boot sole to engage the baseplate of the binding. This may be accomplished in any of a number of ways, including several non-limiting examples described below. It is to be appreciated, however, that engagement between the boot sole and the baseplate is not a limitation of all embodiments of the binding system.

[0147] In one illustrative embodiment shown in FIGS. 1-2, the binding 22 may include one or more pads 160, 162 that are configured to receive the interface body 24 in a nesting relationship to facilitate engagement of the boot sole with the baseplate through the pads. The binding may include toe and heel pads 160, 162 that are configured to underlie the toe and heel regions of the boot 26. The pads 160, 162 may be fixed or adjustable relative to the baseplate 74 to allow a rider to selectively position one or both pads to achieve a desired fit or feel. As illustrated, the pads may be shaped to closely conform to the shape of the front and rear edges 54, 56 of the interface body 38. However, any desirable shape may be implemented with the pads.

[0148] In another illustrative embodiment shown in FIG. 23, the interface 24 may include one or more pads 164, 166 attached directly to the lower portion of the interface body 38. The interface may include toe and heel pads 164, 166 that are configured to underlie the toe and heel regions of the boot 26. Engagement between the boot sole and the baseplate 74 is accomplished through the pads when the interface is coupled to the binding base 22.

[0149] As indicated above, although it may be desirable to employ any snowboard boot with the binding system, the interface may be used with a boot specifically configured for use with the binding system. In one illustrative embodiment shown in FIG. 24, a snowboard boot 26 may include a sole 170 having a recess 172 configured to receive the interface body 38 therein such that the interface body does not protrude below the bottom surface of the sole. This configuration ensures that the boot sole 170 is in direct contact with the binding base 22. In the illustrative embodiment, the recess 172 has a generally hourglass or X shape that is compatible with the interface body. It is appreciated, however, that the snowboard boot may be configured with a recess in the sole having any desired configuration that may be compatible with the particular shape of the interface.

[0150] The interface 24 has been described above in connection with a snowboard binding system for securing a snowboard boot to a snowboard. However, it is also contemplated that the interface 24 may be integrated with other equipment or systems for traversing terrain. For example, in addition to a snowboard binding 22, the interface 24 may be configured to be coupled to a snowshoe, a crampon and the like. In this regard a rider may employ the same interface for one or more products that may be used for back country riding in which the rider is typically required to hike, climb and ride across various terrain. The interface may be configured with cleats or similar structures to provide a rider with traction to facilitate hiking and climbing terrain.

[0151] Having described several illustrative embodiments of the invention, various modifications and improvements will readily occur to those skilled in the art. Such modifications and improvements are intended to be within the scope of the invention. Accordingly, the foregoing description is by way of example only and is not intended to be limiting. The invention is limited only as defined in the following claims and the equivalents thereto.

What is claimed is:

1. An interface for coupling a snowboard boot to a snowboard binding base, the snowboard boot including a sole, the snowboard binding base including at least one pair of engagement members, the interface comprising:
 - an interface body including a lower portion that is to be mounted below at least a portion of the sole of the snowboard boot, the lower portion having an X-shaped configuration;
 - at least one pair of mating features supported by the interface body, the at least one pair of mating features to be engaged by the at least one pair of engagement members; and
 - at least one strap supported by the interface body to secure the binding interface to the snowboard boot.
2. The interface according to claim 1, wherein the at least one strap includes first and second straps supported by the interface body.
3. The interface according to claim 2, wherein the first strap includes an ankle strap supported at a heel end of the interface body, the ankle strap being adapted to extend across an ankle portion of the snowboard boot.
4. The interface according to claim 1, wherein the binding interface includes a pair of sidewalls on medial and lateral sides of the interface body, each of the sidewalls extending from a toe end to a heel end of the interface body.
5. The interface according to claim 4, wherein the sidewalls are integrally formed with the interface body.
6. The interface according to claim 1, wherein the lower portion includes medial and lateral sides and front and rear edges extending between the medial and lateral sides, each of the front and rear edges having a U-shaped configuration.

* * * * *