

(12) UK Patent Application (19) GB (11) 2 127 793 A

- (21) Application No 8325206
- (22) Date of filing 21 Sep 1983
- (30) Priority data
- (31) 412722
- (32) 4 Oct 1982
- (33) Canada (CA)
- (43) Application published 18 Apr 1984
- (51) INT CL³
B65H 35/10
- (52) Domestic classification
B8R 4A W1
U1S 1789 B8R
- (56) Documents cited
GB A 2028771
- (58) Field of search
B8R
- (71) Applicant
W. R. Grace & Co.,
(USA—Connecticut),
Grace Plaza,
1114 Avenue of the
Americas,
New York,
New York 10036,
United States of America
- (72) Inventor
Roderick Arnold Bolton
- (74) Agent and/or address for
service
J. A. Kemp & Co.,
14 South Square,
Gray's Inn,
London,
WC1R 5EU

(54) **Method for making partially separated multibags**

(57) A method for making a supply of partially separated multibag units, comprises first passing a perforated chain of side-sealed bags through a first set of driven nip rollers, then passing said chain directly to a second set (55) of nip rollers (57, 63A, 63B)

having a partial nip of selected width less than the width of said chain, while driving said second nip rollers at a speed greater than said first nip rollers sufficient to partially separate the bags at their respective lines of perforation, and while periodically completing the nip of said second nip rollers (at 64A, 64B) at predetermined intervals corresponding to the number of bags desired in each multibag unit.

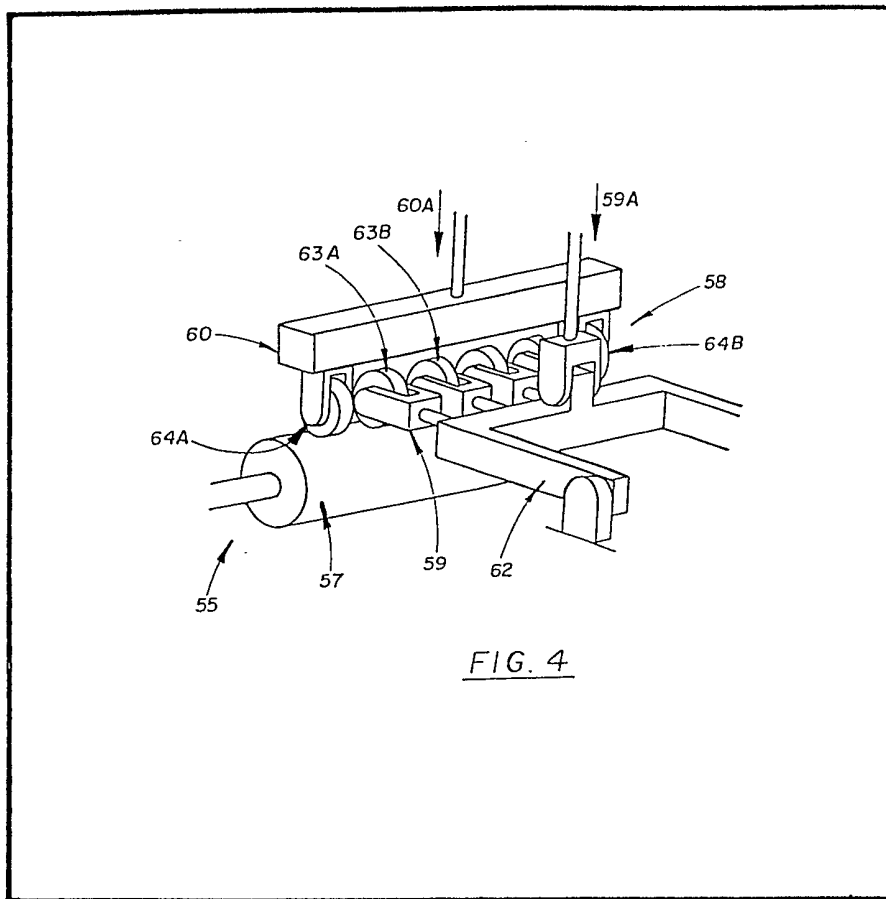

GB 2 127 793 A

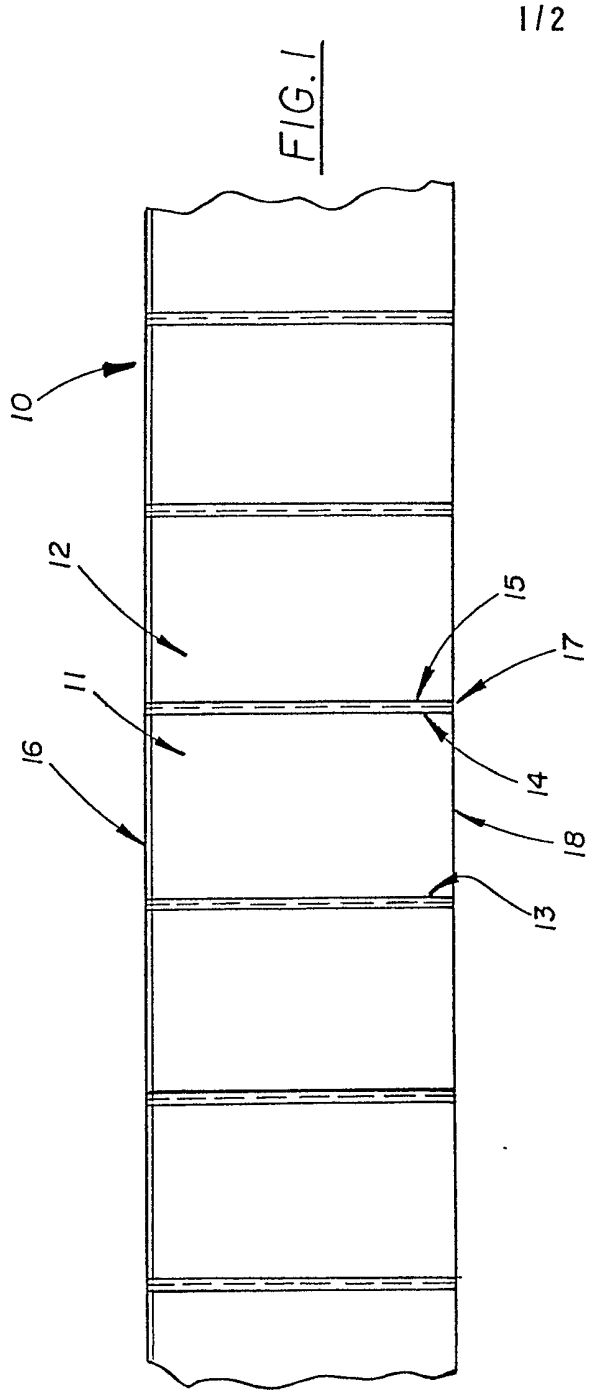

1/2

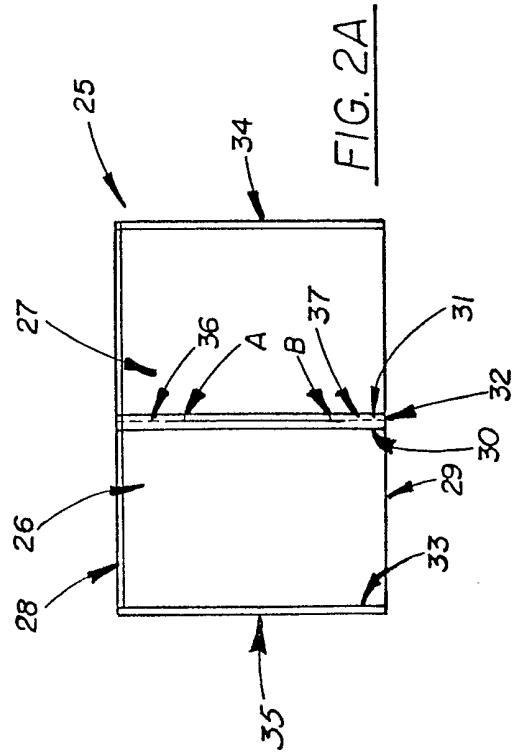
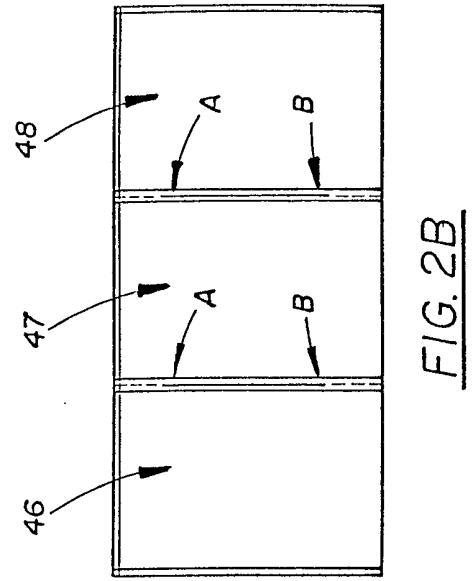

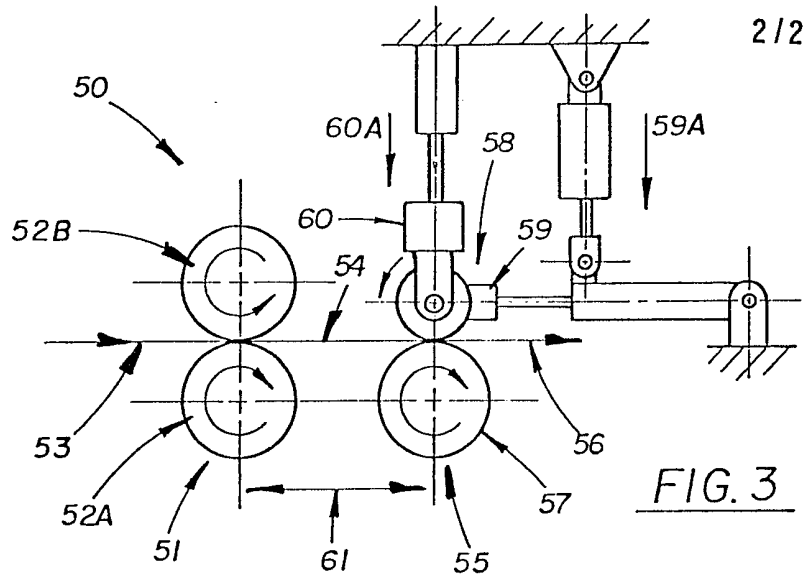

FIG. 3

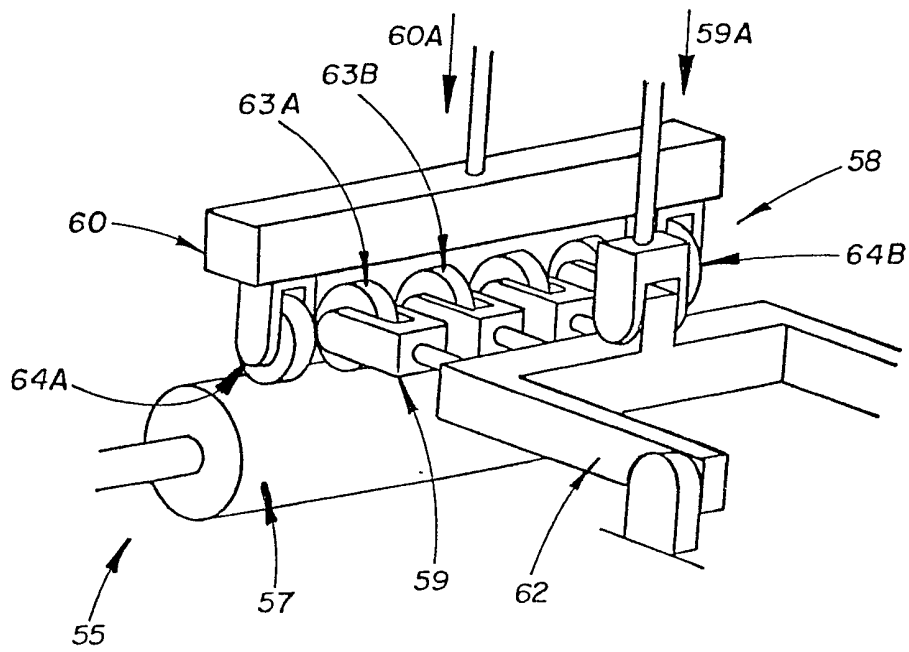

FIG. 4

SPECIFICATION

Method for making partially separated multibags**Background of the invention**

5 This invention relates generally to manufacture of plastic packaging bags. More particularly, this invention relates to separating and partially separating bags within a perforated chain of bags.

10 In the field of packaging articles such as food products, it is known to load the products into plastic bags, and then to seal the bag openings, respectively. It is also known to carry out the sealing operation in a vacuum chamber where the residual atmosphere within the bag can be
15 withdrawn and the package sealed under vacuum conditions in order to avoid deterioration of the food product in the sealed bag.

It is known to load product articles into packaging bags, made of flexible heat shrinkable
20 film material, by supplying bags to a bag loader, in the form of a continuous chain of discrete bags carried releasably on adhesively-coated support tapes. Articles to be packaged are situated at a loading station typically by feeding on a conveyor
25 belt into a guide from which the article is loaded into the leading bag of the chain, after opening of the bag for example by an inflation air jet. The bag loader accepts the bags in shingled or imbricated configuration, and it is then left up to
30 either the operator or some article-advancing means, to remove the top loaded bag from the imbricated bag chain before the next successive bag can be inflated and loaded. Supplying the bags in imbricated configuration in a taped chain offers considerable advantages over supplying the
35 bags one at a time to the loading equipment.

The present invention aims to provide means for making a packaging system which is capable of more rapid and economic operation for loading
40 articles into bags which are fed to a loading station in the form of a sequence of bags. Such system is intended to enable the packaging operation to be speeded up in subsequent vacuumizing and sealing steps as well.

45 U.S. Patents 3,161,347 and 3,331,182 disclose of typical bag loading processes and apparatus and illustrate the use of a chain of bags in imbricated form supported on a continuous support member so that the imbricated bags
50 arrive at a loading station where the uppermost bag is pneumatically inflated and has a product article place therein, after which the bag is removed from its elongate support member and delivered ready for subsequent advance to a bag
55 closing station.

U.S. Patent 3,587,843 discloses a package of
such bags supported on two adhesively coated
tapes to which the bags are releasably attached.
The manufacture of such a package of taped bags
60 requires initially the production of a plurality of separate bags, then the shingling of those bags on a moving delivery conveyor accompanied by superimposition and pressure adhesion of the tapes thereto after which the taped bag supply

65 can be packaged either by being wound up on a support roll or layered into a box. The package of bags, either on a support roll or in a box, or on or in any other suitable holder, can then be transported to a user location where the
70 individual bags will be filled by a bag loader to which the bags are fed as a chain of imbricated bags.

Of general interest is the disclosure of U.K. Patent Application 2,078,654A for "Loading
75 Plastic Bags For Packaging Purposes" published January 13, 1982, directed to a packaging process that utilizes a chain of side-sealed packaging bags with the mouths of the bags facing laterally of the chain of bags. Several of the
80 bags are loaded in a batch, and the bags are subsequently closed in batch-wise fashion.

Of general interest is the disclosure of U.K. Patent Application 2,080,179A for "Apparatus
85 for Separating and Loading Bags of a Chain of Side-Sealed Packaging Bags" published February 3, 1982, directed to a mechanism for separating and loading bags from a perforated chain of side-sealed laterally extending packaging bags, especially in connection with the preceding cited
90 packaging process.

Summary of the invention

The present invention is directed to a method of making a series of multiple-bag units adapted for imbrication on a carrier. Such multibag units
95 may each be handled essentially as a single bag upon sequential presentation to a bag loader, thereby multiplying output from the loader. This handling advantage is also realized in subsequent vacuumizing and sealing operations, further
100 enhancing productivity.

Accordingly, there is provided a method for making a supply of partially separated multibag units, comprising first passing a perforated chain of side-sealed bags through a first set of driven
105 nip rollers, then passing said chain directly to a second set of nip rollers having a partial nip of selected width less than the width of said chain, while driving said second nip rollers at a speed greater than said first nip rollers sufficient to partially separate the bags at their respective lines
110 of perforation, and while cyclically completing the nip of said second nip rollers at predetermined intervals corresponding to the number of bags desired in each multibag unit. Preferably, partial separation of the bags within a multibag unit is symmetric with respect to the bag length.

Also, there is provided apparatus for making a supply of partially separated multibag units, comprising means for passing a perforated chain of side-sealed bags through a first set of driven
120 nip rollers; means for passing said chain directly to a second set of nip rollers, having a partial nip of selected width less than the width of said chain; means for driving said second nip rollers at a speed greater than said first nip rollers sufficient to partially separate the bags at their respective
125 lines of perforation; and means for cyclically completing the nip of said second nip rollers at

predetermined intervals corresponding to the number of bags desired in each multibag unit.

Brief description of the drawings

Further details are given below with reference to the embodiments shown in the drawings wherein:

Fig. 1 shows a conventional perforated series of side-sealed bags which are fed to separator apparatus of the invention;

Figs. 2A, B show representative multibag units having two and three component bags, respectively;

Fig. 3 shows a side view of an embodiment of separator apparatus of the invention; and

Fig. 4 shows a detailed perspective view of the second roll set of the foregoing separator apparatus.

Description of the preferred embodiments

Referring specifically to the drawings, in Fig. 1 a conventional series 10 of perforated side-sealed plastic bags is shown, for example being of indefinite length and made of polyethylene. Bags within the series, such as bags 11 and 12, are separated by a line of perforation 17, with side-seals 14 and 15 on either side of perforation 17. Bag 11, for example, is defined by side-seals 13 and 14, fold line 18 and extended lip opening 16. Such a series of bags may be made by conventional techniques, for example, first extruding a plastic tube, then collapsing said tube to a lay-flat configuration possibly following orientation, cutting along one fold line to form an extended lip opening, and repeatedly forming transverse seals, such as by impulse welding, and lines of perforation at regular intervals along the collapsed tube to create a series of side-sealed bags which open laterally and which are separated by transverse lines of perforation. Such a series of side-sealed bags is the starting material for utilization of the present invention.

In Figs. 2A and 2B, there are shown representative examples of multibag units, for definitional purposes. In Fig. 2A, there is shown a two bag multibag unit 25, having component bags 26 and 27 which have been jointly separated from a chain of perforated side-sealed bags at separated lines of perforation 34 and 35. Bag 26, for example, is as discussed above having extended lip opening 28, fold 29, and side-seals 30 and 33. At the junction between the two bags making up the multibag unit there are side-seals 30 and 31 juxtaposed about line of perforation 32. Line of perforation 32, however, is partially separated as indicated between points A and B. Preferably, partial separation between bags within a multibag unit is symmetrical with respect to the length of the bags as shown. Optionally, the partial separation may be asymmetric even to the extent that partial separation begins at an edge of the multibag unit. Thus, in the example shown, bags 26 and 27 are held together by perforation segments 36 and 37 to unify the multibag unit. In Fig. 2B, there is shown a three bag multibag unit

45, having component bags 46, 47 and 48. Individual bags within unit 45 have been partially separated along their respective lines of perforation as indicated by segments AB as discussed in connection with Fig. 2A. Using the method and apparatus of the invention, multibag units of any number of bags may be made. As stated above, the bags are used preferably by longitudinally imbricating on carrier tape so that a series of such taped multibags may be fed to a conventional taped bag loader with the advantage that a multibag unit may be handled during loading, vacuumizing and sealing essentially as a single bag, thereby correspondingly multiplying output from the packaging operation. Optionally, the sealing operation may include trimming off excess material beyond the outermost seals of each unit. Following sealing of the loaded bags, the individual bags within a unit may be easily separated due to the pre-existing partial separation along the lines of perforation delimiting the bags within a multibag unit.

In Fig. 3, there is shown a side view of a preferred embodiment of the apparatus of the invention, hereinafter referred to as separator 50. Separator 50 has a first set of nip rollers 51 driven in counterrotating fashion. A feed chain of bags, as discussed in connection with Fig. 1, is indicated at 53 as being carried through the nip of roller set 51 having rollers 52A, B being in nipping contact with said feed chain 53. The chain of bags is propelled forward as shown at 54 from the nip of first roller set 51 into the nip of a second roller set 55 having bottom roller 57 driven so as to propel the chain of bags forward, as shown at 56. First roll set 51 and second roll set 55 are selectively spaced apart as shown at 61. Roll set 55 is driven at a speed faster than roll set 51 so that tension is exerted along the chain of bags across span 61 and therefore on the lines of perforation between the bags within the chain, respectively. Cooperating with bottom roll 57 in roll set 55 is separator mechanism 58.

In Fig. 4 a detailed perspective view is shown of roll set 55 and in particular separator mechanism 58. Downward pressure is exerted as indicated at arrow 59A on partial separator mechanism 59 having pivot arm 62 supporting partial separator rollers 63A, B, etc. Pressure at 59A is normally held essentially constant to effect partial separation along the lines of perforation within the series of bags, as previously shown in Fig. 2A by segment AB for example. Total separator mechanism 60 is periodically pressed against lower roll 57 from a relaxed position, as shown at arrow 60A. Thus, according to a conventional counting device (not shown) total separator mechanism 60 is actuated at periodic intervals to totally separate a multibag unit from the series of bags passing through separator 50, for example every third bag as shown in Fig. 2B, as caused by total separator rollers 64A, B being urged into nipping contact with lower roller 57 thereby extending the line of nip across the width of the feed series of bags to complete the nip.

Accordingly, in continuous operation, a supply of multibag units will rapidly build up from the exit of the nip of second roll set 55 as generally indicated at 56. This supply may then be imbricated on carrier tape by conventional methods. Preferably, spacing 61 between first roll set 51 and second roll set 55 of separator 50 is spaced less than or equal to about two times the bag width in the feed series of bags, so that only one line of perforation is present within spacing 61 at any given moment during operation.

Although the present invention has been described in conjunction with preferred embodiments, it is to be understood that modifications and variations may be utilized without departing from the principles and scope of the invention, as those skilled in the art will readily understand. Accordingly, such modifications and variations may be practiced within the scope of the following claims:

Claims

1. A method for making a supply of partially separated multibag units, comprising: passing a perforated chain of side-sealed bags through a first set of driven nip rollers; then passing said chain directly to a second set of nip rollers having a partial nip of selected width less than the width of said chain, while driving said second nip rollers at a speed greater than said first nip rollers sufficient to partially separate the bags at their respective lines of perforation; and cyclically completing the nip of said second nip rollers only at predetermined intervals corresponding to the passage through the nip of the second nip rollers of the number of bags desired in each multibag unit.

2. A method according to claim 1, further comprising spacing said second nip rollers upstream of said first set of nip rollers by a distance equal to or less than 2 bag widths.

3. A method according to claim 1 or 2, further comprising setting said partial nip spaced transversely from both edges of said bag chain.

4. A method according to claim 1 or 2, further comprising setting said partial nip to begin at an edge of said bag chain.

5. A method for making a supply of partially separated multibag units, comprising: passing a perforated chain of side-sealed bags through a first set of driven nip rollers; then passing said chain directly to a second set of nip rollers having a partial nip of selected width being symmetric widthwise of said bag chain and extending less than the width of said chain and spaced upstream from said first set of nip rollers by a distance equal to or less than about 2 bags widths while driving said second nip rollers at a speed greater than said first nip rollers sufficient to partially separate the bags at their respective lines of perforation

60 and cyclically completing the nip of said second nip rollers only at predetermined intervals corresponding to the passage through the nip of the second nip rollers of the number of bags desired in each multibag unit.

65 6. A method for making a supply of partially separated multibag units, such method being substantially as hereinbefore described with reference to the accompanying drawings.

70 7. An apparatus for making a supply of partially separated multibag units, comprising:

(a) means for passing a perforated chain of side-sealed bags through a first set of driven nip rollers;

75 (b) means for passing said chain directly to a second set of nip rollers, having a partial nip of selected width less than the width of said chain;

(c) means for driving said second nip rollers at a speed greater than said first nip rollers sufficient to partially separate the bags at their respective lines of perforation; and

80 (d) means for cyclically completing the nip of said second nip rollers only at predetermined intervals corresponding to the passage through the nip of said second nip rollers of the number of bags desired in each multibag unit.

85 8. Apparatus according to claim 7, further comprising means for adjusting the upstream spacing of said second set of nip rollers from said first set of nip rollers.

90 9. Apparatus according to claim 7 or 8, further comprising means in association with said nip-completing means for counting bags passing through the apparatus.

95 10. Apparatus according to any one of claims 7 to 9 further comprising means for adjusting the lateral extent of and location of said partial nip widthwise of said bag chain.

100 11. Apparatus according to any one of claims 7 to 10, wherein said second nip rollers comprise driven first roller means rotatable about a first axis and idling second roller means rotatable about a second axis parallel to said first axis for engagement with said first roller means over a limited axial region thereof: and wherein said nip-completing means includes idling third roller means rotatable about a third axis, and means for cyclically shifting said third axis towards and away from said first axis, for cyclically bringing said third roller means into engagement with said first roller means.

110 12. Apparatus according to claim 11 wherein said second roller means is supported for movement into and out of rolling engagement with said first roller means.

115 13. Apparatus for making a supply of partially separated multibag units, such apparatus being constructed and adapted to operate substantially as hereinbefore described with reference to the accompanying drawings.