



US00D965143S

(12) **United States Design Patent**
Doubet

(10) **Patent No.:** **US D965,143 S**

(45) **Date of Patent:** **** Sep. 27, 2022**

(54) **SYRINGE ADAPTER FOR MEDICATION**

Primary Examiner — David G Muller

(71) Applicant: **James T. Doubet**, Parker, CO (US)

(74) *Attorney, Agent, or Firm* — Marcia L. Doubet

(72) Inventor: **James T. Doubet**, Parker, CO (US)

(57) **CLAIM**

(**) Term: **15 Years**

I claim the ornamental design for a syringe adapter for medication, as shown and described.

(21) Appl. No.: **29/694,922**

DESCRIPTION

(22) Filed: **Jun. 14, 2019**

Related U.S. Application Data

(63) Continuation of application No. 16/010,155, filed on Jun. 15, 2018, now Pat. No. 11,337,894.

(51) **LOC (13) Cl.** **24-02**

(52) **U.S. Cl.**
USPC **D24/130**

(58) **Field of Classification Search**
USPC D24/112–114, 108, 133, 130, 127, 186;
606/181, 185; 604/264, 272, 187, 181,
604/184, 227

(Continued)

(56) **References Cited**

U.S. PATENT DOCUMENTS

2,752,919 A 7/1956 Gabriel
3,436,828 A 4/1969 Dragan
(Continued)

FOREIGN PATENT DOCUMENTS

EP 1923086 B1 4/2012
WO 2012/023955 A1 2/2012
WO 2017/091643 A1 6/2017

OTHER PUBLICATIONS

PCT Application PCT/US2019/062926, International Search Report dated Feb. 12, 2020 (2 pages).

(Continued)

FIG. 1 is a perspective view of a syringe adapter, showing a first embodiment of my new design having a radial extension;

FIG. 2 is a front view thereof, the back view, the top view, and the bottom view being identical thereto;

FIG. 3 is a left-side view thereof;

FIG. 4 is a right-side view thereof;

FIG. 5 is a perspective view of a syringe adapter, showing a second embodiment of my new design having a radial extension placed near the conical portion thereof;

FIG. 6 is a front view thereof, the back view, the top view, and the bottom view being identical thereto;

FIG. 7 is a left-side view thereof;

FIG. 8 is a right-side view thereof;

FIG. 9 is a perspective view of a syringe adapter, showing a third embodiment of my new design having a radial extension with a different diameter;

FIG. 10 is a front view thereof, the back view, the top view, and the bottom view being identical thereto;

FIG. 11 is a left-side view thereof;

FIG. 12 is a right-side view thereof;

FIG. 13 is a perspective view of a syringe adapter, showing a fourth embodiment of my new design having a shorter conical portion;

FIG. 14 is a front view thereof, the back view, the top view, and the bottom view being identical thereto;

FIG. 15 is a left-side view thereof; and,

FIG. 16 is a right-side view thereof.

Features shown in the drawings using broken lines form no part of the claimed design.

1 Claim, 6 Drawing Sheets

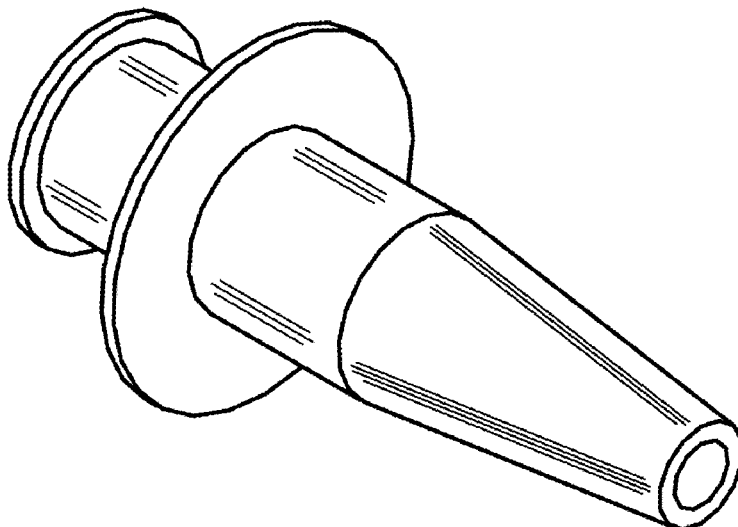

(58) **Field of Classification Search**
 CPC A61M 5/486; A61M 5/178; A61M 3/00;
 A61M 5/20; A61M 5/31; A61M 5/3146;
 A61M 5/3129; A61M 5/3148; A61M
 5/315

See application file for complete search history.

(56) **References Cited**

U.S. PATENT DOCUMENTS

3,958,570 A 5/1976 Vogelman et al.
 4,046,145 A 9/1977 Choksi et al.
 4,127,126 A * 11/1978 Schunk A61J 7/0053
 604/77
 4,294,250 A 10/1981 Dennehey
 4,316,462 A 2/1982 Baker
 4,338,925 A 7/1982 Miller
 4,472,141 A 9/1984 Dragan
 4,664,655 A 5/1987 Orentreich et al.
 4,758,158 A 7/1988 Pierce et al.
 4,758,234 A 7/1988 Orentreich et al.
 D297,262 S 8/1988 Sternweiler
 D297,365 S 8/1988 Barnett
 4,787,891 A * 11/1988 Levin A61M 5/3287
 604/136
 4,852,584 A 8/1989 Selby
 D310,722 S 9/1990 Broden
 D315,583 S 3/1991 Larson et al.
 D320,082 S 9/1991 Wyatt et al.
 5,047,021 A 9/1991 Utterberg
 5,195,985 A 3/1993 Hall
 D338,531 S 8/1993 Howell
 5,322,510 A 6/1994 Lindner et al.
 D358,882 S 5/1995 Metz et al.
 D368,304 S 3/1996 Morrison
 D380,037 S 6/1997 Granthan
 D381,425 S 7/1997 Cesarini et al.
 D382,639 S 8/1997 Musgrave et al.
 5,733,258 A 3/1998 Lane
 5,746,733 A 5/1998 Capaccio et al.
 D395,502 S 6/1998 Deily et al.
 D413,967 S 9/1999 Yuen
 5,971,968 A * 10/1999 Tu A61M 25/007
 604/103.01
 6,117,113 A 9/2000 Novacek et al.
 D435,652 S 12/2000 Nazarifar et al.
 6,511,472 B1 1/2003 Hayman et al.
 D473,305 S 4/2003 Halseth
 D473,646 S 4/2003 Baillargeon et al.
 D474,839 S 5/2003 Francavilla et al.
 D483,861 S * 12/2003 Law D24/112
 D484,593 S 12/2003 Baillargeon et al.
 D485,616 S 1/2004 Baillargeon et al.
 D489,819 S * 5/2004 Ford D24/112
 6,787,568 B1 9/2004 Mihalik
 6,790,867 B2 9/2004 Kohan et al.
 6,981,618 B2 1/2006 Reisinger
 D517,667 S 3/2006 Sener et al.
 D529,603 S * 10/2006 Knickerbocker D24/110
 7,347,458 B2 3/2008 Rome et al.
 7,472,932 B2 1/2009 Weber et al.
 7,682,343 B2 3/2010 Westbye
 7,699,609 B2 4/2010 Lawter et al.
 D617,429 S 6/2010 Govoni et al.
 7,811,251 B2 * 10/2010 Wenchell A61B 17/34
 604/107
 8,034,845 B2 10/2011 Freehauf et al.
 8,044,102 B2 10/2011 Kohan et al.
 D671,639 S 11/2012 Trifillio
 D672,052 S 12/2012 Bucher et al.
 D693,923 S 11/2013 Hernandez et al.
 8,631,795 B1 * 1/2014 McMurray A61M 16/04
 128/207.14
 D709,187 S * 7/2014 Li A61M 39/12
 D24/129
 D714,935 S 10/2014 Nishioka et al.

D716,916 S 11/2014 Snow
 8,961,490 B2 * 2/2015 Musani A61B 17/3496
 604/415
 D728,780 S * 5/2015 Pieroni D24/112
 D728,781 S * 5/2015 Pierson D24/112
 D731,065 S 6/2015 Winter
 D731,647 S 6/2015 Nishioka et al.
 D736,915 S 8/2015 Schultz
 D739,523 S 9/2015 Booth
 9,295,788 B2 3/2016 Green
 D757,233 S 5/2016 Vaz et al.
 D760,376 S 6/2016 Komeliussen et al.
 D773,659 S 12/2016 Cain
 D777,888 S 1/2017 Vaz et al.
 D799,032 S 10/2017 Becker
 D811,586 S 2/2018 Bureau
 D816,211 S 4/2018 Guala
 D818,580 S 5/2018 Khabiri et al.
 D823,460 S * 7/2018 Raghuvveer D24/114
 D825,737 S 8/2018 Yokoyama
 D831,202 S 10/2018 Ratner
 D841,499 S 2/2019 Drewes et al.
 D851,240 S 6/2019 Baid
 D851,759 S 6/2019 Jones et al.
 D865,954 S 11/2019 Mottola et al.
 D873,997 S 1/2020 Ljunglof et al.
 D884,888 S 5/2020 Doubet et al.
 D890,025 S 7/2020 Doubet et al.
 10,709,850 B2 7/2020 Doubet et al.
 2002/0099360 A1 7/2002 Bierman
 2002/0133124 A1 9/2002 Leinsing et al.
 2002/0173753 A1 11/2002 Caizza et al.
 2003/0236501 A1 12/2003 Donnan et al.
 2004/0068266 A1 4/2004 Delmotte
 2006/0270996 A1 11/2006 Fojtik
 2007/0060898 A1 3/2007 Shaughnessy et al.
 2007/0203451 A1 8/2007 Murakami et al.
 2008/0188816 A1 8/2008 Shimazaki et al.
 2008/0287884 A1 11/2008 Warden et al.
 2009/0182284 A1 7/2009 Morgan
 2009/0227894 A1 9/2009 Fojtik
 2010/0249650 A1 9/2010 Hikawa et al.
 2011/0028909 A1 2/2011 Lum et al.
 2013/0018354 A1 1/2013 Sund et al.
 2013/0178806 A1 7/2013 Felix-Faure et al.
 2014/0066840 A1 3/2014 Mantell
 2014/0261860 A1 9/2014 Heath et al.

OTHER PUBLICATIONS

PCT Application PCT/US2019/062926, Written Opinion of the International Searching Authority dated Feb. 12, 2020 (6 pages).
 In re James T. Doubet, et al., U.S. Appl. No. 29/710,061, filed Oct. 20, 2019, Office Action, dated Mar. 19, 2020, 8 pages.
 In re James T. Doubet, et al., U.S. Appl. No. 29/715,259, filed Nov. 29, 2019, Office Action, dated Mar. 17, 2020, 8 pages.
 In re James T. Doubet, U.S. Appl. No. 16/393,696, filed Apr. 24, 2019, Office Action, dated Jun. 27, 2019, 17 pages.
 "List of Patents or Patent Applications to be Treated as Related". Aug. 4, 2019. 2 pages.
 PCT Application PCT/US2019/056282, International Search Report dated Jan. 7, 2020 (2 pages).
 PCT Application PCT/US2019/056282, Written Opinion of the International Searching Authority dated Jan. 7, 2020 (5 pages).
 In re James T. Doubet, U.S. Appl. No. 16/393,696, filed Apr. 24, 2019, Office Action, dated Jan. 10, 2020, 16 pages.
 In re James T. Doubet, et al., U.S. Appl. No. 16/563,896, filed Sep. 8, 2019, Office Action, dated Jan. 10, 2020, 11 pages.
 In re James T. Doubet, et al., U.S. Appl. No. 16/698,471, filed Nov. 27, 2019, Office Action, dated Jan. 10, 2020, 14 pages.
 In re James T. Doubet, et al., U.S. Appl. No. 29/710,061, filed Oct. 20, 2019, Office Action, dated Feb. 21, 2020, 8 pages.
 "(Revised) List of Patents or Patent Applications to be Treated as Related". Mar. 4, 2020. 2 pages.
 "(Revised) List of Patents or Patent Applications to be Treated as Related". Sep. 27, 2019. 2 pages.

(56)

References Cited

OTHER PUBLICATIONS

Colomer, S., et al., "Syringeability and Viscosity Comparative of Different Florfenicol Formulations", publication date unknown, printed from http://marketing.hipra.com/SELECTNEWS/trials/Syringeability_viscosity_comparative_of_FLORFENICOL_formulations.pdf on May 14, 2018. 1 page.

"(Revised) List of Patents and/or Patent Applications to be Treated as Related". Feb. 11, 2021. 2 pages.

PCT Application PCT/US2019/036774, International Search Report dated Sep. 16, 2019 (2 pages).

PCT Application PCT/US2019/036774, Written Opinion of the International Searching Authority dated Sep. 16, 2019 (5 pages).

* cited by examiner

FIG. 1

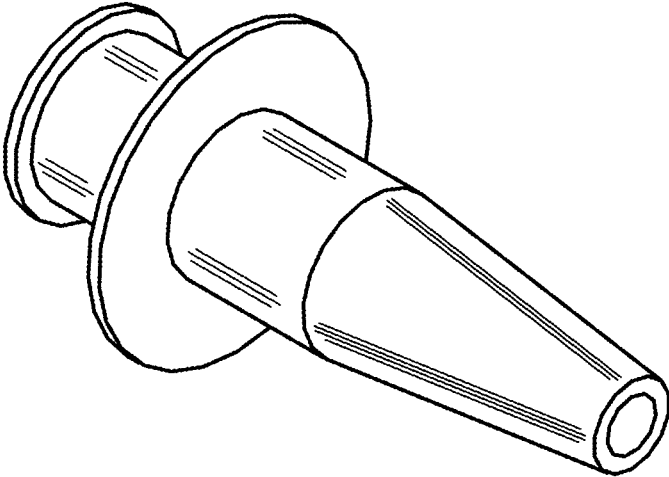

FIG. 2

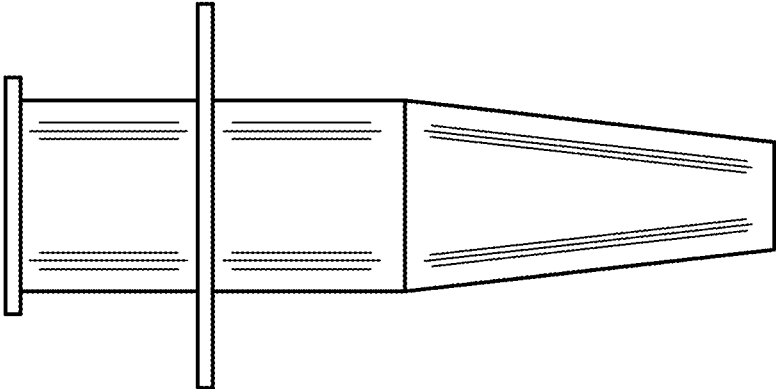

FIG. 3

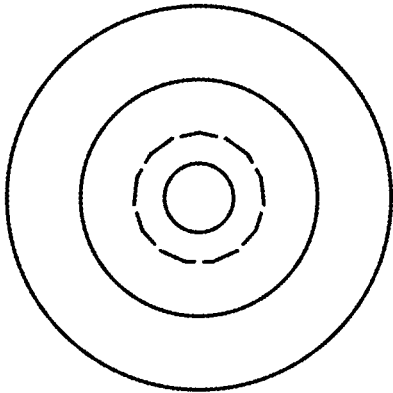

FIG. 4

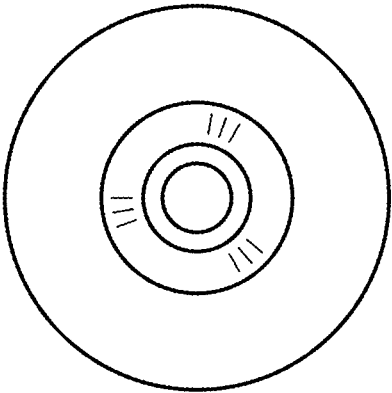

FIG. 5

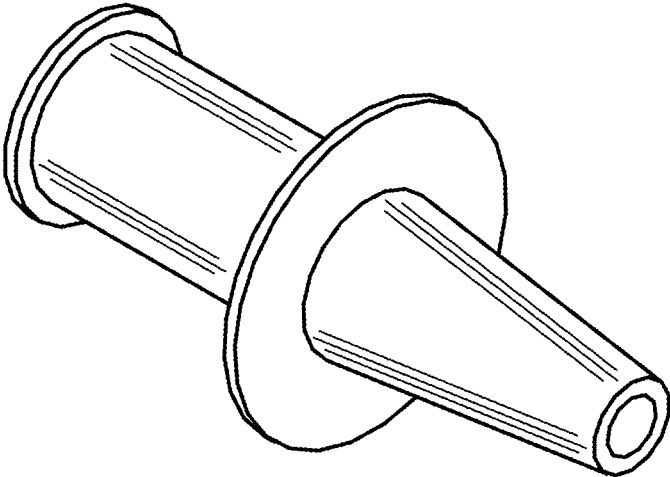

FIG. 6

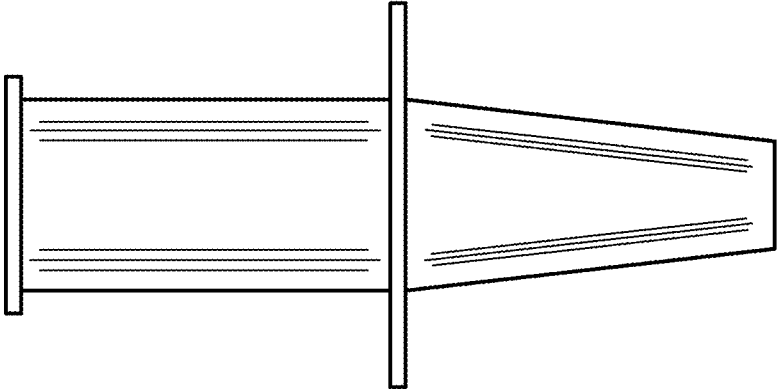

FIG. 7

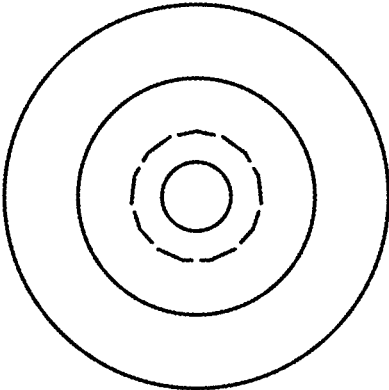

FIG. 8

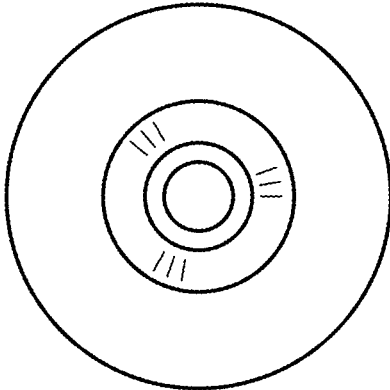

FIG. 9

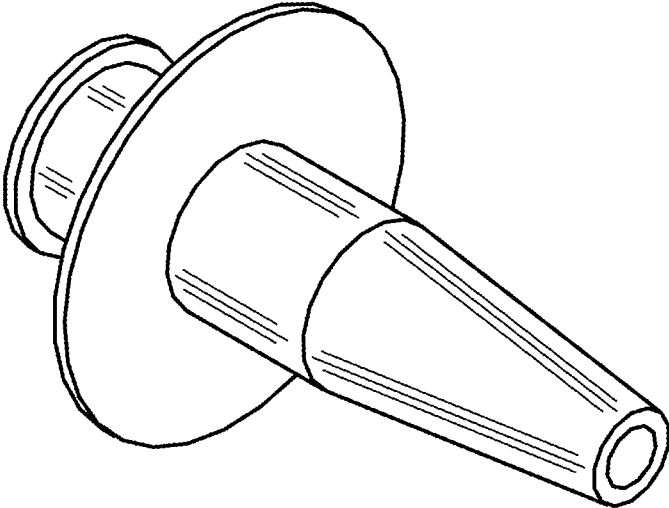

FIG. 10

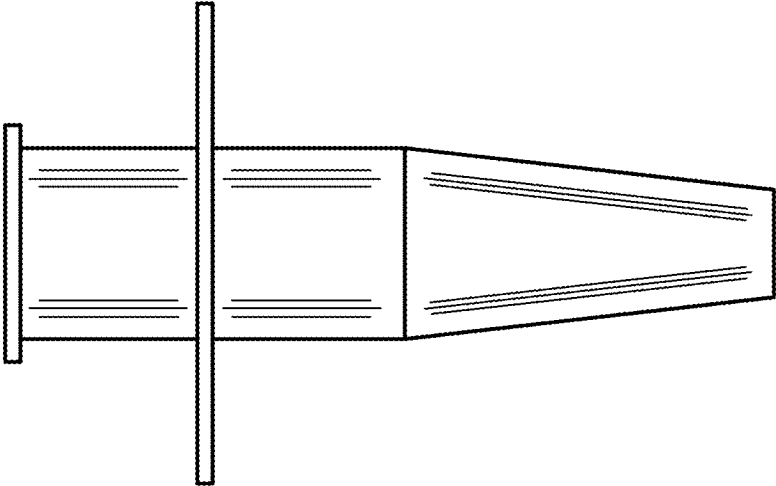

FIG. 11

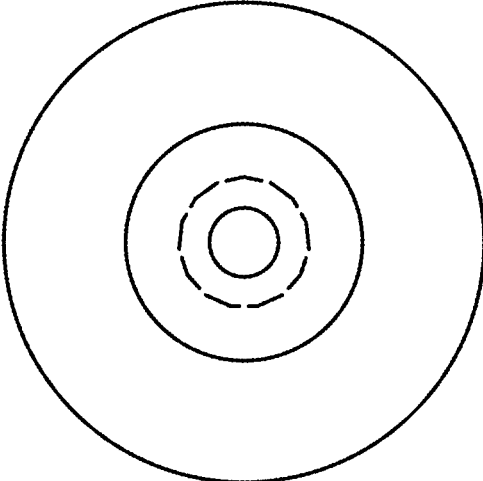

FIG. 12

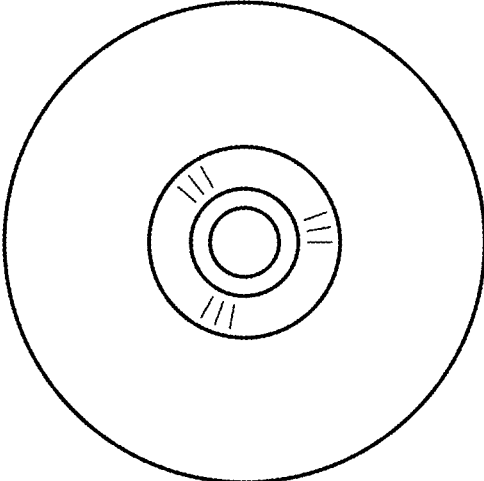

FIG. 13

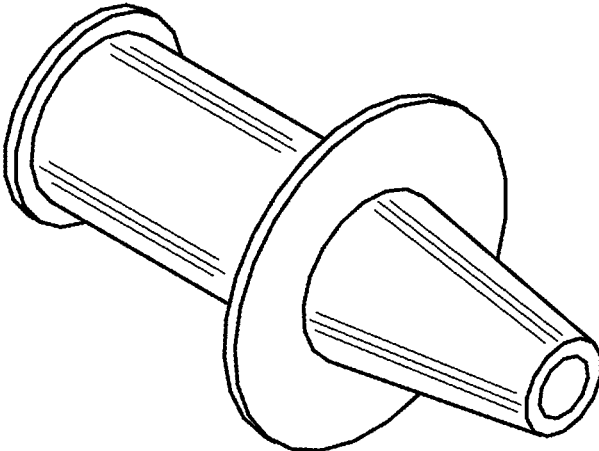

FIG. 14

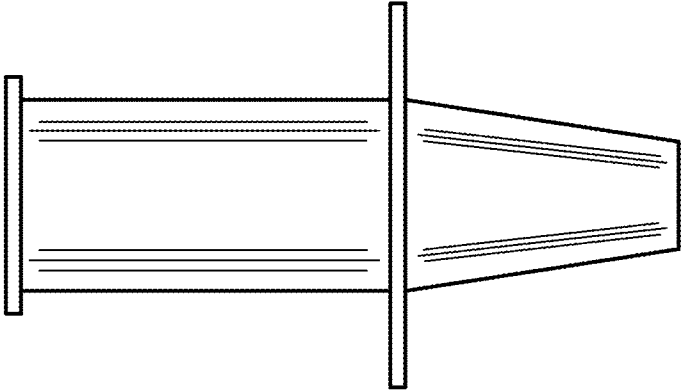

FIG. 15

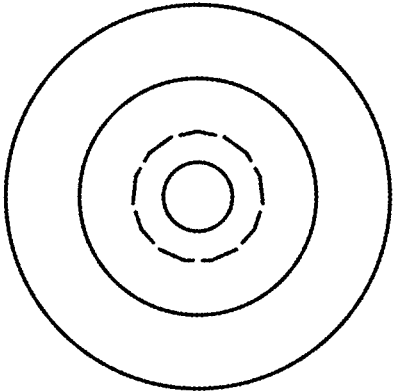

FIG. 16

