



(22) 1992/07/23

(43) 1993/01/24

(62) 2,092,199

(22) 1992/07/23

- (72) OSBORN, Thomas Ward III, US
(72) LAVASH, Bruce William, US
(72) SUGAHARA, Kazuko, JP
(72) CHAPPELL, Charles, US
(72) MAYER, Katherine Louise, US
(72) HINES, Letha Margie, US
(72) CHARRIER, Jacqueline Watson, US
(71) PROCTER & GAMBLE COMPANY (THE), US
(51) Int.Cl.⁶ A61F 13/15
(30) 1991/07/23 (734,392) US
(30) 1991/07/23 (734,405) US
(30) 1991/07/23 (734,404) US
(30) 1992/04/28 (874,872) US
(30) 1992/05/14 (882,738) US
(54) **ARTICLES ABSORBANTS EXTENSIBLES**
(54) **STRETCHABLE ABSORBENT ARTICLES**

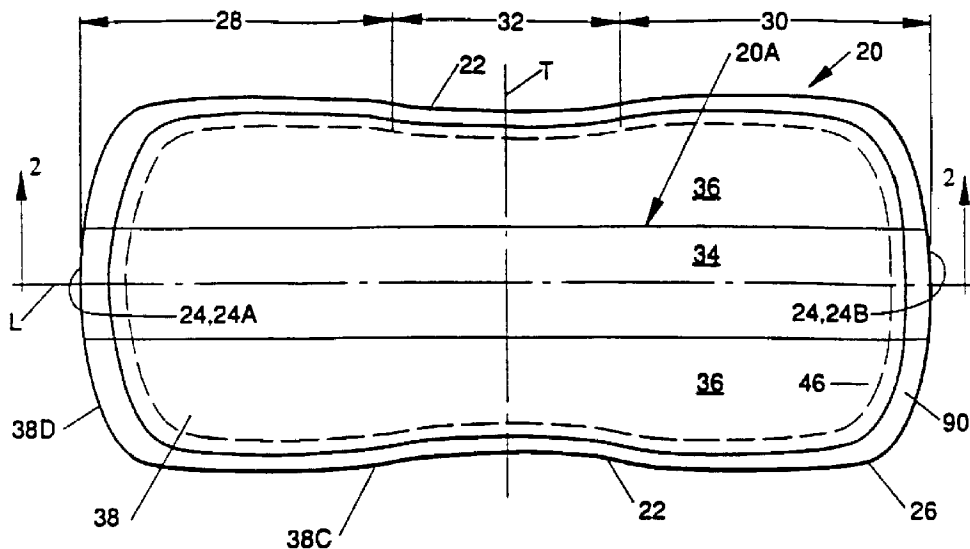

(57) Cette invention concerne des articles absorbants tels que des serviettes hygiéniques, plus précisément, des serviettes hygiéniques minces et extensibles, principalement dans le sens de la longueur.

(57) The present invention relates to absorbent articles such as sanitary napkins worn by women. More particularly, the present invention relates to absorbent articles, such as thin sanitary napkins, that are stretchable, especially in the longitudinal direction.

ABSTRACT

The present invention relates to absorbent articles such as sanitary napkins worn by women. More particularly, the present invention relates to absorbent articles, such as thin sanitary napkins, that are stretchable, especially in the longitudinal direction.

STRETCHABLE ABSORBENT ARTICLES

FIELD OF THE INVENTION

The present invention relates to absorbent articles such as sanitary napkins, panty liners, and incontinent pads. More particularly, the present invention relates to sanitary napkins that are extensible or, more preferably stretchable, especially in the longitudinal direction.

BACKGROUND OF THE INVENTION

Absorbent articles such as sanitary napkins, pantliners, and incontinent pads are designed to absorb and retain liquid and other discharges from the human body and to prevent body and clothing soiling. Sanitary napkins are a type of absorbent article worn by women that is normally positioned between the wearer's legs, adjacent to the perineal area of the body.

Typically, most of the disposable absorbent articles of the types mentioned above are made of materials that will not stretch. That is, the materials (and the article itself) will not stretch under the forces that the absorbent article is normally subjected to when worn.

The inability of the absorbent articles to stretch causes such articles to have a number of serious drawbacks. One of the most serious is that they are not as comfortable for the wearer as they could be. The wearer should ideally be able to notice a difference between an absorbent article that stretches to conform to the wearer's body and with the wearer's movements and an absorbent article that fails to stretch. Conventional sanitary napkins will also fail to move with the wearer's undergarments, causing the sanitary napkins to shift. Providing the sanitary napkin with stretch properties will permit the napkin to better conform to the wearer's undergarment and stay in place.

Several patent publications disclose absorbent articles having various components that are capable of stretching. Such efforts are described in U.S. Patent 2,701,567 issued to Smith, U.S. Patent 3,570,493 issued to Olsson, U.S. Patent 3,653,382 issued to Easley, et al., U.S. Patent 3,717,150, issued to Schwartz, U.S. Patent 4,013,816 issued to Sabee, et al., U.S. Patent 4,041,949 issued to Kozak, U.S. Patent 4,166,464 issued to Korpman, U.S. Patent 4,533,357 issued to Hall, U.S. Patent 4,573,991 issued to Pieniak, et al., U.S. Patent 4,578,070 issued to Holtman, U.S. Patent 4,596,570 issued to Jackson, et al., U.S. Patent 4,655,760 issued to Morman, et al. U.S. Patent 4,731,066 issued to Korpman, U.S. Patent 4,847,134 issued to Fahrenkrug, et al., U.S. Patent 4,891,258 issued to Fahrenkrug, et al., U.S. Patent 4,965,122 issued to Morman, U.S. Patent 4,992,324 issued to Dube, U.S. Patent 5,011,480 issued to Gossens, et al., and European Patent Application 0 450 541 A2 published in the name of Morris, et al.

The publications listed above may disclose providing absorbent articles with one or more stretchable components. The present invention, however, is directed to absorbent articles, such as sanitary napkins, that in a number of embodiments are comprised entirely of components capable of stretching to accommodate the movements of the wearer and the wearer's

undergarments. The present application also is directed to a vast number of embodiments for utilizing stretch properties to improve the fit of the absorbent article.

It is an object of an aspect of this invention to provide an absorbent article, particularly a relatively thin absorbent article, such as a sanitary napkin, that is capable of extending, or more preferably, stretching.

It is an object of an aspect of this invention to provide such an absorbent article that is capable of extending (and preferably stretching) in the longitudinal direction when the article is worn for improved comfort and fit.

These and other objects of the present invention will be more readily apparent when considered in reference to the following description and when taken in conjunction with the accompanying drawings.

SUMMARY OF THE INVENTION

The present invention provides an absorbent article, such as a sanitary napkin. The sanitary napkin of the present invention is capable of extending.

The sanitary napkin, however, may be extensible in length (i.e., in the longitudinal direction) and/or width (i.e., in the transverse direction), and/or in other directions. The sanitary napkin is preferably also elastically extensible.

The sanitary napkin of the present invention, in one embodiment comprises an extensible liquid pervious topsheet, an extensible liquid impervious backsheet, and an extensible absorbent core. The absorbent core is positioned between the topsheet and the backsheet. The topsheet and backsheet are joined together around the periphery of the sanitary napkin. The sanitary napkin also comprises a fastener for attaching the

- 4a -

Other aspects of this invention are as follows:

An extensible sanitary napkin for wearing in a crotch region of a pair of panties, said sanitary napkin having a body surface, a garment surface, a longitudinal dimension, a transverse dimension that is less than said longitudinal dimension, a longitudinal centerline extending in said longitudinal dimension, a transverse centerline extending in said transverse dimension, an initial dimension measured along each of said centerlines, and an extended dimension measured along at least one of said centerlines, said sanitary napkin comprising:

an extensible liquid pervious topsheet;

an extensible liquid impervious backsheet joined to said topsheet;

an extensible absorbent core positioned between said topsheet and said backsheet;
and

an extensible adhesive fastener on said garment surface for removably attaching said sanitary napkin to the crotch region of the wearer's panties, wherein

when said sanitary napkin is subjected to outwardly-oriented stretching forces of between about 50 grams and about 1,500 grams along one of said centerlines, said sanitary napkin extends to an extended dimension along said centerline that is greater than or equal to 105% and less than 150% of its initial dimension measured along the same centerline.

An extensible absorbent article for attaching to and wearing in an undergarment, said absorbent article having a longitudinal centerline, two transverse end edges, a liquid pervious side, a liquid impervious side, an absorbent component positioned between said liquid pervious side and said liquid impervious side, wherein a portion of said absorbent article contains said absorbent component and a fastener for removably attaching said absorbent article to an undergarment, said fastener having two transverse ends, wherein said absorbent article has an initial dimension measured when said absorbent article is subjected to a force of 50 grams, and the portion of said absorbent article containing said absorbent component will extend to a dimension that is at least about 120% of its initial dimension and less than about 150% of its initial dimension before the absorbent article shears from a cotton fabric.

- 4b -

An absorbent article having an extensible attachment device for attachment to a crotch region of an undergarment, said sanitary napkin comprising:

a liquid pervious topsheet;

a liquid impervious backsheet joined to said topsheet;

an absorbent core positioned between said topsheet and said backsheet;

an extensible attachment device comprising at least one extensible component at least a portion of which is attached to at least one of said topsheet, backsheet, or absorbent core; and

a fastener on said extensible attachment device for fastening said sanitary napkin to said undergarment.

An absorbent article having regions of differential extensibility for wearing in a crotch region of an undergarment, said absorbent article comprising a liquid pervious side, a liquid impervious side, and an absorbent core positioned between said liquid pervious side and said liquid impervious side, said regions of differential extensibility comprising:

a region of first extensibility having a first initial dimension and a first extended dimension, said region of first extensibility being capable of extension between about 115% to about 150% of its first initial dimension when subjected to a force of between about 50 grams and about 1,500 grams;

a region of second extensibility having a second initial dimension and a second extended dimension, said region of second extensibility being capable of extension between about 115% to about 150% of its second initial dimension when subjected to a force of between about 50 grams and about 1,500 grams;

wherein the force required to extend said region of first extensibility a given distance is greater than the force required to extend said region of second extensibility the same distance in the same direction.

- 4c -

An extensible sanitary napkin for wearing in a crotch region of a pair of panties, said sanitary napkin having a body surface, a garment surface, a longitudinal dimension, a transverse dimension that is less than said longitudinal dimension, a longitudinal centerline extending in said longitudinal dimension, a transverse centerline extending in said transverse dimension, an initial dimension measured along each of said centerlines, and an extended dimension measured along at least one of said centerlines, said sanitary napkin comprising:

an extensible liquid pervious topsheet;

an extensible liquid impervious backsheet joined to said topsheet;

an extensible absorbent core positioned between said topsheet and said backsheet; and

an extensible adhesive fastener on said garment surface for attaching said sanitary napkin to the crotch region of the pair of panties, wherein

when said sanitary napkin is subjected to outwardly-oriented stretching forces of between about 50 grams and about 800 grams along one of said centerlines, said sanitary napkin extends to an extended dimension along said centerline that is greater than or equal to 110% and less than 150% of its initial dimension measured along the same centerline.

An extensible sanitary napkin for wearing in a crotch region of a pair of panties, said sanitary napkin having a body surface, a garment surface, a longitudinal dimension, and a

- 4d -

transverse dimension that is less than said longitudinal dimension, a longitudinal centerline extending in said longitudinal dimension, a transverse centerline extending in said transverse dimension, an initial dimension measured along each of said centerlines, and an extended dimension measured along at least one of said centerlines, said sanitary napkin comprising:

an extensible liquid pervious topsheet;

an extensible liquid impervious backsheet joined to said topsheet;

an extensible absorbent core positioned between said topsheet and said backsheet; and

an inextensible adhesive fastener comprising fastener portions intermittently positioned on said garment surface for attaching said sanitary napkin to the crotch region of the pair of panties, said fastener portions defining extensible portions of said sanitary napkin therebetween, and permitting said extensible portions of said sanitary napkin located between said fastener portions to extend, wherein

when said sanitary napkin is subjected to outwardly-oriented stretching forces of between about 50 grams and about 1,500 grams along one of said centerlines, said sanitary napkin extends to an extended dimension along said centerline that is greater than or equal to 105% and less than 150% of its initial dimension measured along the same centerline.

An extensible sanitary napkin for wearing in a crotch region of a pair of panties, said sanitary napkin having a body surface, a garment surface, a longitudinal dimension, and a

- 4e -

transverse dimension that is less than said longitudinal dimension, a longitudinal centerline extending in said longitudinal dimension, a transverse centerline extending in said transverse dimension, an initial dimension measured along each of said centerlines, and an extended dimension measured along at least one of said centerlines, said sanitary napkin comprising:

an extensible liquid pervious topsheet;

an extensible liquid impervious backsheet joined to said topsheet;

an extensible absorbent core positioned between said topsheet and said backsheet; and

an extensible mechanical fastener on said garment surface for attaching said sanitary napkin to the crotch region of the pair of panties, said extensible mechanical fastener comprising a patch of extensible material defining a surface and having a plurality of hooks projecting from the surface of said extensible material, wherein

when said sanitary napkin is subjected to outwardly-oriented stretching forces of between about 50 grams and about 1,500 grams along one of said centerlines, said sanitary napkin extends to an extended dimension along said centerline that is greater than or equal to 105% and less than 150% of its initial dimension measured along the same centerline.

An extensible sanitary napkin for wearing in a crotch region of a pair of panties, said sanitary napkin having a body surface, a garment surface, a longitudinal dimension, and a transverse dimension, and comprising:

- 4f -

an extensible liquid pervious topsheet;

an extensible liquid impervious backsheet joined to said topsheet;

an extensible absorbent core positioned between said topsheet and said backsheet; and

a fastener on said garment surface for attaching said sanitary napkin to the crotch region of the pair of panties, wherein

said topsheet, backsheet, absorbent core, and fastener are extensible under the forces associated with wearing the sanitary napkin in the panties.

An extensible absorbent pad for wearing in a crotch region of a pair of panties, said absorbent pad having a body surface, a garment surface, a longitudinal dimension, and a transverse dimension, and comprising:

an extensible absorbent element;

an extensible liquid impervious backsheet joined to said absorbent element;

a fastener on said garment surface for attaching said absorbent pad to the crotch region of the pair of panties, wherein

said absorbent core, backsheet, and fastener are extensible under the forces associated with wearing the absorbent pad in the panties.

- 4g -

An extensible sanitary napkin for wearing in a crotch region of a pair of panties, said sanitary napkin having a body surface, a garment surface, a longitudinal dimension, and a transverse dimension, and comprising:

an extensible liquid pervious topsheet;

an extensible liquid impervious backsheet joined to said topsheet;

an absorbent core positioned between said topsheet and said backsheet; and

a fastener on said garment surface for attaching said sanitary napkin to the crotch region of the pair of panties, wherein

said topsheet, backsheet, and fastener are extensible under the forces associated with wearing the sanitary napkin in the panties.

An extensible sanitary napkin for wearing in a crotch region of a pair of panties, said sanitary napkin having a body surface, a garment surface, a longitudinal dimension, and a transverse dimension, and comprising:

an extensible liquid pervious topsheet;

an extensible liquid impervious backsheet joined to said topsheet by bonds;

an extensible absorbent core positioned between said topsheet and said backsheet; and

- 4h -

a fastener on said garment surface for attaching said sanitary napkin to the crotch region of the pair of panties, wherein

said sanitary napkin is extensible up to less than about 50% of its initial length without ripping or tearing said topsheet, backsheet, and absorbent core and breaking the bonds between said topsheet and said backsheet.

An extensible sanitary napkin for wearing in a crotch region of a pair of panties, said sanitary napkin having a body surface, a garment surface, a longitudinal dimension, and a transverse dimension, and comprising:

an extensible liquid pervious topsheet;

an extensible liquid impervious backsheet joined to said topsheet;

an extensible absorbent core positioned between said topsheet and said backsheet; and

an extensible fastener on said garment surface for attaching said sanitary napkin to the crotch region of the pair of panties, wherein

when said sanitary napkin is attached to the crotch region of the pair of panties, said sanitary napkin will have an initial dimension before said panties are pulled into place against a wearer's body, and said sanitary napkin will extend to an extended dimension that is greater than said initial dimension when said panties and said sanitary napkin are pulled in place against the wearer's body.

- 4i -

A sanitary napkin that is extensible in response to stretching forces, said sanitary napkin having a specific extended dimension at increasing increments of stretching force, wherein said extended dimension of said sanitary napkin and said stretching force can be plotted on a graph with the extended dimension of said sanitary napkin on the x axis and the stretching force on the y axis so that a series of points are formed on the graph for each force, and said series of points form a curve, and said sanitary napkin comprises:

a structure that provides said sanitary napkin with a force wall wherein said sanitary napkin has an extended dimension at said force wall, and said force wall prevents said sanitary napkin from extending beyond said extended dimension at said force wall without the application of an substantial additional force, wherein said force wall is activated at the force where said graph has an inflection point.

An extensible sanitary napkin for wearing in a crotch region of a pair of panties, said sanitary napkin having a body surface, a garment surface, a longitudinal dimension, a transverse dimension that is less than said longitudinal dimension, a longitudinal centerline extending in said longitudinal dimension, a transverse centerline extending in said transverse dimension, an initial dimension measured along each of said centerlines, and an extended dimension measured in a direction parallel to at least one of said centerlines, said sanitary napkin comprising:

an extensible liquid pervious topsheet;

an extensible liquid impervious backsheet joined to said topsheet;

- 4j -

an extensible absorbent core positioned between said topsheet and said backsheet; and

an extensible fastener on said garment surface for attaching said sanitary napkin to the crotch region of the pair of panties, wherein

when said sanitary napkin is subjected to outwardly-oriented stretching forces of between about 50 grams and about 1,500 grams parallel to one of said centerlines, said sanitary napkin extends to an extended dimension along said centerline that is greater than or equal to 105% and less than 150% of its initial dimension measured parallel to the same centerline.

A sanitary napkin for wearing in a crotch region of a pair of panties, said sanitary napkin having a body surface, a garment surface, a longitudinal dimension, a transverse dimension that is less than said longitudinal dimension, a pair of longitudinal side edges, a pair of end edges, a longitudinal centerline extending in said longitudinal dimension, a transverse centerline extending in said transverse dimension, a first end region extending from one end edge toward the transverse centerline, a second end region extending from the other end edge toward said transverse centerline, a central region disposed between said first and second end regions, an initial dimension measured along each of said centerlines, and an extended dimension measured along at least one of said centerlines, said sanitary napkin comprising:

an extensible liquid pervious topsheet;

an extensible liquid impervious backsheet joined to said topsheet;

- 4k -

an absorbent element positioned between said topsheet and said backsheet, said absorbent element having a first end region, a second end region, and a central region, wherein said first and said second end regions of said absorbent element are more extensible than the central region of said absorbent element;

an extensible absorbent piece positioned adjacent said absorbent element in said central region of said sanitary napkin, said extensible absorbent piece being more extensible than the central region of said absorbent element; and

an extensible adhesive fastener on said garment surface for attaching said sanitary napkin to the crotch region of the pair of panties.

BRIEF DESCRIPTION OF THE DRAWINGS

While the specification concludes with claims particularly pointing out and distinctly claiming the subject matter which is regarded as forming the present invention, it is believed that the invention will be better understood from the following description which is taken in conjunction with the accompanying drawings (which are not necessarily to scale), in which like designations are used to designate substantially identical elements, and in which:

FIG. 1 is a top plan view of a stretchable sanitary napkin according to the present invention in unstretched condition.

FIG. 2 is a schematic sectional view taken along line 2-2 of the sanitary napkin shown in FIG. 1 in a disassembled condition.

FIG. 3 is a bottom plan view of the sanitary napkin shown in FIG. 1 without the optional adhesive cover strip.

FIG. 4 is a top plan view taken which shows the sanitary napkin in FIG. 1 after stretching.

FIG. 5 is a top plan view of a stretchable sanitary napkin which has optional side flaps and a topsheet fusion bonded to an underlying component.

FIG. 6 is a simplified transverse cross-sectional view taken along line 6-6 of Figure 5.

FIG. 7 is a simplified transverse cross-sectional view similar to that of Figure 6, showing an alternate arrangement of the components of the sanitary napkin.

6

FIG. 8 is a graph which shows the preferred relationship between the magnitude of stretching forces applied to the sanitary napkin and the amount the sanitary napkin stretches in response to such forces.

FIG. 8A is a plan view showing the extension of various portions of a sanitary napkin in a wearer's panties.

FIG. 9 is a graph which illustrates the forces required to stretch a sanitary napkin having a "force wall".

FIGS. 10 and 11 are schematic side views of structures used to create force walls.

FIG. 12 is an edge view of an alternative topsheet that comprises a nonwoven material and an apertured film.

FIG. 13 is a simplified schematic view of a topsheet material that comprises an apertured film with entangled nonwoven fibers.

FIG. 14 is a top plan view of a sanitary napkin having a topsheet comprised of a nonwoven web with fibers generally oriented in the transverse direction (only a portion of which are shown).

FIG. 15 is a photograph showing a cross-sectional view of an embodiment on which an underlying fibrous layer has been stretched and bonded to an apertured film.

FIG. 16 is a top plan view of a sanitary napkin having a topsheet comprising an elastic scrim with fibers entangled with the scrim. (The scrim is shown on a greatly enlarged scale, and only a portion of the scrim is shown.)

FIG. 17 shows a conventional process that could be used to cut a web of stretchable material into individual topsheets, and a

process for creating a multi-directional stretch topsheet by cutting the web of stretchable material fed into the process at an angle (or on a "bias" to the machine direction).

FIG. 17A is a plan view of a film topsheet for a sanitary napkin that has apertures that may provide the topsheet with extensibility.

FIG. 17B is a schematic plan view of a reversibly necked topsheet material.

FIG. 18 is an exploded perspective view showing the assembly of a stretchable sanitary napkin provided with a slit absorbent core.

FIG. 18A is a plan view showing a preferred glue pattern applied to the underside of the topsheet of the sanitary napkin shown in Figure 18.

FIG. 19 is a plan view of an absorbent core slit in the middle and not at the ends.

FIG. 20 is a plan view of an absorbent core provided with diamond-shaped apertures.

FIGS. 21-23 are top plan and simplified cross-sectional views along lines 22-22 and 23-23, respectively, of a thick sanitary napkin having a blended core and a profiled shape.

FIGS. 23A and 23B are a schematic top plan and cross-sectional views, respectively, of a sanitary napkin formed with some extensible components and some inextensible components.

FIG. 23C is a schematic cross-sectional view of another sanitary napkin formed with some extensible components and some inextensible components.

8

FIGS. 24-27 are bottom plan views of sanitary napkins which show examples of some panty fastener configurations.

FIG. 28 is a plan view of a backsheet provided with regions of differential extensibility.

FIGS. 29-31 are plan views of absorbent cores provided with regions of differential extensibility.

FIGS. 32-43 show alternative sanitary napkins that are provided with stretchable attachment devices for attachment to the wearer's panties.

FIGS. 44-49 show alternative sanitary napkins that have mechanical attachment devices for attachment to the wearer's panties.

FIGS. 50-54 show alternative embodiments of the sanitary napkin of the present invention which have pull-out tabs.

FIGS. 55-56 and 58-61 show alternative embodiments of the sanitary napkin of the present invention (or portions thereof) which may be extended by the forces exerted on the sanitary napkin in use.

FIGS. 62-66 show an alternative embodiment of the sanitary napkin of the present invention that have a cinch.

FIGS. 67-69 show an alternative embodiment of the sanitary napkin of the present invention which has a center region that deflects in response to stretching forces.

FIGS. 70-73 are schematic drawings that show the forces the cause the central region of the sanitary napkin in FIGS. 67-69 to deflect.

FIGS. 74 and 75 are schematic representations which show the benefits of providing the sanitary napkin shown in FIGS. 67-69 where the ability of the core to stretch is limited to the central region of the core.

FIGS. 76 and 77 are plan, and cross-sectional views, respectively, of a sanitary napkin having a mechanism for causing the central region of the sanitary napkin to deflect when the wearer sits or squats.

FIGS. 78 and 79 are schematic plane views showing the force transferring element of the sanitary napkin shown in FIGS. 76 and 77.

FIGS. 80 and 81 show a sanitary napkin embodiment (similar to that shown in FIGS. 76 and 77) which is provided with a spacing structure.

FIGS. 82-83 show an alternative embodiment of the sanitary napkin of the present invention which has a pop-up center.

FIGS. 84-85 show alternative embodiments of the sanitary napkin of the present invention which have regions of differential stretchability.

FIGS. 86 and 87 are schematic cross-sectional representations of the configurations. the sanitary napkin in FIGS 84-85 may take when stretched.

DETAILED DESCRIPTION OF THE INVENTION

1. Overall Characteristics of the Absorbent Article

The overall characteristics of the absorbent article of the present invention will be discussed first.

10

FIGS. 1-3 show a preferred embodiment of a disposable absorbent article of the present invention. The present invention relates to absorbent articles, such as sanitary napkins. More particularly, the present invention relates to thin sanitary napkins that are stretchable, especially in the longitudinal direction.

The term "absorbent article", as used herein, refers to articles which absorb and contain body exudates. More specifically, the term refers to articles which are placed against or in proximity to the body of the wearer to absorb and contain the various exudates discharged from the body. The term "absorbent article" is intended to include sanitary napkins, pantliners, and incontinent pads (and other articles worn in the crotch region of a garment).

The term "disposable" refers to articles which are intended to be discarded after a single use and preferably recycled, composted, or otherwise disposed of in an environmentally compatible manner. (That is, they are not intended to be laundered or otherwise restored or reused as an absorbent article.) In the preferred embodiment illustrated, the absorbent article is a sanitary napkin designated 20.

The term "sanitary napkin", as used herein, refers to an article which is worn by females adjacent to the pudendal region that is intended to absorb and contain the various exudates which are discharged from the body (e.g., blood, menses, and urine). The present invention, however, is not limited to the particular types or configurations of absorbent articles shown in the drawings.

The sanitary napkin 20 has two surfaces, a liquid pervious body-contacting surface or "body surface" 20A and a liquid impervious garment surface 20B. The sanitary napkin 20 is shown in FIG. 1 as viewed from its body surface 20A. The body surface 20A is intended to be worn adjacent to the body of the wearer.

11

The garment surface 20B of the sanitary napkin 20 (shown in FIG. 2) is on the opposite side and is intended to be placed adjacent to the wearer's undergarments when the sanitary napkin 20 is worn.

The sanitary napkin 20 has two centerlines, a longitudinal centerline L and a transverse centerline T. The term "longitudinal", as used herein, refers to a line, axis or direction in the plane of the sanitary napkin 20 that is generally aligned with (e.g., approximately parallel to) a vertical plane which bisects a standing wearer into left and right body halves when the sanitary napkin 20 is worn. The terms "transverse" or "lateral" used herein, are interchangeable, and refer to a line, axis or direction which lies within the plane of the sanitary napkin 20 that is generally perpendicular to the longitudinal direction.

FIG. 1 shows that the sanitary napkin 20 also has two spaced apart longitudinal edges 22 and two spaced apart transverse or end edges (or "ends") 24, which together form the periphery 26 of the sanitary napkin 20. When the sanitary napkin 20 is worn, one of the end edges 24 will be oriented toward the front of the wearer, and one of the end edges 24 will be oriented toward the rear of the wearer. The end edge 24 oriented toward the front of the wearer is designated 24A, and the end edge oriented toward the rear of the wearer is designated 24B.

The sanitary napkin has two end regions, which are designated first end region 28 and second end region 30. A central region 32 is disposed between the end regions 28 and 30. The end regions 28 and 30 extend outwardly from the edges of the central region 32 about 1/8 to about 1/3 of the length of the sanitary napkin. A detailed description of the central region 32 and the two end regions 28 and 30 is contained in U.S. Patent 4,690,680 issued to Higgins on September 1, 1987.

12

The sanitary napkin also has a longitudinally-oriented (or longitudinal) central region 34 disposed along the length of at least a portion of the longitudinal centerline L, and longitudinal side regions 36 laterally outboard of the longitudinal central region 34.

The sanitary napkin 20 can be of any thickness, including relatively thick, relatively thin, or even very thin. The embodiment of the sanitary napkin 20 shown in Figures 1-3 of the drawings is intended to be an example of a relatively thin sanitary napkin, preferably an "ultra-thin" sanitary napkin. It should be understood, however, when viewing these figures the number of layers of material shown cause the sanitary napkin 20 to appear much thicker than it actually is. An "ultra-thin" sanitary napkin 20 preferably has a caliper of less than about 3 millimeters. The thin sanitary napkin 20 shown should also be preferably relatively flexible, so that it is comfortable for the wearer.

FIG. 2 shows the individual components of the sanitary napkin. The sanitary napkin 20 of the present invention generally comprises at least four primary components. These include a liquid pervious topsheet 38, a liquid impervious backsheet (or "barrier means") 40, an absorbent core 42, and a fastener 44 for attaching the sanitary napkin to the wearer's panties. The absorbent core 42 is positioned between the topsheet 38 and the backsheet 40.

The sanitary napkin 20 of the present invention can also be provided with any optional additional components. The optional components may include, but are not limited to one or more wicking layers 46 (such as the acquisition layer or the "secondary topsheet" shown in FIG. 6), an optional interliner 48 (FIG. 51), side flaps 52 (FIG. 5), and a removable cover strip or release liner 50 (FIG. 2). The wicking layer 46 may be positioned between the topsheet 38 and the absorbent core 42. As shown in FIG. 51, the optional interliner 48 is positioned between the absorbent

13

core 42 and the backsheet 40. The side flaps or "wings" 52 are folded around the crotch portion of the wearer's panties. (The wearer's panties or undergarments are designated U in the drawings.) The removable release liner 50 covers the fasteners 44 when they comprise adhesives. This keeps the adhesives from sticking to surfaces other than the crotch portion of the undergarment prior to use of the sanitary napkin 20.

The extensibility of the sanitary napkin 20 is shown in Figure 4. The term "extensible", as used herein refers to articles that can increase in at least one of their dimensions in the x-y plane. The x-y plane is a plane generally parallel to the faces of the sanitary napkin 20. The term extensible includes articles that are stretchable and elastically stretchable (defined below). The sanitary napkin 20 shown in Figure 4 is preferably extensible both in length and width. The sanitary napkin 20, in other embodiments however, may only be extensible in one of these directions. Preferably, the sanitary napkin 20 is extensible at least in the longitudinal direction.

The sanitary napkin 20 may in some preferred embodiments, in addition to being extensible, also be stretchable. The term "stretchable", as used herein, refers to articles that are extensible when stretching forces are applied to the article and offer some resistance to stretching.

More preferably still, the sanitary napkin 20 may be elastically stretchable. The terms "elastically stretchable" or "elastically extensible" are intended to be synonymous. These terms are illustrated in Figure 4. These terms, used herein, mean that when the stretching forces designated "F" are removed, the sanitary napkin will tend to return toward its unextended or unstretched dimensions (or "original" dimensions) L_U and W_U . The sanitary napkin 20 need not return all the way to its unstretched dimensions, however. It may, as shown in Figure 4, return to relaxed dimensions (such as L_R and W_R) between its unstretched dimensions and extended (or stretched dimensions) L_S and W_S .

14

Making the sanitary napkin elastically stretchable will reduce the undesirable tendency of the sanitary napkin to gather longitudinally inward (i.e., bunch longitudinally) when forces which tend to stretch the sanitary napkin are removed. This is particularly true when the wearer's panties contract.

2. Extensibility of Preferred Sanitary Napkin Embodiments.

A. Introduction.

The sanitary napkin 20 can be in the form of many different embodiments.

These embodiments may be placed into at least four general categories for purposes of discussion. The first category deals with the type of forces used to extend the sanitary napkin. The first category is comprised of two sub-categories: (a) sanitary napkins that depend on manipulation by the user for their extensibility; and (b) sanitary napkins that need only be subjected to the typical forces encountered during use for their extensibility. Both types of sanitary napkins are within the scope of the present invention.

A second category is based upon whether or not an appreciable amount of force is required to extend the sanitary napkin. The sanitary napkin embodiments in the second category can be categorized as: (a) sanitary napkins that require some appreciable amount of force to extend; and (b) sanitary napkins that can be extended with very little force. Both types of sanitary napkins are within the scope of the present invention.

The third category relates to which components of the sanitary napkin are extensible. The sanitary napkin embodiments in the third category fall into two basic sub-categories: (a) sanitary napkins that are comprised of all extensible components; and (b) sanitary napkins that are comprised of some extensible

components and some inextensible components. Examples of sanitary napkins in the second sub-category include, but are not limited to: (i) sanitary napkins having an extensible backsheet with an inextensible topsheet and absorbent core; and (ii) sanitary napkins having an extensible topsheet and backsheet that form an extensible bag around an inextensible absorbent core.

The fourth category relates to whether the sanitary napkin is generally extensible, or is generally inextensible and is associated with some type of extensible element. The fourth category is comprised of at least two sub-categories: (a) sanitary napkins that are provided with extensible components; and (b) sanitary napkins adapted to extend by associating them with some type of extensible element. Examples of the second sub-category are sanitary napkins with extensible attachment elements. Again, both types of sanitary napkins are within the scope of the present invention.

The categories may encompass subject matter that overlaps into other categories. Other categories and sub-categories exist as well. The overall extensibility characteristics are described below. It should be understood, however, that the overall extensibility characteristics will often depend on the sub-categories into which the sanitary napkin falls.

B. Extensibility Characteristics.

(1) Amount of Extensibility.

The sanitary napkin 20 is preferably capable of extending between about 110% to about 150% of its unextended length (and its unextended width). (That is, the sanitary napkin is capable extending between about 10 or 15% and about 50%.) More preferably, sanitary napkin 20 is capable of extending between about 120% to about 140% of its unextended length (and width). In other embodiments, the sanitary napkin 20 (or portions thereof) may be capable of extending greater or lesser amounts.

The amount of extensibility preferably corresponds to the amount the wearer's panties can stretch. In other words, during wear the sanitary napkin 20 preferably extends about the same amount as the wearer's panties. It has been found that 20% stretch is adequate to account for most stretch induced to the wearer's panties by body motions.

The forces required to extend the sanitary napkin and the other parameters associated with the extensibility of some preferred embodiments of the sanitary napkin 20 are summarized in the table in FIG. 8. The forces and other parameters in Table 1 (as noted above) are those associated with several preferred sanitary napkin embodiments.

It is to be understood that absorbent articles having parameters that fall outside of those shown in Table 1 may also fall within the scope of the present invention in some circumstances. It is also to be understood that all of the limits and ranges specified herein include all narrower ranges and limits that are within the specified limits and ranges. Thus, for example, if a range is specified as being between about 125% and about 150%, all narrower ranges, such as between about 130% and about 140%, and between about 130% and about 150%, etc., may be claimed even though these limits and ranges are not separately listed. The forces are measured in accordance with the Test Methods described in Section 5 of this description.

The table first provides values for the forces required to extend the sanitary napkin in the longitudinal direction. The sanitary napkin should preferably extend under the naturally occurring forces that cause the wearer's panties to stretch and move when the wearer moves. This will allow the sanitary napkin to stretch with the wearer's panties. The values in the table represent those forces.

The percentages of longitudinal extension provided above (and other measurements in Table 1) are measured along the longitudinal centerline L of the sanitary napkin 20. Some portions of the

17

sanitary napkin 20 may, however, extend more (or develop a force wall after greater extension) than the portions of the sanitary napkin that lie along the longitudinal centerline L.

Figure 8A shows that the portions of the sanitary napkin along the longitudinal edges 22 of the sanitary napkin 20 may extend more than the portions lying along the longitudinal centerline L. In this embodiment, the panty fasteners 44 on the garment-facing side of the sanitary napkin are affixed closely to the leg elastics of the wearer's panties, particularly in the corner regions 27. This greater extension occurs when the leg elastics of the wearer's panties stretch more than the portions of the panties underlying the longitudinal centerline of the sanitary napkin.

Figure 8A shows that the portions of the sanitary napkin lying along the longitudinal centerline L extend a distance "C". The portions of the sanitary napkin 20 lying along the longitudinal side edges 22 extend a greater distance "D". These portions of the sanitary napkin 20 lying along the longitudinal side edges 22 may extend up to 175% - 200% of their unextended length.

The table in FIG. 8 indicates that the sanitary napkin may also (or alternatively) be extensible in width. Further, FIG. 8 also indicates that the sanitary napkin may have an elastic "wall" (or "force wall") such that at a certain point, the forces required to further increase the length and/or width of the sanitary napkin greatly increase. These parameters are discussed more fully below.

The portions of the sanitary napkin which are capable of extending the amounts described herein, should preferably contain some absorbent material. The absorbent material is preferably capable of holding at least about 0.05 gram of liquid per square cm. This is measured by dipping the absorbent material into distilled water, removing the sample from the water, and allowing

18

the sample to drip for 30 seconds. This absorbent material may be absorbent core material. Preferably, the absorbent material that is capable of extending comprises more than a single web of absorbent topsheet material.

An example of an embodiment which does not have absorbent material capable of extending is one in which the topsheet and backsheet extend (but are nonabsorbent), but the absorbent core does not. (Such an embodiment is not preferred because the extensible components do not include absorbent material. However, such a construction would still provide a degree of additional area coverage of the wearer's panties when extended.)

(2) Force to Extend

The set of figures in the second column of Table 1 are the amounts of force required to extend the sanitary napkin longitudinally. A set of figures is given for extending the sanitary napkin 25% and 40%.

The sanitary napkin will preferably extend at least 25% of its length under forces of less than or equal to about 800 grams, preferably less than or equal to about 400 grams, and most preferably less than or equal to about 300 grams.

The sanitary napkin will preferably extend about 40 percent of its length under forces of less than or equal to about 1250 grams. More preferably, the sanitary napkin will extend about 40 percent of its length under forces of less than or equal to about 800 grams. The sanitary napkin will (although not specified in Table 1) most preferably extend about 40 percent of its length under forces of less than or equal to about 600 grams.

The set of figures in the third column of the table are the amounts of force required to stretch the sanitary napkin across its width (in terms of the test described later which utilizes a

1.0 inch strip sample). The table is read in the same manner as for the longitudinal stretch.

The sanitary napkin 20 may be extensible only in length or width. The sanitary napkin need not be extensible both longitudinally and in width.

There are also some embodiments of the sanitary napkin of the present invention that may not fall within the ranges in the table. The sanitary napkin with the pull-out tab described in Section 4A below is a non-limiting example of such a sanitary napkin. The sanitary napkin with the pull-out tab is designed to be extended by sliding out or folding out a tab, rather than by stretching a component of the sanitary napkin 20. The sanitary napkin with a pull-out tab falls into the category of sanitary napkins that can be extended with very little resistance. The sanitary napkin with the pull-out tab, and certain other embodiments are still within the scope of the present invention even though they may fall outside some of the parameters set out in the table.

(3) Minimum Force to Extend

A minimum force to extend the sanitary napkin any appreciable distance (e.g., 5%, or more preferably 10%) is desired so that the sanitary napkin is easy to handle. A sanitary napkin with too low of a modulus of elasticity (that is, one that stretches too easily) is difficult for the user to handle and place into the panty. Such a sanitary napkin tends to become "stringy" similar to taffy.

Preferably, a force of at least about 50 grams is required for the sanitary napkin to extend about 25% and a force of at least about 100 grams is required to extend the sanitary napkin about 40%. In more preferred embodiments, a force of at least about 100 grams will be required to extend the sanitary napkin about 25%.

(4) Force Wall 20

The sanitary napkin 20 preferably exhibits a stress-strain curve for longitudinal or lateral extension similar to that shown in FIG. 9.

The sanitary napkin preferably extends relatively easily up to a desired amount, then develops a force wall which prevents further extension under the forces normally encountered by the sanitary napkin during use and removal.

The sanitary napkin need not have a force wall in all embodiments. Further, in embodiments where a force wall is provided, the force wall may only be provided to prevent further increases in the length or width of the sanitary napkin.

Typically, it is more important to provide a force wall to prevent further increases in length. This is because the sanitary napkin may be subjected to the greatest stretching forces along its length.

The sanitary napkin is subjected to relatively large stretching forces in the longitudinal direction during removal of the napkin from the wearer's panties. A force wall prevents the sanitary napkin from stretching excessively during removal of the sanitary napkin from the wearer's panties. In addition, a force wall may be desirable since the length of the sanitary napkin is greater than its width, and, therefore, the sanitary napkin is capable of stretching a greater amount in the longitudinal direction than in the transverse direction.

Such a force wall may include, but is not limited to those which are intrinsic in the materials used in the components of the sanitary napkin 20 and those created as a result of its construction where mechanical "stops" are placed into the sanitary napkin to prevent extension beyond a certain point.

21

The first type of force wall can, for example, be seen in a hypothetical film. The film may produce a force wall when stretched to a certain limit. For instance, the film may extend about 10% (i.e., 110% of its original dimensions) before reaching a point where it cannot be stretched further without substantial force. Typically, however, the film will have to be subjected to forces in excess of those desired herein to achieve this initial 10% extension unless it is made extensible as described herein.

FIG. 10 shows an example of a mechanical "stop" 54. The schematic drawing depicts an extensible component 56. The extensible component 56 could, as a non-limiting example, comprise an extensible absorbent core or an extensible backsheet. The extensible component 56 has either an inextensible or less extensible restraining element 58 attached to it. The restraining element 58 is attached so that it is provided with slack or flaccid material which allows the core or backsheet to extend to a specified length, but no further without an appreciable amount of force.

FIG. 11 shows an example of a laminate structure that can be used to provide the sanitary napkin with a stop or force wall. The example shown could represent the backsheet. The backsheet 40 could be a laminate comprised of a stretch laminate film, such as stretchable adhesive film 60 laminated to a pre-stretched polyethylene film 62. The two films are laminated together when the pre-stretched film 62 is relaxed. When the backsheet 40 is stretched, it will easily stretch up to the pre-stretched length of the polyethylene film 62, but will extend no further without substantial force.

The laminate structures that are used to provide the sanitary napkin with a stop or force wall need not be bonded across the entire interface between the component parts of the laminate.

For example, a laminate could be formed of a pre-stretched material, such as an elastic film and an absorbent material. the

22

absorbent material could be intermittently bonded to the pre-stretched film when the film is in its stretched condition. The two components could be bonded at a plurality of lines, spots, or other locations. The components could be bonded by glue, thermal bonds, or any other suitable type of bond.

The resulting laminate will form puckered areas when it is relaxed. It can have unidirectional stretch, bi-directional stretch, or multi-directional stretch. The laminate will be able to extend to the pre-stretched dimensions of the elastic film, but will extend no farther without substantial force. The laminate thus formed could be used as a combination structure that serves as one or more of the basic components of the sanitary napkin.

(5) Amount of Recovery (or Percent Set)

The amount of recovery of the sanitary napkin can vary in different embodiments. Thus, upon extension to 125% or to 140% of its original length, the sanitary napkin need not return to its original length when the extending load is released. However, it is preferable if the sanitary napkin returns to less than 110% of its original length so that when the sanitary napkin extends, it will return as the panty material relaxes and/or the wearer's body moves, and will not bunch. Table 1 shows that in less preferred embodiments, the sanitary napkin may return to up to less than or equal to 125% of its original length when the extending load is released.

(6) Rate of recovery

If the sanitary napkin has the capability of recovering toward its unstretched dimensions, it preferably has a relatively low rate of recovery. A relatively low rate of recovery is desirable for several reasons.

The sanitary napkin will fit best against the wearer's body when it slowly returns toward its unextended dimensions after it is stretched. The sanitary napkin can be gently held against the

wearer's body and in conformity therewith by the forces that tend to return the sanitary napkin toward its unextended dimensions. The sanitary napkin can also have regions that, due to creep of the same, may not tend to return toward their original dimensions. These regions may also aid body fit. Thus, the sanitary napkin can be contrasted with conventional elastic materials such as LYCRA that have substantial tendencies to retract.

A rapid recovery rate also makes the sanitary napkin undesirable from a consumer viewpoint in removing the sanitary napkin from the panty. After use, the user will often rip the sanitary napkin out of the crotch region of her panties in a fairly aggressive manner. If the rate of recovery is too high, the sanitary napkin may tend to snap back toward the user during removal (i.e., like a rubber band). This is particularly important when the longitudinal extension of the sanitary napkin is greater than or equal to about 20%.

The rate of recovery should be high enough, however, so the sanitary napkin will return to its recovered length or width within a few seconds (i.e., less than or equal to about 5 seconds).

Preferably, the sanitary napkin will return to its recovered length or width at a rate in the range of about 0.5 inches/sec. (about 1.3 cm./sec.) to about 2 inches/sec. (about 5 cm./sec.).

3. The Individual Components of the Sanitary Napkin.

The individual components which may be suitable for various embodiments of the sanitary napkin 20 of the present invention will now be looked at in greater detail with reference to FIGS. 1-3.

A. The Topsheet

(1) General Characteristics of Preferred
Topsheet Materials.

The topsheet 38 comprises a first liquid pervious component. When the sanitary napkin 20 is in use, the topsheet 38 is in close proximity to the skin of the user. The topsheet 38 is preferably as compliant, soft feeling, and non-irritating to the user's skin as possible. The topsheet 38 should further exhibit good strikethrough and a reduced tendency to rewet, permitting bodily discharges to rapidly penetrate it and flow toward the core 42, but not allowing such discharges to flow back through the topsheet 38 to the skin of the wearer.

The topsheet 38 has two sides (or faces or surfaces), including a body-facing side 38A and a garment-facing side (or core-facing side) 38b. The body-facing side 38A of the topsheet 38 generally forms at least a portion of the body-contacting surface ("body surface") 20A of the sanitary napkin 20. The topsheet 38 has two longitudinal edges 38C and two end edges 38D.

(A similar numbering system will be used for the other components of the sanitary napkin. That is, the side of the component facing the wearer's body will be designated by the number of the component and a reference letter "A". The side facing the wearer's undergarments will be designated by the number of the component and the letter "B". The side and end edges will be designated by the number of the component and the reference letters "C" and "D" respectively.)

A suitable topsheet 38 may be manufactured from a wide range of materials including, but not limited to woven and nonwoven materials, apertured formed thermoplastic films, apertured plastic films, hydro-formed films, porous foams, reticulated foams, reticulated thermoplastic films, and thermoplastic scrims.

Suitable woven and nonwoven materials can be comprised of natural fibers (e.g., wood or cotton fibers), synthetic or modified natural fibers (e.g., polymeric fibers, such as

25

polyester, polypropylene fibers, and polyethylene, or polyvinylalcohol, starch base resins, polyurethanes, cellulose esters, nylon, and rayon fibers) or from a combination of natural and synthetic fibers.

When the topsheet 38 comprises a nonwoven web, the web may be spunbonded, carded, wet-laid, meltblown, hydroentangled, combinations of the above, or the like.

Apertured films are generally preferred for the topsheet 38 because they are pervious to liquids and, if properly apertured, have a reduced tendency to allow liquids to pass back through and rewet the wearer's skin. Suitable apertured films can be made of any of the materials specified in the publications that describe films and methods of making films which are incorporated by reference herein.

Suitable films are described in U.S. Patent 3,929,135 issued to Thompson on December 30, 1975, U.S. Patent 4,324,426 issued to Mullane et al. on April 13, 1982, U.S. Patent 4,342,314 issued to Radel et al. on August 3, 1982, U.S. Patent 4,463,045 issued to Ahr, et al. on July 31, 1984, and U.S. Patent 5,006,394 issued to Baird on April 9, 1991. Additional suitable formed and hydro-formed films are described in U.S. Patents 4,609,518, 4,629,643, 4,695,422, 4,772,444, 4,778,644, and 4,839,216 issued to Curro, et al., and in U.S. Patent 4,637,819 issued to Ouellette, et al.

Still other materials suitable for use as a topsheet are described in U.S. Patent 4,775,579 issued to Hagy, et al. on October 4, 1988, U.S. Patent 4,798,604 issued to Carter on January 17, 1989, U.S. Patent 5,023,124 issued to Kobayashi on June 11, 1991, and in European Patent Application 0 304 617 A2 published March 1, 1989 in the name of Suda, et al.

In still other embodiments, the materials described in some of the above references (such as the stretchable polymeric materials described in U.S. Patent 4,798,604 issued to Carter)

could be made into the films described in other references. For instance, the stretchable polymeric materials described in U.S. Patent 4,798,604 could be made into the macroscopically expanded three dimensional plastic film having a substantially non-glossy surface described in U.S. Patent 4,463,045.

In another embodiment shown in Figure 12, the topsheet 38 could comprise a structure comprising a nonwoven material or fabric 64 and an apertured film such as three dimensional apertured plastic film 66. The nonwoven material provides the topsheet with an improved, less plastic-like feel.

In one preferred version of the embodiment shown in Figure 12, the nonwoven material 64 has a basis weight from about 1 to about 40 g/sq. m., more preferably from about 8 to about 12 g/sq. m. One preferred nonwoven material comprises a carded thermally dot bonded polypropylene web. Some preferred nonwoven fabrics are Manufactured by the Fiberweb Group of Simpsonville, South Carolina under the trademarks CELESTRA™ and HOLMESTRA.™

The plastic film 66 is a thermoplastic material provided with a multiplicity of tapered capillaries 39 in a manner, size, configuration, and orientation set forth in U.S. Patent 3,939,135 issued to Thompson. The film is treated with a surfactant such as ATMER™ 645 manufactured by ICI Speciality Chemicals. Preferably, the surfactant is incorporated into the polyolefin resin pellets from which the film is made.

The nonwoven fabric 64 and the apertured plastic film 66 may be integrally formed into a composite structure such as that shown in FIG. 12 by embedding the fibers of the nonwoven material into the thermoplastic film when the latter is in a molten condition using a vacuum lamination process. Such a topsheet is described in greater detail in Canadian Patent Application Serial No. 2,123,904 filed by Aziz, et al. On October 30, 1992. In alternative embodiments, the nonwoven fabric and the film may be placed into a face-to-face relationship. The two components are preferably

secured to each other in these latter embodiments. Suitable methods for securing the two components include, but are not limited to adhesives, fusion including heat bonding and/or pressure bonding, ultrasonics, and dynamic mechanical bonding.

Figure 13 shows that in still other embodiments, the topsheet 38 may comprise a fiber-entangled film. The term "fiber-entangled film" refers to apertured films having fibers entangled in and around their apertures.

The apertured film 68 of such a topsheet could comprise any of the films or scrims described herein. One particularly suitable apertured film 68 for use in such a topsheet is disclosed in U.S. Patent 4,463,045 and ring-rolled (as described below) to provide it with a degree of extensibility. The film 68 can be ring rolled before or after the entanglement of the fibers.

The film 68 has nonwoven fibers 70 loosely mechanically or thermo-mechanically entangled therewith. The fibers 70 are preferably entangled along or from the direction of either the body-facing side 38A, or the core-facing side 38B.

The fibers 70 could be mechanically or thermo-mechanically entangled with the film 68 by any suitable process. For instance, the fibers 70 could be meltblown onto the film, spunbonded onto the film, carded onto the film, thermo-mechanically entangled with the film such as being flocked or meltblown on the plastic film while the film is still in its molten state, or hydro-entangled with the film. One suitable meltblowing process is disclosed in Exxon U.S. Patent 3,978,185 issued to Buntin, et al.

The fibers 70 may be either hydrophilic or hydrophobic. Suitable hydrophilic fibers may be formed from intrinsically wettable fibers such as nylon co-polymers comprising a nylon component and a hydrophilizing component. Such a material is commercially available from Allied Signal Inc. under the trade-mark Hydrofil SCFX.TM

In a preferred embodiment, the fibers 70 are of a thermoplastic synthetic nature. Suitable polyethylene fibers are available from the Dow Chemical Company under the trade-mark ASPUN,[™] and polypropylene fibers are available from the Exxon Corporation under the trade-mark ESCORENE[™] 3,400 and 3,500 series.

Once formed, the fiber-entangled film structure is preferably treated by any known methods to render it hydrophilic. Such process will allow the apertures 39 of the film to better handle liquids. The composite structure may be ring-rolled after these treatment processes.

The fiber-entangled topsheet 38 material provides more intimate contact between the apertured film 68 and the nonwoven fibers 70. This can create advantages of improved liquid transport through the film 68 to the fibers 70 and the underlying layers. It may also provide improved comfort if the fibers lie along the body-facing side 38A of the topsheet 38. It can also provide improved comfort when fibers lie along the core-facing side 38B of the topsheet 38 since the film 68 portion of the topsheet 38 will be less likely to separate from the underlying entangled fibers 70 and move into the crevices of the wearer's body.

(2) Alternative Ways of Providing the Topsheet With Extensibility.

There are several basic ways of providing the topsheet materials described above with extensibility. A non-limiting number of these ways are described below.

One way of making the topsheet 38 extensible is by performing a mechanical operation, such as pleating, corrugating, or ring rolling on the topsheet material to provide folds in the topsheet that are able to open when the topsheet is stretched. Such a process can be performed on many of the topsheet materials described above.

In one preferred embodiment of the present invention, the topsheet 38 is made in accordance with U.S. Patent 4,463,045 and ring rolled to provide it with a degree of longitudinal extensibility.

Such a topsheet is described in the following patent applications; Canadian Patent Application Serial No. 2,073,815 filed July 14, 1992 in the names of Thompson, et al.; Canadian Patent Application Serial No. 2,073,849 filed July 14, 1992 in the names of Thompson, et al.; and, Canadian Patent Application Serial No. 2,113,416 filed July 6, 1992 in the names of Buenger, et al. These patent applications may be referred to collectively as the "Capillary Channel Fiber" patent applications.

Suitable processes for ring rolling or "pre-corrugating" are described in U.S. Patent 4,107,364 issued to Sisson on August 15, 1978, U.S. Patent 4,834,741 issued to Sabee on May 30, 1989 and in commonly assigned Canadian Patent Application Serial No. 2,103,822 filed January 28, 1992 by Gerald M. Weber et al., Canadian Patent Application Serial No. 2,101,277 filed by Kenneth B. Buell et al. on January 28, 1992, and Canadian Patent Application Serial No. 2,104,236 filed by Gerald M. Weber et al. on January 28, 1992 (collectively referred to herein as the "Ring Rolling" patent applications).

The fold lines in the corrugations of a ring rolled topsheet should run in the transverse direction so the topsheet is longitudinally extensible. In other embodiments, the fold lines could run in the longitudinal direction, both directions, and/or other directions. The topsheet 38 will be extensible in directions perpendicular to the fold lines.

29a

Figure 14 shows that in other embodiments, the topsheet 38 could be comprised of a nonwoven material having fibers 78 generally oriented in a direction perpendicular to the direction

of the desired stretch. The topsheet, for instance, could be comprised of fibers generally oriented in the transverse direction to provide extensibility in the longitudinal direction.

Figure 15 shows another alternative topsheet embodiment. In Figure 15, the topsheet 38 is bonded to an underlying acquisition layer 46 by the type of individual fusion bonds 72 shown in Figure 5. In the embodiment shown in Figure 15, the acquisition layer 46 is stretched before it is fused to the topsheet 38. The topsheet 38 and acquisition layer 46, thus, form a laminate. When the stretched laminate is relaxed, the laminate has tufted areas 74 formed therein between bonded areas 72 and valleys 76 formed at the bonds.

The embodiment shown in Figure 15 provides a key advantage. It (and its various alternative embodiments) allows a stretchable laminate to be formed from materials that are not ordinarily thought of as being stretchable. The apertured plastic film topsheet 38, for instance, is not normally thought of as being extensible. However, the topsheet 38 is provided with a degree of extensibility when it is secured to a layer such as the acquisition layer 46 after the acquisition layer 46 has been extended and the two component materials are thereafter relaxed.

The tufted areas 74 in such a laminate can also provide certain benefits. The tufted areas 74 are typically soft. They will also place the absorptive fibers of the acquisition layer 46 closer to the wearer's body than the nontufted bonded areas. This construction may also enhance absorption (particularly at the tufted areas 74).

In other alternative embodiments, both the topsheet 38 and the acquisition layer 46 can be stretched prior to fusing the same together.

In other embodiments, the topsheet 38 can be made extensible by forming it from extensible, or more preferably, stretchable materials. The topsheet 38 can, for instance, be an apertured

31

film made of a polyethylene/Kraton blend such as Exxon film EXX-7 available from the Exxon Corporation. This will yield a stretchable material without any mechanical manipulation.

In other embodiments, the topsheet materials can include low basis weight nonwovens (nonwoven materials having a basis weight from about 18 to about 25 grams per square meter). An example of such a nonwoven material is manufactured by Veratec, Inc., a Division of International Paper Company, of Walpole, Massachusetts under the designation P-8.

In other embodiments, the topsheet could be comprised of a thermo-formed mass of fibers or hydroentangled nonwovens.

Figure 16 shows that in still other embodiments, the topsheet 38 could have elastic structural components. One example of such a structure is a net, screen, or scrim 80 comprised of elastic ribs 82. An example of such a structure is disclosed in U.S. Patent 4,062,995 issued to Korpman December 13, 1977. The net could have square-shaped or diamond-shaped apertures 84 between its ribs. Such a structure is generally stretchable in all directions. Elastic or inelastic fibers 86 could be added or adhered to the net.

The topsheet 38 can, in still other alternative embodiments, be manufactured into a structure that is capable of stretching in more than one direction from materials that are only capable of stretching in one direction.

FIG. 17 shows an example of a process that can be used for this purpose. The left side of FIG. 17 shows a conventional process that could be used for cutting a web of stretchable material 88 into individual topsheets 38. The web 88 runs in the machine direction (MD). This is also the direction the web 88 stretches.

32

The right side of FIG. 17 shows a process of creating a multi-directional stretch topsheet by cutting the web of stretchable material at an angle (or on a "bias" to the machine direction). In a variation of this process, the web could be fed in at an angle and cut in the same direction as shown in the conventional process. The resulting cut topsheet 38 will be able to stretch in two directions as shown by the arrows near the cut topsheets.

Figure 17A shows that in still other embodiments, an apertured film topsheet 38 can be provided with apertures 39 having a geometry that is conducive to allowing the topsheet 38 to stretch in a particular direction.

In still other embodiments, the topsheet 38 could be slit for extensibility as described below for the absorbent core.

In still other embodiments (shown in FIG. 17B), the topsheet 38 can comprise a reversibly necked material. Reversibly necked materials generally comprise materials that increase in width (rather than decrease) when extended longitudinally. Such materials are useful in sanitary napkins because they are not subject to the reduction in their ability to cover a given area of the crotch of the wearer's panties when the sanitary napkin is stretched. In fact, their ability to cover the crotch area will increase when they are stretched. As shown in Figure 17B, if this increase in width is great enough, these materials can be used to form flap-like structures when the sanitary napkin is stretched.

One suitable way of creating a reversibly necked material is described in U.S. Patent 4,965,122 issued October 23, 1990 to Morman.

(3) Additional Steps.

In addition to the above, in preferred embodiments of the present invention, at least a portion of the topsheet 38 is

treated with a surfactant. This can be accomplished by any of the common techniques well known to those skilled in the art.

Suitable methods for treating the topsheet 38 with a surfactant are described in a number of references, including U.S. Patents 4,950,264 and 5,009,653 issued to Osborn, and in Canadian Patent Application Serial No. 2,123,904 filed by Aziz, et al. on October 30, 1992. The latter patent application teaches treating the apertured film component of a nonwoven/apertured thermoplastic formed film topsheet with a surfactant. The surfactant is preferably incorporated into the resin used to make the thermoplastic formed film.

Treating the topsheet 38 with a surfactant renders the topsheet 38 more hydrophilic. This results in liquid penetrating the topsheet 38 faster than it would if the surface were not treated. This diminishes the likelihood that body fluids will flow off topsheet 38 rather than being drained through the topsheet 38.

In addition, in preferred embodiments, the inner surface 38B of topsheet 38 is secured in contacting relation with an underlying absorbent layer. This contacting relationship results in liquid penetrating topsheet 38 faster than if the topsheet 38 were not in contact an absorbent component. However, it is not absolutely necessary to bond the face of the topsheet 38 to the face of the underlying layer.

The topsheet 38 can be maintained in contact with an underlying absorbent component by applying adhesives between the topsheet and the underlying component, by entangling the fibers of the underlying layer with the topsheet, by fusing the topsheet 38 to an underlying absorbent layer by a plurality of discrete individual fusion bonds, or by any means known in the art.

FIGS. 5 and 7 show a preferred type of fusion bond which forms bonded areas which provide structures with drainage

passageways for liquids to pass through to the underlying absorbent material. These preferred fusion bonds are described in greater detail in Canadian Patent Application Serial No. 2,124,798 filed in the names of Cree, et al. on November 6, 1992.

B. The Absorbent Core

(1) General Characteristics of Preferred Absorbent Core Structures.

The absorbent core 42 is positioned between the topsheet 38 and the backsheet 40. The absorbent core 42 provides the means for absorbing menses and other body fluids.

The absorbent core 42 need not have an absorbent capacity much greater than the total amount of fluid anticipated to be absorbed. The absorbent core 42 is generally compressible, conformable, and non-irritating to the user's skin. It can comprise any material used in the art for such purpose. Non-limiting examples include natural materials such as comminuted wood pulp which is generally referred to as airfelt, creped cellulose wadding, hydrogel-forming polymer gelling agents, modified cross-linked cellulose fibers (described below), capillary channel fibers, absorbent foams, absorbent sponges, synthetic staple fibers, polymeric fibers, peat moss, or any equivalent material or combinations of materials.

The polymeric gelling agents listed above may also be referred to as "absorbent gelling materials" or "superabsorbent materials". Polymeric gelling agents are those materials which, upon contact with liquids such as water or other body liquids, imbibe such liquids and thereby form hydrogels. In this manner, liquids discharged into the absorbent core 42 can be acquired and held by the polymeric gelling agent, thereby providing the articles herein with enhanced absorbent capacity and/or improved liquid retention performance.

The polymeric gelling agent which is employed in the absorbent core 42 will generally comprise particles 41 of a substantially water-insoluble, slightly cross-linked, partially neutralized, hydrogel-forming polymer material. The term "particles", as used herein, can refer to particles in any form, such as in the form of pellets, flakes, or fibers.

The general characteristics of one basic type of absorbent core 42 (including, but not limited to the preferred types of polymer materials used therein, and types of methods which can be used for preparing these polymer particles) are described in greater detail in U.S. Patent 5,009,653 issued to Osborn and the patents incorporated by reference in that patent, the disclosures of which are all incorporated by reference herein. (The absorbent cores 42 described herein need not include superabsorbent material particles, however.)

Suitable cross-linked cellulose fibers for the absorbent core are described in U.S. Patent 4,888,093, issued December 19, 1989 to Cook, et al.; U.S. Patent 4,822,543, issued April 18, 1989 to Dean, et al.; U.S. Patent 4,889,595, issued December 26, 1989 to Schoggen, et al.; U.S. Patent 4,898,642, issued February 6, 1990 to Moore, et al.; and U.S. Patent 4,935,022 issued June 19, 1990 to Lash et al.; EPO Patent Application Publication Nos. 0 427 316 A2 and 0 427 317 A2 published in the name of Herron, et al. on May 15, 1991; and EPO Patent Application Publication No. 0 429 112 A2 published in the name of Herron, et al. on May 29, 1991.

Suitable capillary channel fibers (that is, fibers having channels formed therein, preferably, on their exterior surfaces) for the absorbent core are described in greater detail in the Examples provided below, in EPO Patent Application 0 391,814 published October 10, 1990, and in the aforementioned Capillary Channel Fiber patent applications.

Suitable absorbent cores comprising foams are described in Canadian Patent Applications Serial Nos. 2,114,958, 2,114,957, and 2,114,523

The first and third applications listed were filed in the names of DesMarais, et al. The second application listed was filed in the name of Young, et al. The three applications were filed on August 7, 1992. Additional cores comprising foams are described in European Patent Application 0 293 208 B1.

Absorbent cores comprising sponges are described in U.S. Patents 3,512,530, 3,954,493 and French Patent 2,203,827.

Additional suitable absorbent cores that can be provided with extensibility are described in the following references: U.S. Patents 4,773,903 and 4,865,596 issued to Weisman, et al. on September 27, 1988 and September 12, 1989, respectively. These patents disclose composite absorbent structures comprising webs of entangled blown microfibers, substantially nonabsorbent crimped staple fibers, particles of hydrogel-forming polymeric gelling agents and a hydrophilizing agent.

Other suitable absorbent core materials comprise mixtures of melt blown elastic fibers and absorbent materials. One such core material comprises a hydro-entangled composite of cotton and melt blown fibers known as product #7102-102 available from Fiberweb of Simpsonville, South Carolina. In other embodiments, the cotton could be replaced with other absorbent materials such as FSA™ fiber Type 101 or 102 available from Courtaulds Fibers, Ltd. West Midlands, England. Alternatively, two plies of a material such as the above product #7102-102 could be laminated together with a particulate polymeric gelling agent in between and provided with extensibility to produce a highly absorbent extensible laminate.

In addition, the absorbent core 42 can be comprised of many materials described herein as being suitable for use as topsheets. In order to be suitable, however, these materials must be absorbent or used in conjunction with some absorbent material. For instance, the absorbent core 42 could be comprised of a structure similar to the elastic scrim shown in Figure 16 with absorbent fibers adhered thereto.

(2) Providing the Absorbent Core With Extensibility.

There are many possible extensible absorbent core embodiments. These include, but are not limited to the embodiments described below. The components of the embodiments described below can also be combined in any suitable manner to form additional embodiments.

(a) Laminates

In one preferred embodiment shown in Figure 2, the absorbent core 42 is a laminate. The laminate is comprised of a layer of superabsorbent polymer material, such as in the form of particles 41, disposed between two air-laid tissues, first and second tissue layers (or "upper" and "lower" tissue layers) 43 and 47, respectively.

The first and second tissue layers 43 and 47 provide containment of the superabsorbent polymer material, improve lateral wicking of the absorbed exudates throughout the absorbent core 42 and provide a degree of absorbency. The tissue layers 43 and 47 can be comprised of a single tissue web which is folded with the superabsorbent material particles 41 between, or two separate sheets of the same (or different) tissue.

A suitable laminate is a superabsorbent laminate known as WATER-LOCK L-535 available from the Grain Processing Corporation of Muscatine, Iowa (WATER-LOCK™ registered TM by Grain Processing Corporation). Such superabsorbent laminates are disclosed in U.S. Patent 4,467,012, issued to Pedersen et al. on August 21, 1984, U.S. Patent 4,260,443, issued to Lindsay et al. on April 7, 1981, and U.S. Patent 4,578,068 issued to Kramer, et al. on March 25, 1986.

The laminate absorbent core 42 can be made extensible by making the same from tissue paper having between 20% and 200% stretch (i.e., capable of extending between about 120% and 300% of its original length). Such tissue sheets can be made by a number of processes. The tissue paper may in one embodiment, be conventionally creped tissue. For example, the tissue paper may be a BOUNTY tissue that is run through a creping process.

In other embodiments, the tissue may be made by a suitable variation of the process described in U.S. Patent 4,191,609 issued to Trokhan on March 4, 1980, or by a suitable variation of the processes described in U.S. Patent 4,529,480 issued to Trokhan on July 16, 1985, or the processes described in European Patent Application Publication Nos. WO 92/00414, WO 92/00415, and WO 92/00416 published January 9, 1992. In the latter cases, the tissue may be made extensible by one or more of the following procedures: adjusting the angle of the doctor blade to provide additional creping; tailoring the characteristics of the paper's network region to allow a certain amount of stretch; or, by removing the paper web from the Yankee dryer earlier than ordinary before it is subjected to further drying to give it a creped effect.

In alternative embodiments, a tissue with no or very low initial crepe can be creped after lamination. The creping process in this case could occur by passing the laminate through two matched rolls such that they would yield a corrugated laminate tissue with stretch in the range of 20% to 200% (capable of extending between about 120% and 300% of its original length). The corrugations should be perpendicular to the direction of desired stretch.

In a related alternative embodiment, the laminate could be creped by adhering the laminate to a surface and creping the laminate off the surface. This could be done in a manner similar to the step of removing the paper web from a Yankee dryer described in the aforementioned EPO patent applications.

In another related embodiment, the laminate could be creped by pressing a pattern into it while the laminate is on a flat surface. For instance, a pair of flat plates could be used to impress a pattern into the laminate similar to that shown in U.S. Patent 4,578,068 issued to Kramer, et al.

In alternative embodiments, the laminate can be cut or slit to provide an extensible absorbent core structure. Figure 18 shows that in a particularly preferred embodiment, the absorbent core 42 is a laminate as described above which is slitted or partially slitted for longitudinal extensibility. FIG. 19 shows an alternate absorbent core that is slit at the central region, and not at the end regions. Figure 20 shows an alternate absorbent core that has diamond-shaped apertures cut therein. Any other suitable shape or shapes of apertures can be used.

Other types of slit absorbent materials are described in European Patent Application Publication Number 0 293 208 B1 published by Lion Corporation on July 24, 1991.

The longitudinal and end edges 22 and 24 of the sanitary napkin 20 are preferably sealed to prevent the wicking and expulsion of liquid or liquid-containing superabsorbent material from the napkin when it is extended. Alternatively, the edges 42c and 42d of the absorbent core 42 may be sealed rather than sealing the edges of the entire sanitary napkin. The edges of the core 42 may, for example, be wrapped or covered by a tissue layer. In other alternative embodiments, the edges of the tissue may be folded, or otherwise manipulated to prevent the wicking and expulsion of liquid or liquid-containing superabsorbent material particles 41 from the core 42. All permanent seals around the perimeter of the sanitary napkin 20 should not break upon lengthening (i.e., any seal is intended to remain for the duration of the use of the sanitary napkin.)

In any of the laminate absorbent core embodiments described above, a sheet of other any other known absorbent materials including, but not limited to peat moss, modified cross-linked

40

cellulose fibers, or synthetic fibers could replace the cellulose fibers in one or more of the tissue layers. The basis weights of the tissue layers could also be varied between layers.

(b) Structures Containing Mixtures of Absorbent Materials and Superabsorbent Materials.

The absorbent core 42 could, instead of comprising a laminate structure, be comprised of a mixture of the absorbent materials and superabsorbent materials described above.

For example, mixtures of superabsorbent materials with airfelt, modified cross-linked cellulose fibers cross-linked carboxy methyl cellulose such as that described in U.S. Patent 4,475,911 issued to Gellert on October 9, 1984, peat moss, or other absorbent materials can be used to make thin webs. These thin webs may then be creped, ring-rolled, slit, or otherwise manipulated as described herein to produce an extensible absorbent core 42.

The superabsorbent material particles 41 can be distributed in any known manner in any of the embodiments described herein. The superabsorbent material particles 41 may be homogeneously blended with the absorbent materials described herein. In other embodiments, the superabsorbent material particles can be distributed in a superabsorbent material concentration gradient in the sanitary napkin. Known manners for establishing such a concentration gradient are described in European Patent Application No. 0 198 683 published October 22, 1986 in the name of Duenk, et al., U.S. Patent 4,699,823 issued October 13, 1987 to Kellenberger, et al. and U.S. Patent 5,009,650 issued to Bernardin on April 23, 1991.

(c) Structures Containing Mixtures of Various Types of Fibers.

The absorbent core 42 can comprise a mixture of various types of natural or synthetic fibers and particular superabsorbent materials.

(i) The "Blended" Core.

Figures 21-23 show one particularly preferred absorbent core 42 that will be referred to as a "blended" core. This particular core arrangement is shown in a relatively thick sanitary napkin 20. It can, however, also be formed into a thin web for use in thin products.

The blended absorbent core 42 comprises a batt of fibers, preferably in the form of a homogeneous blend of fibers. The blended core 42 is comprised of at least two groups (or types) of fibers. These include a first group (or type) of low denier, relatively short, hydrophilic fibers, and from about 5% to about 90% of higher denier (and is preferably about 10%), longer synthetic fibers that comprise a second group (or type) of fibers. The blend ratio of the two groups of fibers can be varied to produce the properties desired for different types of absorbent articles. (All percentages specified in this description are by weight unless stated otherwise.)

The first group of fibers can comprise natural fibers such as cotton, cellulose, or other natural fibers. The first group of fibers can alternatively or additionally comprise synthetic fibers such as superabsorbent material fibers and capillary channel fibers, mechanically or chemically modified natural fibers, including but not limited to, rayon, chemical thermal mechanical pulp (or "CTMP" or TMP), ground wood, or cross-linked cellulose fibers. For one embodiment, the first group of fibers comprises airfelt. The fibers in the first group of fibers are either inherently hydrophilic, or they may be rendered hydrophilic by treating them in any of the manners described previously to render them hydrophilic.

Performance is improved by selecting a relatively stiff fiber which maintains a substantial portion of its compression resistance when wetted. (That is, the fibers should have a high

compressive modulus.) Preferably, the fibers selected are both compression resistant and wet and dry resilient (i.e., they tend to both resist compression and to spring back when compressed). Cross-linked cellulose fibers are especially preferred for these criteria. (It is understood, however, that cross-linked cellulose fibers are sufficiently modified that they may no longer be considered as either cellulosic, or as natural fibers, per se.)

The second group of fibers should also be of high compressive modulus and should maintain a relatively high modulus when wetted. The second group of fibers should also preferably be wet and dry resilient. Suitable fibers include, but are not limited to synthetic fibers comprised of any of those materials specified below as being suitable for use as the fibers of the acquisition layer 46. (Fiber lengths, denier, etc. are, however, not necessarily the same. Some preferred fiber lengths, etc. are described below.)

The fibers in the second group of fibers are preferably longer than the fibers in the first group of fibers. Preferably, the fibers in the second group of fibers are greater than or equal to about 1/4 inch (about 0.6 cm.) long, and are more preferably greater than or equal to about 1/2 inch (about 1.3 cm.) long. The denier of the fibers in the second group of fibers are preferably greater than the denier of the fibers in the first group of fibers. The fibers in the second group of fibers preferably have a denier per filament of between about 6 and about 40. More preferably, the denier is between about 15 and about 30, and most preferably between about 15 and about 25.

The fibers in the second group of fibers may be hydrophilic, hydrophobic, or partially hydrophilic and partially hydrophobic. The fibers in the second group of fibers preferably have at least some hydrophilic component (preferably a cellulosic component). The fibers in the second group of fibers can be provided with a hydrophilic component in a number of suitable ways. These include, but are not limited to coating or treating the fibers to render them, or at least their surfaces, hydrophilic.

Suitable synthetic fibers are available from Eastman Kodak Textile Fibers Division Kingsport, TN as the KODEL™ 200 and 400 Series. One suitable type of synthetic fiber is the KODEL 410 fiber.

One particularly suitable type of synthetic fibers for use in the second group of fibers are crimped polyester fibers. A suitable polyester fiber is the KODEL 431 fiber. These KODEL fibers are preferably crimped at a crimping frequency of between about 5 and 7, preferably about 6, more preferably 6.3 crimps per linear inch (i.e., per 2.5 cm.). The fibers are preferably crimped at a crimping angle of between about 70° to about 91°, preferably about 88°. Crimping provides the fibers with improved resilience, among other desired properties. The fibers have a denier of 15 per filament and a length of about 0.5 inch (about 1.3 cm.). They may be coated with a hydrophilic or hydrophobic finish by any suitable method known in the art.

In an alternative embodiment, it is possible to replace the cellulose fibers in the first group of fibers with very short, low denier, synthetic fibers (with hydrophilic surfaces). The blended core 42 in this situation would consist of short, low denier, hydrophilic first group of synthetic fibers (such as polyester fibers coated with a proprietary permanently wettable finish known as CELWET™) and long, high denier second group of synthetic fibers. Polyester fibers coated with CELWET are available from the Hoechst Celanese Corporation of Charlotte, North Carolina.

Such a blended core may also contain particles of hydrogel-forming polymer gelling agents to increase the absorptive capacity of the core.

In one preferred embodiment, the hydrogel-forming polymer gelling agents comprise "high-speed" absorbent gelling materials. The term "high-speed" absorbent gelling materials, as used herein, means those absorbent gelling materials that are capable of

absorbing exudates at such a rate that they reach at least about 40%, preferably at least about 50%, and most preferably at least about 90% of their capacity in less than or equal to about 10 seconds.

A suitable method for measuring the percent rate of capacity is described in Canadian Patent Applications Serial Nos. 2,098,322 and 2,098,502 filed respectively by Noel, et al. and Feist, et al on December 20, 1991. In alternative embodiments, it is also possible for the high-speed absorbent gelling materials to be mixed with other types (or ordinary speed) absorbent gelling materials.

Preferably, in the embodiment described immediately above, the high-speed absorbent gelling materials are in fibrous form. Fibrous superabsorbent materials (though not necessarily fibrous high-speed absorbent gelling materials) are discussed more fully in U.S. Patent 4,855,179, issued August 8, 1989, to Bourland, et al.

The term "fibrous absorbent gelling materials", as used herein, is intended to include absorbent gelling materials in the form of fibers that are comprised entirely of absorbent gelling material and bi-component fibers that are comprised at least partially of other materials which have their surfaces coated with absorbent gelling materials. A suitable fibrous high speed absorbent gelling material is known as FIBERSORB™ SA7000 formerly manufactured by Arco Chemical Company of Newton Square, Pennsylvania. Other suitable fibrous high speed superabsorbent fibers are the polyacrylate-based fibers known as FSA fiber Type 101, 102, 111, or 112 available from Courtauld's Fibers, Ltd.

The effective utilization of hydrogel-forming polymer gelling agents is believed to be improved in such a blended core. The use of higher concentrations of hydrogel-forming polymer gelling agents may also be possible.

45

The blended absorbent core 42 is preferably compressed to a density of at least about 1.5 g/cubic inch (about 0.09 g/cm³). The blended core 42 may be compressed to densities at least as high as about 4.0 g/cubic inch (about 0.25 g/cm³) to improve fluid wicking while still maintaining good softness and flexibility. (The density values specified above do not include the weight of any particles of absorbent gelling material.) Densification may be applied to the entire absorbent core 42 or only to selected portions. Patterned densification allows tailoring of the fluid handling properties to a specific need. For example, the density may be very low in the fluid target area to maximize fluid acquisition speed, and density may be very high near the core edges to maximize fluid wicking.

In one particularly preferred embodiment, the improved absorbent core 42 is an air-laid blend comprised of approximately 15% of 0.5 inch long, 15 denier per filament crimped polyester fibers and approximately 85% of cross-linked cellulose fibers compressed to a density of about 1 g/cubic inch (about 0.06 g/cm³).

The blended absorbent core 42 can be used as the entire core or it can be used as one or more layers in a layered construction. The blended absorbent core 42 can be used with or without an acquisition layer.

Figures 21-23 show an example of a core 42 in which layers of core material are used to produce a "profiled" sanitary napkin 20. The profiled sanitary napkin 20 is thicker in the center of the sanitary napkin and tapers so it becomes thinner toward the edges 22 and 24. Figures 22 and 23 show that such a profiled sanitary napkin 20 can be made by stacking layers having relatively large length and width dimensions on top of those with smaller length and widths (or vice versa).

In a layered construction, one or more layers can consist of all cellulose or cellulose/hydrogel-forming polymer material blends. The layers could also have differing fiber and/or

absorbent gelling material content or composition. For example, a higher percentage of absorbent gelling material could be provided in the lower layers to provide additional liquid storage capacity.

In other embodiments, elastic fibers may be included in the second group of fibers. Suitable elastic fibers include melt blown fibers, such as those included in the hydro-entangled melt blown fiber and cotton composite known as product #7102-102 available from Fiberweb, or fibers made of a polyethylene/Kraton blend, such as the material used to make Exxon film EXX-7.

(ii) Other Types of Cores.

Other core structures that provide extensible properties include unbonded nonwoven structures of synthetic fibers or various woven structures.

For instance, nonwoven structures including fibrous superabsorbent materials such as Fibersorb can be combined with various synthetic fibers to produce absorbent cores. These nonwoven structures can be made extensible by utilizing various patterns of bonding and fiber lay down.

The stretch properties of these nonwoven structures can be enhanced by any of the different methods described herein. Suitable methods for enhancing the extensibility of stretch include, but are not limited to ring rolling, including elastic fibers within the core, and including fibers that are crimped or curled that are capable of being extended (such as those shown in Figures 58 and 59) for extensibility.

One suitable structure comprises the aforementioned melt blown elastic fibers and cotton Fiberweb product #7102-102 with superabsorbent material. The superabsorbent material could be in either particulate or fibrous form. In other alternative embodiments, the structure could contain modified cross-linked cellulose fibers. The cross-linked cellulose fibers could be

added to the unbonded elastic fibers and superabsorbent material. In other embodiments, the cross-linked fibers could replace the elastic fibers (if the cross-linked fibers are intrinsically extensible), or the superabsorbent material.

(3) Providing the Core with Elasticity.

The absorbent core 42 may be made not only extensible, but elastically extensible in any of the embodiments described in this specification.

The absorbent core 42 may be made elastically extensible even though it has no elastic properties of its own. The absorbent core 42 can be made elastically extensible by attaching it to an elastic backsheet or topsheet so that the absorbent core 42 will extend and retract with the elastic topsheet or backsheet.

The sanitary napkin (or other absorbent article) 20 could also include any additional absorbent layers or other components such as are described in the patents incorporated by reference. For example, the absorbent article may comprise an acquisition layer or patch of cross-linked cellulose fibers positioned between the topsheet 38 and the absorbent core 42.

C. The Backsheet

(1) General Characteristics of Preferred Backsheet Materials.

The backsheet 40 is impervious to liquids and, thus, prevents body fluids from soiling the clothing of the user. A suitable backsheet 40 may be manufactured from a wide range of materials. Suitable materials include embossed or nonembossed polyethylene films and laminated tissue.

Suitable polyethylene film are manufactured by Monsanto Chemical Corporation and marketed in the trade as Film No. 8020,

48

by Clopay Corporation of Cincinnati, Ohio under the designation P18-0401, and by Tredegar Film Products of Terre Haute, Indiana under the designation XP-39385.

In one alternative embodiment of the sanitary napkin 20 (typically in which the topsheet 38 overlays only the main body portion 21 and does not extend out to form the top surface of the flaps, if any), the backsheet 40 may be comprised of two layers. In such a case, the backsheet 40 may comprise a first layer of lofted material disposed on the core-facing side 40A of the backsheet. The purpose of the first layer is to provide a comfortable, non-irritating surface against the body of the wearer.

The lofted layer may be comprised of any suitable material, such as a nonwoven material. Preferably, the lofted layer comprises a hydrophobic nonwoven material.

The second layer may be disposed on the garment side 40B of the backsheet 40, and may comprise a fluid impervious film. A low density polyethylene material about 0.01 to about 0.05 millimeters in thickness, preferably about 0.02 millimeters in thickness, has been found to work well as this second layer. A polyethylene film, such as is sold by the Ethyl Corporation, Visqueen Division, under model XP-39385 has been found particularly well suited for this second layer. The backsheet 40 may also be made of a soft, cloth-like material which is hydrophobic relative to the topsheet 38. A polyester or polyolefinic fiber backsheet 40 has been found to work well. A particularly preferred soft, cloth-like backsheet 40 material is a laminate of a polyester nonwoven material and a film such as described in U.S. Patent 4,476,180 issued to Wnuk on October 9, 1984.

(2) Providing the Backsheet With Extensibility.

There are many possible types of extensible backsheets. These include, but are not limited to the embodiments described below.

Generally, many of the techniques described above for providing the topsheet with extensibility may also be used to create an extensible backsheet 40. Thus, the backsheet materials can be made extensible by performing a mechanical operation, such as pleating, corrugating, or ring rolling the backsheet material. The backsheet 40 may be made extensible by forming it from a film made of a stretchable material such as Exxon film EXX-7 described above.

Typically, however, the films and the like used in constructing the backsheet 40 are unapertured, or if apertured, provided with open areas, or the like, are made liquid impervious by covering the open areas, closing the open areas, reducing the size of the open areas, or otherwise.

A particularly preferred extensible backsheet 40 is an extended adhesive film Formula #198-338 manufactured by the Findley Adhesives Company of Wauwatosa, Wisconsin. The Findley adhesive film is a fluid impervious film capable of extending 200 - 300%. It is preferred because it is also elastically extensible.

This film can be used "as is" in the sanitary napkin 20. One side of the adhesive film can be adhered to the garment-facing side 42b of the absorbent core 42. The other side will comprise the garment-facing side 40B of the backsheet 40, and may be used as a panty fastening adhesive.

Alternatively, the side of the adhesive film that forms the garment-facing side 40B may have its adhesive surface at least partially covered (or "blocked" to eliminate its adhesive characteristics). The adhesive body-facing side 40A of the backsheet can also be at least partially blocked.

The exposed adhesive can be blocked in a number of suitable ways. These include, but are not limited to attaching a layer of nonadhesive material to cover the exposed adhesive, and brushing

or sprinkling a powdered material such as talcum powder or corn starch on at least part of the exposed adhesive. The partial blocking of the exposed adhesive on the garment-facing side 40B of the backsheet 40 can be used with the remaining exposed adhesive to create particular panty fastening adhesive patterns.

In still other embodiments, an adhesive film can be created with one side that has adhesive tack, and one side without tack. One suitable adhesive film having these characteristics is a composite structure comprising a nonwoven elastomeric film with a low modulus pressure sensitive adhesive, such as adhesive film Formula #198-338 which is available with a blocking film such as film Formula H2301 from the Findlay Adhesives Company. Such materials are further described (and used for other purposes) in U.S. Patent 5,032,120 issued to Freeland, et al. on July 16, 1991, and U.S. Patent 5,037,416 issued to Allen, et al. on August 6, 1991.

In other preferred embodiments, the backsheet 40 can comprise an extensible laminate structure. Such a laminate can be comprised of two or more layers. The laminate can be comprised of layers each of which are capable of different extensibility. For instance, a backsheet 40 could comprise a laminate formed of a layer of Findley adhesive film that is covered on one or both sides by an extensible nonwoven web or by an extensible film.

D. Combinations of Topsheet, Backsheet, and Core Materials.

The sanitary napkin 20 of the present invention can be comprised of many different combinations of the topsheet, backsheet, and core materials described herein.

As noted above, the sanitary napkin 20 may be comprised of all extensible components. The sanitary napkin 20 shown in Figures 1-3 could, for instance, comprise a topsheet, backsheet,

and absorbent core selected from any of those materials described above. The different types of topsheet, backsheet, and absorbent core materials could be assembled in any of many possible combinations.

Alternatively, as noted above, the sanitary napkin 20 may be comprised of some extensible components and some inextensible components. The sanitary napkin could, for instance, be comprised of at least one of the extensible components described herein combined with any conventional inextensible materials, or with at least some of the basic materials described above prior to providing these materials with extensibility to form many different structures. This can be done to achieve some desirable performance characteristic, or to reduce the overall cost of the sanitary napkin 20.

Figures 23A - 23C show some non-limiting examples of sanitary napkins formed with some extensible and some inextensible components. Many other examples exist, as well, and are within the scope of the present invention.

Figures 23A and 23B show a sanitary napkin 20 having an extensible topsheet 38 and backsheet 40 and an inextensible absorbent core 42. The absorbent core 42 is suspended relative to the topsheet 38 and backsheet 40 by extensible strips or bands of material 101. The extensible strips 101 are secured to the topsheet 38 and the backsheet 40.

The absorbent core 42 in such an embodiment, thus, forms a sling-like structure positioned between the topsheet 38 and backsheet 40, and the topsheet 38 and backsheet 40 form an extensible bag-like structure around the absorbent core 42.

The sanitary napkin 20 shown in FIGS. 23A and 23B (especially the backsheet 40 of the same) can, thus, extend with the wearer's panties for fit and comfort. The inextensibility of the core 42 is advantageous in that it allows the capillary characteristics of the absorbent core 42 to be maintained even when the topsheet 38 and backsheet 40 are extended.

Figure 23C shows a sanitary napkin 20 having an extensible backsheet 40 that is combined with an inextensible topsheet 38 and an inextensible absorbent core 42. The sanitary napkin 20 shown in Figure 23C provides a similar advantage to the sanitary napkin shown in the preceding figure. The sanitary napkin 20 in Figure 23C, however, also provides several additional advantages.

The inextensibility of the topsheet 38 also allows the topsheet 38 to maintain its capillary characteristics (which often forms a composite absorbent system with the absorbent core 42) when the backsheet is extended.

The sanitary napkin 20 shown in Figure 23C also allows the components that are intended to be near the wearer's body (the topsheet 38 and core 42) to fit adjacent the wearer's body without stretching. The backsheet 40 which needs to adjust to the stretching of the wearer's panties, can do so.

The sanitary napkin 20 shown in FIG. 23C also has a pair of longitudinally oriented extensible strips 99 along the body-facing side of the sanitary napkin. The strips 99 can comprise a nonwoven material, or some other suitable material. The strips 99 are preferably soft to provide a more comfortable surface for the wearer. The strips 99 also connect the topsheet 38 to the backsheet 40. The strips 99 may, thus, serve as "isolation elements" (described below) which permit the backsheet 40 to extend and stretch more independently of the topsheet 38 and absorbent core 42 than if such strips were not present.

Several other alternative sanitary napkin embodiments having some extensible components and some inextensible components are those which have stretch attachment means for fastening to the wearer's panties. These are described below in Section 4A(1).

In addition to combining various different topsheet, backsheet, and core materials, some of the materials specified

53
herein can be used to serve more than one function, or as more than one component in an absorbent article.

For instance, some of the foam materials described herein as being suitable for use as an absorbent core can serve the functions of a topsheet, an absorbent core, and a backsheet. This can be accomplished by applying an impervious coating to the garment-facing side of the foam material, or otherwise treating the garment-facing side of the foam material to render it liquid impervious. In another embodiment, the topsheet 38 may be eliminated, and the underlying layer can serve the function that the topsheet 38 generally serves.

In addition, some of the materials described herein as being suitable for use as one component, such as a topsheet (or as a backsheet or core), can be used as one or more of the other components. (That is, provided that material has, or is modified to have, the desired characteristics for the component.)

Further, the manners described herein of making one of the components (such as the topsheet, backsheet, or core) extensible can generally be used to make any of the other components extensible.

E. Assembly of the Topsheet, Backsheet, and Absorbent Core.

The components of the sanitary napkin described above (the topsheet, backsheet, and absorbent core) can be secured together in any suitable manner that allows the sanitary napkin 20 to extend.

In the preferred embodiment shown in Figure 1, the components of the sanitary napkin 20 are sized so that the edges of the topsheet 38 and backsheet 40 extend outward beyond the edges of the absorbent core 42. The backsheet 40 comprises a stretchable adhesive film. The core 42 is placed on top of the backsheet 40.

54

The topsheet 38 is then placed on top of the core 42. The portions of the edges of the topsheet 38 that extend outward beyond those of the core 38 are secured to those of the backsheet 40.

As shown in Figure 1, the topsheet 38 is also preferably secured to backsheet 40 along a first seam, such as seam 90. Seam 90 is preferably liquid impervious. The seam 90 can be formed by any means commonly used in the art for this purpose such as by gluing, crimping, or heat-sealing. The seam 90 is illustrated on the winged product shown in Figure 5 as extending completely around the periphery of the main body portion 21.

It has been found that such a construction adequately secures the components of the sanitary napkin without securing the faces of the adjacent components to each other. Although, as noted above, it is often preferred to secure some of the components at their faces, as well.

The above is a preferred embodiment for ease of construction. (Other means of uniting the various components can be used.)

For instance, the present invention also includes so-called "tube" products. In these products, a liquid pervious cover material (such as topsheet material) can be wrapped completely around the absorbent core and the backsheet, and then the components can be secured together. In alternative arrangements, the topsheet could be wrapped around the core, and the wrapped core could be placed on and secured to the backsheet.

F. Fasteners for Attaching the Sanitary Napkin to the Wearer's Panties.

(1) General Characteristics of Preferred Fasteners.

The garment side 40B of the backsheet 40 may include fasteners (or "means for attaching the sanitary napkin to the undergarment of the wearer" or "attaching means") 44.

Figure 3 generally shows the central pad fastener, such as central pad adhesive 44 which is adapted to secure the sanitary napkin 20 to the crotch region of an undergarment. The central pad fastener 44 secures the main body portion 21 in the crotch portion of a panty.

Figure 5 shows the flap fastener, such as flap adhesive 45. The flap adhesives 45 are used to assist in maintaining the flaps 52 in position after they are wrapped around the edges of the crotch portion of the panty as described below. The flap adhesive 45 is located on the outer surface of flap 52, adjacent the distal edges 53 of the flaps 52 (i.e., the end of the flaps 52 farthest away from the longitudinal centerline L of the sanitary napkin 20). The flaps 52 can be maintained in position by attaching the flaps 52 to the undergarment, or to the opposing flap.

The adhesive fasteners are respectively covered by removable cover strips or release liners, such as central pad release liner and flap release liner, both designated 50. The adhesives should be covered with release liners 50 to keep the adhesives from sticking to extraneous surfaces prior to use. Suitable release liners are described in U.S. Patent 4,917,697.

The fasteners have been initially described in terms of adhesives for simplicity of description. The types of fasteners are not limited to adhesives, however. Preferred fasteners include but are not limited to adhesive fastening means, such as pressure sensitive adhesives, mechanical fasteners and combinations of adhesives and mechanical fasteners. The preferred types of fasteners and configurations thereof are described in greater detail below.

(a) Adhesive Fasteners.

Pressure sensitive adhesives, if used, may be applied to the garment side 40B of the backsheet 40 in many different patterns or configurations.

The adhesive configurations may be used for a variety of purposes in thin, flexible sanitary napkins. International Patent Application Publication No. WO 92/04000 entitled "Shape and Adhesive Fastening Means for an Absorbent Article" published in the names of Papa, et al. on March 19, 1992

discloses configurations can be used to: (1) allow the sanitary napkin to conform to the body of the wearer; (2) reduce the tendency of the longitudinal edges of the sanitary napkin to roll over and bunch, and the tendency of the end edges to flip over and bring the panty adhesives in contact with the wearer's body and pubic hair.

The Papa, et al. patent application teaches that the overall width of the adhesive fasteners should be as close as possible to the width of the crotch region of the wearer's panties to reduce the tendency of the panty elastics to apply forces that flip back the longitudinal edges of the napkin. The Papa, et al. patent application also teaches that in at least some embodiments, there should be an area along the longitudinal centerline L of the sanitary napkin 20 where the backsheet 40 is unattached to the wearer's panties to allow this central portion of the backsheet 40 to separate from the panties and the sanitary napkin to deform into a W-shape in transverse cross-section similar to that shown in FIG. 69.

The Papa, et al. patent application teaches that the adhesive should be close to the end edges 24 of the sanitary napkin to reduce end flipping, but not too close. The adhesive should not be too close to the end edges 24 because the slightest amount of end flipping will cause the adhesive to come in contact with the wearer's body. The adhesive should preferably be no more than about 6 mm. from the end edges 24, and most preferably no more than about 6 mm. plus or minus about 3 mm.

The adhesive configurations in the present invention can be used to accomplish these same purposes, and to provide sanitary

napkins that adjust to the dynamic changes of the wearer's body and panties when the sanitary napkin is worn.

The adhesive configurations that can be used depends on whether extensible or inextensible adhesives are used. The portion of the sanitary napkin on which extensible adhesives are located will be extensible. Sanitary napkins containing inextensible adhesives will typically only be capable of extension between the inextensible adhesive patches. Therefore, if inextensible adhesives are used, they are preferably applied in intermittent patterns to permit the sanitary napkin to extend between adhesive patches.

The adhesive can be applied in many configurations, including, but not limited to the following: (1) a single zone or patch of adhesive; (2) two parallel longitudinally-oriented strips on opposite sides of the longitudinal centerline; (3) two inwardly-arcuate strips of adhesive; and (4) multiple patches of adhesive. The adhesive can be applied in continuous or intermittent patterns in the above configurations (and other configurations) if the adhesive is extensible. As indicated above, if the adhesive is not extensible, it is preferably applied in intermittent patterns, including but not limited to intermittent dots, intermittent strips, and the like.

Figure 3 shows one preferred adhesive configuration for use on the sanitary napkin of the present invention.

The adhesive configuration shown comprises six $3/4$ " x $3/4$ " (about 2 cm. x 2 cm.) square pieces and two $3/4$ " x 2.5" (about 2 cm. x 6.4 cm.) longitudinally-oriented rectangular pieces. One rectangular piece is positioned on each side of the longitudinal centerline L. The square pieces are placed in the end regions 28 and 30 of the sanitary napkin. The square pieces are placed so that in each end region, one piece is in each corner 27, and one is disposed along the longitudinal centerline.

58

The adhesive patches 44 can each be covered with a separate cover strip 50. However, the patches are preferably covered with a single release sheet. This allows for ease of manufacture and benefits the consumer who does not have to dispose of several small individual cover strips 50.

Figures 24-31 show some non-limiting examples of additional adhesive configurations.

Figure 24 shows an adhesive pattern that comprises two longitudinally-oriented inwardly-arcuate strips of extensible adhesive disposed along the longitudinal centerline L and two patches of adhesive near the end edges 24 of the sanitary napkin 20. The patches near the end edges 24 may either be extensible or inextensible.

This adhesive pattern is believed to enhance the extensibility of the center of the sanitary napkin. The patches of adhesive near the end edges provide points along the longitudinal centerline L where the sanitary napkin is secured to the panties. Thus, when the panties stretch, the portion of the sanitary napkin along the longitudinal centerline will also stretch.

Figure 25 shows an adhesive pattern that comprises three rectangular patches of inextensible adhesive. One patch is located in the central region 32 of the sanitary napkin, and the other two patches are located in the end regions 28 and 30 near the end edges 24. This adhesive configuration allows the regions of the sanitary napkin designated 92 between the inextensible adhesive patches to stretch.

Figure 26 shows an adhesive configuration that comprises ten spaced apart patches of inextensible adhesive. The patches are fairly evenly spaced with five along each longitudinal side edge 22 of the sanitary napkin 20. This configuration provides a relatively uniform extensibility along the entire length of the

sanitary napkin 20. It also permits the longitudinal central region 34 of the sanitary napkin to separate from the wearer's panties for improved body contact.

Figure 26A shows an adhesive configuration in the form of four rectangular strips on patches of adhesive 44. These patches are arranged so that the overall adhesive pattern resembles a letter "X" with the center of the "X" missing and each of the patches running in a direction from the intersection of the longitudinal and transverse centerlines, I, to one of the corners 27 of the sanitary napkin.

This adhesive pattern allows the central region 32 of the sanitary napkin 20 to separate even more completely from the wearer's panties for improved body contact. In addition, the central region 32 of the sanitary napkin 20 may also be lifted into close contact with the wearer's body as a result of the combination of the extensibility of the central region 32 and the affixation of the end regions 28 and 30 to the wearer's panties when the sanitary napkin 20 is stretched longitudinally.

Figure 27 shows an example of an adhesive configuration that uses two different adhesives. The adhesives have different extensibility characteristics. This type of configuration (using adhesives of at least two different extensibilities) can be used to cause the sanitary napkin 20 to assume different configurations when worn.

The adhesive pattern shown in Figure 27 comprises two longitudinally-oriented strips of adhesive 44' located along the longitudinal side edges 22 of the sanitary napkin 20, and a zone of adhesive 44'' that covers the remaining portion of the backsheet 40.

The longitudinally-oriented strips of adhesive 44' have a first relatively low modulus of elasticity. Thus, the longitudinally-oriented strips 44' will extend when under the

60

application of relatively small forces. The zone of adhesive 44'' covering the rest of the backsheet 40 has a second relatively high modulus of elasticity (which is higher than that of the longitudinally-oriented strips 44'). The zone of adhesive 44'' is, therefore, less extensible than the longitudinally-oriented strips 44'.

When the sanitary napkin 20 shown in Figure 27 is subjected to extending forces, the longitudinally-oriented strips of adhesive 44' will typically extend a greater distance than the zone of adhesive 44''. This will cause the portions of the sanitary napkin along the longitudinal edges 22 to stretch with the wearer's panties. The portions of the sanitary napkin along the longitudinal centerline, together with the attached portion of the wearer's panties, will lift up. The center portion will, thus, come into closer contact with the wearer's body.

In another alternative embodiment, the extensibility of the adhesive areas shown in Figure 27 could be reversed. The longitudinally-oriented strips of adhesive 44' could have the second relatively high modulus of elasticity, and the zone of adhesive 44'' could have the first relatively low modulus of elasticity. In such an embodiment, the zone of adhesive 44'' will extend a greater distance than the longitudinally-oriented strips 44'.

This will form the sanitary napkin 20 into a "boat configuration" or cup shown schematically in Figures 86 and 87. The boat configuration is characterized by the portions of the sanitary napkin along the longitudinal sides 22 raising above the level of the central portions of the sanitary napkin 20. Such a configuration may be useful in providing the sanitary napkin with containment properties.

The adhesive configuration in other embodiments can be used to enhance the extensibility of other selected regions of the sanitary napkin.

If the adhesives are extensible, they preferably extend approximately the same amounts as the sanitary napkin as set forth in Table 1.

Suitable extensible adhesives include extensible adhesives, per se, and extensible adhesive/backsheet combinations. Any extensible adhesives known in the art can be used. Suitable extensible adhesive/backsheet combinations include, but are not limited to non-extensible adhesive used on an extensible backsheet material known as 3 Sigma 2474 available from Anchor Continental, Inc., 3 Sigma Division, of Covington, Ohio; elastically stretchable adhesive films such as Findley adhesive 198-338, or an elastically stretchable adhesive film known as 3M XPO-0-014 available from the Minnesota Mining and Manufacturing Company of St. Paul, Minnesota; or spray adhesives such as 3M adhesive 1442 on a low modulus elastic film.

Suitable inextensible adhesives may be those adhesives specified as 0.6 mil pass available from Century Adhesive as product number A305-4, or from Anchor Continental, Inc., 3 Sigma Division, of Covington, Ohio. Suitable inextensible adhesive fasteners are described in greater detail in U.S. Patent 4,917,697.

(b) Mechanical Fasteners, Frictional Fasteners,
and the Like.

The fasteners used with all of the various embodiments of the present invention described herein are not limited to adhesive attachment means. Any type of fastener used in the art can be used for such purpose.

For example, the sanitary napkin 20 could be secured to the wearer's undergarment by conventional VELCRO™ hook material, or by the fasteners described in U.S. Patent 4,946,527 issued to Battrell on August 7, 1990, U.S. Patents 5,058,247 and 5,116,563 issued to Thomas, et al. on October 22, 1991 and May 26, 1992,

respectively, and EPO patent application publication No. 0 381 087 published August 8, 1990, or high coefficient of friction foams and other high coefficient of friction materials such as those described in U.S. Patent 4,166,464 issued to Korpman, U.S. Patent 4,834,739 issued to Linker, III, et al., and U.S. Patent 5,011,480 issued to Gossens, et al.

The stretching forces exerted on the garment surface 20B of the sanitary napkin 20 by the wearer's panties, moving in response to the wearer's body motions accounts for many of the problems that lead to adhesive fasteners becoming unattached from the wearer's panties. The use of mechanical fasteners on stretchable absorbent articles is believed to be particularly beneficial, due to their tendency to reduce the effect of these shearing forces. Mechanical fasteners that engage the fabric of the wearer's panties will move with the panties, reducing the problems caused by these shearing forces.

G. Optional Components of the Sanitary Napkin

The sanitary napkin 20 of the present invention may be provided with optional additional components. (If desired, these additional components may be provided with extensibility in any of the manners described herein.)

The sanitary napkin 20 of the present invention can be provided with one or more additional pervious or absorbent layers. The additional pervious or absorbent layers may be positioned between the absorbent core 42 and either the topsheet 38, the backsheet 40, or both. As shown in FIG. 6, an absorbent layer, such as wicking layer 46, is positioned between the topsheet 38 and the absorbent core 42. This wicking layer 46 may be referred to as a secondary topsheet, or "wipe acquisition sheet", or "acquisition layer".

In the embodiment shown in Figure 6, the acquisition layer 46 is a folded sheet of nonwoven material. It should be understood, however, that the acquisition layer 46 need not be a folded sheet.

63

The terms "layer" or "web", as used herein to describe the acquisition layer, include, but are not limited to single unfolded sheets, folded sheets, strips of material, loose or bonded fibers, multiple layers or laminates of material, or other combinations of such materials. The terms layers and webs are thus, not limited to single unfolded layers or sheets of material.

In Figure 6, the acquisition layer 46 is a "double" z-folded sheet. The sheet 46, is more specifically folded so that when the sanitary napkin is cut along the transverse centerline I, the left half of the folded sheet appears as a reverse "z" in cross section and the right half appears as a "z". The sheet 46 is preferably folded so that it has an upper portion 49 that appears as a rectangular strip in plan view. The upper portion 49 of the acquisition layer 46 is preferably about 227 mm long, and between about 25 and about 38 mm wide. The upper portion 49 preferably has a caliper of from about 0.5 mm up to about 4 mm (the higher end of this range creates thicker products). Such a folded arrangement is described in greater detail in PCT Patent Application Publication No. WO 92/07535 published in the name of Visscher, et al. on May 14, 1992.

Figure 7 is a simplified cross-sectional view similar to that of Figure 6, showing an alternative arrangement of the components of the sanitary napkin 20. In Figure 7, rather than being a separate layer that is located on top of the core 42, the acquisition layer 46 is an integral layer (or component) that comprises the top layer of a laminated absorbent core 42 structure.

The acquisition layer 46 serves to improve wicking of exudates over and into the absorbent core 42. There are several reasons why the improved wicking of exudates is important. The improved wicking provides a more even distribution of the exudates throughout the absorbent core.

64

The improved wicking also allows the sanitary napkin 20 of the present invention to be made relatively thin. The acquisition layer 46 is capable of dispersing exudates over a large surface area of the absorbent core 42. The acquisition layer 46 thus allows the sanitary napkin 20 to absorb relatively large amounts of exudates. Bulky prior art sanitary napkins relied on a high degree of vertical absorption at the point where exudates are initially deposited. Because the absorbent cores of these prior napkins were fairly thick, they could absorb a large volume of exudates while utilizing only a small degree of the surface area or lateral absorption capacity. The thin versions of the sanitary napkins 20 of the present invention may absorb relatively large amounts of exudates because the wicking disperses the exudates over a large surface area of the absorbent core 42 where the exudates can better and faster be vertically absorbed into the absorbent core 42.

The acquisition layer 46 may also be used to direct exudates toward the ends of the core 42D. Liquid exudates that are deposited on the core 42 will tend to be distributed radially outward from the place where they are deposited. Since the core 42 of the sanitary napkin 20 is relatively narrow in comparison to its length, liquid exudates will reach the longitudinal edges 42C of the core 42C much sooner than they will reach the ends 42D of the absorbent core. The acquisition layer 46 can be used to longitudinally wick and direct exudates toward the ends 42D of the core 42. This more effectively utilizes the capacity of the core, and reduces the possibility of leakage caused by exudates prematurely reaching the longitudinal edges 42C of the core.

The characteristics of the acquisition layer 46 are as follows. The acquisition layer 46 should be liquid permeable. The acquisition layer 46 is also preferably compliant, soft feeling, and non-irritating to the user's skin. It can be made from any materials that are capable of dispersing exudates in the preferred manner described above. The materials may also be capable of having the topsheet 38 fused to them. The acquisition

65

layer 46 is preferably provided with stretch properties. The acquisition layer 46 has a body-facing face (or side) 46A, and a garment-facing face 46B.

The acquisition layer 46 should be hydrophilic. The fibers or yarns 55 comprising the acquisition layer 46 may be inherently hydrophilic. Alternatively, they may be treated to render them hydrophilic. Suitable methods for rendering fibers hydrophilic include treating them with a surfactant. The fibers can be treated by spraying the material comprising the acquisition layer with a surfactant or immersing the material into the surfactant. A more detailed discussion of such a treatment and hydrophilicity is contained in U.S. Patents 4,988,344 and 4,988,345 issued to Reising, et al. and to Reising, respectively. The hydrophilicity of these fibers allows the acquisition layer 46 to draw liquid exudates through the topsheet 38 from below.

The acquisition layer 46 may be comprised of many of the same materials as the absorbent core. The acquisition layer 46 may be comprised of woven or nonwoven materials. These materials may be synthetic, or partially synthetic and partially natural materials. Suitable synthetic fibers include polyester, polypropylene, polyethylene, nylon, viscous rayon fibers, or cellulose acetate, with polyester fibers being preferred. Suitable natural fibers include cotton, cellulose, or other natural fibers. The acquisition layer 46 may also be at least partially comprised of cross-linked cellulose fibers, or as in the case of the preferred embodiments described in the Examples set forth below, capillary channel fibers.

The acquisition layer 46 can also be comprised of combinations of the above materials, such as blends of fibers similar to those described above for use in the blended absorbent core, or any equivalent material or combinations of materials.

The fibers or yarns 55 comprising the acquisition layer 46 may be of any length, from staple length to continuous filaments. The length of the fibers 55 is preferably between about 1 inch and

66

about 3 inches (between about 2.5 cm. and about 7.5 cm.), and most preferably is about 1.5 inches (about 3.8 cm.). The fibers 55 preferably have a denier per filament of between about 1 and about 3, most preferably about 1.5.

The fibers 55 of the acquisition layer 46 are preferably oriented primarily in a single direction. Typically, the acquisition layer 46 can be manufactured with its fibers oriented in the machine direction (MD). The acquisition layer 46 can be placed in the product with most of the fibers 55 oriented in either the longitudinal direction or the transverse direction. (That is, the fibers 55 are generally parallel to either the longitudinal or transverse centerlines L of the sanitary napkin 20).

The phrases "generally parallel" to one of the centerlines, as used herein, are intended to include fibers that angle away from the respective centerline. The fibers are considered to be generally parallel to the longitudinal centerline as long as they are oriented more in the longitudinal direction than the transverse direction.

The orientation of the fibers 55 in the acquisition layer 46 in the longitudinal direction may be used to cause liquid exudates deposited on the acquisition layer 46 to preferentially wick and be distributed toward the ends 42D of the absorbent core 42. If the fibers 55 in the acquisition layer are generally parallel to the longitudinal centerline L, however, some operation, such as rang rolling, generally must be performed on the acquisition layer 46 for the acquisition layer to be extensible in the longitudinal direction.

The acquisition layer 46 may be any suitable size. The acquisition layer 46 need not extend the full width of the absorbent core 42. The acquisition layer 46 could, for instance, be in the form of a strip positioned similarly to (and of a size similar to) the upper portion 49 of the z-folded sheet shown in Figures 5 and 6.

The acquisition layer 46, if nonwoven, can be made by a number of different processes. These include, but are not limited to the following in order of preference from least to most preferred: meltblown, spunbonded, carded, the latter including, in order of preference, thermally-bonded, air-through bonded, powder bonded, latex bonded, solvent bonded, or most preferably, spunlaced. The latter processes are more preferred because it is easier to orient the fibers in a single direction in such processes.

Suitable commercially available products for use as the acquisition layer 46 include a 70%/30% rayon/polyester fabric known as SONTARA. The SONTARA fabric is described in greater detail in U.S. Patents 4,950,264 and 5,009,653 issued to Osborn.

In a particularly preferred embodiment, the acquisition layer 46 comprises a spunlace nonwoven web comprised of permanently wettable fibers. Preferably, the acquisition layer 46 is a 30 g/yards² (35 g/m²) polyethylene terephthalate (or PET) spunlace nonwoven web. Spunlaced fabrics of this type are manufactured by the Veratec Company of Walpole, Massachusetts. The spunlace nonwoven web is formed in such a way that most of the fibers are oriented in a single direction.

The fibers of this particularly preferred acquisition layer 46 material are made of a PET resin and are coated with the permanently wettable CELWET finish. The term "permanently wettable", as used herein, refers to fibers that will sink in less than or equal to about 7 seconds when tested according to the ASTM D 1117-74 Basket Sink Method.

The CELWET finish is particularly preferred for use in sanitary napkins having a topsheet 38 comprising an apertured film or scrim with hydro-entangled nonwoven fibers such as that described in Canadian Patent Application Serial No. 2,124,798 filed

in the name of Cree, et al. on November 6, 1992, because fibers coated with it remain extremely hydrophilic after hydro-entangling processes, and therefore, wick blood very well.

In another particularly preferred embodiment, the acquisition layer 46 comprises a spunbonded polypropylene nonwoven CELESTRA fabric known as P-9 manufactured by the Fiberweb Group.

If desired, the sanitary napkin 20 may be additionally provided with flaps 52 that extend outwardly from each longitudinal edge 22 of the sanitary napkin 20. The flaps 52 may be in any suitable configuration. Suitable flaps 52 may, for example, be made in accordance with the teachings of U.S. Patents 4,589,876, issued May 20, 1986 to Van Tilburg and 4,687,478, issued August 18, 1987 to Van Tilburg, Canadian Patent Application Serial No. 2,079,537 entitled "Absorbent Article Having Flaps and Zones of Differential Extensibility" filed September 30, 1992 in the name of Lavash, et al., Canadian Patent Application Serial No. 2,079,557 entitled "Absorbent Article Having Inwardly-Folded Pleated Flaps" filed September 30, 1992 in the name of Niihara, et al., Canadian Patent Application Serial No. 2,028,288 entitled "Sanitary Napkin Having Laterally Extensible Means for Attachment to the Undergarment of the Wearer", filed October 23, 1990 in the name of Osborn, et al.

The following Examples further illustrate the practice of the present invention, particularly those sanitary napkins which utilize capillary channel fibers in the construction of the same. The following Examples, however, are not intended to limit the scope of the absorbent articles encompassed therein.

68a

EXAMPLE I

THICK PAD

A sanitary napkin article is hand-made using the following components. Reference is made to Figure 18 for the assembly of the product.

The topsheet 38 is made in accordance with U.S. Patent 4,463,045 and ring rolled to provide it with longitudinal extensibility.

The absorbent core 42 is a superabsorbent material laminate as described above which is slitted or partially slitted for longitudinal extensibility. Figure 18 shows an absorbent core 42 that is slit at the end regions 28 and 30, but not at the central region 32. The backsheet 40 is an extended adhesive film known as Formula #198-388 manufactured by the Findley Adhesives Company of Wauwatosa, Wisconsin.

The sanitary napkin 20 shown in Figure 18 also preferably comprises a layer of capillary channel fibers 150. The thick pad comprises a swatch 152 of capillary channel fibers. In the thin sanitary napkin described in Examples II and III below, the swatch 152 of fibers is eliminated, and the layer of capillary channel fibers may be gathered at the center into a tuft 154. The sanitary napkin 20 further comprises a creped BOUNTY™ paper towel layer 156 and polyethylene end guards 158.

Figure 18 shows one preferred adhesive configuration for use on this extensible sanitary napkin embodiment. The adhesive configuration shown comprises six 3/4" x 3/4" (about 2 cm. x 2 cm.) square pieces of adhesive 44 and two 3/4" x 2.5" (about 2 cm. x 6.4 cm.) longitudinally-oriented rectangular pieces 44. One rectangular piece is positioned on each side of the longitudinal centerline L. The square pieces are placed in the end regions 28 and 30 of the sanitary napkin 20. The square pieces are placed so that in each end region, one piece is in each corner 27, and one is disposed along the longitudinal centerline L.

The adhesive patches 44 can be extensible, inextensible, or some patches can be extensible and some inextensible.

The adhesive patches 44 can each be covered with a separate release liner or cover strip 50. However, the patches are

70

preferably covered with a single release sheet for ease of manufacture and so that the consumer does not have to dispose of several small individual cover strips 50. Any commercially available release liner can be used. In one preferred embodiment, the release liner could be replaced by a wrapper that provides both an individually packaged sanitary napkin and a container for disposing the sanitary napkin after use, such as is described in U.S. Patent 4,556,146 issued to Swanson, et al. on December 3, 1985.

The capillary channel fibers are preferably substantially curled. Suitable capillary channel fibers are those designated SW194 available from the Eastman Chemical Company. The SW194 fibers comprise a carded staple sliver which has been stuffer box crimped to 7.8 crimps per inch and have an H-shaped cross-section with a channel width of 37 microns, a channel depth of 48 microns, and a denier of approximately 22 dpf. The capillary channel fibers are preferably 6 in. long; 0.75 g. fibers are used.

In the making procedure, the ring rolled topsheet is cut to the desired size, a template (2" x 7" opening) is placed on the back side of the topsheet and sprayed with the Findley 4031 adhesive. The adhesive is applied in a spiral pattern (see Figure 18A).

The layer of capillary channel fibers SW194 is hand-pressed in the center of the glue sprayed area with the fibers running parallel to the long axis of the topsheet. The capillary channel fibers are preferably pressed into the center of the glued area so that they at least partially cover at least some apertures of the topsheet. The capillary channel fibers may also at least partially protrude into the apertures of the topsheet.

The capillary channel fibers SW173 are hand pressed as a swatch (with fibers parallel to the long axis of the article) in the center of the layer capillary channel SW194 fibers. This provides a Pre-Assembly of the topsheet and capillary channel fibers.

71

For convenience, the remainder of the procedure is carried out using a concave forming die. The Findley adhesive backsheet (polyethylene backsheet with adhesive coating and release paper) is placed in the form. The slitted superabsorbent (or absorbent gelling material, or "AGM") laminated core is placed over the backsheet, and the creped tissue (BOUNTY) is placed over the AGM core. The Pre-Assembly, prepared above, is placed over the creped tissue, as shown in Figure 18. With the Pre-Assembly over the creped tissue, the article's components are pulled snugly over the edges of the form, but not so tightly that the components begin to pull away from the form. Firm pressure is applied to adhere the edges with the adhesive on the backsheet.

The article is removed from the form and the ends are pressed in place using a roller. The release paper is peeled from the back of the backsheet. The end guard polyethylene strips are added and the strips of panty fastening adhesive are placed on the article. The outer surface of the topsheet is sprayed with 0.01 g of PEGOSPERSE surfactant available from Lonza, Inc., Williamsport, PA.

The specifications of the finished product are as follows.

| <u>Parameter</u> | <u>Specifications</u> |
|---|-----------------------|
| Pad weight (g) | 9.82 \pm 0.12 |
| Core weight (g) laminate only | 2.57 \pm 0.04 |
| Pad length (mm) | 226 \pm 1 |
| Core length (mm) | 197 \pm 1 |
| Pad width at center (mm) | 81 \pm 2 |
| Core width at center (mm) | 70 \pm 0 |
| Pad caliper (inches at 0.13 psi) | 0.611 \pm 0.02 |
| Core caliper (inches at 0.13 psi) | 0.058 \pm 0.003 |
| Seal length (mm) | 8 \pm 1 |
| <u>Components</u> | <u>Specifications</u> |
| Polyethylene ring rolled formed-film topsheet (according to U.S. Patent 4,463,045) | ca. 9" x 5" |

72

| | |
|---|--|
| Capillary channel fibers SW194 (Eastman) | 1.5 g |
| Capillary channel fibers SW173 (Eastman) | 0.5 g. |
| Findley extensible adhesive film backsheet (Formula #198-338) | 9" x 5" |
| Creped BOUNTY paper towel | Shaped* |
| Panty fastening adhesive | Six 3/4" x 3/4" pieces; two 3/4" x 2.5" pieces |
| Release paper | As needed |
| Surfactant (PEGOSPERSE) TM | 0.01 g |
| White poly for ends | 4" x 0.75" |
| Absorbent gelling material (AGM) slit core non-slit central area; total core wt. 2.6 g; contains 0.7 g polyacrylate AGM | 70 mm x 193 mm with 2-3/4" non-slit center area |
| Findley Adhesive-4031 | 0.05 g |

*See Figure 18(38) for shape. The shape is designed to provide anatomical fit.

EXAMPLE IITHIN PAD

Reference is made to Figure 18. The assembly of the thin pad is equivalent, except that CCF SW173 fibers are used in place of the layer of CCF SW194 fibers (150), and no swatch (152) of fibers is used.

Assembly of the product is as follows. Cut capillary channel fibers (CCF SW173) to 7 in. length; 0.75 g fibers used. Cut the ring-rolled topsheet to size. Place the template on the bottom side of the topsheet and apply Findley 4031 adhesive (spiral pattern). Hand-press CCF SW173 fibers in the center of the glued area with the fibers running substantially parallel to the long axis of the topsheet. Lay the Findley backsheet on flat surface. Place the slitted AGM laminate core on the Findley backsheet. Center the creped BOUNTY tissue (shaped similarly to the topsheet)

73

over the laminate core. Center the topsheet/capillary channel fiber Pre-Assembly over the creped tissue. Secure the Pre-Assembly and smooth at edges. Roll the edges to seal. Peel the release paper from the back of the pad. Tear and remove in 2 or 3 pieces, then place the poly on the ends of the article. Place the panty fastening device (PFA) on the pad. Spray the topsheet with 0.01 g. PEGOSPERSE surfactant.

The specifications of the finished product are as follows.

| <u>Parameter</u> | <u>Specifications</u> |
|--|---|
| Pad weight (g) | 8.50 \pm 0.18 |
| Core weight (g) laminate | 2.54 \pm 0.09 |
| Pad length (mm) | 232 \pm 4 |
| Core length (mm) laminate | 201 \pm 1 |
| Pad width at center (mm) | 85 \pm 1 |
| Core width at center (mm) | 65 \pm 1 |
| Pad caliper (in. at 0.13 psi) | 0.211 \pm 0.005 |
| Core caliper (in. at 0.13 psi) | 0.074 \pm 0.003 |
| | |
| <u>Components</u> | <u>Specifications</u> |
| Polyethylene formed-film topsheet (ring rolled; per U.S. Patent 4,463,045) | 9" x 5" |
| Capillary channel fibers SW173 (Eastman) | 0.75 g; 7" length |
| Findley extensible adhesive film backsheet (Formula #198-338) | -9" x 5" |
| Creped BOUNTY paper towel | Shaped* |
| PFA (panty fastening adhesive) | Six 3/4" x 3/4" pieces and two 3/4" x 2.5" pieces |
| Release paper | As needed |
| PEGOSPERSE | 0.01 g |
| White poly for ends | 4" x 3/4" |
| AGM slit core non-slit center; total core weight 2.5 g; contains 0.7 g AGM | 65 mm x 193 mm with 2 3/4" non-slit center |

74

Findley 4031 (adhesive)

0.05 g

*As in Example I.

As noted above, in one preferred mode of this stretchable sanitary napkin 20, the central portion of the layer 150 of capillary channel fibers can be gathered into a small "loop" or "tuft" 154. This loop or tuft 154 thus extends upward from the layer of capillary channel fibers to firmly contact the topsheet 38. Moreover, the loop or tuft 154 is positioned centrally in the overall article, such that it can provide rapid acquisition and transport of fluid into the remaining portion of the layer of capillary channel fibers, and thence into the fluid storage layer of the article.

Advantageously, such "loop" or "tuft" not only concentrates capillary channel fibers at the point where fluid impinges onto the article, but also orients the capillary channel fibers which comprise the loop or tuft substantially in the upward z-direction, thus enhancing fluid movement in the downward z-direction of the article. The following Example illustrates an absorbent article having a substantially central, z-directional tuft of capillary channel fibers.

EXAMPLE III

PAD WITH CENTRAL TUFT OF FIBERS

A layer of capillary channel fibers of the type disclosed herein (with a 6-inch length) is gathered in its center to provide a slightly raised oval "tuft" having the approximate dimensions: 2-3 inches x-direction (or longitudinal dimension); 1.5 inches y-direction (or lateral dimension) at widest point; and 5 mm-10 mm z-direction.

The tufted bundle of fibers can be held in its tufted configuration by any convenient means. Typically, the tuft is passed through a confining slit in a sheet of paper or hydrophilic

75

polymer. Using the procedures disclosed herein, the tufted bundle of fibers is assembled into an absorbent article with the tuft residing approximately at the center of the overlying topsheet, and with the tuft in close contact with the topsheet, as explained hereinabove.

In use as a sanitary napkin, the article is positioned (e.g., intralabially) to maximize fluid uptake by the tuft. In an alternate mode, the ends of the looped fibers in the tuft are cut to provide a fleece-like, z-directional bundle of open-ended capillary channel fibers. In still another embodiment, the layer of capillary channel fibers comprising the base of the tuft is positioned wholly or partly within the wet-laid or dry-laid absorbent core of the article, rather than atop the core. In this latter embodiment, a commercially-available layered laminate core comprising two outer tissue layers with an intermediate layer of absorbent gelling material (AGM) can be used. The capillary channels at the base of the tuft can be slipped into the internal, AGM-containing layer.

EXAMPLE IV

ULTRA-THIN PAD

Reference is made to Figure 18. The assembly of the ultra-thin pad is equivalent, except that no swatches of capillary channel fibers are used.

Assembly of the product is as follows. Cut the ring-rolled topsheet to size. Place the template on the bottom side of the topsheet and apply Findley 4031 adhesive (spiral pattern). Lay the Findley backsheet on flat surface. Place the slitted AGM laminate core on the Findley backsheet. Center the creped BOUNTY tissue (shaped similarly to the topsheet) over the laminate core. Place the topsheet over the creped tissue. Secure the components and smooth at edges. Roll the edges to seal. Peel the release paper from the back of the pad. Tear and remove in 2 or 3

76

pieces, then place the poly on the ends of the article. Place the panty fastening device (PFA) on the pad. Spray the topsheet with 0.01 g. PEGOSPERSE surfactant.

The specifications of the finished product are as follows.

| <u>Parameter</u> | <u>Specifications</u> |
|---|--|
| Pad weight (g) | 8.50 ± 0.18 |
| Core weight (g) laminate | 2.54 ± 0.09 |
| Pad length (mm) | 232 ± 4 |
| Core length (mm) laminate | 201 ± 1 |
| Pad width at center (mm) | 85 ± 1 |
| Core width at center (mm) | 65 ± 1 |
| Pad caliper (in. at 0.13 psi) | 0.11 ± 0.01 (2.9 mm) |
| Core caliper (in. at 0.13 psi) | 0.074 ± 0.003 |
| | |
| <u>Components</u> | <u>Specifications</u> |
| Polyethylene formed-film topsheet (ring rolled; per U.S. Patent 4,463,045) | 9" x 5" |
| Findley extensible adhesive film backsheet (Formula #198-338) | -9" x 5" |
| Creped BOUNTY paper towel | Shaped* |
| PFA (panty fastening adhesive) | Six 3/4" x 3/4" pieces and two 3/4" x 2.5" pieces |
| Release paper | As needed |
| PEGOSPERSE | 0.01 g |
| White poly for ends | 4" x 3/4" |
| AGM slit core non-slit center; total core weight 2.5 g; contains 0.7 g AGM | 65 mm x 193 mm with 2 3/4" non-slit center |
| Findley 4031 (adhesive) | 0.05 g |

*As in Example I.

4. Alternative Embodiments of the Present Invention.

There are, in addition, numerous alternative ways in which the components can be arranged to provide a sanitary napkin that is capable of stretching or extending. The following are some non-limiting examples of suitable arrangements for the sanitary napkin of the present invention.

A. Sanitary Napkins Having Stretchable Attachment Devices and Alternative Types of Fasteners.

(1) Stretchable Attachment Devices.

The sanitary napkin 20 shown in Figures 32-43 have extensible (or preferably, stretchable) attachment devices 100.

The stretchable attachment devices 100 comprise components that may be attached to a sanitary napkin 20 to provide an extensible (or stretchable) interactive connection between the sanitary napkin and the wearer's undergarments. The stretchable attachment device 100 is particularly useful in providing a generally inextensible sanitary napkin with the ability to adapt to the stretching of the wearer's undergarments. The stretchable attachment devices are also useful in providing the other benefits of extensibility described above.

The stretchable attachment devices 100 are advantageous in that they may extend the full length of the sanitary napkin, or more. This feature allows the stretchable attachment devices 100 to provide greater coverage of the crotch of the wearer's panties, and, thus, greater protection from soiling of the same.

The stretchable attachment devices 100 described herein are provided in at least three basic varieties.

These include: (a) a first variety in which an extensible component is connected to a less extensible component of the sanitary napkin by an "isolation layer"; (b) a second variety that

comprises extensible attachment elements that extend outward along the longitudinal edges of the sanitary napkin; and (c) a third variety in which the stretchable attachment devices comprise extensible patches that are provided with a fastener in the center, and are bonded at least partially around their perimeter to the backsheet of the sanitary napkin.

These basic types of stretchable attachment devices and the important parameters of the same are discussed in greater detail below. It should be understood that many other types of stretchable attachment devices are also possible, and fall within the scope of the present invention.

(a) First Variety

The first basic variety of stretchable attachment device is shown in Figs. 32-35.

The stretchable attachment device 100 comprises at least one sheet of extensible material 101 that is used in conjunction with an isolation element 102.

The sheet of extensible material 101 preferably comprises an oval-shaped sheet of material. The sheet of extensible material 101 may, however, be in many other suitable configurations. The sheet of extensible material 101 is preferably at least extensible in the longitudinal direction.

The sheet of extensible material 101 (or any of the other stretchable attachment devices described herein) can, however, be extensible only in the transverse direction, or extensible only in a direction between the longitudinal and transverse directions. Alternatively, the sheet of extensible material 101 can be provided with bi-directional, or multi-directional extensibility.

The sheet of extensible material 101 can be of any suitable size and shape. Preferably, the sheet of extensible material 101 is an oval-shaped or racetrack-shaped sheet that is larger in

dimensions than the sanitary napkin 20. Figure 32 shows that portions of the sheet of extensible material 101 extend laterally outward beyond portions of the longitudinal edges 22 of the sanitary napkin 20 in the central region 32 of the sanitary napkin 20.

The portions of the sheet of extensible material 101 that extend laterally outward beyond the longitudinal edges 22 of the sanitary napkin 20 in the central region 32 may provide flaps 52 that can be folded down around and attached to the underside of the wearer's panties.

However, it is not necessary to form such flaps. It is also not necessary that any such flaps be attached to the underside of the wearer's panties. In other embodiments, the flaps 52 can be fastened to the topside of the wearer's panties. The flaps 52 can be fastened to the wearer's panties by adhesives, hook material, or any of the types of fasteners described herein.

The sheet of extensible material 101 can be any suitable material. In one non-limiting example, the sheet of extensible material 101 comprises a laminate comprising a sheet of extensible film such as Findley Adhesive 198-338 secured between two longitudinally extensible nonwoven webs. In another embodiment, the sheet of extensible material 101 could comprise an adhesive film secured between ring rolled plastic film sheets such as those used for the backsheet.

The isolation element 102 connects the sheet of extensible material 101 to an inextensible component (or to a component that is less extensible than the sheet of extensible material 101). The isolation element 102 provides material with some extensibility and/or slack material between the extensible and inextensible (or less extensible) components.

The isolation element 102 can comprise any suitable type of component that allows the sheet of extensible material 101 to

extend more independently of the inextensible (or less extensible) components than if such an element were not present. The isolation element indirectly connects the sheet of extensible material 101 and one or more inextensible or less extensible components of the sanitary napkin. Thus, it can be said to "isolate", "disassociate", or "decouple" the extensibility of the sheet of extensible material 101 from the inextensible components of the sanitary napkin. (For simplicity of description, the inextensible or less extensible components may be referred to simply as "inextensible components" rather than as both types of components. For a discussion of one version of the concept of decoupling, see U.S. Patent 5,007,906 issued to Osborn, et al. on April 16, 1991.)

The isolation element 102 shown in Fig. 33 replaces the backsheet of the sanitary napkin 20. In other embodiments, the sanitary napkin 20 may have a conventional backsheet, and the isolation element 102 may comprise a separate component that is attached to the backsheet 40. The particular isolation element 102 shown in Fig. 33 comprises a nonwoven web that is extensible in the longitudinal direction.

The isolation element 102 may be liquid pervious if it is used in addition to a backsheet. The isolation element 102 is preferably liquid impervious if it replaces the backsheet. The isolation element 102 can be rendered liquid impervious in any known manner.

The sheet of extensible material 101 can be attached to the isolation element 102 by any suitable attachment mechanism. Suitable attachment mechanisms include, but are not limited to adhesives, and the like.

The sheet of extensible material 101 should preferably be attached to the isolation element 102 at certain discrete points. This is preferred over laminating the sheet of extensible material 101 to the isolation element 102. The pattern of attachment

81

affects the ability of the sheet of extensible material 101 to move independently of the remainder of the sanitary napkin. This in turn affects the ability of the sanitary napkin 20 to adapt to the stretching of the wearer's undergarments.

Fig. 32 shows one way the sheet of extensible material 101 may be attached to the isolation element 102. The attachment mechanism comprises a large zone of adhesive 104 disposed along a portion of the longitudinal centerline L, and smaller adhesive areas 106 in the corners 27 of the sanitary napkin 20. These adhesives can be extensible or inextensible.

The large zone of adhesive 104 can comprise adhesives in any suitable pattern. The large zone of adhesive 104 can comprise one or more strips, patches, spots, or lines of adhesive. These strips of adhesive (or the like) within the large zone 104 can be intermittent or continuous.

The large zone of adhesive 104 can range in size. The length of the large zone of adhesive 104 can range in size from a small patch along the transverse centerline T to nearly the length of the sanitary napkin. The large zone of adhesive in the embodiment shown is about 6 inches (about 15 cm.) long. The large zone of adhesive 104 can range from very narrow to fairly wide. The width of the large zone of adhesive 104 can be so small that it is just a thin line of adhesive disposed along the longitudinal centerline.

A key dimension to the properly functioning of the first variety of stretchable attachment devices is the dimension D_1 (shown in Figure 32). The dimension D_1 can be measured longitudinally or laterally, as shown in Fig. 32.

The dimension D_1 is the distance from the place where the isolation element 102 is bonded to the inextensible components of the sanitary napkin, point P, to the place where the isolation element 102 is bonded to the sheet of extensible material 101, point Q.

The dimension D_1 is important because it affects the amount that the extensibility properties of the sheet of extensible material 101 and the remainder of the sanitary napkin 20 can be decoupled.

The dimension D_1 required for a particular sanitary napkin depends on the relative extensibility of the materials comprising all of the relevant portions of the sanitary napkin. The portions of the sanitary napkin relevant to the dimension D_1 include, but are not limited to the inextensible components, the sheet of extensible material, and the isolation element 102.

For instance, if the isolation element 102 is extremely extensible, the isolation element 102 will not need a great D_1 dimension to create a sufficient amount of slack between the sheet of extensible material and the inextensible components.

The dimension D_1 will also depend on the dimensions of the attachment mechanism used to attach the sanitary napkin 20 to the wearer's panties. This is because the slack material can be present in the portion of the sheet of extensible material 101 between the edge of the panty fastener and the place where the sheet of extensible material 101 is joined to the isolation element 102.

Preferably, in the embodiment described herein, D_1 is greater than or equal to about 5 mm., more preferably greater than or equal to about 10 mm., more preferably, and most preferably is greater than or equal to about 15 mm. The upper limit on D_1 is as follows. D_1 is preferably not so large that point Q extends past the intersection of the centerlines of the sanitary napkin, point I, (although in less preferred embodiments, it may).

Figures 34 and 35 show what happens when the sanitary napkin 20 with this first variety of a stretchable attachment device 100 is stretched. The sheet of stretchable material 101 stretches

with the wearer's undergarments U. Figure 34 shows that the end regions 28 and 30 of the sanitary napkin 20 will curve upward when the sanitary napkin is viewed from the side. This will provide the sanitary napkin an overall curved longitudinal profile. Figure 35 shows that the sanitary napkin 20 is saddle-shaped when viewed from the end.

The particular curvature shown in FIGS. 34 and 35 results from the configuration of the attachment mechanism between the sheet of extensible material 101 and the isolation element 102. Other attachment mechanisms may be used to create other stretched configurations.

The stretchable attachment device 100 can have additional features.

For example, at least portions of the sheet of extensible material 101 could comprise a material having a low return force (or a "high set"). These are materials that, when stretched, will not tend to return to their unstretched dimensions. They will tend to remain (or set) close to their extended length.

These materials having a high set are particularly useful in some portions of the sanitary napkin. Two such portions are where the flaps 52, or other lateral side extensions of the sanitary napkin are folded around the curved leg openings in the crotch of a pair of panties. The flap material in these areas is stretched when the flaps 52 are folded around the crotch of the panties. The stretching puts tension on the flap material, especially where the crotch of the panties is wider. (The stresses on the flaps is described in greater detail in U.S. Patent 4,917,697 issued to Osborn, et al. on April 17, 1990.)

When the flaps 52 comprise a material having a high set, they will stretch to fit around the crotch of the wearer's panties. The flaps 52 will not tend to retract and bunch the wearer's panties, or come unattached from the underside of the panties.

(Ideally, flaps 52 comprising such materials will not even have to be attached to the underside of the panties to remain in place.

The flaps 52 formed on the sheet of extensible material 101 could comprise the portions that are made of such materials. In such a case, the entire sheet of extensible material 101, with the exception of the flaps 52, could comprise a laminate of a zero strain nonwoven, such as a ring rolled nonwoven material or a nonwoven web comprised of unbonded fibers, and a Findley extensible adhesive. The Findley adhesive could be omitted from the portions of such a laminate that form the flaps 52.

The sheet of extensible material 101 that has the extensible adhesive therein would be elastically extensible. The flaps 52, however, would not be elastically extensible. The flaps 52 could, as a result, be folded around and attached to the underside of the wearer's panties and would not tend to flip back.

In other embodiments, only portions of the flaps 52 could comprise such materials. For instance, the portions of the flaps 52 located on and near the axes where the flaps 52 are folded around the panty crotch may be comprised of such materials, while the remaining portions of the flaps 52 are not because the former portions are subjected to greater stresses when the flaps are folded.

In other embodiments, the entire sheet of extensible material 101 could comprise such materials.

In other embodiments (shown schematically in Figure 35A), a sheet comprised of a relatively inextensible material could be provided with flaps 52 comprising such materials. Thus, these materials are separately useful on embodiments without stretchable attachment devices.

In a preferred embodiment, as shown in Fig. 35A, the flaps 52 are provided with strips of hook material or other mechanical

85

fastener material. In this preferred embodiment, the strips of hook material are distributed in a radial pattern. The hooks can be oriented in a particular direction for improved gripping properties. Preferably, in the embodiment in Fig. 35A, the mouths of the hooks are oriented so that they face the intersection of the longitudinal and transverse centerlines.

In still other embodiments, such materials can be used on a sanitary napkin 20 having otherwise conventional flaps.

(b) Second Variety

The second basic type of stretchable attachment device is shown in Figs. 36-41A.

Figure 36 is a simplified schematic perspective view of a sanitary napkin 20 having a stretchable attachment device 100 that comprises a pair of extensible (preferably stretchable) attachment elements 108. (The sanitary napkin is shown without any fasteners on the stretchable attachment elements in Fig. 36. The sanitary napkin is shown in dotted lines in Fig. 38.)

The stretchable attachment device 100 shown in the figures comprises a separate component that is attached to the sanitary napkin 20. The stretchable attachment device 100 comprises one unitary structure. The stretchable attachment device 100 is unitary in that the pair of stretchable attachment elements 108 are connected to each other by an optional central portion 109. The central portion 109 may be extensible, but need not be.

Many other constructions are possible. For example, in other embodiments, the central portion 109 can be omitted, and the stretchable attachment elements 108 may each be attached to the sanitary napkin.

86

In the embodiment shown in FIG. 38, however, the stretchable attachment device 100 is joined to the garment side 20B of the sanitary napkin 20 by a joining device, such as the central portion attachment elements 117. The central portion attachment elements 117 can comprise any suitable extensible or inextensible attachment device. The central portion attachment elements 117 can be discrete attachment devices. Preferably, however, the central portion attachment elements cover most or all of the central portion 109.

The sanitary napkin 20 is shown in FIGS. 36-38 as having approximately the same dimensions as the central portion 109 of the stretchable attachment device 100. In other embodiments, the dimensions of the sanitary napkin 20 can be less than, or greater than those of the central portion 109.

In alternative embodiments, the stretchable attachment elements 108 may be integral parts of the components of the sanitary napkin, such as the topsheet, backsheet or absorbent core. For instance, the stretchable attachment elements 108 may be extensions of the longitudinal edges of the topsheet 38 and/or the backsheet 40.

The attachment elements 108 extend outward from the longitudinal side edges 21C of the main body portion 21 of the sanitary napkin 20. The stretchable attachment elements 108 are either bonded to the underside of the central portion 109 of the stretchable attachment device 100, or to the garment-facing side 20B of the sanitary napkin near the middle of the sanitary napkin 20. The ends 111 of the stretchable attachment elements 108 are free.

The stretchable attachment elements 108 are preferably in the form of two strips or flanges of material. The outside longitudinal edges 110 of the stretchable attachment elements 108 are preferably symmetrically opposite, and convex inwardly oriented (i.e., curved inward toward the longitudinal centerline).

87

The stretchable attachment elements 108 may be thought of as being "butterfly shaped". The outside longitudinal edges 110 of the attachment elements 108 preferably correspond closely to the shape of the panty crotch. The stretchable attachment elements 108, however, can be in many other suitable configurations.

The stretchable attachment elements 108 shown in FIGS. 36-38 are folded inward under the main body portion 21 at a first fold axis F_1 that runs along the longitudinal edges 21C of the main body portion 21. The stretchable attachment elements 108 are folded back outward near the longitudinal centerline at a second, preferably curved, fold axis F_2 . If the stretchable attachment device is not provided with a central portion, the stretchable attachment elements 108 should be joined along the longitudinal edges 21C of the main body portion 21.

Figure 38 is a schematic cross-sectional view of the sanitary napkin 20 in Figure 37 taken along line 38-38. The stretchable attachment elements 108 are folded so that when the sanitary napkin 20 is cut along the transverse centerline, the left half of the stretchable attachment device 100 appears as a reverse "z" in cross-section and the right half appears as a "z". The diagonal portion of the "z" structure, and the part of the stretchable attachment device forming the lower portion of the "z" are preferably both extensible.

The stretchable attachment elements 108 are preferably attached to the backsheet 40 of the sanitary napkin in the area of the intersection of the longitudinal and transverse centerlines L and T. This stabilizes the attachment elements. The attachment elements 108 can be attached by any suitable attachment element retainer 118. Suitable retainers include adhesives.

Figure 38 shows some of the dimensions of one preferred sanitary napkin having attachment elements 108. The width of the main body portion 21 of the sanitary napkin W_U as measured at the narrowest portion (i.e., along the transverse centerline) is about

88

2.5 inches (about 6.4 cm.). The lateral distance designated "A" between the first fold line F_1 and the second fold line F_2 is about 1 inch (about 2.5 cm.). The lateral distance designated "B" between the second fold line F_2 and the outside edge 110 of the attachment elements is about $1 \frac{3}{8}$ inches (about 3.5 cm.).

The attachment elements 108 may be attached to the inside surface of the crotch region of the wearer's panties. The attachment elements 108 need not be folded down under the panty and attached to the underside of the panties. The attachment elements 108, thus, differ from conventional sanitary napkin wings. In other embodiments, however, the attachment elements 108 may be folded down and attached to the underside of the wearer's panties.

The stretchable attachment elements 108 are adhered to the crotch of the wearer's panties by attachment element fasteners, such as discrete patches of adhesive 120. The adhesive patches 120 may be extensible or inextensible in such an embodiment. In alternative embodiments, as shown in Figure 39, rather than being in the form of patches, the adhesive 120 may be in the form of a continuous strip of stretchable adhesive. The adhesive 120 can, however, be arranged in any suitable configuration.

In other alternative embodiments, one or more of the other types of fasteners described above (i.e., mechanical or frictional fasteners) may be used as attachment element fasteners 120. These fasteners may be used alone, or in conjunction with adhesive fasteners.

One key dimension to the proper functioning of this embodiment is the dimension D_2 . The dimension D_2 is the distance from the place where the stretchable attachment elements 108 are bonded to the backsheet 40, point R, to the nearest portion of the attachment element fasteners 120, point S. The dimension D_2 affects the amount that the extensibility properties of the stretchable attachment elements 108 and the remainder of the sanitary napkin 20 can be decoupled.

There are often other key dimensions as well. These depend on how the stretchable attachment device 100 is constructed.

The attachment elements 108 can be made extensible in a number of different ways. The attachment elements can be: (1) comprised entirely of an extensible material; (2) comprised of an inextensible material that is gathered and has an extensible material, such as elastic strands, attached thereto; (3) comprised of a material having inextensible zones and extensible zones; and (4) comprised of a folded inextensible material that defines folded sections with extensible elements that bridge the folded sections.

Several of these ways of providing extensibility are described in greater detail below with reference to the drawing figures. The manners of making the attachment elements are, however, not limited to those described herein.

Figures 36-39 show attachment elements 108 that are made extensible in the first manner described above. The attachment elements 108 shown in Figures 36-39 may be comprised entirely of stretch materials. In this case, the attachment elements 108 need not be provided with optional elastic strands 116.

Figures 36-39 can also be used to illustrate attachment elements 108 that are made extensible in the second manner described above. In this case, the attachment elements 108 shown in Figures 36-39 could comprise an inextensible material, such as extensions 114 of the polyethylene backsheet that are provided with optional elastic strands 116.

In the second alternative embodiment (shown in Figures 36-39), the elastic strands 116 are stretched and attached to the attachment elements 108. The elastic strands 116 gather the attachment elements 108 longitudinally inward (when the stretching forces are removed from the elastic strands 116). This leaves the

90

attachment elements 108 elastically extensible in the longitudinal direction. The elastic strands also preferably gather the stretchable attachment elements 108 into a curved configuration that corresponds to the shape of the panty crotch.

The elastic strands 116 are preferably located in the central region 32 of the sanitary napkin. In one preferred embodiment, the elastic strands 116 are about 3 inches (about 7.5 cm.) long prior to stretching and are about 4 inches (about 10 cm.) long when stretched.

Figure 40 is a schematic plan view of a sanitary napkin 20 having an alternative type of stretchable attachment elements 108. The stretchable attachment elements 108 shown on Figure 40 are provided with a plurality of elastic strands 116 and a continuous strip of stretchable adhesive 120.

Figure 41 shows attachment elements 108 made extensible in the third manner described above. The attachment elements 108 shown in FIG. 41 comprise extensible zones of material 117 and inextensible zones of material 119.

Figure 41A shows attachment elements 108 made extensible in the fourth manner described above. Figure 41A shows a sanitary napkin 20 having stretchable attachment elements 108 comprising a folded inextensible material 114.

The folded inextensible material 114 is preferably in the form of strips or lateral extensions of one or more components of the sanitary napkin. The attachment elements 108 are provided with extensible elements, such as stretch elements 126 that bridge the folded sections of the inextensible material 114.

The inextensible material 114 in the sanitary napkin embodiment shown in Figure 41A is folded at several fold lines 122. The inextensible material 114 is folded so that portions of the inextensible material 114 overlap in the central region 32 of

the sanitary napkin. These form overlapping sections 124 of the inextensible material 114. The overlapping sections 124 are not limited to the central region 32 of the sanitary napkin. The overlapping sections 124 may also extend into the end regions 28 and 30 of the sanitary napkin 20, as well.

The stretch elements 126 that bridge the folded sections of the inextensible material 114 can comprise one or more elastic strands, a patch of elastic material, or the like. The stretch elements 126 are attached to the inextensible material 114. The stretch elements 126 in Figure 41A are attached to the inextensible material 114 by a plurality of stretch element attachment elements, designated 128.

The stretch element attachment elements 128 secure the stretch elements 126 to the separate folded portions of the inextensible material 114 designated 130, 132, 134. This allows the folded portions of the inextensible material 114 (especially the folded portions designated 130 and 134) to move longitudinally with respect to each other when the inextensible material 114 are subjected to stretching forces.

(c) Third Variety

The third basic type of stretchable attachment device is shown in FIGS. 42 and 43.

The third type of stretchable attachment device 100 comprises one or more extensible zones (or patches) of material which have a panty fastener positioned at or near their center. The zones of extensible material are bonded at least partially around their perimeter to the sanitary napkin.

For instance, the third type of stretchable attachment device 100 could comprise a single patch of extensible material. The patch of extensible material could be about the size of the backsheet 40 of the sanitary napkin 20. It could have a panty

fastener positioned in its center. This patch of extensible material could be joined about at least a portion of its periphery to the periphery of the backsheet 40. This stretchable attachment device 100 will be capable of stretching between where it is fastened to the wearer's panties and the places where it is joined to the backsheet 40.

Figure 42 is a schematic plan view of the garment surface 20B of a sanitary napkin 20 having stretchable attachment elements 108 in the form of three zones of extensible (and, preferably stretchable) material 136.

The zones of stretchable material 136 shown in Figure 42 can comprise any of the types of extensible (or stretchable) materials described herein, such as an extensible or stretchable film or extensible or stretchable laminate.

The zones of stretchable material 136 are permanently attached to the backsheet 40 by zone attachment elements 138. The zone attachment elements 138 bond the perimeters of the zones of stretchable material 136 to the backsheet 40. Suitable zone attachment elements 138 include, but are not limited to extensible and inextensible adhesives.

The sanitary napkin 20 is affixed to the inside of the wearer's panties. The sanitary napkin 20 is affixed to the panties by zone panty fasteners (or simply "zone fasteners") 140. The zone panty fasteners 140 are located on the zones of stretchable material 136. The zone panty fasteners 140 may comprise any of the types of fasteners described herein, including, but not limited to, extensible and inextensible adhesives, and mechanical fasteners and frictional fasteners.

The sanitary napkin 20 shown in Figure 42 is provided with extensibility in the following manner. The sanitary napkin 20 components, such as the topsheet, backsheet, and absorbent core, may, but need not, be provided with extensibility. When the

93

sanitary napkin 20 is secured in the wearer's panties by zone panty fasteners 140, the zones of stretchable material 136 can stretch and separate from the backsheet 40 of the sanitary napkin 20. The zones of stretchable material 136 will separate from the backsheet 40 at their center where they are not peripherally bonded to the backsheet 40 by the zone attachment elements 138. This provides an attachment device with some extensible slack material that can move in response to movements of the wearer's undergarments.

A key dimension to the proper functioning of this embodiment is the dimension D_3 . The dimension D_3 is the distance from one of the places where the zones of stretchable material 138 are bonded at their perimeter to the backsheet 40, point N, to the nearest point on the zone panty fasteners 140, point O.

The distance D_3 is a measurement of the amount of extensible material between the place where the zones of stretchable material 136 are fixed to the inextensible components and the place where the zone panty fasteners 140 will be affixed to the wearer's panties.

Figure 43 is a schematic plan view of the garment surface 20B of a variation of the sanitary napkin 20 shown in FIG. 42. The sanitary napkin 20 shown in FIG. 43 has zones of stretchable material 136 in the form of butterfly-shaped strips.

The sanitary napkin 20 without the zones of stretchable material 136 shown in Figure 43 has butterfly shaped extensions from the longitudinal sides 21C of its main body portion 21.

The zones of stretchable material 136, shown in Figure 43 are peripherally attached to the sanitary napkin 20. The zones of stretchable material 136 are attached to portions of the backsheet 40 that comprises part of the main body portion 21. The zones of stretchable material 136 are also peripherally attached to

94

portions of the backsheet 40 that form the butterfly shaped extensions of the longitudinal sides 21C of the main body portion 21.

The zones of stretchable material 136, shown in Figure 43 are preferably provided with zone panty fasteners 140 that comprise curved strips of extensible adhesive.

The embodiments shown in Figures 32-43 are just a few of the many possible stretchable attachment device configurations that fall within the scope of the present invention.

The present invention, however, is not limited to stretchable attachment devices, per se. The types of structures described above can be used in other portions of absorbent articles. For instance, the structures described above can also be used to provide a stretchable or extensible connection between any inextensible (or less extensible) components of an absorbent article and extensible components of the same.

For example, instead of providing a stretchable connection between an inextensible sanitary napkin and the wearer's panties, similar stretchable elements could be used to provide a stretchable connection between an extensible backsheet and an inextensible topsheet and absorbent core.

In other alternative embodiments, a sanitary napkin could have an extensible adhesive that supplies the remainder of the sanitary napkin with extensibility or stretchability.

B. Sanitary Napkins Having Mechanical Attachment Devices.

Figure 44-46 are schematic bottom plan views which show alternative sanitary napkin 20 embodiments having mechanical attachment devices 142.

The sanitary napkins shown in FIGS. 44-46 may also use adhesive fasteners. These adhesives may be extensible or inextensible as in the preceding sections. The key difference in the alternative sanitary napkins 20 shown in FIGS. 44-46 is that they employ at least some mechanical attachment devices 142.

The mechanical attachment devices (or elements) 142 in these embodiments may comprise any of the types of mechanical fasteners (or frictional fasteners) described herein. The mechanical attachment devices 142 preferably comprise patches of hook material.

The mechanical fastening devices 142 preferably have engaging elements 148 which may be hook-shaped. Only a few of the engaging elements 148 are shown in the drawings for simplicity. The fastening devices 142, however, need not have hook-shaped engaging elements. The engaging elements 148 may be in any suitable configuration.

The engaging elements 148 engage the fabric (typically, the yarns of a knit or woven fabric) covering the panty leg elastics. The mechanical fastening devices 142 may engage the fabric covering the top of the wearer's panty elastics, the fabric covering the sides of the panty elastics, or the fabric covering the bottom of the panty elastics.

The patches of hook material are positioned at key points on the sanitary napkin 20. The patches of hook material are preferably positioned at or near the panty elastics when the sanitary napkin 20 is placed in the wearer's panties.

The patches of hook material in all of the embodiments described in this specification may be placed on any other portions of the sanitary napkin. The patches of hook material, for instance, can be placed on the main body portion 21 near the edges 24 of the sanitary napkin 20.

The use of mechanical attachment elements 142 at or near the panty elastics and after the end edges 24 of the sanitary napkin 20 eliminates several problems associated with the use of adhesive fasteners alone. Mechanical fasteners are not subject to the problem of adhesives sticking to the wearer's body hair. They are also not subject to the problem of the adhesives become unattached and causing the sanitary napkin folding back and sticking to itself when the panty and panty elastics move and stretch.

Positioning mechanical attachment elements 142 near the panty elastics can also be used advantageously. This is shown in Figure 44A.

Figure 44A is a representation of a sanitary napkin 20 in place in the wearer's panties. The leg elastics of the wearer's panties, E, are stretched when the panties are put on by the wearer. This causes the elastics to exert forces F_E against the wearer's body. These forces provide a normal force component relative to the portions of the flaps 52 that are against the wearer's body.

The normal force component can be used to cause mechanical or frictional attachment means to be more effective. Normal forces may aid mechanical fasteners having hook-like elements in penetrating and hooking onto the fabric of the wearer's panties. Ideally, the normal forces will cause the hooks to automatically engage the panty fabric with little or no effort needed on the part of the wearer to press the hooks into the panties.

The normal forces may also aid mechanical and frictional fasteners that utilize frictional forces for attachment or are aided by frictional forces. Some mechanical and frictional fasteners have rough (e.g., sandpaper-like) surfaces. Such fasteners act by providing mechanisms that tend to resist sliding between the sanitary napkin and the wearer's panties. The normal forces exerted by the panty elastics will increase the resistance to sliding along the surface of the panties at the leg elastics.

The above-described mechanical attachment devices 142 may be used on many different types of sanitary napkins described herein.

Preferably, the mechanical attachment devices 142 are used on sanitary napkins comprised of all extensible components.

For example, the mechanical attachment devices 142 can be used with relatively inextensible sanitary napkins having one of the stretch attachment devices described above. This will provide a stretchable attachment structure that moves with the panty and panty elastics.

Most preferably, the mechanical attachment devices 142, per se, associated with any of these sanitary napkins are extensible (and preferably stretchable) and flexible. The mechanical attachment devices 142 can be made extensible in any suitable manner.

For instance, the mechanical attachment devices 142 could be made extensible by affixing them to an extensible element, such as an element similar to the zones of stretchable material 136 used in the stretchable attachment devices described above.

Alternatively, the mechanical fastening devices 142 can be made extensible by constructing them from extensible component materials. For example, the mechanical attachment devices 142 could comprise a patch of hook material that has an extensible backing and hooks protruding from the extensible backing.

The extensible mechanical fastening devices 142 in such embodiments will be better able to move with the panty elastics. This is a departure from known fasteners such as adhesives. Adhesive fasteners are typically capable of only being subjected to and reacting to the forces exerted on the sanitary napkin by the wearer's panty elastics. Adhesive fasteners typically react to these forces in undesirable manners, such as by becoming detached from the wearer's panties.

The mechanical attachment devices 142 may also be used in combination with adhesive fasteners, such as those designated 144, to provide different fastening characteristics. Figures 44-48 show a non-limiting number of alternative embodiments which use some mechanical fasteners with adhesive fasteners.

The adhesive fasteners 144 are preferably positioned inboard of the periphery of the sanitary napkin in such embodiments. The mechanical fasteners 144 can then be positioned outboard of the adhesive fasteners 142. This avoids the aforementioned problems of the fasteners sticking to themselves or to the wearer's body associated with the use of adhesive fasteners.

Figure 44 shows a sanitary napkin 20 embodiment which is provided with side extensions 146. The side extensions 146 have mechanical attachment devices 142 located thereon. An adhesive fastener 144 runs down the center of the sanitary napkin 20. The side extensions 146 are rectangular in Figure 44. However, they may be of any suitable shape.

The side extensions 146 shown in Figure 44 need only extend far enough laterally outward that they are able to overlies the elastics wearer's panties. The side extensions 146, preferably, however, extend far enough laterally outward that they can be wrapped around the wearer's panty elastics. The mechanical attachment devices 142 ideally will be able to secure the sanitary napkin 20 in place much better than conventional sanitary napkin flaps having adhesives alone. Thus, the side extensions 146 may, but need not, extend laterally outward to the same extent as conventional sanitary napkin flaps.

The mechanical fastening devices 142 may be distributed over any portion of the main body portion 21 of the sanitary napkin, or the side extensions 146. The only limitation on the minimum size of the mechanical attachment devices 142 is that the mechanical fastening devices 142 provide sufficient holding capability so they will remain securely fastened to the the wearer's panties.

As noted above, the mechanical fastening devices 142 are particularly useful when located in the area of the wearer's panty elastics. Thus, at least some portions of the mechanical attachment devices 142 should be spaced laterally outward from the longitudinal centerline L to the places where the sanitary napkin contacts the portions of the panties containing the panty elastics.

An example panty crotch could range in width from about 1.5 inches (about 3.8 cm.) or less to about 4 inches (about 10 cm.). Preferably, therefore, the spacing of at least a portion of the mechanical fastening devices 142 from the longitudinal centerline L is greater than or equal to about .75 inches (about 2 cm.) to the edge of the panty crotch (and beyond) for the panties having narrower crotches.

With panties having greater widths, at least a portion of the mechanical fasteners are preferably spaced greater than or equal to about 1 inch (about 2.5 cm.), more preferably greater than or equal to about 1.25 inches (about 3 cm.), more preferably greater than or equal to about 1.5 inches (about 4 cm.), more preferably greater than or equal to about 1.75 inches (about 4.5 cm.), up to greater than or equal to about 2 inches (about 5 cm.) to the edge of the panty crotch and beyond.

(When it is said that the mechanical fasteners extend from a certain point to the edge of the panty crotch and beyond, this means that at least a portion of the fasteners must start inboard of the edge of the panty crotch. The inside edges of the mechanical fasteners, thus, are preferably arranged so that they will engage the top surface of the panty in the crotch region. Mechanical fasteners having inside edges that are positioned so far outboard of the longitudinal centerline that they are only capable of fastening to the underside of the wearer's panties are less preferred.)

100

Figure 45 shows a sanitary napkin 20 embodiment which is provided with side flaps 52. The sanitary napkin 20 has a longitudinally-oriented adhesive fastener 144 on its main body portion 21. The side flaps 52 have mechanical fastening devices disposed in two patches 142. The patches are positioned to engage the wearer's panties at the leg elastics when the side flaps 52 are wrapped around the wearer's panties. The flaps 52 also have conventional adhesive fasteners 144 located near the distal ends 53 of the flaps 52. The adhesive fasteners 144 are used to attach the flaps 52 to the underside of the wearer's panties.

Figure 46 shows a sanitary napkin 20 embodiment that has a narrow central region 32 and wider end regions 28 and 30. The longitudinal edges 22 of the sanitary napkin 20 are shown as being formed by linear segments. The shape of the sanitary napkin 20 preferably generally corresponds to the shape of the crotch region of the wearer's panties. In other alternative embodiments, the longitudinal edges 22 of the sanitary napkin 20 are curved.

The sanitary napkin 20 shown in Figure 46 has a longitudinally-oriented adhesive fastener 144 on its main body portion 21. A strip of mechanical fastener material 142 runs along each longitudinal edge 22 of the sanitary napkin 20. The longitudinal edges 22 can be fastened to the inside surface of the wearer's panties. In alternative embodiments, the longitudinal edges 22 can extend laterally outward a greater distance so they may wrap around and be attached to the underside of the wearer's panties.

Figures 47 and 48 are a schematic top plan view and a schematic cross-sectional view of a sanitary napkin 20 having stretchable attachment elements 108 similar to those shown in Figure 39. The sanitary napkin 20 shown in Figures 47 and 48 is provided with mechanical attachment devices 142 (preferably in the form of strips) along each outside edge 110 of the attachment elements 108, and adhesive fasteners 144 (also in the form of strips) along the inside edges of the strips comprising the mechanical attachment devices 142.

101

Figure 49 is a schematic top plan view of a sanitary napkin 20 similar to that shown in the preceding two drawing figures. The sanitary napkin 20 shown in Figure 49 differs in that the strips comprising the adhesive fasteners 144 are replaced by additional mechanical attachment devices 142.

C. Sanitary Napkins With Pull-Out Tabs.

Figures 50-54 show a sanitary napkin 20 having a pull-out tab that allows the sanitary napkin to be adjusted in length by the wearer.

The adjustable length sanitary napkin 20 shown allows the wearer to individually adjust the length of the sanitary napkin to her specific body/panty size and activity.

Women in the past have had to adjust the position of the sanitary napkin by moving the sanitary napkins forward or backward in an attempt to cover areas of their panties susceptible to staining. However, when a woman moved the sanitary napkin backward in her panty, the front portion of the panty became exposed, and vice versa.

Alternatively, women could select sanitary napkins of varying length. This approach suffered from the disadvantage that it required the woman to have multiple sizes of sanitary napkins depending on her activity. These different sized sanitary napkins still could not be adjusted to the woman's specific needs/size. Furthermore, to be fully protected, the woman would need to carry more than one size of product with her to meet her changing needs throughout the day.

Several patents disclose attempts to make extendable absorbent articles. These include U.S. Patent 3,653,382 issued to Easley, et al. on April 4, 1972, U.S. Patent 3,848,599 issued to Schaar on November 19, 1974, U.S. Patent 4,596,570 issued to

102

Jackson, et al. on June 24, 1986, and U.S. Patent 4,597,759 issued to Johnson on July 1, 1986. The search for more convenient ways of making absorbent articles, particularly sanitary napkins, extensible has continued, however.

FIGS. 50-54 show sanitary napkins made adjustable by providing pull-out tabs. The pull-out tab 160 provides a mechanism that may be pulled on by the wearer to lengthen the sanitary napkin 20. There are a non-limiting number of ways to provide a pull-out tab feature. FIGS. 50-53 and FIG. 54, respectively, show two alternative sanitary napkin 20 embodiments which have pull-out tabs 160.

The sanitary napkins 20 shown in FIGS. 50-54 comprise the basic components described above (i.e., the topsheet 38, backsheet 40, and absorbent core 42). The components of the sanitary napkin 20, however, need not be extensible. They may be extensible, inextensible, or, some of the components may be extensible and some inextensible.

The topsheet 38 preferably comprises either a ring rolled apertured film, a low basis weight nonwoven material with fibers oriented in the transverse direction, a hydro-entangled nonwoven material, or an apertured film made of an extensible material such as Exxon film EXX-7 or an extensible scrim hydro-entangled with polypropylene or capillary channel fibers.

The absorbent core 42 is preferably thin and flexible, or made from core materials that, while not extremely thin, are flexible and can be easily compressed. It is understood that thick cores can also be used, however.

Suitable thin and flexible core materials comprise the superabsorbent material laminate known as WATER-LOCK L-535, and absorbent tissue cores such as those made from BOUNTY tissue described above. Other suitable thin and flexible core materials comprise a double layer acrylic fibrous material known as Lanseal

103

F available from the Choli Company, Ltd., of Higashi, Osaka, mixtures of superabsorbent fibers such as those known as FIBERSORB entangled with other types of fibers, and included in the hydro-entangled melt blown fiber and cotton composite known as product #7102-102 available from Fiberweb.

Suitable core materials that can be easily compressed are the composite absorbent structures described in the aforementioned U.S. Patents 4,773,903 and 4,865,596. Other suitable core materials that can be compressed to yield a thin core include airfelt and superabsorbent material cores (in the form of blends, laminates, etc.) which have a caliper of less than or equal to about 0.1 inch (about 2.5 mm.).

Suitable backsheet materials could be any of those described above, including, but not limited to Findley adhesive film #198-338 (with a thickness of 5 mil); 1 mil polyethylene film; 1 mil polyethylene blend with Krayton or ethylene vinyl acetate; Exxon film EXX-7 or Tredegar X-7644 film. One preferred backsheet material shown in Figures 50-54 is the laminate of a polyester nonwoven material and a film described in U.S. Patent 4,476,180 issued to Wnuk on October 9, 1984. This material should be made extensible by ring rolling, or by any other suitable process.

The sanitary napkin 20 is preferably provided with a liquid impervious interliner 48 positioned between the absorbent core 42 and the backsheet 40. The interliner 48 is associated with the undergarment-facing side 42B of the absorbent core 42. The interliner 48 serves as a first constraint for any bodily discharges that may tend to migrate toward the backsheet 40.

The sanitary napkin 20 is preferably constructed so that the absorbent core 42 is joined indirectly to the backsheet 40 along the longitudinal edges 42 of the core 42. The term "indirectly joined" means that the absorbent core 42 is joined to another component, which is in turn joined to the backsheet (in the manner specified). This other component is preferably within the topsheet 38 or the interliner 48.

The absorbent core 42 is preferably also joined to the backsheet 40 along at least one transverse juncture 25. The transverse juncture 25 is optional, however.

The remainder of the absorbent core 42, including at least the rear end edge 42D', is unattached to the backsheet 40. The unattached portion of the core 42 may move apart and separate from the backsheet 40.

The transverse juncture 25, if present, can be a region such as a line or an edge. FIGS. 50-52 show an embodiment in which the transverse juncture 25 may be generally coincident with an end edge 24, such as the front end edge 24A of the sanitary napkin 20. The end edge 24 at which the transverse juncture 25 is located may be referred to as the "joined end edge" (or "joined transverse edge"). The other end edge 24B is referred to as the "unattached end edge".

The sanitary napkin 20 may be constructed generally in accordance with U.S. Patent 5,007,906 entitled "Decoupled Sanitary Napkin" which issued to Thomas W. Osborn, et al. on April 16, 1991, only with the pull-out tab 160 described herein.

Typically, the transverse juncture 25 will be located in the portion of the sanitary napkin designated 161 that is to the front of the wearer when the sanitary napkin 20 is worn. Typically, the unattached end edge 24B is oriented towards the rear of the wearer when the sanitary napkin 20 is worn.

In other embodiments, the transverse juncture 25 need not be at an end edge 24 of the sanitary napkin 20. The transverse juncture 25 can be located between the end edges 24A and 24B of the sanitary napkin 20. In such cases, the sanitary napkin 20 may have two unattached end edges.

105

The transverse juncture 25, as shown in Figure 52, functions like a hinge. The transverse juncture 25 allows parts of the sanitary napkin 20 (e.g., the topsheet 38, the core 42, and the interliner 48) to articulate with respect to the backsheet 40 about the joined end edge 24A. The sanitary napkin 20 articulates between a closed position and an open position (the latter being shown in Figure 52). In the "closed position", the unattached end edges of the core 42 and backsheet 40, 42D' and 40D', are generally proximate and preferably adjacent. In the "open position" of FIG. 52, the unattached end edges of the core and backsheet, 42D' and 40D', are separated in the Z-direction, relative to each other, from their respective closed position locations.

The pull-out tab 160 is preferably provided in the rear portion 162 of the sanitary napkin 20. The pull-out tab 160 comprises an extendable portion designated 164, and an attachment portion (or attachment element) 166. The latter attaches the extendable portion 164 to the rest of the sanitary napkin 20.

The tab 160, as shown in Figures 51 and 52, is preferably positioned between the interliner 48 and the backsheet 40. The tab 160 can, however, be located in a recess between any of the components at the rear portion 162 (or front portion 161) of the sanitary napkin 20.

The length of the tab 160 is preferably between about 1 inch (about 2.5 cm.) and about 6 inches (about 15 cm.), although it may be longer or shorter. The tab 160 is preferably capable of lengthening the sanitary napkin 20 from 110% or 115% to 300% of its original length. Lengthening the sanitary napkin 20 optimally occurs at forces of less than 2 pounds.

FIG. 52 shows that the extendable portion 164 of the pull-out tab 160 preferably comprises several components including: (1) a topsheet portion 168, (2) an absorbent core portion 170, (3) a backsheet portion 172, and (4) a fastener 174.

106

The components of the extendable portion 164 can be comprised of identical materials as the respective topsheet 38, core 42, backsheet 40, and fastener 44 of the sanitary napkin. Alternatively, the components of the extendable portion 164 can comprise any other materials described herein as being suitable for use as a topsheet, absorbent core, backsheet, and fastener, respectively. The extendable portion 164, may, but need not, be comprised of extensible components, however.

In still other alternatives, the components of the extensible portion 164 can comprise combinations of the types of materials described herein as being suitable for use as a topsheet, absorbent core, and backsheet. For instance, the topsheet portion 168 and absorbent core portion 170 may, for instance, be unitary in construction. The topsheet portion 168 and absorbent core portion 170 may, for example, comprise a flannel material that provides a soft surface for contacting the wearer's body and a degree of absorbency so it can serve as an extension of the absorbent core 42.

The attachment portion 166 of the pull-out tab 160 serves two primary purposes. The attachment portion 166 permits the extendable portion 164 to be pulled out by the user. The attachment portion 166, however, must be capable of preventing the extendable portion 164 from pulling completely out of the sanitary napkin, and from over-extending.

The attachment portion 166 can comprise any suitable type of element capable of serving these purposes. The attachment portion can be integral with the extendable portion 164, or with some other portion of the sanitary napkin, or it may be a separate element attached to the extendable portion 164.

The attachment portion 166 can, for instance, be a rectangular piece of polyolefinic material. Figure 52 shows an embodiment in which one end, 166', of the attachment portion 166 is attached to the front end 164D' of the extendable portion 164.

107

The other end 166'' of the attachment portion 166 is attached to the core-facing side 40A of the backsheet 40. The attachment portion 166 must be flexible enough to permit the extendable portion 164 to extend to the position shown in Figure 53 from the position shown in Figure 52.

The attachment portion 166, in a preferred embodiment, may comprise elastically extensible materials so that the tab 160 will retract if the user over-extends the pull-out tab 160.

To pull out the tab 160, the user lifts or decouples the rear portion 162 of the sanitary napkin 20, and pulls on the rear edge 164D'' of the extendable portion 164.

The rear edge 164D'' of the extendable portion 164 may optionally be provided with a grip tab for the user to hold when pulling out the extendable portion 164.

As best shown in FIG. 52, the sanitary napkin 20 may also have a means for controlling the separation of the absorbent core 42 from the backsheet 40. The means for controlling the separation of the core 42 from the backsheet 40 prevents the sanitary napkin 20 from unintended gross deformations and from exceeding the intended open position. As used herein, the means for controlling the separation of the core from the backsheet refers to any component which limits the Z-direction separation of the core 42 from the backsheet 40.

Figure 52 shows one suitable means for controlling the amount of separation of the core 42 from the backsheet 40 which comprises a material having a longitudinally-oriented pleat (a "pleated material") 176 to join the core 42 directly or indirectly to the backsheet 40. The pleated material 176 is provided with longitudinally oriented fold lines 178. Alternative means for controlling the separation of the core 42 from the backsheet 40 are described in greater detail in U.S. Patent 5,007,906.

108

FIG. 54 is a sectional view similar to that of Figure 51 of a sanitary napkin 20 which has an alternative type of pull-out tab 160 that slides out instead of folding out. This particular tab 160 (or at least a part thereof) is positioned inside a tab guide such as sheet of material 180. Figure 54 shows an embodiment in which the tab 160 is wrapped in the sheet of material 180. The sheet of material 180 serves as a sleeve which guides the tab 160 and ensures that it is pulled out straight.

The tab 160 does not have to be completely wrapped by the tab guide 180. For example, the tab guide could be C-shaped, and only the longitudinal side edges of the tab need be wrapped by the tab guide 180.

In embodiments which utilize a tab guide, the tab 160 also preferably still has some type of attachment portion. The attachment portion is generally still needed so the tab 160 will not pull completely out of the sanitary napkin.

D. Adjustable Length Sanitary Napkins

FIG. 55 and 56 show still other alternative sanitary napkin embodiments which may be extended.

The sanitary napkin embodiments shown in Figures 55 and 56 need not be extended by the user, however. They may also be extended by stretching forces exerted on the sanitary napkin in use.

Figure 55 shows a sanitary napkin 20 having a segmented and overlapping core 42 (or "split core"). The sanitary napkin 20 has a core 42 which comprises two segments, first and second segments, 42' and 42''. The segments are arranged so that the second segment 42'' partially overlaps the first. The opposite arrangement is also possible, however.

Figure 56 shows a core 42 which comprises three segments, a first, second, and third segment, 42', 42'', and 42''' in which the second segment bridges the first and third segments.

110

The topsheet 38 of the sanitary napkin 20 shown in Figure 58 can be made extensible by any suitable manner described above. The backsheet 40 can also be made extensible by any manner described above. The topsheet 38 and backsheet 40 are shown as being made extensible by providing them with corrugations, or by pleating the same.

The size of pleats in the backsheet 40 of the sanitary napkin 20 shown in Figure 58 may be larger than those in the topsheet 38 (or vice versa). The size of pleats in the backsheet 40 preferably ranges from about 0.05 inches (about 1 mm.) to greater than or equal to about 0.15 inch (about 4 mm.).

Figure 59 is a schematic depiction of how the fibers 182 in the absorbent core 42 of the sanitary napkin 20 shown in Figure 58 might extend. The left side of Figure 59 shows the fibers 182 in an unextended condition. The right side of Figure 59 shows the fibers 182 in an extended condition.

Figure 60 shows an embodiment in which the sanitary napkin 20 has a corrugated absorbent core 42. The sanitary napkin 20 has a topsheet 38 and backsheet 40 that are made extensible by providing them with fine corrugations. The topsheet 38 and backsheet 40, however, can be made extensible by any suitable manner described above.

Figure 61 is a schematic depiction of the how the absorbent core 42 of the sanitary napkin 20 shown in Figure 60 might extend. The left side of Figure 61 shows the absorbent core 42 in an unextended condition. The right side of Figure 61 shows the absorbent core 42 in an extended condition.

There are numerous other types of extensible or adjustable length sanitary napkins. Any suitable combinations of the foregoing ways of making the sanitary napkin extensible are also suitable.

The sanitary napkins 20 shown in Figures 55 and 56 have an extensible topsheet 38 and an extensible backsheet 40. The topsheet 38 may be any of the extensible topsheet materials described herein. The backsheet 40 may be any of the extensible backsheet materials described herein.

The core 42 may comprise any of the core materials described herein. The material comprising the segments of the core may, but need not, be extensible since the segments are capable of moving relative to each other.

The segments of the core 42 are shown as being unconnected. In alternative embodiments, they could overlap, but be connected by an isthmus connection, or by some other type of connection described in Canadian Patent Application Serial No. 2,097,336 entitled "Sanitary Napkin Having Transversely Segmented Core" filed in the name of Osborn on December 10, 1991. In still other embodiments, the segments of the core 42 could be joined indirectly through some other component of the sanitary napkin.

Figure 58 shows still another alternative extensible sanitary napkin embodiment.

The sanitary napkin 29 shown in Figure 58 has an absorbent core 42 comprised of an extensible layer of entangled fibers. The sanitary napkin 20 preferably has an extensible topsheet 38 and an extensible backsheet 40.

The embodiment shown in Figure 58 can, however, be comprised of less than all extensible components (or components that extend the same amounts). Further, all of the components need not be associated together as an extensible unit. For example, only the topsheet and core, the core and backsheet, or the topsheet and backsheet may be associated as extensible units. (The same applies to any of the other sanitary napkin embodiments described in this specification.)

E. Sanitary Napkin Having a Cinch.

FIGS. 62-66 show an alternative embodiment of the sanitary napkin of the present invention that has device or means for placing the sanitary napkin in contact with the wearer's body, such as a cinch 190.

The cinch 190 is a component that may be used to improve contact between the absorbent portion of the sanitary napkin and the wearer's body. The cinch 190 may be pulled upward against the body by the wearer and attached to the panty. The cinch 190 may be considered to be a component part of the sanitary napkin 20, or as a separate element that is attached to the sanitary napkin 20.

The cinch 190 is particularly useful in placing a portion of the topsheet 38 and absorbent core 42 in contact with the crevice between the wearer's buttocks (the "gluteal groove") and the crevice in the wearer's perinium (the "perineal groove"). This allows the sanitary napkin 20 to intercept menses near the vaginal introitus and along the surfaces of the perineal and gluteal grooves.

It has been found that leakage of menses from the crevice between the wearer's buttocks (i.e., the gluteal groove) is a major source of product failure. That is, menses tend to run out of the back of the sanitary napkin. This is particularly true during night time use of sanitary napkins. This often results in soiling of the wearer's garments and bedding.

The cinch 190 is believed to provide the sanitary napkin with improved performance by tending to reduce leakage at the rear of the sanitary napkin 20. The cinch 190 is also believed to provide additional benefits that are presently found only with tampons. These include reduction in the feel of menstrual flow, improved body cleanliness, and reduction in odor. The cinch 190 also provides the user with the opportunity to adjust the sanitary napkin 20 to her own individual needs and comfort preferences.

112

The sanitary napkin 20 shown in FIGS. 62-64 having the cinch 190 also comprises the same basic components described above. The sanitary napkin 20 may also be constructed generally in accordance with U.S. Patent 5,007,906 entitled "Decoupled Sanitary Napkin" issued to Thomas W. Osborn, et al. on April 16, 1991, only with the cinch described herein. The cinch 190 can be thought of as replacing the interliner 48.

As in the case of the alternative embodiments described in the preceding section, the various components of the sanitary napkin 20 need not all be extensible. They may be extensible, inextensible, or some of the components may be extensible and some inextensible.

Figure 62 shows that the sanitary napkin with the cinch has a plan view shape that resembles the shape of a spoon. This is primarily due to the shape of the cinch 190 (described below). The configuration of the cinch 190 shown in the drawings, however, is only one preferred embodiment. The cinch 190 may be in many other suitable shapes.

The sanitary napkin 20 that is provided with the cinch 190 of the present invention may be of any suitable shape. The sanitary napkin 20 can comprise any of the sanitary napkins shown in this specification, or in the documents incorporated by reference herein. The sanitary napkin 20 may be provided with flaps 52, or not. The sanitary napkin 20 can be relatively thick or thin.

The cinch 190 is believed to function best, however, when used on thin, flexible sanitary napkins. This is because the cinch 190 will be able to better conform thin, flexible sanitary napkins to the shape of the wearer's body. The cinch 190, however, can also work well with soft, thick, deformable sanitary napkins, such as those described in U.S. Patents 4,773,903 and 4,865,596 issued to Weisman, et al.

113

The cinch 190 has a number of component parts. In the embodiment shown in the drawings, the cinch 190 has a front portion 192 that resembles the bowl of a spoon, and a narrower rear portion 194 that resembles the handle of a spoon. The cinch 190 has a body-facing side 190A and a garment-facing side 190B. The sanitary napkin 20 is provided with panty fasteners 44 for fastening the backsheet 40 of the sanitary napkin 20 to the crotch of the wearer's panties. The cinch is also provided with a cinch fastener 196. The cinch fastener 196 is used to attach the rear portion 194 of the cinch 190 to the rear panel of the wearer's panties.

The construction of the sanitary napkin 20 is shown schematically in Figure 63. The topsheet 38 and absorbent core 42 are preferably joined to the backsheet 40 at a juncture (preferably a transverse juncture) 25. The juncture 25 functions like a hinge, allowing parts of the sanitary napkin 20 (e.g., the topsheet 38, the core 42, and the cinch 190) to articulate with respect to the backsheet 40 about the joined end edge 24A.

(These parts may be referred to as "absorbent parts" because they preferably contain some absorbent component, even though the topsheet 38, per se, may not be absorbent.) The topsheet 38 and absorbent core 42 may be joined to the backsheet 40 directly, or indirectly, such as by being joined to the cinch 190 which is in turn joined to the backsheet 40.

The cinch 190 may be attached to several different components of the sanitary napkin. For instance, the cinch 190 may be attached to either face of the topsheet 38, to the body-facing surface 42A of the absorbent core 42, the garment-facing surface 42B of the absorbent core 42, or the body-facing side 40A of the backsheet 40. The cinch 190 should preferably be liquid pervious if it is attached to the topsheet 38 or to the body facing surface 42A of the absorbent core 42.

The cinch 190 is preferably attached to the other components at the juncture 25 so that the absorbent parts of the sanitary napkin articulate about a point located in the front 1/2 of the sanitary napkin, preferably in the front 1/3 of the sanitary napkin 20. This allows the absorbent parts of the sanitary napkin to decouple from the wearer's panties sufficiently to fit into the wearer's perineal and gluteal grooves.

This is shown specifically in Fig. 65. Figure 65 shows the sanitary napkin 20 having a cinch 190 in place in a pair of panties, U. The portion of the wearer's body shown is designated with reference letter B. The portions of the body shown include the mons region, M; the vaginal introitus, V; the anus, AN; and the crevice between the buttocks or gluteal groove, G.

The body of the wearer may be divided into three anatomically distinctly-shaped regions when the wearer is viewed along the longitudinal axis. From the front of the wearer's body to the back of the wearer's body, the first of the three regions is the mons region M. The mons region M has a compound curved convex upward shape. The second region is that containing the vaginal introitus. The second region is defined by the labia majora and resembles a W-shaped outline. The third region is determined by the gluteal groove and is generally cusp-shaped and defined by two convex upward and outwardly diverging lines. The characteristics of these parts of the body are described in greater detail in the aforementioned Canadian Patent Application Serial No. 2,097,336.

Figure 65 shows that the cinch 190 preferably articulates about a point such as the transverse junction 25 that is anterior (in front of) the wearer's anus when the device is worn. Even more preferably, this point is also anterior the wearer's vaginal introitus.

The absorbent parts of the sanitary napkin 20 can also be joined to the cinch 190 at other points. For instance, Figure 36 shows that the composite of the topsheet/absorbent core 38, 42

115

provide a structure which could also be attached to the cinch 190 along virtually the entire length of the composite 38, 42.

In other alternative embodiments, the backsheet 40 can be omitted, provided the garment-facing side 190B of the cinch 190 is liquid impervious. In such cases, the cinch 190 may be provided with a fastener such as those designated 44, and the cinch 190 may be attached directly to the wearer's panties. The fasteners 44 in such an embodiment should be positioned so that the sanitary napkin 20 is able to articulate as described herein.

Figures 63 and 64 show that the front portion 192 of the cinch 190 may raise parts of the sanitary napkin above the backsheet 40 when the sanitary napkin 20 is worn. The front portion 192 of the cinch 190 can, thus, support the sanitary napkin in close contact with the wearer's body. The parts of the sanitary napkin in contact with the wearer's body preferably contain at least some absorbent material. These parts of the sanitary napkin preferably comprise part or all of the topsheet 38 and the absorbent core 42. These portions are represented schematically in Figures 63 and 64 by a single line.

The rear portion 194 of the cinch 190 is preferably also kept in close contact with the wearer's body, particularly with the wearer's gluteal groove. The cinch 190 should be of a shape that at least parts of it will fit within the perineal and gluteal grooves. In a preferred embodiment, the rear portion 194 of the cinch 190, when stretched, is in the form of a long, narrow strip.

The cinch 190 may, for example, if made from a soft, stretchable nylon or cotton fabric. In such a case, the rear portion 194 of the cinch 190 may be about 1 inch (about 2.5 cm.) wide. The length of the cinch measured from the end of the absorbent material in the sanitary napkin 20 to the cinch fastener 19G may be about 2 inches (about 5 cm.) when the cinch 190 is in an unextended condition.

116

The cinch 190 can be made from any suitable material. The material should preferably be soft, flexible, and absorbent. One material found to be suitable for use in the cinch 190 is a nylon panty fabric with some stretch present. The cinch 190 could, however, be made of materials that do not stretch.

The cinch 190 may have sections that stretch and sections that do not stretch. For example, FIG. 62 shows an embodiment in which a central zone 198 of the cinch 190 is capable of stretching to fit into the wearer's gluteal groove. The regions of the cinch 190 to either side of the central zone 198 (the zones at the ends of the cinch 202 and 204) are, however, not capable of stretching.

Preferably, the cinch 190 is extensible. The force required to stretch the cinch 190 a given distance is preferably less than the force required to stretch the wearer's panties the same distance. This allows the cinch 190 to remain against the wearer's body when the wearer's panties move. The force required to stretch the cinch 190 is preferably less than about 400 grams. The force required to stretch the cinch 190 may be as high as about 1,000 grams in some circumstances, such as if the wearer's panties are provided with higher elasticity.

The sanitary napkin 20 may be provided with a means for controlling the separation of the topsheet 38 and absorbent core 42 from the backsheet 40. Suitable such means are described in U.S. Patent 5,007,906. However, it need not have such a mechanism and the sanitary napkin also need not be constructed in accordance with U.S. Patent 5,007,906.

The sanitary napkin 20, however, is preferably at least provided with an alignment guide to keep the cinch 190 centered. Otherwise, the user might tend to pull the cinch 190 off to one side. The cinch 190 may not properly align with the wearer's perineal and gluteal grooves if this happens.

FIG. 62 shows one suitable, optional alignment guide that comprises a strip of material formed into a loop 200. The end of

117

the cinch 190 is kept on top of the backsheet 40 but under the loop 200 to keep the cinch 190 centered. (The loop 200 is omitted from the other drawing figures for simplicity of illustration.)

Figure 64 shows that the rear portion 194 of the cinch 190 has a free end (or "user's" end) 190C' which is attached to the inside of the wearer's panties U by the cinch attachment 196. The cinch attachment 196 can be any suitable type of fastener that can be affixed to the wearer's panties.

Suitable cinch attachments 196 can comprise the same basic types of fasteners described herein, such as adhesive fasteners and mechanical fasteners. The cinch fastener 196 could, thus, comprise an adhesive patch that adheres to the inside of the wearer's panties, or a patch of hook material which has hooks which engage the fabric of the wearer's panties.

The cinch fastener 196 is preferably not provided with the ability to stretch. It is preferred that the cinch 190 stay attached to the desired point inside the wearer's panties. This allows the cinch 190 to hold the absorbent portions of the sanitary napkin 20 firmly against the wearer's body when the wearer's panties stretch. If the cinch fastener 196 is able to stretch, this could cause the rear portion 194 of the cinch 190 to lose its ability to fit firmly adjacent to the wearer's gluteal groove.

The cinch 190 may be designed so that the attachment point may be selected by the wearer. In alternative embodiments, the cinch 190 may be used with specially designed panties so that the attachment point for the rear portion 194 is fixed. The attachment point could be pre-selected to aid the wearer in properly attaching the rear portion 194 to a specific point on her panties. For instance, the wearer's panties could be provided with a landing element for receiving the cinch fastener 196.

118

The cinch 190 can be fastened to many suitable places on the wearer's panties. The attachment point can be on the inside of the rear panel of the panties. If the cinch 190 is long enough or extensible enough, the attachment point can be in the area of the panty waistband, or even on the outside of the rear panel of the panties.

FIG. 64 shows an example of the latter type cinch 190. The cinch 190 has a mechanical cinch fastener 196 on its free end. The mechanical fastener 196 engages with a mating fastening element 206 on the inside of the wearer's panties. The mating fastening element shown can be a patch of loop material.

In other versions of this embodiment, the cinch fastener 196 and fastening element 206 could comprise some other type of mating (or complementary) fastening components. For example, the cinch fastener 196 could comprise an adhesive patch and the fastening element 206 could comprise a release coated bonding surface, such as a silicone-coated patch of polyolefinic material.

In addition, while it is ordinarily contemplated that the cinch fastener 196 will comprise the male element of a fastening system, this need not always be the case. The cinch fastener 196 could, for instance, comprise a patch of loop material that engages with a fastening element 206 that comprises a patch of hook material positioned on the inside of the wearer's panties.

In some alternative embodiments, the cinch 190 can be stored in a suitable manner prior to use. For instance, the cinch 190 can be folded and secured underneath the sanitary napkin so that it does not stick out prior to use. Alternatively, the cinch 190 can be inserted into a recess in the sanitary napkin similarly to the pull-out tab described above.

FIG. 66 shows another alternative embodiment in which the cinch 190 is provided in a pair of menstrual panties (or "menstrual shorts") 208 (that replace the wearer's usual panties) instead of being part of the sanitary napkin.

The cinch 190 could be a strip of material that is attached to the menstrual shorts at each end 190C' and 190C''. A sanitary napkin could be then be placed in and secured to the body-facing side 190A of the cinch 190, and the menstrual shorts pulled on by the wearer.

The strip of material that serves as the cinch should be attached to the menstrual shorts at places that are consistent with the principles described with relation to the versions of the cinch described above. For example, the front end 190C' of the strip should be attached to the menstrual shorts so that it lies anteriorly (or in front of) the wearer's anus, and preferably anteriorly to the wearer's vaginal introitus when the menstrual shorts are worn.

Menstrual shorts, such as those currently used by Japanese women, are preferred for use in embodiments with cinches because they are specifically designed to be worn during the menstrual cycle. Menstrual shorts also typically fit closer and tighter to the wearer's body than conventional panties.

The cinch 190 allows the sanitary napkin 20 to be pulled tightly as desired against the wearer's body. The more the cinch 190 is tightened by pulling it toward the waistband of the wearer's panties, the more secure it fits. The cinch 190 is referred to as such because it provides for tightening and adjusting similar to a girth for a pack or saddle.

The cinch 190 keeps the sanitary napkin 20 in sustained contact with the perineal and gluteal grooves. The cinch 190 operates in conjunction with the wearer's panties to provide sustained contact with the wearer's body. The cinch 190 preferably adjusts when the wearer and the panties move to provide continuous comfortable fit. This allows the sanitary napkin 20 to intercept menses near the vaginal introitus and along the top surfaces of the perineal and gluteal grooves.

F. Sanitary Napkin Having a Center Region That Deflects in Response to Stretching.

(1) General.

FIGS. 67-69 show an alternative embodiment of the sanitary napkin 20 of the present invention which has a center region 32 that deflects in response to stretching (and preferably lifts to provide improved body contact).

The sanitary napkin 20 is provided with a less extensible element, such as non-stretch element 216. The non-stretch element 216 is located approximately in the central region 32 of the sanitary napkin 20. As the sanitary napkin 20 is elongated, the central region 32 of the napkin narrows. This causes the non-stretch element 216 to bow or buckle and form a ridge 218 along the longitudinal centerline L of the sanitary napkin 20.

The non-stretch element 216 can generally be any type of component that is less extensible than at least some of the other parts of the main body portion 21 of the sanitary napkin 20. The non-stretch element 216 need not be completely inextensible, however. In the preferred embodiment described herein, however, it is relatively inextensible.

The material comprising the non-stretch element 216 should preferably not collapse inward (i.e., "squash" like a sponge) without providing any z-direction lift in response to the lateral compressive forces exerted on the sanitary napkin 20 during use. The structure into which the non-stretch element 216 is formed, however, preferably does compress and buckle in response to such forces.

The structure of the non-stretch element 216 is preferably rigid enough to allow bowing or buckling to occur when inwardly-oriented lateral compressive forces are applied to the longitudinal edges of the non-stretch element.

The non-stretch element 216 will preferably maintain sufficient rigidity when it is both dry and after it has become wet (such as by body exudates). Such a structure could be made from a blend of absorbent material and a fibrous material such as particular fibers known as CHISSO™ available from Chisso Corporation.

The non-stretch element 216 can be in the form of a layer of material, or in some other suitable form. The non-stretch element 216 has a body-facing side 216A, a garment-facing side 216B, a pair of longitudinal edges 216C, and a pair of end edges 216D.

The non-stretch element 216 may be made from any suitable material. The material should be soft, flexible, and absorbent, but rigid enough to bow or buckle. The non-stretch element 216 may be made from many of the basic types of absorbent core materials specified herein. These core materials, however, preferably should not be subjected to any process (such as ring rolling, pleating, corrugating, or slitting) to provide the material with extensibility. The non-stretch element 216 may, however, be designed to provide for buckling such as by folding (e.g., longitudinally), or the like.

The non-stretch element 216 is preferably simply placed on top of the core 42. It is preferably not affixed to the core 42 in any way. It is held in place by fitting snugly against the surrounding components of the sanitary napkin 20. However, it may be affixed at a single point on each of its longitudinal side edges.

Uniformly affixing the longitudinal side edges of the non-stretch element 216 to the absorbent core 42 can tend to negate the effect of stretching forces applied to the core 42. (The core 42 will be unable to stretch between affixation points since it would be affixed to an inextensible element.) This, in turn, will prevent the core 42 from transferring these forces to the non-stretch element 216. The non-stretch element 216 will then be unable to buckle.

It is possible to devise an arrangement where the non-stretch element 216 could be affixed to some component of the sanitary napkin, however. Such arrangements could still allow the components of the sanitary napkin to stretch. For instance, the non-stretch element 216 could be provided with an amount of excess or slack material. The slack material in the non-stretch element 216 could unfold or lengthen when the sanitary napkin is stretched. However, such embodiments are less preferred because they are more complicated.

The non-stretch element 216 is preferably of such a length that it does not extend into the end regions 28 and 30 of the sanitary napkin 20. It may in other embodiments. The non-stretch element 216 should preferably have a width that is equal to or greater than the core 42 or the inner longitudinal edges of the sanitary napkin. The width of the non-stretch element 216 preferably is such that the longitudinal side edges of the non-stretch element 216 abut against the inner longitudinal edges of the sanitary napkin. This will provide the desired snug contact with the other components of the sanitary napkin 20.

Executions having widths less than the core width or inner edges of the sanitary napkin are generally less preferred because it will make the transfer of forces to the non-stretch element 216 (described below) more difficult. In one preferred embodiment, the non-stretch element 216 is a layer of material that is square in plan view, and is about 2.5 inches by about 2.5 inches (about 6 cm. by about 6 cm.).

The longitudinal side edges 216C of the non-stretch element 216 are immediately adjacent portions of the topsheet 38 that lie along the longitudinal edges 22 of the sanitary napkin 20 (i.e., the inner longitudinal edges of the sanitary napkin). These edges are in contact with the portions of the inside surface of the topsheet 38 (or garment-facing side 38B of the topsheet). This allows the stretching forces applied to the absorbent core 42 to be transferred to the non-stretch element 216 to provide the desired lift.

The way these forces work is shown in FIGS. 70-73. FIG. 70 is a schematic cross-sectional view of a sanitary napkin 20 containing a non-stretch element 216.

FIG. 71 is a schematic perspective view of the non-stretch element 216 and absorbent core 42 shown in FIG. 70. FIG. 71 shows the longitudinally-oriented stretching forces F exerted on the sanitary napkin 20. These forces cause the width of the sanitary napkin 20 to narrow. This is due to the concept known as "necking" generally associated with the stretching of materials. The narrowing causes inwardly-oriented lateral forces F' to be exerted on the longitudinal side edges 216C of the non-stretch element 216.

The inwardly-oriented lateral forces F' are exerted by the other components of the sanitary napkin 20 (such as the topsheet) on the non-stretch element 216. The forces F' cause the non-stretch element 216 to buckle upward as shown in FIG. 72 (or downward in less preferred executions) since the non-stretch element 216 will not compress.

FIG. 73 shows that the inwardly-oriented forces F' must be exerted on the longitudinal edges 216C of the non-stretch element 216 by some suitable mechanism if the non-stretch element 216 is narrower than the core 42.

Various alternative embodiments of this sanitary napkin 20 are possible.

The restriction of the stretch to the central region 32 of the sanitary napkin 20 may be used to provide greater lift. This statement assumes (as illustrated in the drawing figures), that the total extensibility of the sanitary napkin is the same. This is shown schematically in FIGS. 74 and 75.

For instance, FIG. 74 represents a sanitary napkin 20 that is uniformly extensible. The top line in FIG. 74 represents the

124

sanitary napkin 20 in an unextended condition. The sanitary napkin 20 has an unextended length L_U . For the purposes of this example, L_U is set at 10 inches. The sanitary napkin 20 is uniformly extensible to a stretched length L_S of 12 inches. The center two inches of the sanitary napkin 20 which lies under the non-stretch element 216 will stretch 0.4 inches.

FIG. 75 represents a sanitary napkin 20 that has all of its stretch in the central region 32. The top line in FIG. 75 represents the sanitary napkin 20 in an unextended condition. The sanitary napkin 20 also has an unextended length L_U of 10 inches. The sanitary napkin 20 is also extensible to a stretched length L_S of 12 inches, but the end regions 28 and 30 are not extensible. The center two inch region of this sanitary napkin 20 will stretch a full two inches. The sanitary napkin 20 represented in FIG. 75 will provide the non-stretch element 216 with greater lift because it will narrow proportionately more in the central two inch region.

The non-stretch element 216 is preferably predisposed to buckle upward. This can be accomplished by many suitable mechanisms, including, but not limited to creasing, folding, placing ribs or inflexible sections in the non-stretch element 216, or by placing an optional small pre-formed lift element (shown in FIGS. 67-69) under the non-stretch element 216.

The pre-formed lift element 220 can be comprised of many suitable materials. The pre-formed lift element 220 may be an absorbent core material. The pre-formed lift element 220 does not have to be absorbent, however, if it is placed under the absorbent core 42. In one preferred embodiment, the pre-formed lift element 220 is a foam piece predisposed to buckle and fit under the absorbent core 42.

Suitable preformed lift elements could comprise the flexure-resistant deformation elements described in European Patent Application Publication Nos. 0 335 252 and 0 335 253

125

published in the name of Buell on October 4, 1989. In still other alternative embodiments, a flexure-resistant deformation element such as that described in the Buell EPO patent applications could take the place of the non-stretch element 216 or be placed under the core 42. Such a deformation element would have to be liquid pervious and sized and positioned as described herein.

(2) Alternative Embodiments.

FIG. 76 shows an alternative embodiment of a sanitary napkin 20 having a center region 32 that also lifts in response to stretching.

The embodiment shown in FIG. 76, however, provides a mechanism for lifting the center region 32 of the sanitary napkin 20 when relatively little or no longitudinally-oriented forces are exerted on the sanitary napkin 20.

This embodiment uses the laterally outward-oriented forces that tend to stretch the sanitary napkin laterally in the area of the wearer's buttocks. This sanitary napkin 20 transfers these laterally-outward oriented forces to stretch the pad longitudinally in the center region 32 under the genital area. In other words, the forces exerted on the sanitary napkin 20 when the wearer sits or squats are used to lift the center region 32.

The sanitary napkin 20 shown in FIG. 76 comprises at least some of the same basic components described above. These include a topsheet 38, a backsheet 40, and an absorbent core 42. These components of the sanitary napkin 20 should, preferably, be extensible (more preferably stretchable) in all directions.

The sanitary napkin 20 also has a less extensible element 216. The less extensible element 216, as noted above, can be any suitable component that is less extensible than at least some of the other parts of the main body portion 21 of the sanitary napkin 20. The less extensible element 216 is preferably positioned

126
between the topsheet 38 and the absorbent core 42. The less extensible element 216 can, however, be positioned between any of the components described herein, provided it overlies the force transferring member (described below).

The sanitary napkin 20 is provided with a force transferring element. The force transferring element shown in FIG. 76 comprises a pleated foam layer 230. The pleated foam layer 230 is positioned between the less extensible element 216 and the backsheet 40 in the embodiment shown in FIG. 76.

The pleated foam layer 230 can comprise one of the basic components of the sanitary napkin. The pleated foam layer 230 could, for example, comprise all or part of either the absorbent core 42, or the backsheet 40. Alternatively, the pleated foam layer 230 can be a separate element. For instance, the pleated foam layer 230 could be a separate element located on top of the absorbent core 42, under the absorbent core 42, or within the absorbent core 42.

The pleated foam layer 230 shown in FIG. 76 preferably comprises at least two distinct regions.

The first region is a central extensible region, such as central pleated region 232. The central extensible region 232 is longitudinally extensible. The central extensible region 232 can be made longitudinally extensible in any of the manners described herein.

Preferably, the central extensible region 232 is pleated, corrugated, or the like. The central pleated region 232 has fold lines 233 that run generally in the transverse direction. This permits the central pleated region 232 to stretch longitudinally.

The second region is a rear laterally extensible region, such as the rear pleated region 234 (or pleated "buttocks region") of the pleated foam layer 230. The rear pleated region 234 comprises

127

a pleated portion 236 and at least one force transferring member 238.

The pleated portion 236 of the rear pleated region 234 comprising the rear pleated region is pleated, corrugated, or the like with fold lines 237 running generally in the longitudinal direction. This permits the pleated portion 236 of the rear pleated region 234 to stretch transversely. The pleated portion 236 is divided into three sections by the force transferring member 238. These are first section 240, second section 242, and third section 244.

The force transferring member in FIG. 76 comprises a pair of non-extensible (or "inextensible") ribs 238. The non-extensible ribs 238 run diagonally from the corners of the rear pleated region 234. The ribs 238 extend to the intersection of the boundary between the central and rear pleated regions, 232 and 234, and the longitudinal centerline of the pleated foam layer. The ribs 238 need not intersect with the longitudinal centerline. They should, however, extend to the boundary between the central and rear pleated regions, 232 and 234, or be connected to some type of inextensible element that extends to that boundary. This permits the forces exerted on the force transferring member to be applied to the central pleated region 232.

The non-extensible ribs 238 (or other type of force transferring member) can comprise any type of component that is inextensible or less extensible than the surrounding pleated portions 236.

The ribs 238 could simply comprise portions within the boundary of the rear pleated region 234 that are unpleated. The ribs 238 could alternatively comprise thickened portions of the foam layer 230. The ribs 238 could be formed integrally with the foam layer 230, or they could comprise separate elements added to the foam layer 230.

128

The pleated foam layer 230 could also be provided with an optional front region. The front region could be in many suitable configurations. For instance, it could be a mirror image of the rear pleated region 234. Alternatively, it could resemble the rear pleated region without the non-extensible ribs. In still other alternatives, it could be pleated in another direction, non-pleated, or inextensible.

The sanitary napkin 20 is particularly suitable for effectively using the forces exerted on the sanitary napkin 20 when the wearer sits or squats to lift the center region 32. When the wearer sits or squats, the forces exerted on the sanitary napkin are transversely-oriented stretching forces F_T on the rear pleated region 234. These forces cause the pleated regions 240, 242, and 244 of the rear pleated region 234 to stretch transversely as shown in FIG. 79.

FIG. 79 shows that a component of these forces F_C is exerted on the non-extensible ribs 238. This force F_C on the ribs 238 causes the central pleated region 232 to stretch longitudinally. This narrows the central pleated region 232. The narrowing of the central pleated region 232, as described above, causes the overlying less extensible element 216 to buckle upward.

In other embodiments, the force transferring element 230 can comprise many other materials in addition to foams. The only requirement is that the force transferring element 230 have one or more relatively inextensible structure that is capable of translating one of the components of the laterally-outward oriented forces exerted on the rear of the sanitary napkin into longitudinally-oriented stretching forces.

FIGS. 80-81 show another alternative embodiment, similar to that shown in FIG. 76.

The embodiment shown in FIGS. 80-81 differs in that it is also provided with a spacing structure 250. The spacing structure 250 is capable of spacing the topsheet 38 away from the absorbent

core of the sanitary napkin 20 in response to inwardly-oriented lateral compressive forces F_1 , such as those exerted on the product by the upper portions of the wearer's thighs during use. The spacing structure 250 is described in greater detail in Canadian Patent Application Serial No. 2,093,350 filed in the name of Visscher, et al. on October 18, 1991.

The spacing structure 250 uses the inwardly-oriented lateral compressive forces F_1 forces to provide improved contact of the absorbent component with the wearer's body. The force-transferring element will serve this purpose in the absence of inwardly-oriented compressive forces. Thus, this embodiment is intended to be able to provide contact with the wearer's body throughout a range of the wearer's movements.

G. Sanitary Napkin Having a Pop-Up Center.

FIGS. 82-83 show an alternative embodiment of the sanitary napkin of the present invention that has a pop-up center.

The pop-up center in the embodiment shown is provided by a pop-up element 260. The pop-up element 260 can be conceptualized as being a nonalagous, but related version of the pages in children's "pop-up" books.

The pop-up element 260 can be used to assist portions of the sanitary napkin 20 in fitting in the space between the wearer's labia. The pop-up element 260 can comprise a foam piece 262 that has concentric oval cuts 264 therein. The cuts 264 should only partially form an oval shape so that the oval-shaped rings 268 between each cut 264 are bridged by the foam. That is, uncut spaces 266 are provided adjacent the cuts. Otherwise, the rings 268 would separate.

Any other shape cuts that create elements that pop up in response to forces of the type exerted on a sanitary napkin during

130

wear can also be used. Different configurations can be used to create particular shapes to conform to different regions of the wearer's body.

The foam piece 262 shown in FIGS. 82 and 83 is a separate element positioned on top of the absorbent core 42. In other embodiments, the foam piece 262 can be positioned between various other components of the sanitary napkin 20. The foam piece 262 could be located on top of the absorbent core 42, under the absorbent core 42, or within the absorbent core 42.

In still other embodiments, the foam piece 262 can comprise one of the basic components of the sanitary napkin. The foam piece 262 could, for example, comprise all or part of either the absorbent core 42, or the backsheet 40.

The foam piece 262 can be combined with other features to help it pop-up properly.

FIG. 83 shows an embodiment in which the sanitary napkin 20 is provided with pleats having longitudinally-oriented fold lines across its entire surface. The sanitary napkin 20 is also provided with non-extensible ribs 272, similar to those in the embodiment shown in FIG. 76. The non-extensible ribs 272 allow the foam piece 262 to pop up in response to laterally or longitudinally-oriented stretching forces. Many other configurations containing all or only portions of these additional features are also possible.

The embodiments described in this section (and numerous other sections of this specification) can all be provided with a decoupling feature as described in the aforementioned Visscher, et al. patent application or a flexure-resistant deformation element as described in the aforementioned European Patent Application publication numbers 0 335 252 and 0 335 253 published October 4, 1989 in the name of Kenneth B. Buell to assist the sanitary napkin in providing increased body contact and in assuming certain configurations.

H. Sanitary Napkin Having Regions of Differential Extensibility.

Figures 84 and 85 show a sanitary napkin 20 that has regions of differential extensibility (or more preferably, differential stretch).

The sanitary napkin 20 has distinct regions where different elastic moduli allow the sanitary napkin to stretch in different amounts to conform to different regions of the perineal region of the wearer's body. This is believed to lead to improved protection and comfort. The regions with different elastic moduli may differ in that they require different amounts of force to extend and/or to return toward their unextended dimensions.

The sanitary napkin 20 can, for example, comprise the following components from top to bottom. A strip designated 280, of 1.1 mil (preferably apertured) EXX-7 film is provided along each longitudinal edge 22 of the sanitary napkin. The strips 280 of extensible film could simply be secured on top of the topsheet 38 along its longitudinal edges 38C. Alternatively the strips 280 could be wrapped around the longitudinal edges 22 of the sanitary napkin.

The topsheet comprises a ring rolled formed film that has transversely oriented pleat lines. The absorbent core comprises a layer of stretch cotton fabric. In another alternative embodiment, the core could comprise absorbent gelling materials contained between two layers of highly creped tissue. The backsheets comprises an elastic or stretchable material such as 5 mil Findley stretchable adhesive film #198-338. The sanitary napkin has intermittent patches of panty fastening adhesive for securing the sanitary napkin to the wearer's panties. The panty fastening adhesive patches are covered by a single conventional non-elastic sheet of release paper.

132

The sanitary napkin 20 is provided with two regions of differential extensibility. The term "regions of differential extensibility", as used herein, refers to regions of the sanitary napkin (or other absorbent article) that are extensible in response to different amounts of stretching force applied in a certain direction. In other words, the regions of differential extensibility have different elastic moduli.

The regions of the sanitary napkin 20 shown in FIG. 84 comprise a region of first extensibility (or simply "first region") 290, and a pair of regions of second extensibility (or "second regions") 292.

The region of first extensibility 290 comprises the large rectangular portion of the sanitary napkin 20 that lies along the longitudinal centerline. This is the portion of the sanitary napkin 20 that does not have the strips 280 of elastic film overlying it. The region of first extensibility 290 has a first unextended dimension. It also has a first extended dimension when forces act to extend the first region 290.

The regions of second extensibility 292 comprise the narrow rectangular-shaped portions of the sanitary napkin 20 that lie along the longitudinal side regions 36 of the sanitary napkin 20. These are the portions having the overlying strips 280 of elastic film. The second regions 292 have a second unextended dimension. They have a second extended dimension when forces act to extend the second regions 292.

In other embodiments, the regions of differential extensibility can be of any shape and in any location. The regions of differential extensibility may be extensible in any direction. In addition, in other alternative embodiments, the sanitary napkin 20 may have more than two regions of differential extensibility. These may be designated as regions of first, second, third, etc. extensibility.)

133

The regions of differential extensibility, such as the first and second extensibility 290 and 292 shown, have extensibility characteristics within those specified for the overall sanitary napkin (or other absorbent article) in this specification.

The sanitary napkin 20 is, thus, distinguishable from sanitary napkins or other absorbent articles with elastic strands along their longitudinal side edges. These two types of absorbent articles differ in a number of ways. These include, but are not limited to, the following.

The sanitary napkins of this embodiment of the present invention do not require elastic strands for their extensibility. (They may, of course, be provided with optional elastic strands, however.)

Further, sanitary napkins with elastic strands along their longitudinal side edges are typically only capable of extension in the area of the elastic strands. The sanitary napkins of the present invention are generally extensible at regions other than those regions that contain elastic strands and the immediately surrounding regions that are gathered by such elastic strands. For all practical purposes, the elastic strands in such absorbent articles, and the surrounding regions that are gathered by the elastic strands, may be considered as having only a single region of extensibility.

The sanitary napkin 20 having regions of differential extensibility is characterized by the fact that the force required to extend the regions of second extensibility 292 is different from the force required to extend the region of first extensibility 290 the same distance in the same direction. The force required to extend the first region can be either greater than, or less than, that required to extend the second region the same distance in the same direction.

134

The embodiment of the sanitary napkin 20 having the strips 280 of elastic film simply overlying and secured along the longitudinal side margins 36 has second regions 292 with less extensibility. (In other words, the force required to extend the second regions 292 a given distance is greater than that of the first region 290.)

The forces required to extend the regions of second extensibility 292 are greater because where the strips 280 are secured to the longitudinal side regions 36, the modulus of elasticity of the resulting second regions of extensibility 292 is equal to the sum of the modulus of elasticity of the sanitary napkin and the modulus of elasticity of the strips 280.

In the other example discussed above, the force required to extend the regions of second extensibility 292 is less than that required to extend the region of first extensibility 290.

The regions of differential stretch are useful in allowing the sanitary napkin 20 to assume particular configurations when worn.

Figures 86 and 87 are cross-sectional views that show a "boat" configuration that the sanitary napkin shown in Figures 84 and 85 is capable of assuming in use. The boat configuration is characterized by upstanding longitudinal side regions and end regions. This configuration could, for instance be used for containment of exudates.

Other configurations are useful to provide the sanitary napkin with selective penetration of the gluteal groove, on the labia.

The sanitary napkin 20 shown in Figures 84 and 85 could have regions of differential extensibility that are opposite those of the sanitary napkin described above. This could occur if the strips 280 extend at least partially outward from the rest of the sanitary napkin along the longitudinal side edges 22.

The strips 280 could form such an extension by simply displacing them laterally outward before securing them to the other components of the sanitary napkin 20. Alternatively, the strips 280 could be wrapped around the longitudinal side edges 22 of the sanitary napkin 20 so that at least parts of the strips 280 extend outward from the other components of the sanitary napkin 20.

The sanitary napkin in such a case would have a longitudinal central region 34 that has less extensibility than the longitudinal side regions 36. The modulus of elasticity of the highly elastic EXX-7 elastic film in these latter cases would not be added to that of the rest of the sanitary napkin.

A sanitary napkin constructed in this manner would have a central region 34 that would assume the opposite configuration of that shown in FIGS. 86 and 87 when worn. (That is, it would look like these figures turned upside down.) Such a sanitary napkin could be useful to increase the contact of the longitudinal central region 34 with the wearer's body. Thus, it is apparent that components, such as the strips 280, can be added to the sanitary napkin 20 to modify the extensibility of different regions of the sanitary napkin 20.

The sanitary napkin 20 can be provided with regions of differential stretch in other ways. Modifications can be made to the backsheet, panty fasteners, absorbent core, or the topsheet.

Figures 24 to 27 show examples of sanitary napkins 20 that have panty fasteners in different patterns to provide different stretch properties. The panty fasteners can be any of the types of fasteners described in Section 3F(1)(b) above.

Figure 28 shows an example of a sanitary napkin having a corrugated backsheet modified to create regions of differential extensibility. The sanitary napkin 20 has one corrugated triangular-shaped region 300 in each end region.

These triangular-shaped regions 300 have bases which coincide with the transverse end edges 24 of the sanitary napkin. The apex of each triangular shaped region is located along the longitudinal centerline. The apexes are oriented toward the intersection of the longitudinal and transverse centerlines. The apexes do not extend all the way to the transverse centerline T in this embodiment, although in other embodiments they may.

The remaining portion of the sanitary napkin, designated 302, could be less extensible than the portions of the sanitary napkin containing the triangular-shaped regions 300.

This sanitary napkin embodiment could be used to provide the sanitary napkin with selective lift. The triangular regions of the sanitary napkin will tend to stretch to fit the shape of the mons region and the gluteal groove when the sanitary napkin is worn. The remaining portion 302 of the sanitary napkin 20 could lift to fit closer to the wearer's labia.

FIGS. 29-31 show examples of absorbent cores 42 that can provide the sanitary napkin with differential extensibility.

FIG. 29 shows an absorbent core 42 provided with extensible end regions 28 and 30, and a less extensible, or inextensible central region 32.

FIG. 30 shows an absorbent core 42 that has a trapezoidal-shaped area in the longitudinal central region 34 that is less extensible than the surrounding longitudinal side regions 36 and end regions 28 and 30. This trapezoidal area can comprise a less extensible material. In an alternative embodiment, it could simply be a hole in the absorbent core 42 (provided, of course, that there is some suitable arrangement of components that is capable of handling liquids deposited over the portion of the core 42 containing the hole).

FIG. 31 shows an absorbent core 42 that is provided with an extensible region that comprises the majority of the core 42, with the exception of those portions that lie within the corner regions 27 of the sanitary napkin. The extensible region comprises a longitudinal central region 34 that runs the length of the core 42, as well as the central region 32, and portions of the end regions 28 and 30.

The various different examples sanitary napkins with regions of differential extensibility have been described with respect to certain specific components, such as the backsheet, the panty fastener, and the core.

It should be understood, however, that the sanitary napkin (and other absorbent articles) with regions of differential extensibility is not limited to the examples shown in the drawings. For instance, any of the components of the sanitary napkin can be used to provide the sanitary napkin with regions of differential extensibility. Such regions of differential extensibility can be similar to those shown in the drawings for one of the other components. In other embodiments, they can comprise regions of wholly different configurations than those shown in the drawings.

I. Other Alternative Embodiments.

In still other alternative embodiments, components of regions of the sanitary napkin may be further structurally modified by folding, bending, corrugating, stacking of layers and affixing layers to each other. The modifications may be made by including one or more of the structures described in the aforementioned European patent applications published in the name of Buell, in the aforementioned Canadian patent application filed in the name of Visscher, et al., and in Canadian Patent Application Serial No. 2,118,215 entitled "Generally Thin, Flexible Sanitary Napkin" filed in the name of Osborn on April 19, 1983.

In still other alternative embodiments, the sanitary napkin could be provided with additional components. For instance, the sanitary napkin could be provided with the wet-laid tissue and/or the liquid permeable wipe acquisition sheet described in greater detail in U.S. Patent 5,009,653 issued to Osborn.

In yet other alternative embodiments, the sanitary napkin could be provided in a curved, shaped configuration such as that described in the following patent applications filed July 23, 1992: Canadian Patent Application Serial No. 2,092,197, entitled "Curved, Shaped Absorbent Article" filed in the name of Theresa L. Johnson, et al.; Canadian Patent Application Serial No. 2,092,202, entitled "Absorbent Article Having Resilient Center" filed in the name of Thomas W. Osborn, et al.; Canadian Patent Application Serial No. 2,092,204, entitled "Absorbent Article Fastener Pattern" filed in the name of Robb E. Olsen, et al.; and Canadian Patent Application Serial No. 2,092,203, entitled "Method of Making Curved, Shaped Absorbent Article" filed in the name of Letha M. Hines, et al.

Thus, while the sanitary napkins of the present invention may typically be comprised of components that extend together to a sufficient degree when stretched such that the extended configuration of the sanitary napkin is not curved, in other embodiments the extension of the components could result in a curved product.

While several preferred sanitary napkin embodiments have been described, numerous other sanitary napkin embodiments are disclosed in the literature. These could be provided with the stretch properties of the present

138a

invention. Some of such sanitary napkins are described in Canadian Patent Application Serial No. 2,093,350 filed October 18, 1991 in the name of Visscher, et al., U.S. Patents 5,009,653 and 4,950,264, issued to Osborn on April 23, 1991 and August 21, 1990, respectively, U.S. Patent 4,940,462, issued to Salerno on July 10, 1990, U.S. Patent

4,917,697 issued to Osborn, III, et al. on April 17, 1990, U.S. Patent 4,911,701 issued to Mavinkurve on March 27, 1990, U.S. Patent 4,900,320, issued to McCoy on February 13, 1990, U.S. Patent 4,687,478 issued to Van Tilburg on August 18, 1987, U.S. Patent 4,608,047 issued to Mattingly on August 26, 1986, U.S. Patent 4,589,876 issued to Van Tilburg on May 20, 1986, U.S. Patent 4,285,343 issued to McNair on August 25, 1981, U.S. Patent 3,397,697 issued to Rickard on August 20, 1968, and U.S. Patent 2,787,241 issued to Clark on April 2, 1957.

The terms "panty liner" or "pantiliner" refer to absorbent articles that are less bulky than sanitary napkins which are generally worn by women between their menstrual periods. Suitable absorbent articles in the form of pantliners are disclosed in U.S. Patent 4,738,676 entitled "Pantiliner" issued to Osborn on April 19, 1988.

The term "incontinent article" refers to pads, undergarments (pads held in place by a suspension system of same type, such as a belt, or the like), inserts for absorbent articles, capacity boosters for absorbent articles, briefs, bed pads, and the like, regardless of whether they are worn by adults or other incontinent persons. Suitable incontinent articles that can be provided with the extensible components described herein are disclosed in U.S. Patent 4,253,461 issued to Strickland, et al. on March 3, 1981; U.S. Patents 4,597,760 and 4,597,761 issued to Buell; the above-mentioned U.S. Patent 4,704,115; U.S. Patent 4,909,802 issued to Ahr, et al.; U.S. Patent 4,964,860 issued to Gipson, et al. on October 23, 1990; and in Canadian Patent Applications Serial Numbers 2,098,322 and 2,098,502 filed respectively by Noel, et al. and Feist, et al. on December 20, 1991.

The focus of the present invention is on absorbent articles that are intended to be worn in the crotch region of the wearer's undergarments. However, the features of the present invention could also be used in absorbent articles such as diapers. Diapers are absorbent articles worn by infants and incontinent persons that are fastened about the waist of the wearer.

Suitable diapers that can be provided with the extensible features described herein are disclosed in U.S. Patent 3,860,003 issued to Buell on January 14, 1975, and Canadian Patent Application Serial No. 2,112,400 filed in the name of Buell, et al. on July 3, 1992.

5. Test Methods

The extensibility of the sanitary napkin (or other absorbent article) is measured on EME Tensile Tester, Model No. 559A available from EME, Inc., P.O. Box 187, Newbury, OH 44065, a constant rate of elongation tensile testing apparatus.

The EME Tensile Tester is provided with a computer that provides an LCD readout of the distance the ends of the clamps are spaced from a reference home position and the forces on the sample when the clamps are spaced various distances from the home position.

All tests are performed at 50% humidity and at 73°F. The samples are carefully handled to avoid any stretching of the same prior to performing the test. The tests should each be repeated with samples taken from five separate products of the same type. If any of the samples fall within the claimed range or limit, the product will be considered to fall within the scope of the appended claims.

141

A. Method to Measure Extensibility of One Inch (2.5 cm.) Center Strip.

Step 1

Sample for Measuring Longitudinal Extensibility

Cut a 1.0 inch (2.54 cm.) wide strip from the center of the absorbent article using a JDC Precision Sample Cutter, Model #1-12 available from Thwing-Albert, Philadelphia, PA. The strip used as the sample for this method should be cut along the longitudinal centerline of the absorbent article. The length of the strip should run the full length of the portion of the absorbent article from which the sample is taken.

Sample for Measuring Transverse Extensibility

A 1.0 inch wide strip is cut from parallel to the transverse centerline of the absorbent article using the JDC sample cutter. The strip used as the sample for measuring the transverse extensibility can be cut through any one inch wide section of the absorbent article that runs parallel to the transverse centerline. The sample need not run along the transverse centerline.

The sample should, however, be cut through a portion of the absorbent article so that the entire one inch width of the sample consists of at least one of the absorbent components of the absorbent article. (The term "absorbent component" is defined below.) Thus, the sample should not be cut so close to one of the transverse end edges of the absorbent article that the sample contains portions of the absorbent article at the end seal.

Samples for Measuring Both Longitudinal and Transverse Extensibility

A sample for measuring longitudinal extensibility should be cut from a first sample absorbent article. The sample for

142

measuring transverse extensibility should be cut from a second sample absorbent article of the same type as the first (i.e., an identical product). (The same applies to any of the other tests described herein when a sample is cut out of the product to measure extensibility in a given direction.)

Step 2

Remove any adhesive cover strip from the sample. If the sample has an adhesive fastener, eliminate any adhesive tack by dusting the adhesive fastener with talc or corn starch.

Step 3

Lay the sample unrestrained on a table with the body surface facing upward. Measure the length of the sample to the nearest 0.1 inch (0.25 cm.).

The length of the sample, for the purpose of the appended claims, is the dimension of the sample that runs perpendicular to the one inch width dimension. The length of the sample is obtained by measuring the length of the absorbent components of the sample. (This can be contrasted with determining the length of the sample by simply measuring the overall length of the sample.)

The length of the sample is equal to the length of the longest absorbent component of the sample. If the sample is folded or curved (i.e., when it is removed from its package), flatten the ends of the sample prior to measuring the length of this absorbent component. The sample is flattened by placing a ruler on top of the sample and gently pressing down on the portion of the ruler that covers the ends of the sample until the garment surface at the ends lies flat against the table.

143

The term "absorbent component", as used herein, refers to components that are generally used as the primary absorbent component of the product, such as the absorbent core of the product. It also includes absorbent components, such as the secondary topsheets described herein that serve a wicking or storage function. The term absorbent component, however, excludes components that are generally only used as the topsheet or backsheet of the absorbent article.

The measurement of the length of the longest absorbent component taken above should not include any portions of the absorbent component that may be located outboard of, or within any end seal on the sample because these portions of the absorbent component typically serve no absorptive function.

Step 4

Clamp each end of the sample in the tensile testing apparatus using 3 inch (7.6 cm.) wide clamps. The clamps of the tensile tester are set so that they will be pulled away from each other in opposite directions (that is, they will pull at an angle of 180 degrees). The sample should be centered in the clamps and the clamping pressure should be sufficient to prevent any slippage of the sample in the clamps (this applies to all of the test methods).

The sample should be clamped so that the outermost edge (i.e., the free end) of the clamps are approximately 0.5 inches (about 1.3 cm.) inward from the end edges of the longest absorbent component. The portions of the sample that may be located within or outboard of an end seal on the sample are excluded when determining the location of the end edges of the longest absorbent component for placing the clamps of the testing apparatus on the sample.

144
Step 5

Set the gauge length of the tensile tester to the length of the absorbent component (as measured above) less the amount of absorbent component material clamped into each of the clamps (typically 1 inch). Initiate the elongation with a cross head speed of 0.367 inches per second (0.93 cm. per second).

When the sample reaches the gauge length, tare the load cell of the testing apparatus to zero. Set the trigger point to begin collecting data at 20 grams force. (The application of this initial 20 gram force typically pulls out at least some of any slack that may exist in the sample.)

The force and extensibility measurements are taken at the desired times, and the test is completed. The initial length of the sample is the measured length of the longest absorbent component. The force, for the purpose of the appended claims, is the actual force reading on the testing apparatus when the above procedure is followed.

The cutting of the 1.0 inch strips is intended to minimize the effect of any elastic strands in the longitudinal side margins of the absorbent article on the results of the test. (The absorbent articles of the present invention are preferably free of such elastic strands. Optional elastic strands can, however, be added.)

When measured according to this test, 1.0 inch strip of the absorbent article is preferably capable of extension in the longitudinal direction of greater than or equal to about 105%, 110%, 115%, 120%, 125%, or more, of its initial length when subjected to a force of less than or equal to about 20, 50, 100, 150, 200, 300, 400, or 500 grams. The 1.0 inch strip of the absorbent article is preferably capable of extension in the

145

transverse direction when subjected to forces of the same amounts. The strip can have a maximum extension under these forces of up to 110, 120%, 130% 140%, 150%, 160%, 170%, 180%, 190%, 200%, or more. The limits specified in this specification can be combined in any manner in the appended claims.

The absorbent article may be capable of such extension as measured by a 1.0 inch strip in both the longitudinal and transverse directions. In such a case, the absorbent article is preferably extensible in the amounts specified in the foregoing paragraph.

Although the absorbent article can be of any length, preferably, the absorbent article is worn in an undergarment and has a longest absorbent component, such as an absorbent core, with an initial length of less than or equal to about 12.0 inches. The width of the absorbent component of the absorbent article is preferably less than or equal to about 3.0 inches, and is more preferably less than or equal to about 2.5 inches. (Diapers, on the other hand, typically have absorbent cores greater than about 12.0 inches in length and 3.0 inches in width.) In addition, in some embodiments, the absorbent article may have a caliper of less than or equal to about 5 mm.

The absorbent article preferably has a force wall such that the strip requires a force greater than or equal to 1,000 grams to extend beyond 160%, 150%, 140%, 130% of its initial length, or one of the other lengths specified above.

The absorbent article is preferably also elastically extensible or permanently deformable such that when the strip is extended to one of the above lengths, it is capable of recovering to a recovered dimension that is less than or equal its extended length when the extending forces are removed.

B. Method to Measure Extensibility of Absorbent Article.

The sample used for this test is the entire absorbent article. This test is used only to measure the longitudinal extensibility of the absorbent article. The transverse extensibility is measured according to the preceding test method.

The entire absorbent article used as the sample in this test should be tested following steps (2) - (5) above, with the following additional instruction when carrying out step (3).

If the sample cannot be conveniently flattened (such as due to the presence of contracted elastics), the length of the longest absorbent component should be measured by allowing the sample to unfold (if it is folded) and holding the sample in the curved configuration that the sample is in when it is taken out of the box, and measuring the length of the longest absorbent component with a tailor's cloth tape measure along the arc formed by the garment surface of the absorbent article.

The absorbent article is preferably capable of extension in the longitudinal direction (i.e., along the longitudinal centerline) of greater than or equal to about 105%, 110%, 115%, 120%, 125%, 130%, 140%, 150%, 160%, 170%, 180%, 190%, 200%, or more, of its initial length when subjected to a force of less than or equal to about 20, 50, 100, 150, 200, 300, 400, 500, 600, 700, 800, 900, 1,000, or more grams. (The forces for longitudinal extensibility may be higher than those measured on the 1.0 inch strip by the previous test since the entire absorbent article is used in this second test.)

The absorbent article preferably has a force wall such that the strip requires a force greater than or equal to 1,200, 1,500 or 2,000 grams to extend beyond 160%, 150%, 140%, 130% of its initial length, or one of the other lengths specified above.

C. Method to Measure Stretch Relative to Product Shear from an Undergarment.

1. First Method -- 20 Gram Trigger.

The sample used for this test is the entire absorbent article.

Lay the sample unrestrained on a table with the body surface facing upward. Measure the length of the longest absorbent component of the sample to the nearest 0.1 inch (0.25 cm.). Follow the same instructions for measuring the absorbent component in step (3) of Test Methods A and B above. This test, however, is only concerned with the measurement of properties of the sample in the longitudinal direction (i.e., parallel to the longitudinal centerline).

If the sample has an adhesive fastener, remove any adhesive cover strip from the sample. Take a strip of cotton fabric #429W (standard 3 inch width) manufactured by Test Fabrics, Inc. of Middlesex, NJ, and cover 1.0 inch (2.54 cm.) of the fastener at one end of the fastener.

The sample can be placed under an ultraviolet lamp to aid in determining the end of most adhesive fasteners. Eliminate any adhesive tack on the remainder of adhesive fastener by dusting the uncovered portion of the adhesive fastener with talc or corn starch.

The strip of cotton fabric should be long enough so that its free end (unattached end) extends at least 0.5 inch (1.3 cm.) beyond the end edge of the sample (i.e., the actual end edge of the product including absorbent and nonabsorbent components) adjacent to the 1 inch portion of the fastener that the cotton strip covers.

148

Apply 0.25 psi. of pressure for a period of 30 seconds uniformly (with a weight) to the cotton surface to attach the cotton fabric to the fastener. If the panty fastener is not adhesive, attach the sample to the cotton fabric in the manner the fastener would ordinarily be placed in the wearer's undergarment.

Clamp the end of the sample that is not attached to the cotton strip in the tensile testing apparatus using a 3 inch (7.6 cm.) clamp. The sample should be clamped so that the outermost edge (i.e., the free end) of the clamp is approximately 0.5 inches (about 1.3 cm.) inward from the end edge of the absorbent component. If there is more than one absorbent component, the sample should be clamped so that all of the absorbent components are grabbed by the clamp. In other words, the sample is clamped about 0.5 inches from the end of the absorbent component(s).

Place the free end of the cotton strip into the other 3 inch clamp. The free end of the cotton strip is placed in this clamp so that the free end of the clamp just comes into contact with the nearest end edge of the sample. The clamps of the tensile tester are set so they will pull at 180 degrees (as in the preceding tests). This will impart shearing forces which tend to separate the fastener and the cotton strip from each other.

Set the gauge length of the tensile tester to the length of the absorbent component (measured above) less the amount of absorbent component material clamped into each of the clamps (typically about 0.5 inch). Initiate the elongation with a cross head speed of 0.367 inches per second (0.93 cm. per second). When the sample reaches the gauge length, tare the load cell of the testing apparatus to zero. Set the trigger point to begin collecting data at 20 grams force.

The force and extensibility measurements are taken at the desired times, and the test is completed.

The absorbent article is preferably capable of extending at least about 110%, 115%, 120%, 125%, 130%, 140%, etc. of its initial length before it is subjected to a force of an additional 1,000 grams, or before the forces exerted on the sample cause the fastener to separate from the cotton fabric when tested under the above test (Test Method (C)(1)).

2. Second Method -- 50 Gram Trigger.

The sample used for this test is the entire absorbent article. This test is only concerned with the measurement of properties of the sample in the longitudinal direction (i.e., parallel to the longitudinal centerline).

Lay the sample unrestrained on a table with the body surface facing downward. If the sample has an adhesive fastener, peel back enough of any adhesive cover strip to expose about 2 inches (about 5 cm.) of adhesive on one end of the sample.

Take a strip of cotton fabric #429W (standard 3 inch width) manufactured by Test Fabrics, Inc. of Middlesex, NJ, and cover 1.0 inch (2.54 cm.) of the (exposed) fastener material at the end of the fastener. The sample can be placed under an ultraviolet lamp to aid in determining the end of most adhesive fasteners. The portion of the fastener covered by the cotton should be representative of the fastening surface. Just place the cotton strip on the fastener. Do not apply pressure at this point.

The strip of cotton fabric should be long enough so that its free end (unattached end) extends at least 0.5 inch (1.3 cm.) beyond the end edge of the sample (i.e., the actual end edge of the product including absorbent and nonabsorbent components) adjacent to the 1.0 inch portion of the fastener that the cotton strip covers. A strip of cotton which extends about 3 inches (about 7.6 cm.) beyond the end edge of the sample is sufficient for many samples.

150

Measure and mark a transverse line 0.5 inch (1.3 cm.) from the edge of the longest absorbent component at the opposite end of the sample (the end that will be the attached end of the sample). This mark serves as a guide for the location of the clamp of the tensile tester at this end of the sample.

Apply 0.25 psi. of pressure for a period of 30 seconds uniformly (with a foam-covered weight) to the cotton surface to attach the cotton fabric to the fastener. If the panty fastener is not adhesive, attach the sample to the cotton fabric in the manner the fastener would ordinarily be placed in the wearer's undergarment. Remove the weight. Remove any remaining release paper. Eliminate any adhesive tack on the remainder of any adhesive fastener. This may be done by dusting the uncovered portion of the adhesive fastener with talc or corn starch.

Clamp the end of the sample that is not attached to the cotton strip in the tensile testing apparatus using a 3 inch (7.6 cm.) clamp. The sample should be clamped so that the outermost edge (i.e., the free end) of the clamp is 0.5 inches (1.3 cm.) inward from the end edge of the absorbent component. If there is more than one absorbent component in the 1/2 inch region, the sample should be clamped so that all of the absorbent components are grabbed by the clamp. In other words, the sample is clamped 0.5 inches from the end of the absorbent component(s).

Place the free end of the cotton strip into the other 3 inch clamp. The free end of the cotton strip is placed in this clamp so that the free end of the clamp just comes into contact with the nearest end edge of the sample. Care should be taken not to clamp any portion of this end of the sample. The clamps of the tensile tester are set so they will pull at 180 degrees (as in the preceding tests). This will impart shearing forces which tend to separate the fastener and the cotton strip from each other.

Set the distance between the clamps of the tensile tester so there is excess material (or slack) in the sample. Thus, the sample should not be under tension at this point.

151

Initiate the elongation at a cross head speed of 0.367 inches per second (0.93 cm. per second). If the sample has an adhesive fastener, the elongation should be initiated within 30 seconds after the removal of the 0.25 psi. foam covered weight used to fasten the sample to the cotton strip. Set the trigger point to begin collecting force and elongation data at 50 grams force. The cross head should travel until the cotton separates (i.e., shears) from the 1.0 inch section of the sample's fastener.

The force and extensibility measurements are taken at the desired times, and the test is completed. The gauge length used to calculate % elongation is the linear distance from the free end of the stationary jaw (the jaw that clamps 0.5 inches inward from the end of the absorbent component at the end of the sample opposite the end of the sample adhered to the cotton strip) to the nearest end edge of the cotton fabric when the sample is subjected to 50 grams of tensile force.

The absorbent article is preferably capable of extending at least about 110%, 115%, 120%, 125%, 130%, 140%, etc. of its initial length before it is subjected to a force of an additional 800 or 1,000 grams, or before the forces exerted on the sample cause the fastener to separate from the cotton fabric when tested under the above test (Test Method (C)(2)).

The tests in Test Method C are intended to simulate the conditions under which an absorbent article will stretch when attached to an undergarment.

D. Method to Measure Rate of Return of Absorbent Article Having Elasticity.

The sample used for this test is the entire absorbent article. This test is also only concerned with the measurement of

152

properties of the sample in the longitudinal direction (i.e., parallel to the longitudinal centerline).

Measure the maximum longitudinal extension of the sample at 1,000 grams force using Test Method B above.

The following test is conducted by hand. Remove any adhesive cover strip from the sample. If the sample has an adhesive fastener, eliminate any adhesive tack by dusting the adhesive fastener with talc or corn starch.

Place a ruler with a scale in either 0.1 inch increments or 1 mm. increments on a table.

Grasp one end of the sample with one hand. The end of the sample should be grasped approximately 1 1/2 inches (about 3.8 cm.) from the transverse end edge of the product. The sample should be held so that it is as flat and horizontal across its width as possible.

Hold the sample either over the ruler or next to the ruler with the body surface of the sample facing upward so that the scale on the ruler can be observed throughout the test. The sample should be held so that the portions of the sample approximately 0.5 inches (1.3 cm.) inward from this fixed end of the sample are firmly held even with the beginning of the scale on the ruler throughout the test.

Place a digital stop watch which can record time to the nearest 0.01 second next to the ruler and the sample. Position a video camera over the articles on the table so that the sample can be observed and the elapsed time on the stop watch can be simultaneously observed and recorded to the nearest 0.1 second.

Grasp the other transverse end edge (i.e., the free end) of the sample. The sample should be grasped at an area approximately two inches (about 5 cm.) wide centered about the longitudinal

153

centerline. The sample should be grasped in this area about 0.5 inch (about 1.3 cm.) inward from the end edge of longest absorbent component. (The 0.5 inch distance should not include any portion of the absorbent component in or outboard of a product end seal as described above.)

Turn on the video recorder and the stop watch. Gradually extend the free end of the sample so that the sample extends to its maximum extension at 1,000 grams (measured earlier) or to 120% of its original length, whichever is greater. The extension process should be completed in less than or equal to 30 seconds.

Release the free end of the sample. The timing on the stop watch starts when the free end is released.

Determine the distance the sample recovers toward its original length and the time it takes to recover toward its original length at the desired points by playing back the video tape on a video cassette recorder frame by frame and observing any contraction of the sample.

Calculate the rate of recovery by dividing the distance the sample retracts (converted to centimeters) by the time required to travel the corresponding distance. This completes the test.

The sample in Test Method D can also be clamped into the clamps of a tensile testing machine, and the test performed in a similar manner with one end of the sample being placed in a stationary clamp, and the other in a clamp that is capable of instantaneously releasing that end of the sample at the desired time.

When the absorbent article is subjected to tensile forces to extend said absorbent article along its longitudinal centerline to: (a) its maximum extended length at 1,000 grams, or (b) 120%

154

of its original length, whichever is greater, and said tensile forces are removed, said absorbent article, if extended to its maximum extended length, recovers from (a)(i) its maximum extended length toward its recovered length (a)(ii) a distance of its maximum extended length less 10% its original length, or if extended to 120% of its original length, recovers to 110% of its original length at a rate of recovery of less than or equal to about 20, 30, or 40 cm./second.

While particular embodiments of the present invention have been illustrated and described, it would be obvious to those skilled in the art that various other changes and modifications can be made without departing from the spirit and scope of the invention.

THE EMBODIMENTS OF THE INVENTION IN WHICH AN EXCLUSIVE
PROPERTY OR PRIVILEGE IS CLAIMED ARE DEFINED AS FOLLOWS:

1. A sanitary napkin that is extensible in response to stretching forces, said sanitary napkin having a specific extended dimension at increasing increments of stretching force, wherein said extended dimension of said sanitary napkin and said stretching force can be plotted on a graph with the extended dimension of said sanitary napkin on the x axis and the stretching force on the y axis so that a series of points are formed on the graph for each force, and said series of points forms a curve, and said sanitary napkin comprises:

a structure that provides said sanitary napkin with a force wall wherein said sanitary napkin has an extended dimension at said force wall, and said force wall prevents said sanitary napkin from extending beyond said extended dimension at said force wall without the application of an substantial additional force, wherein said force wall is activated at the force where said graph has an inflection point.

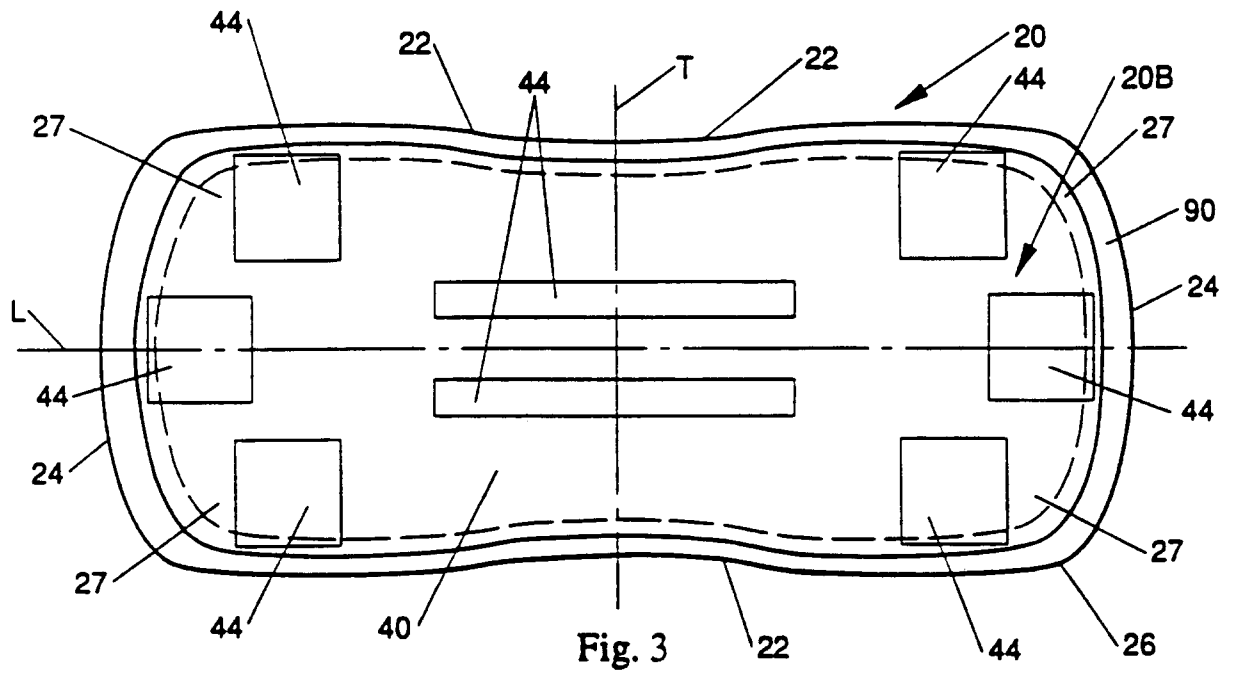
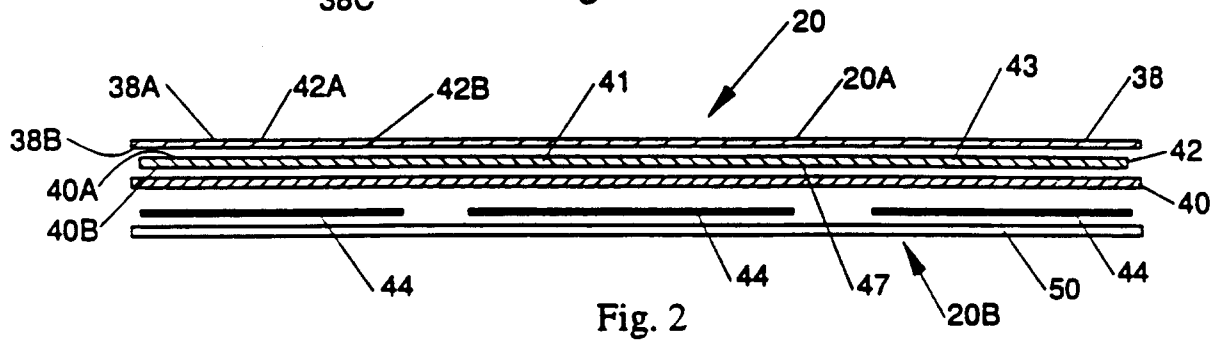
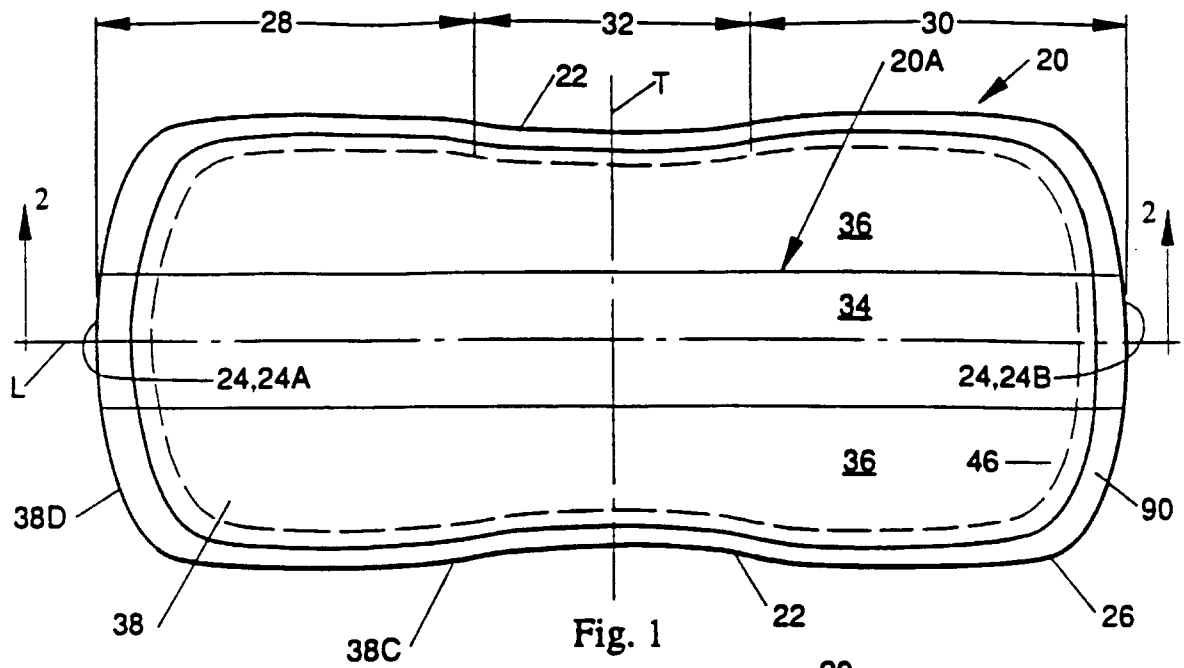

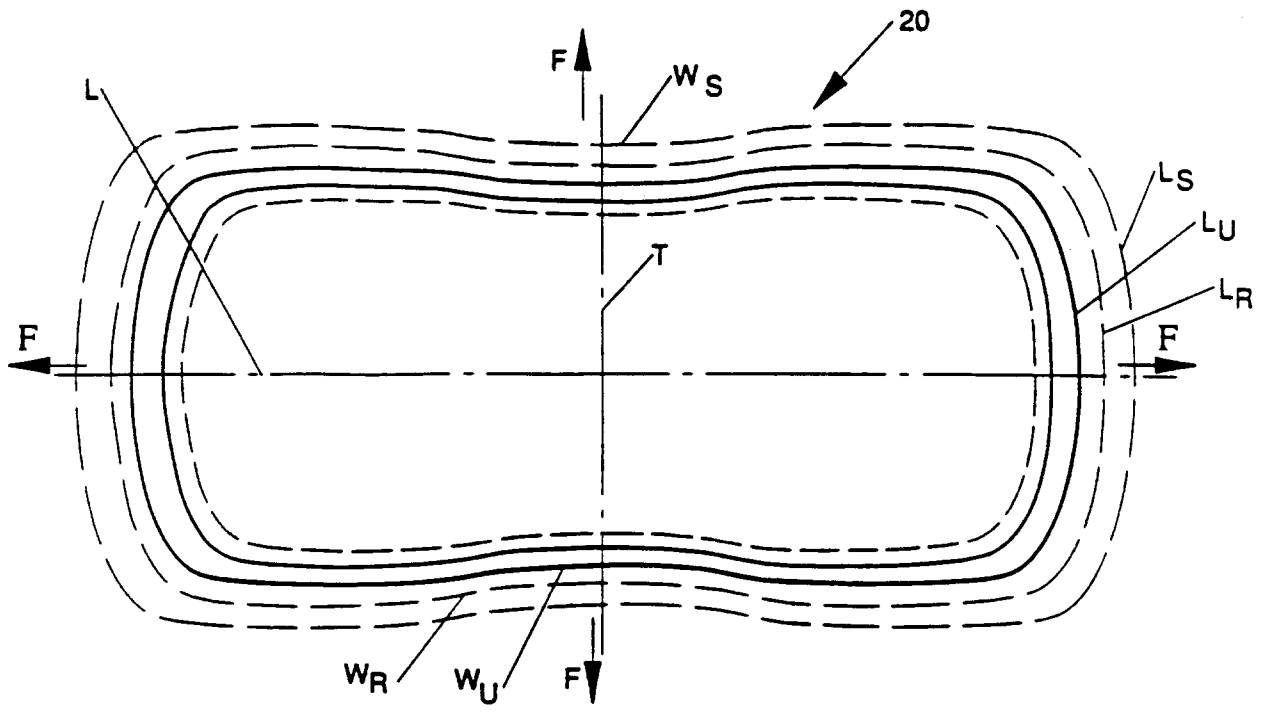

Fig. 4

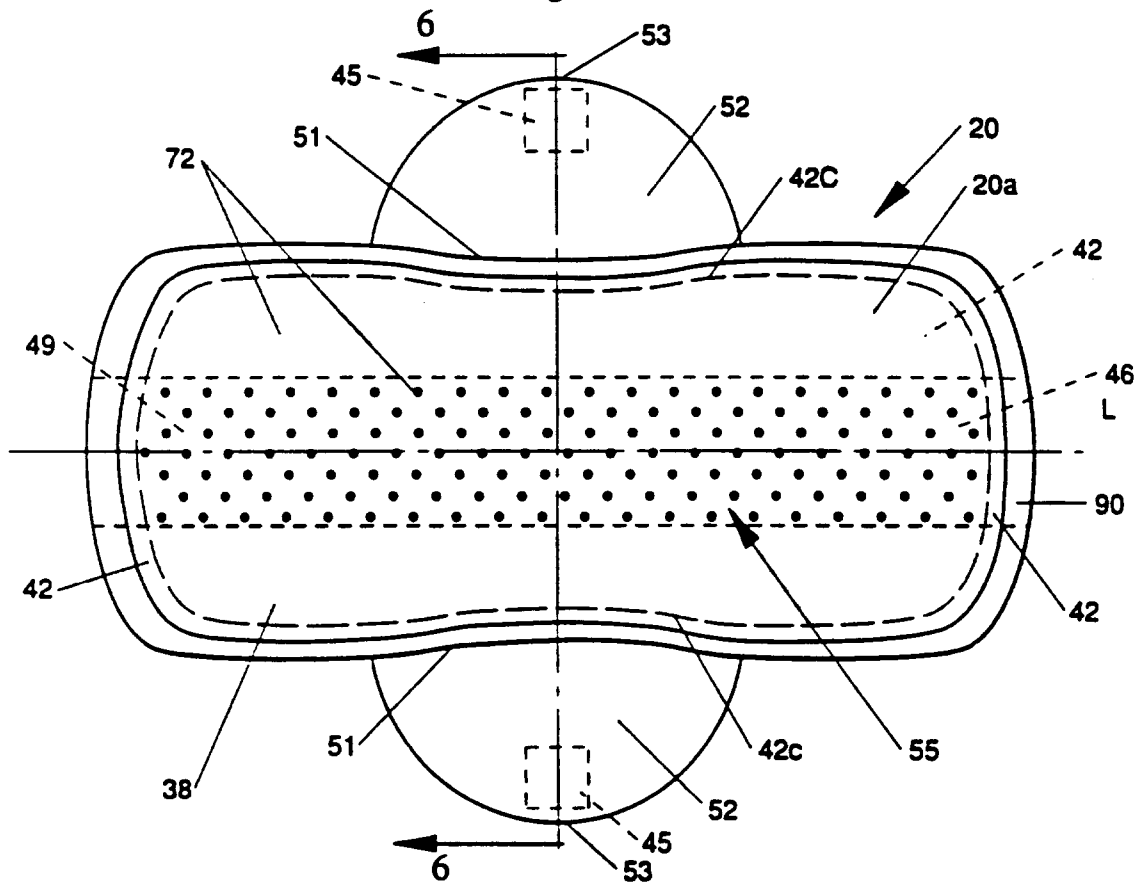

Fig. 5

3/40

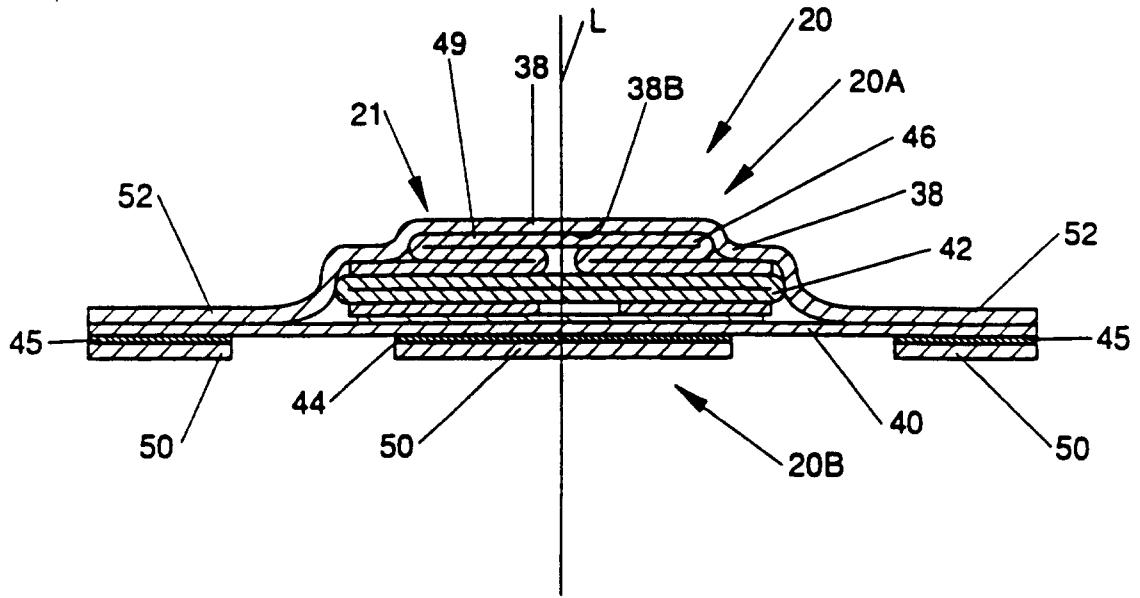

Fig. 6

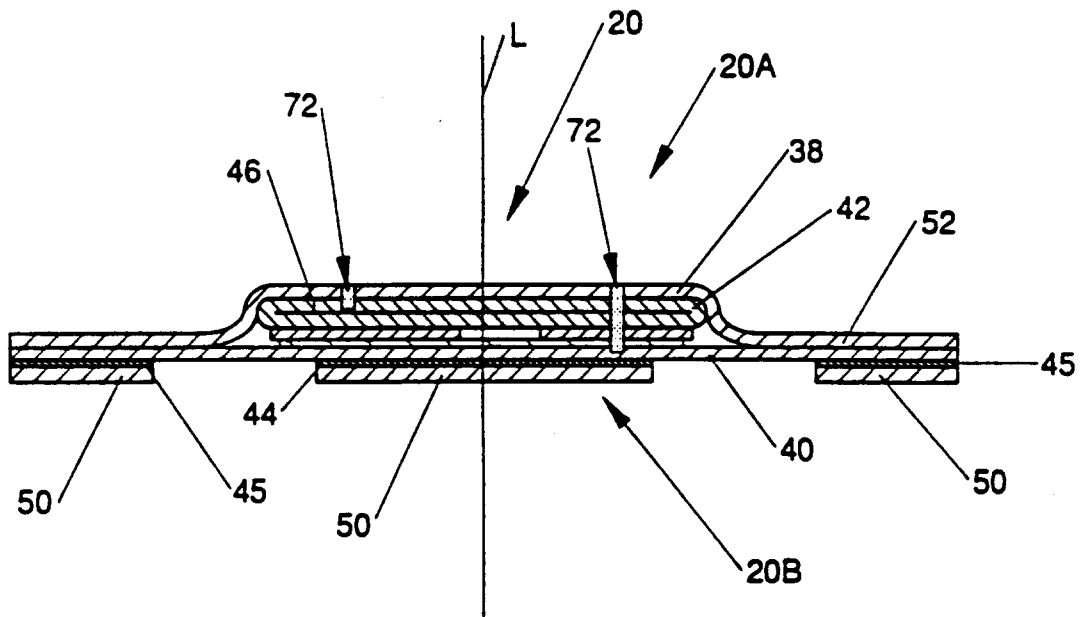

Fig. 7

| | LONGITUDINAL | | | WIDTH | | | ELASTIC WALL | |
|--------------------------|------------------------|---------------------------|-----------|-----------------|----------------------------------|-----------|--------------|--------------------|
| | % LONGITUDINAL STRETCH | g. OF FORCE TO EXTEND PAD | % PAD SET | % WIDTH STRETCH | g. OF FORCE TO EXTEND 1.0" STRIP | % PAD SET | % STRETCH | g. FORCE |
| CONDITIONS FOR STRETCH | 40% | ≤1000 g. | ≤10 | 40% | ≤500 g. | ≤10 | 50% | 1500 g. |
| | | ≤800 g. | ≤10 | | ≤400 g. | ≤25 | | 2000 g. |
| | | | ≤25 | | | | | |
| | 25% | ≤800 g. | ≤10 | 25% | ≤500 g. | ≤10 | 40% | 1500 g. |
| | | ≤400 g. | ≤25 | | ≤400 g. | ≤25 | | 2000 g. |
| | | ≤300 g. | | | | | | |
| MINIMUM FORCE TO STRETCH | 25% | ≥50 g. | | | | | 25% | 1500 g. 2000 g. |

Table 1...Typical Values for Stretch Parameters

Fig. 8

5/40

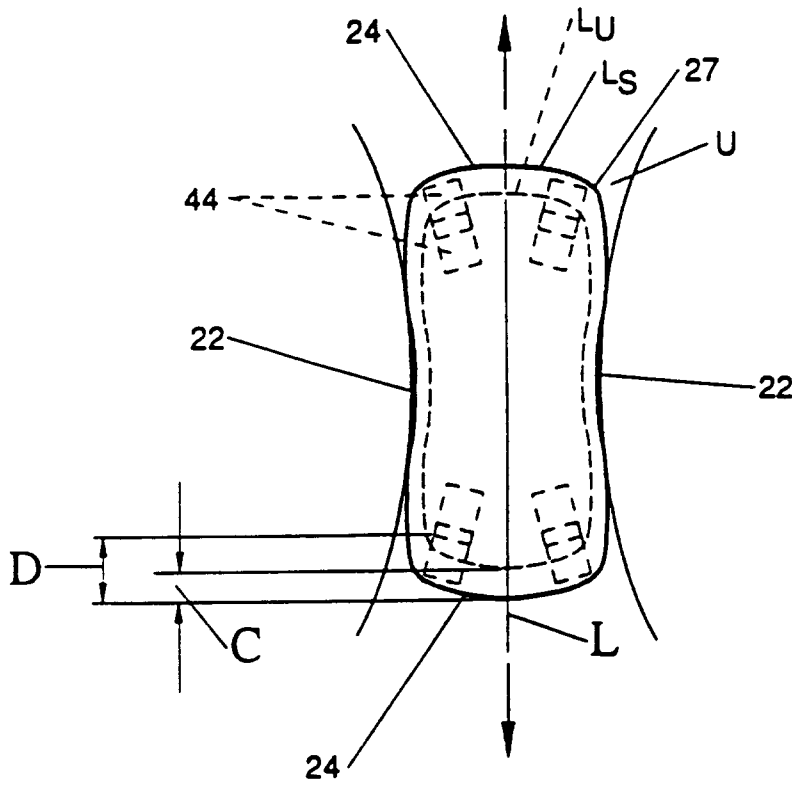

Fig. 8A

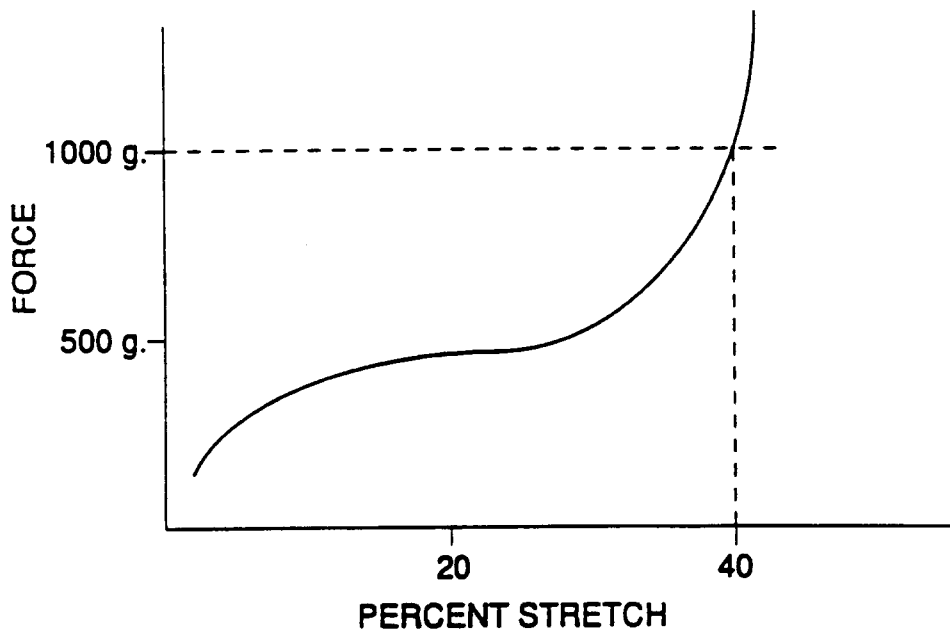

Fig. 9

SUBSTITUTE SHEET

6/40

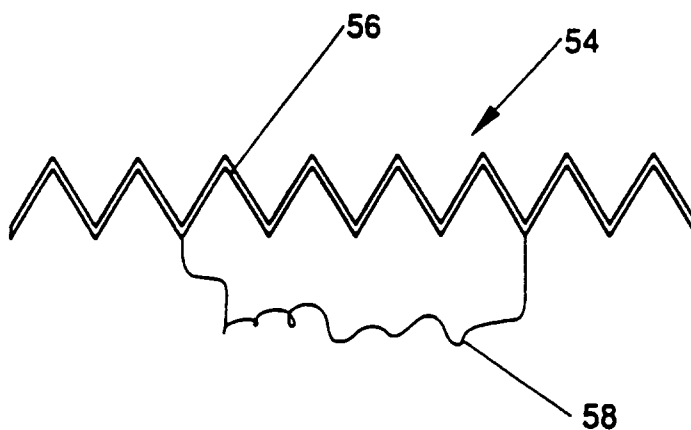

Fig. 10

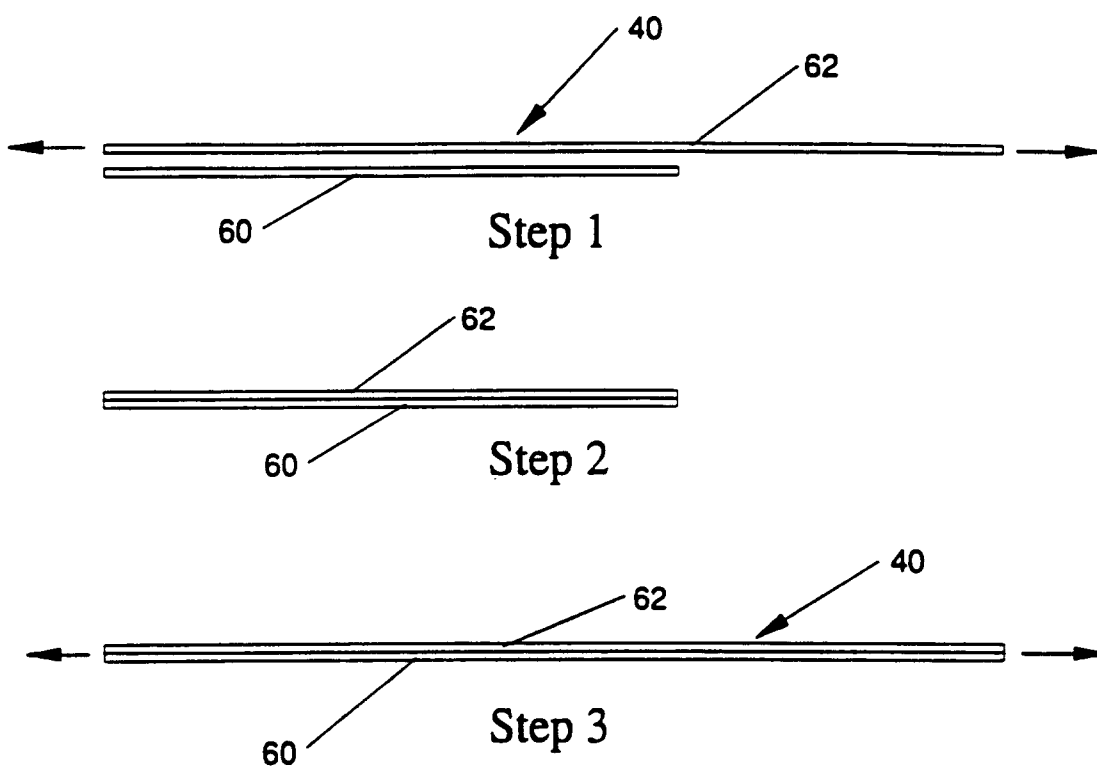

Fig. 11

7/40

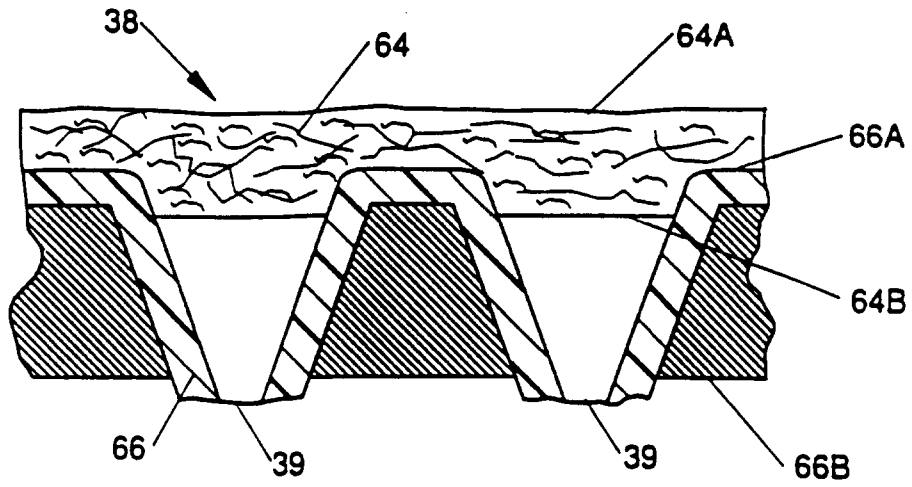

Fig. 12

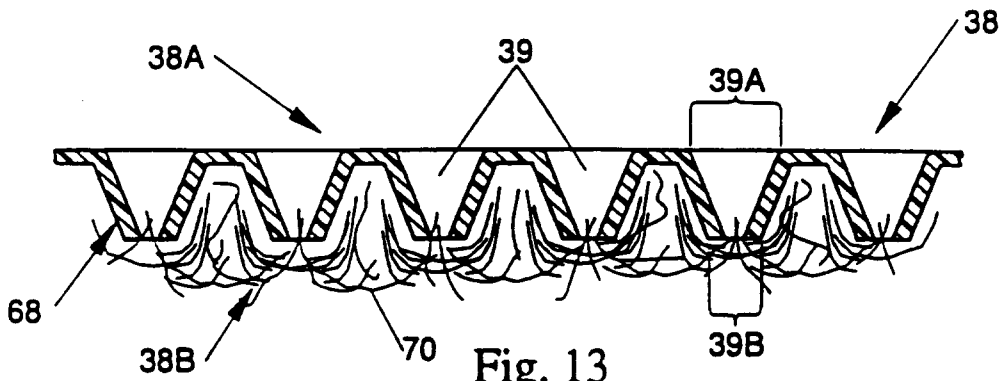

Fig. 13

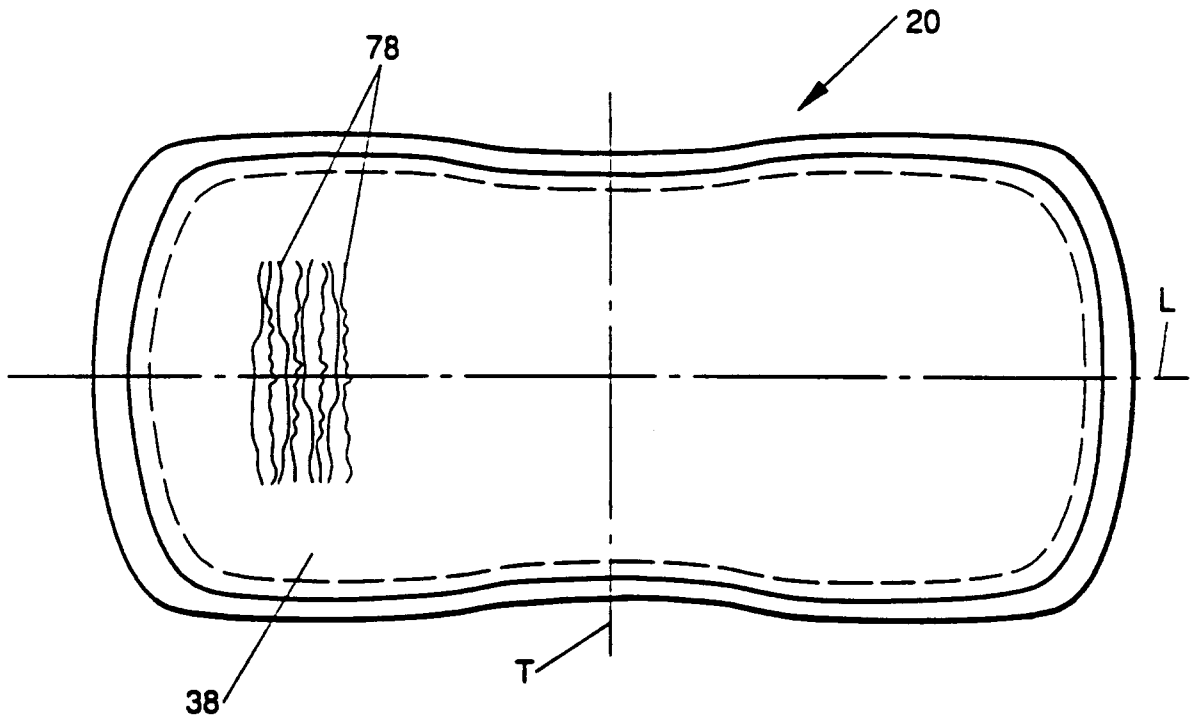

Fig. 14

8/40

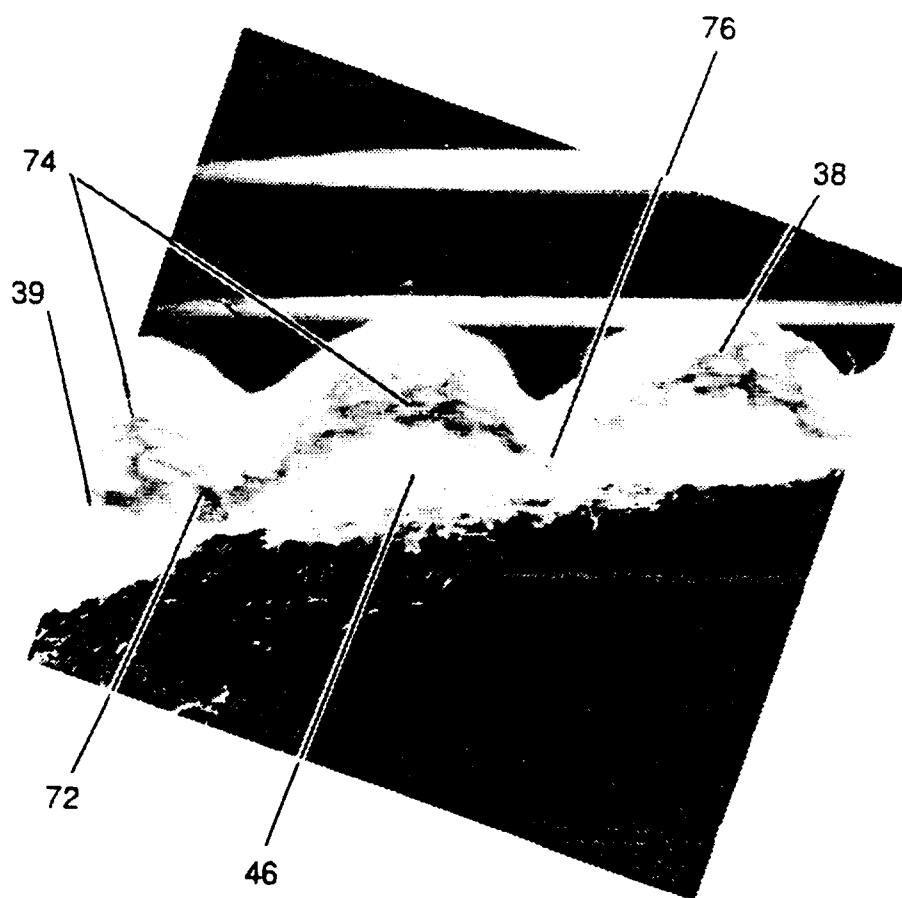

Fig. 15

9/40

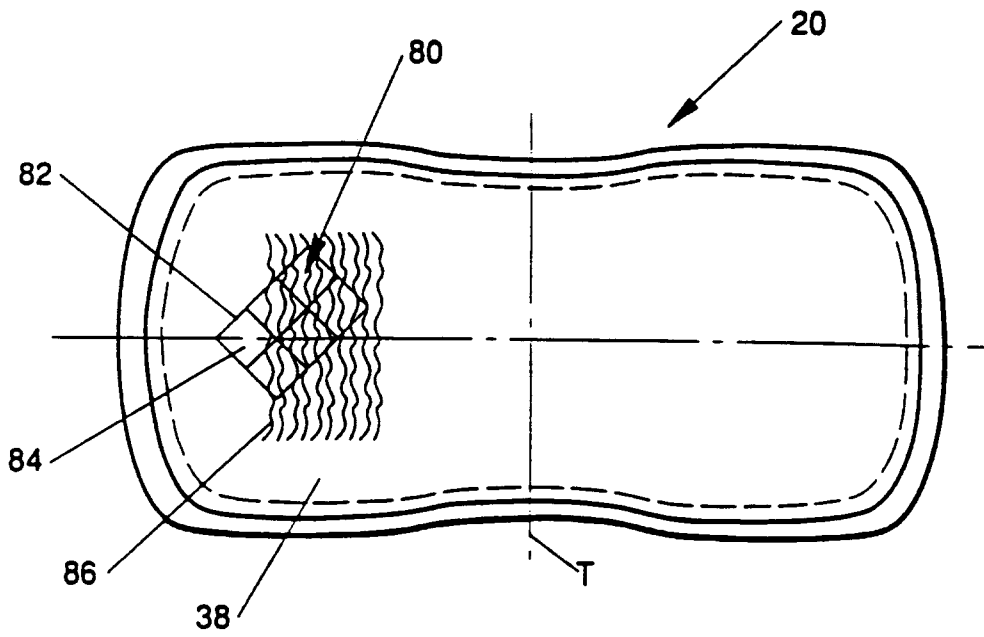

Fig. 16

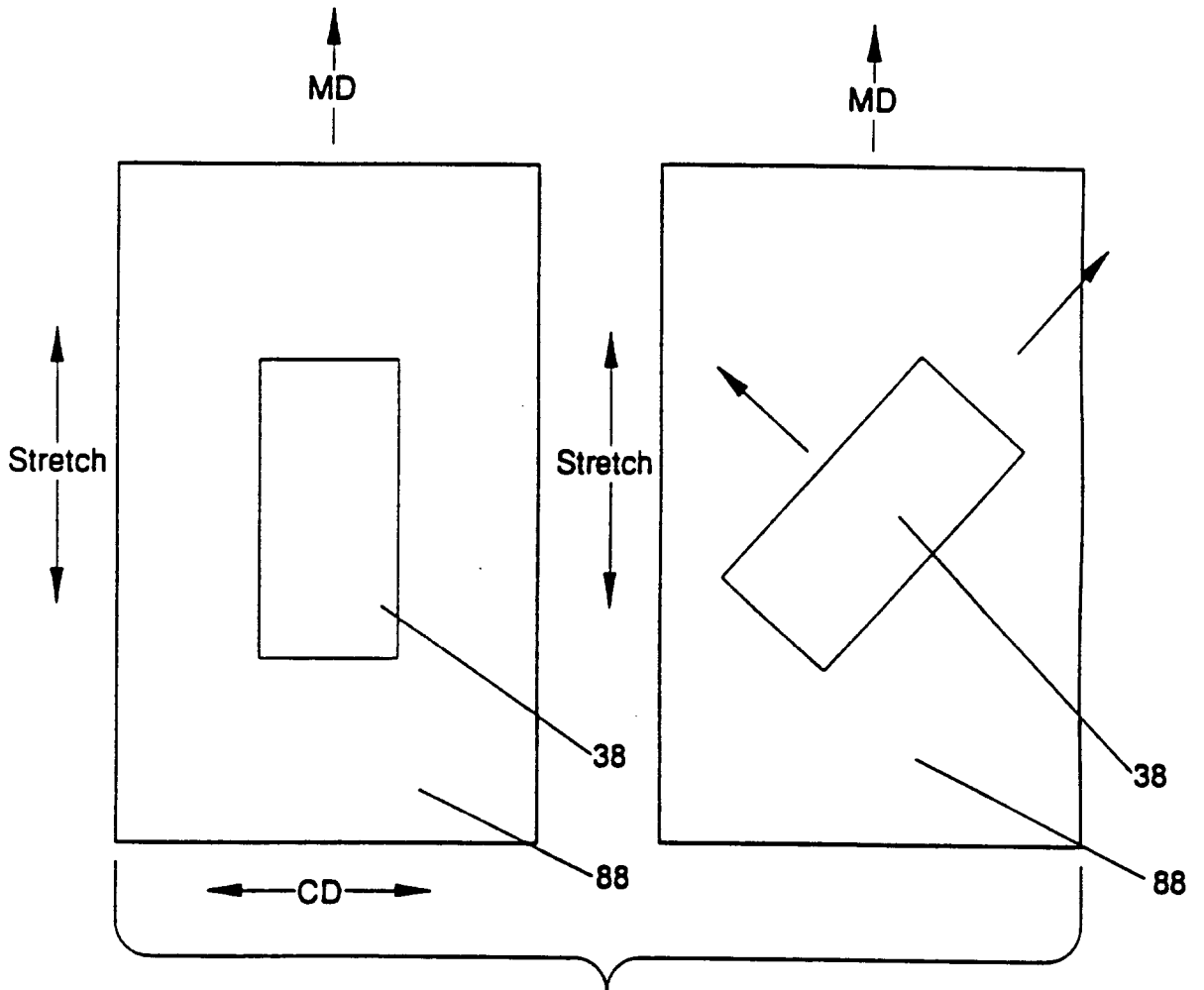

Fig. 17

SUBSTITUTE SHEET

10/40

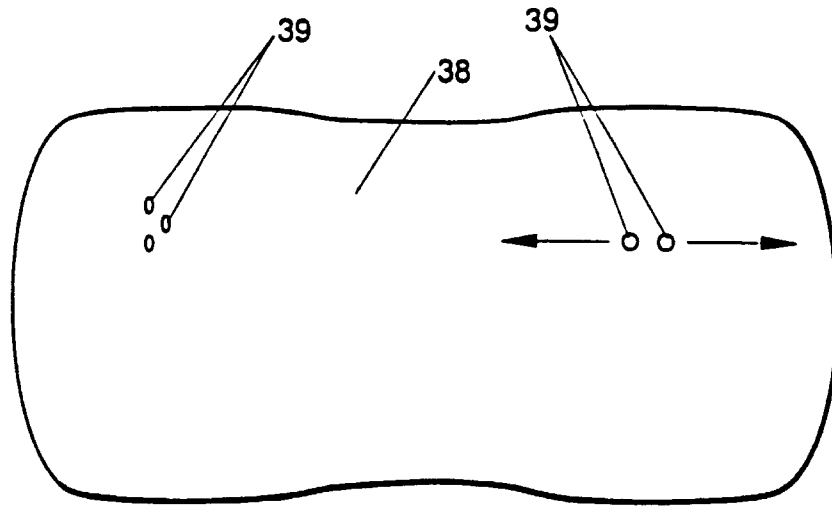

Fig. 17A

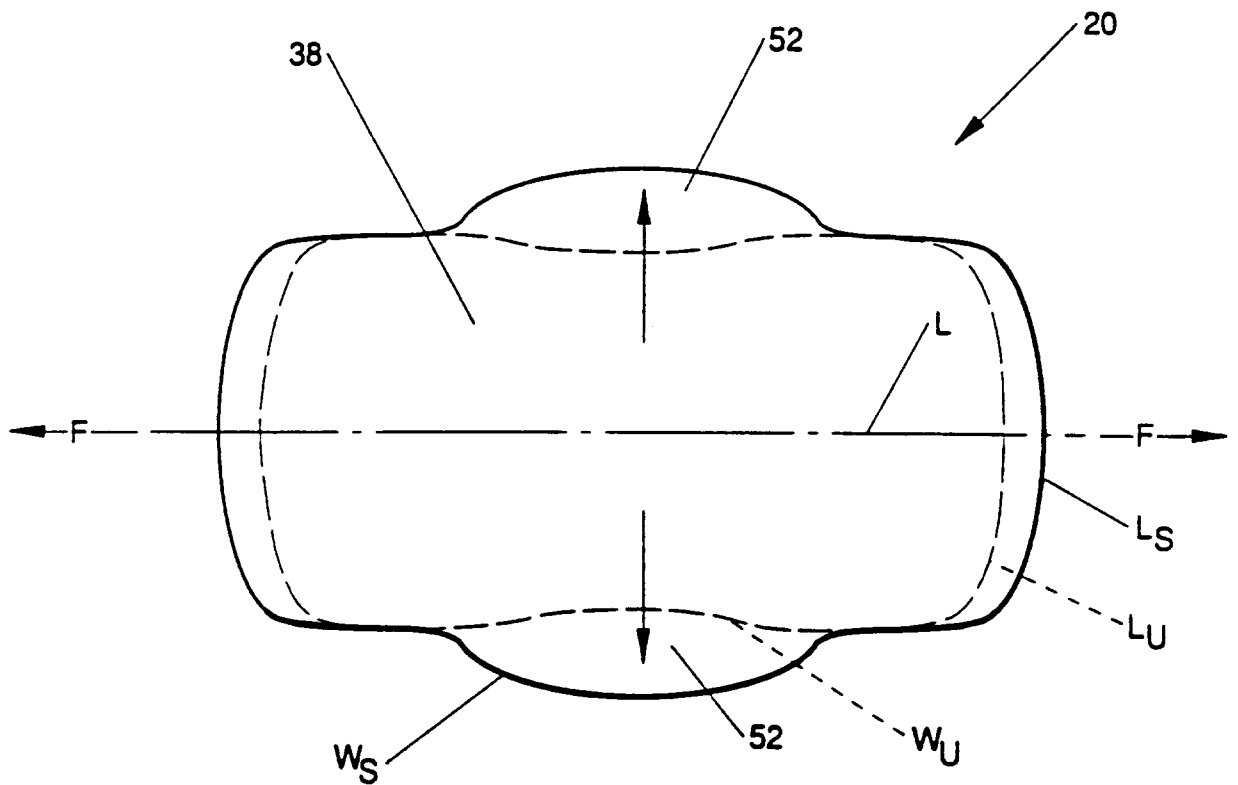

Fig. 17B

11/40

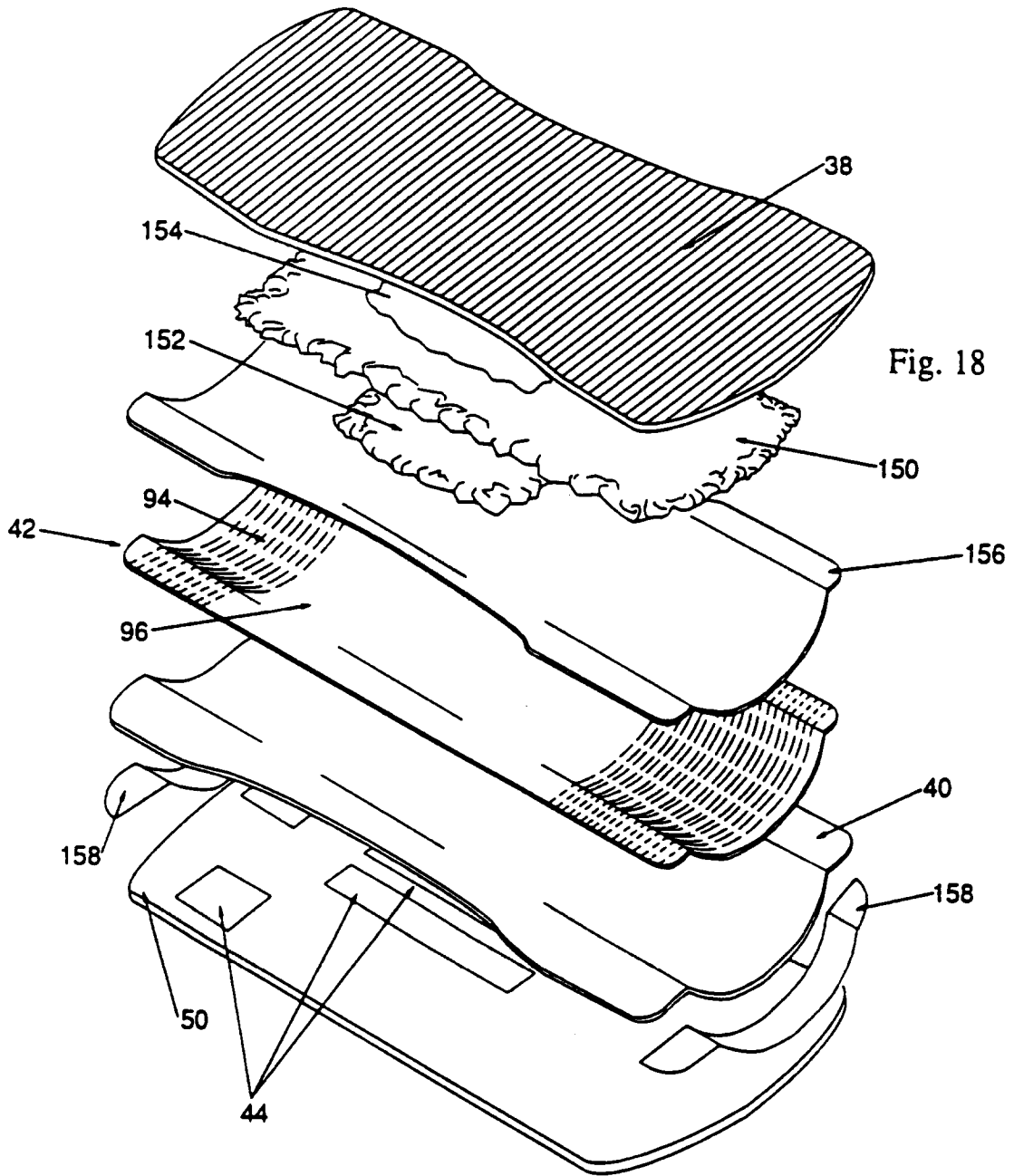

Fig. 18

SUBSTITUTE SHEET

12/40

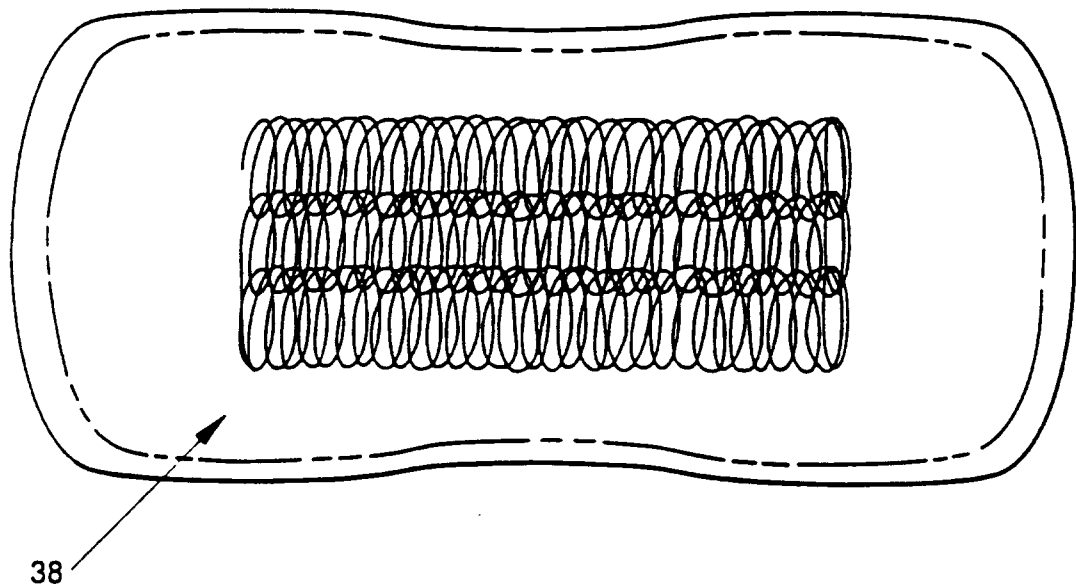

Fig. 18A

13/40

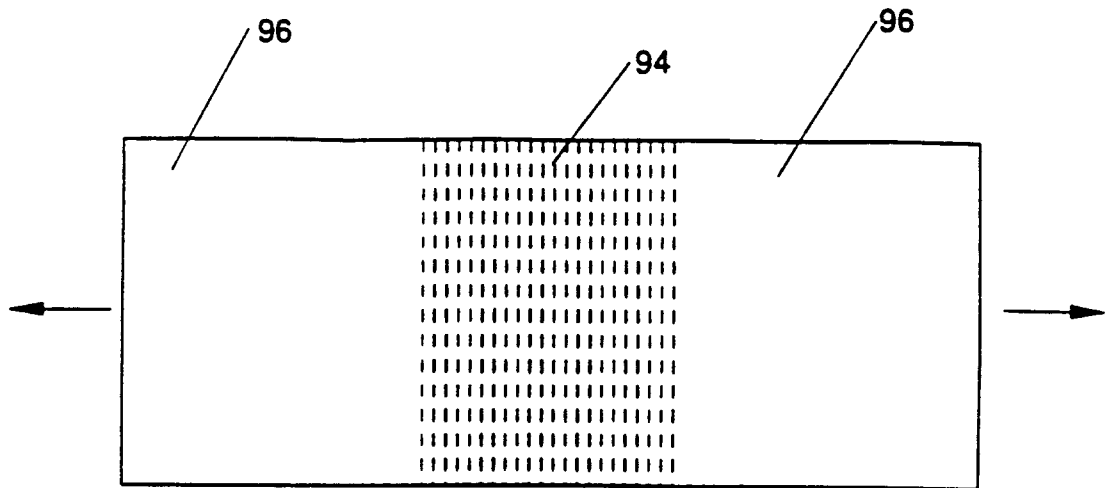

Fig. 19

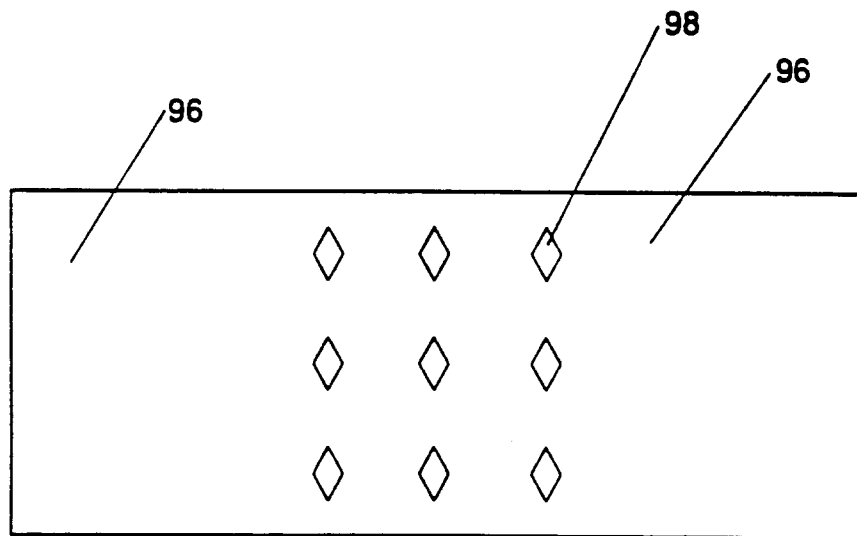

Fig. 20

SUBSTITUTE SHEET

14/40

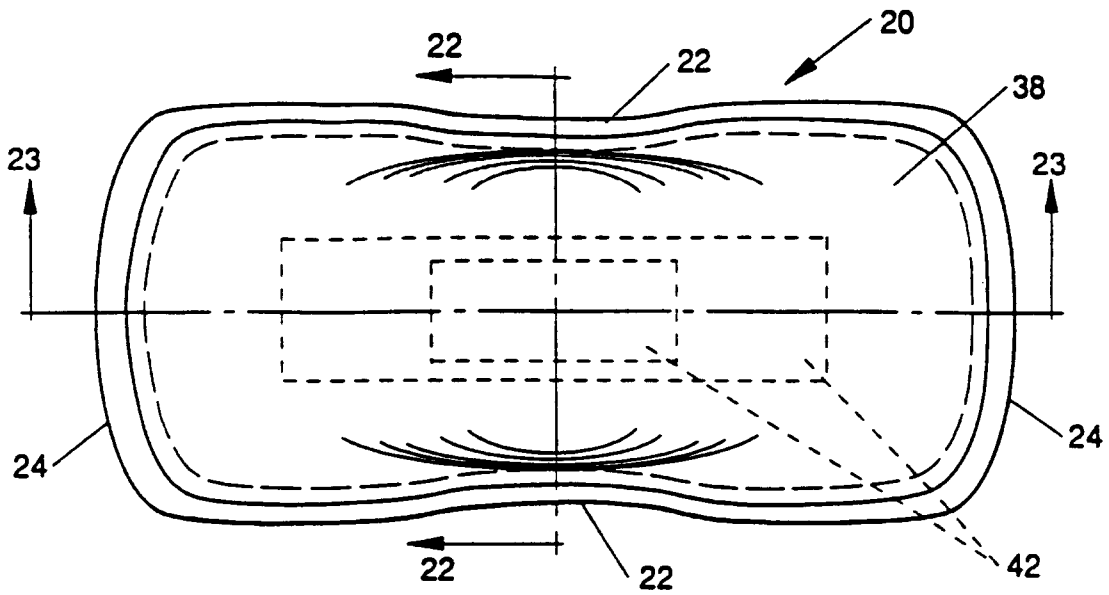

Fig. 21

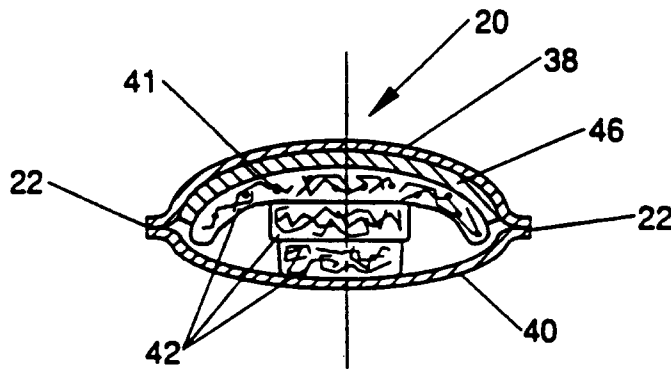

Fig. 22

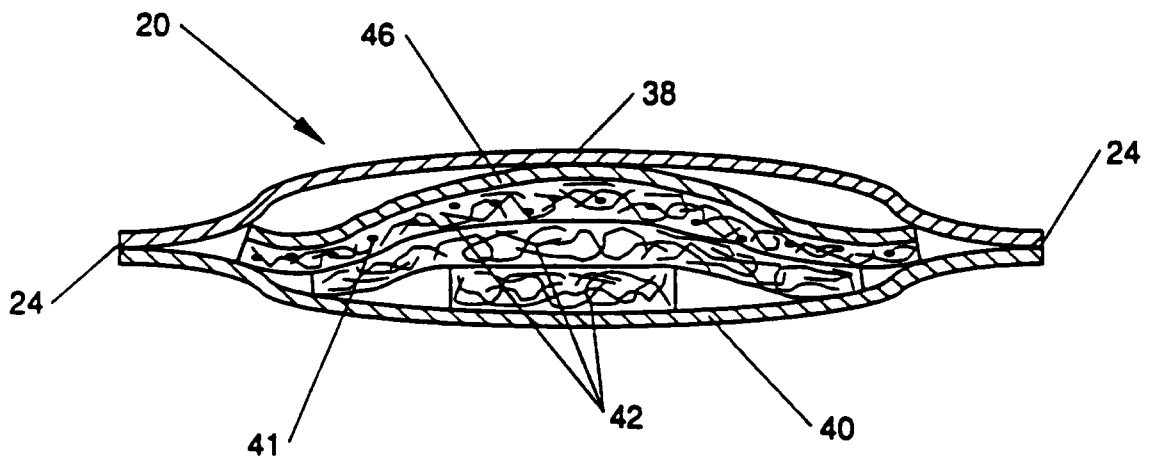

Fig. 23

15/40

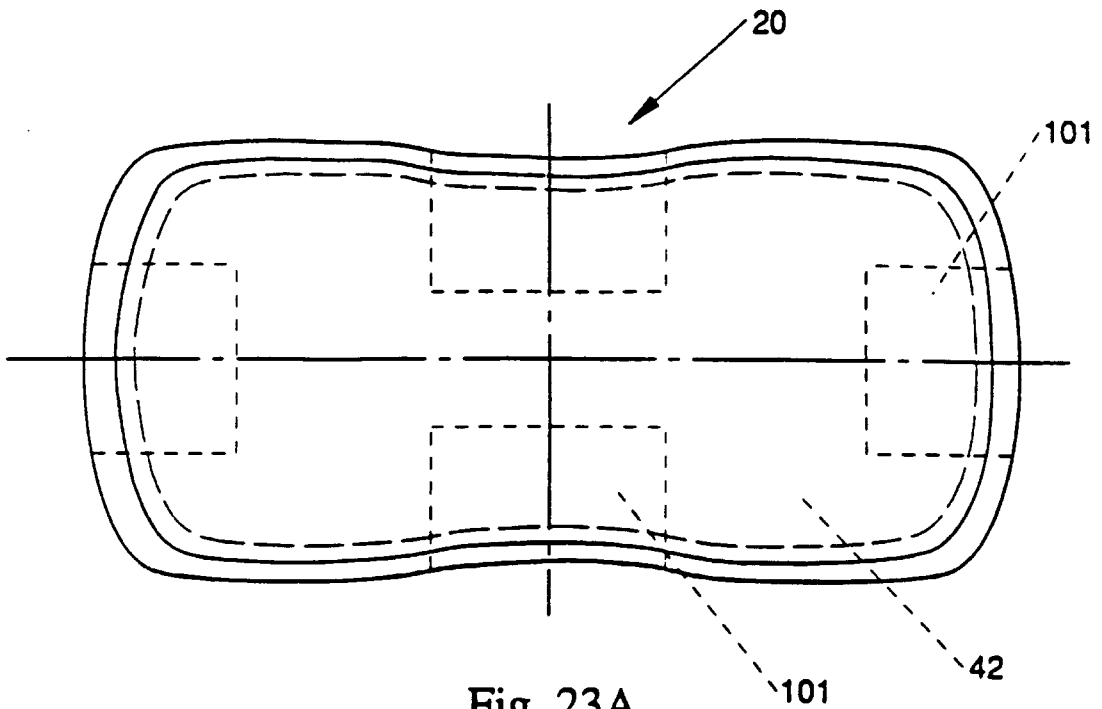

Fig. 23A

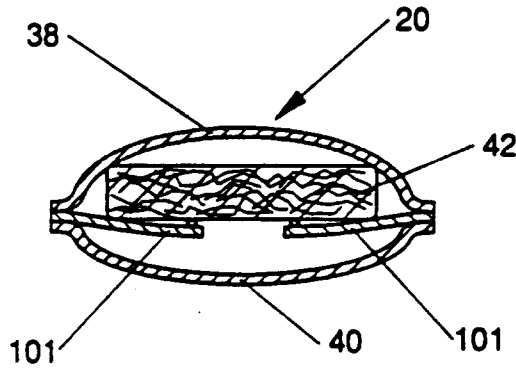

Fig. 23B

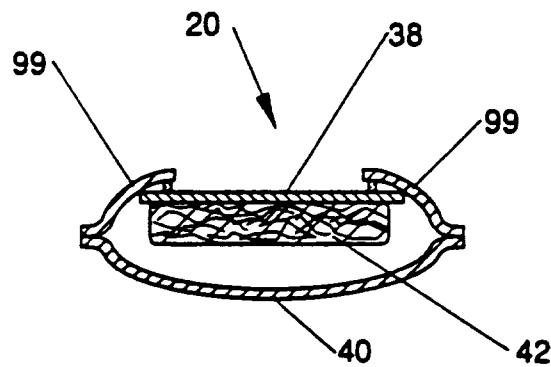

Fig. 23C

16/40

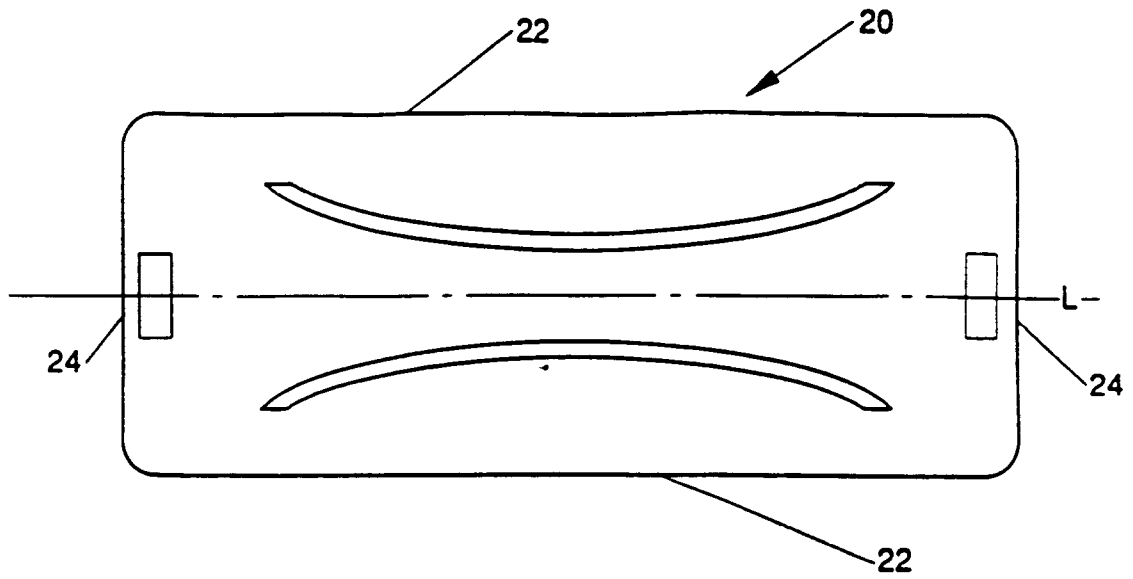

Fig. 24

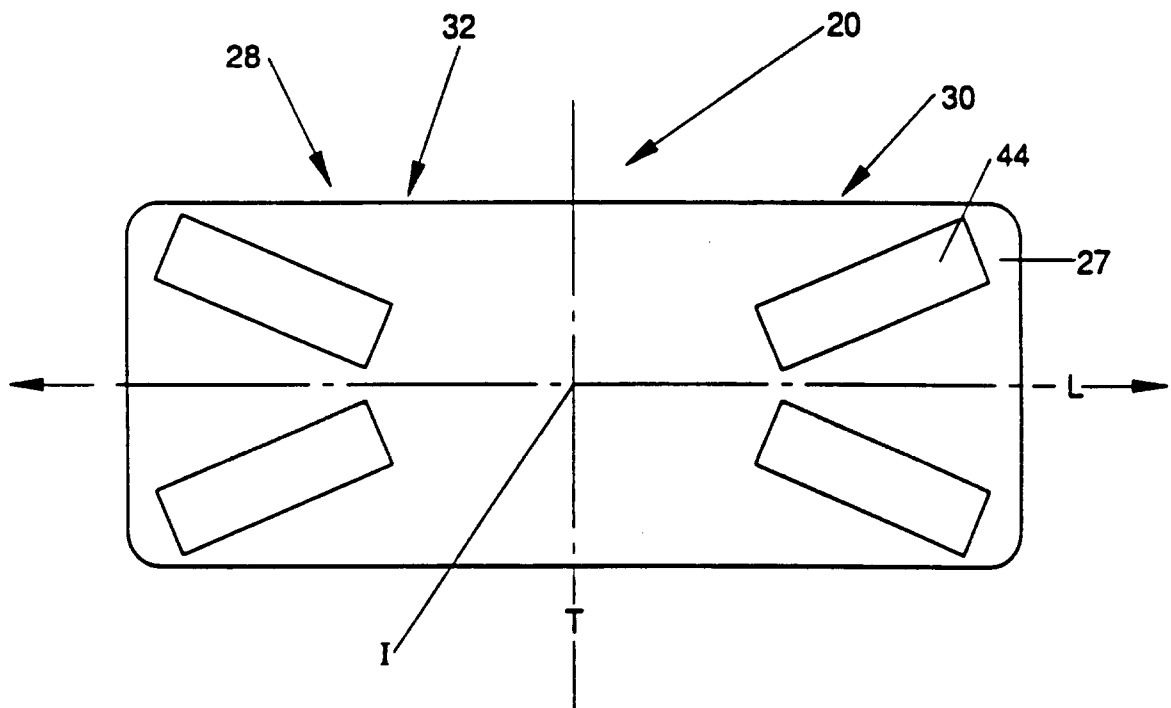
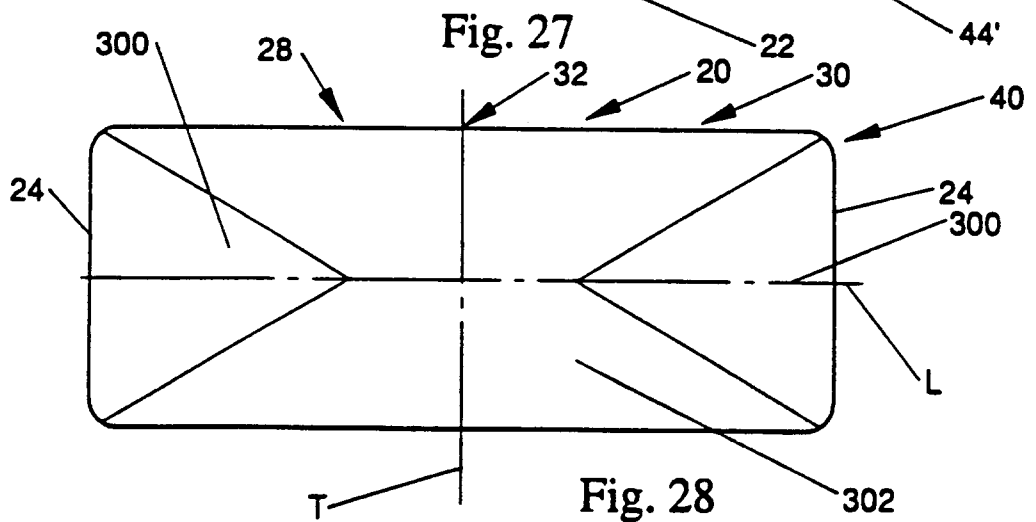
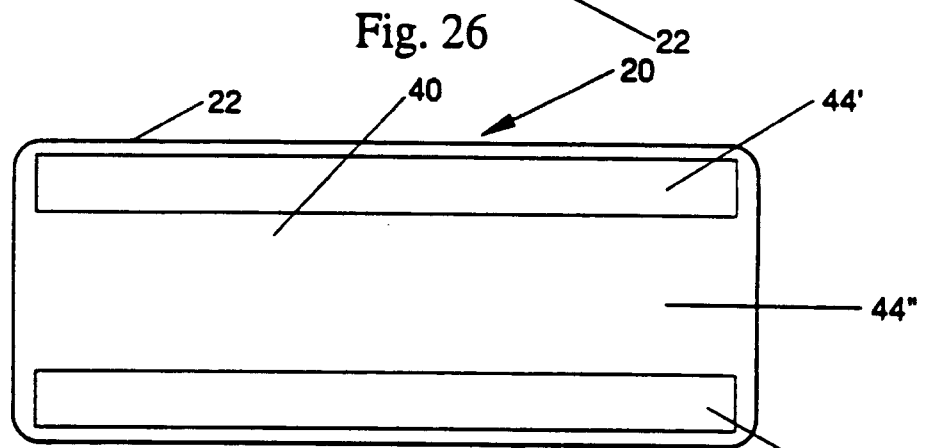
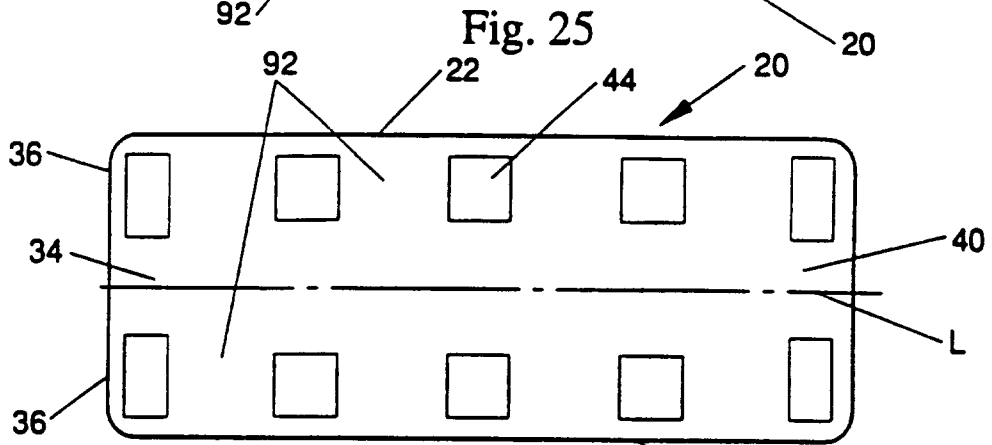
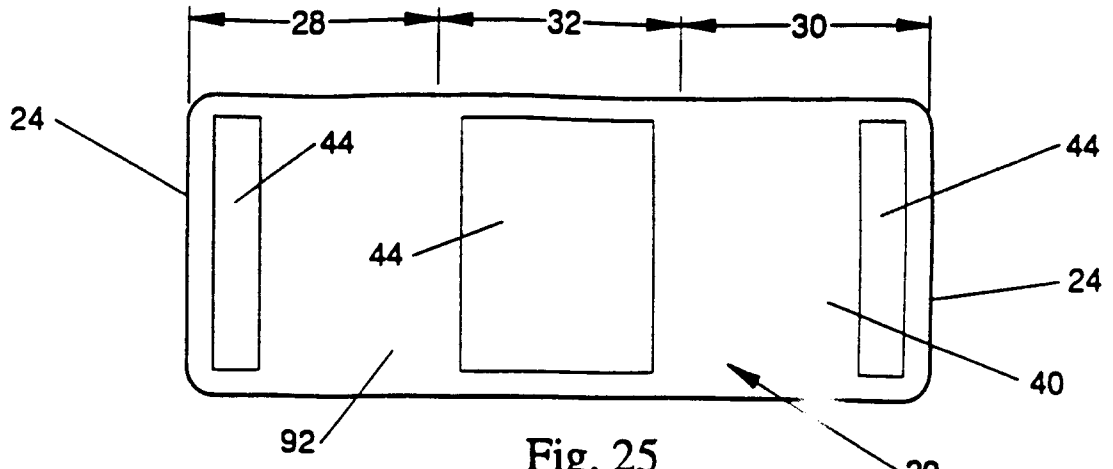

Fig. 26A



18/40

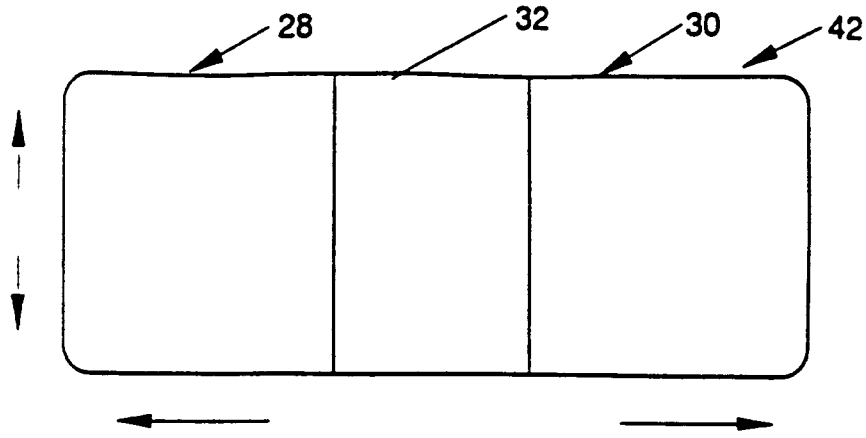

Fig. 29

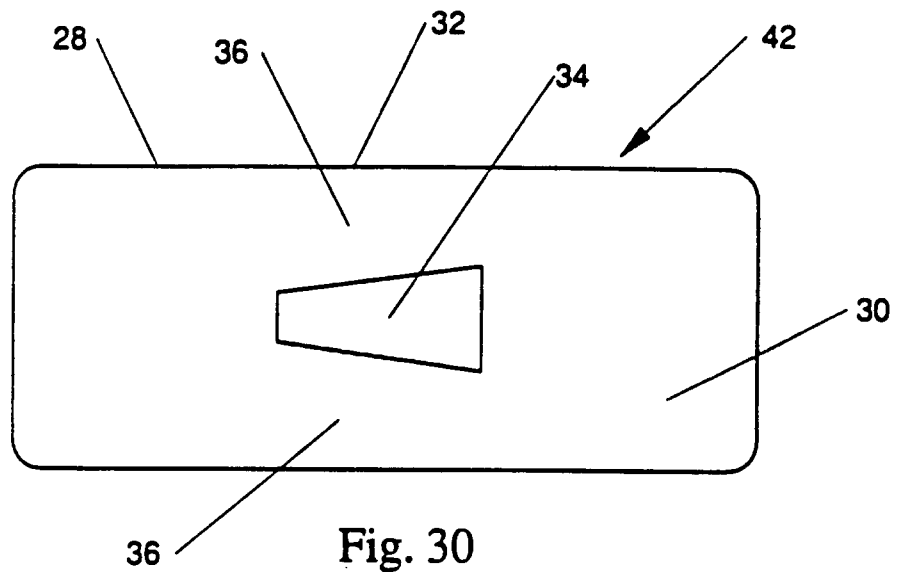

Fig. 30

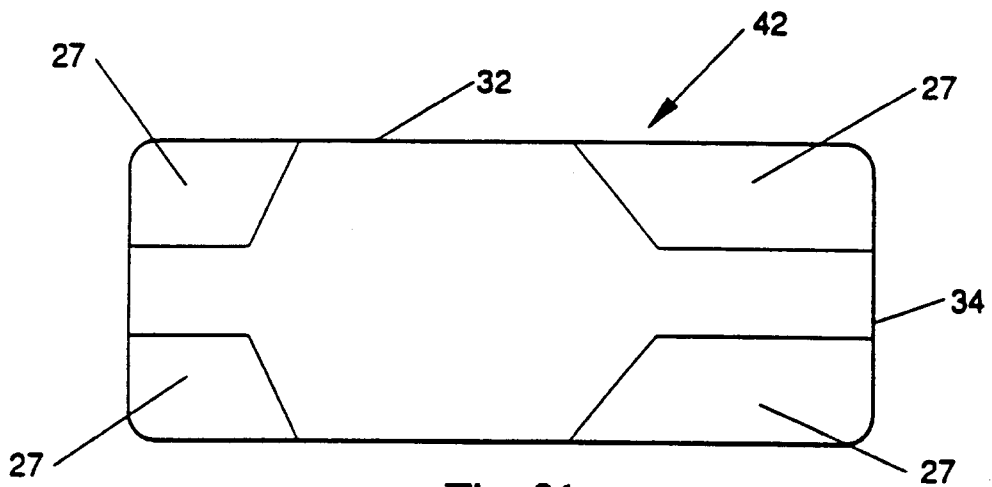

Fig. 31

19/40

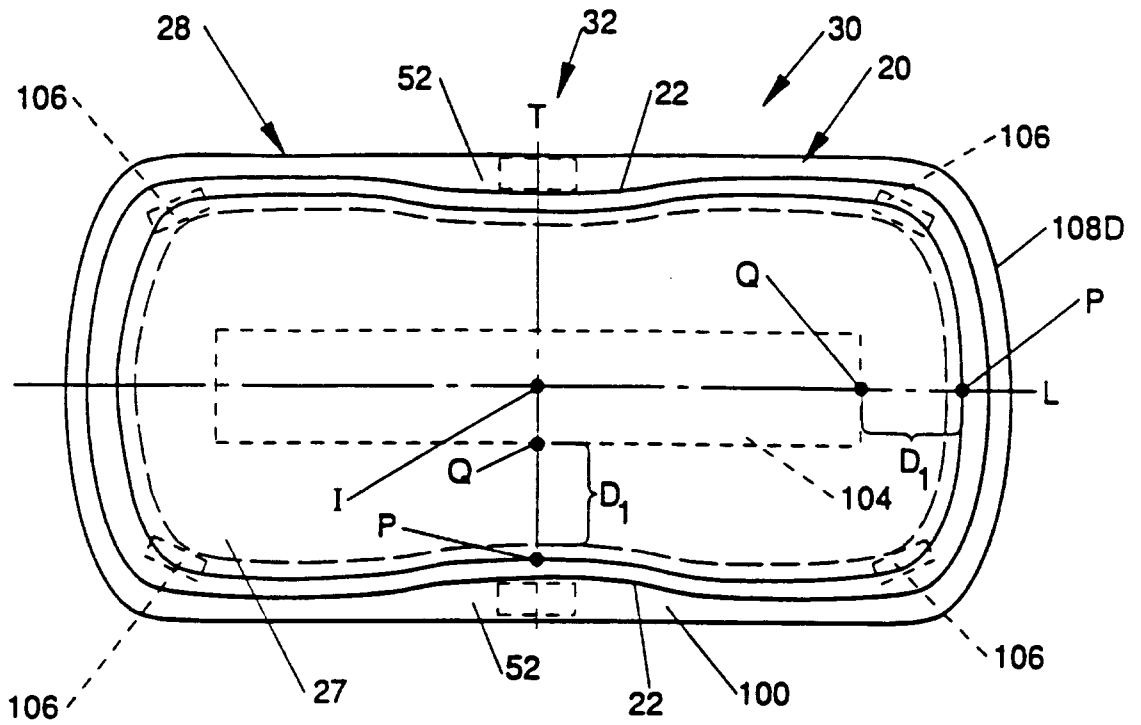

Fig. 32

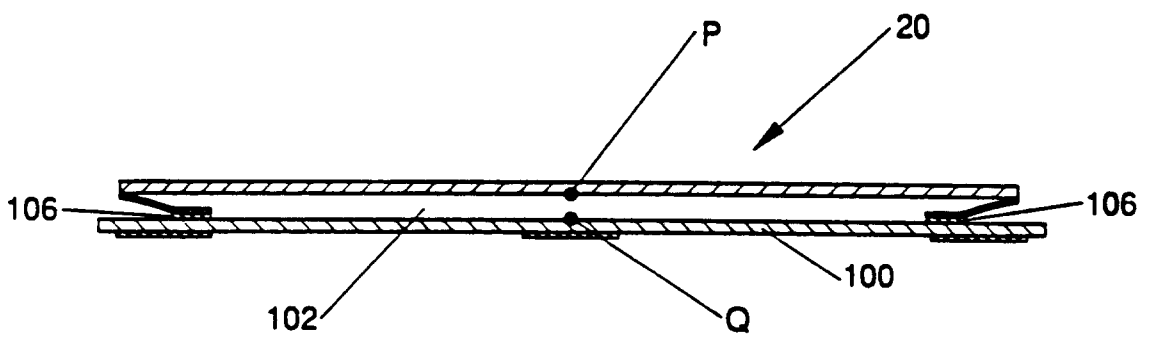

Fig. 33

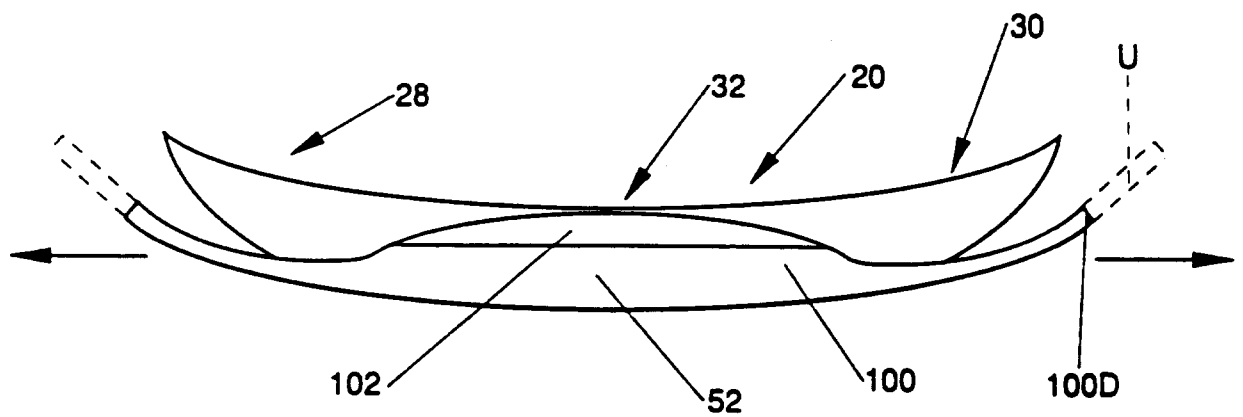

Fig. 34

SUBSTITUTE SHEET

20/40

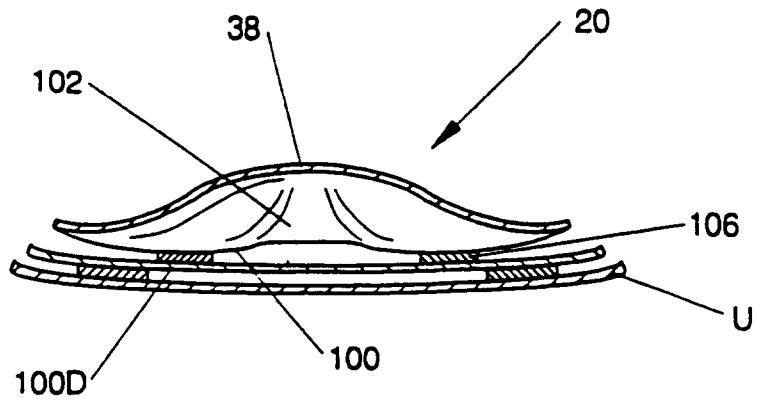

Fig. 35

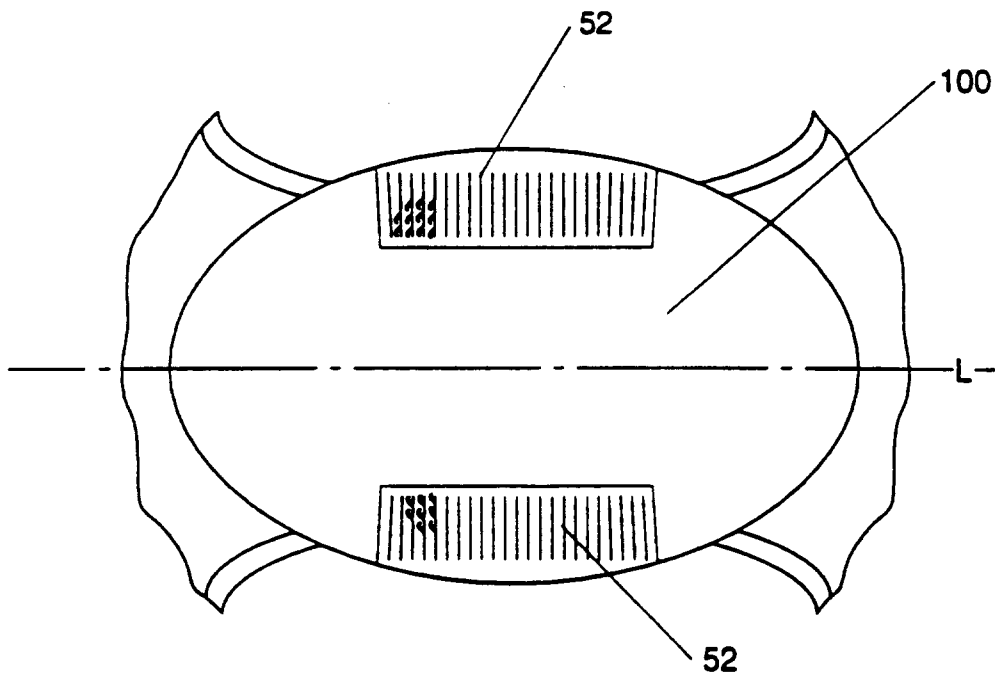

Fig. 35A

21/40

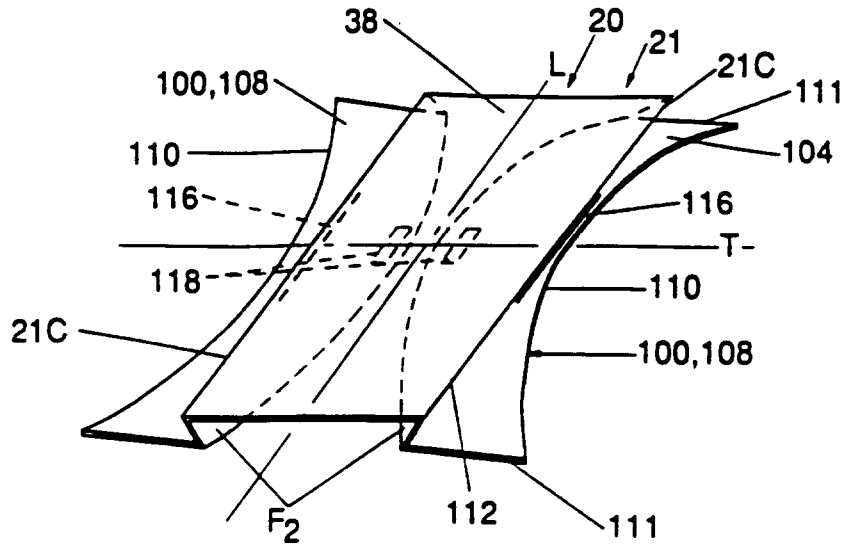

Fig. 36

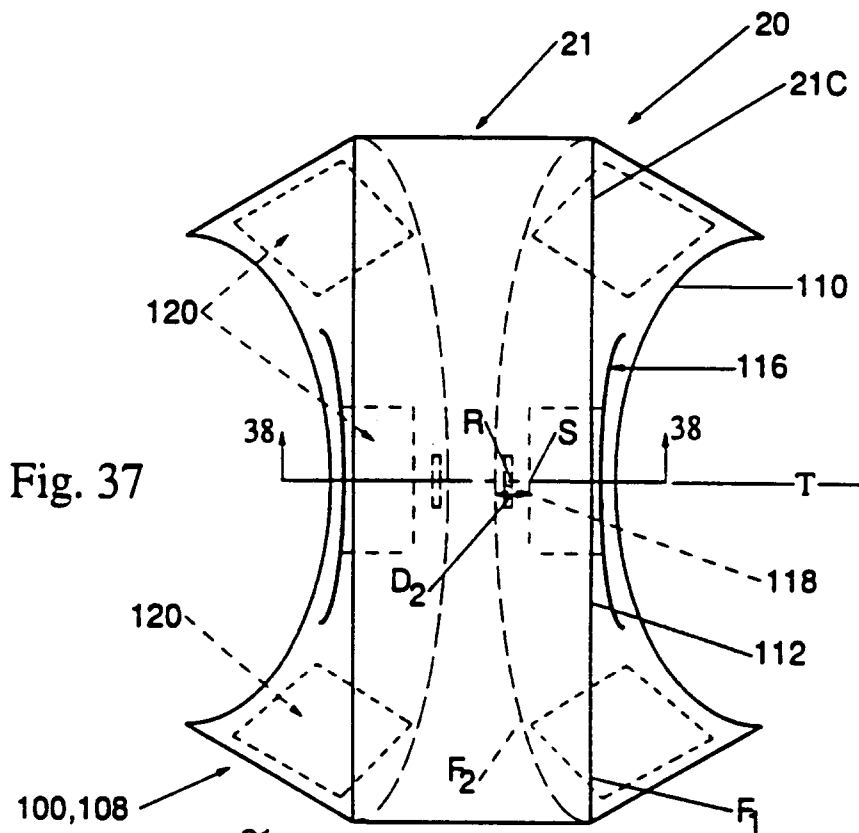

Fig. 37

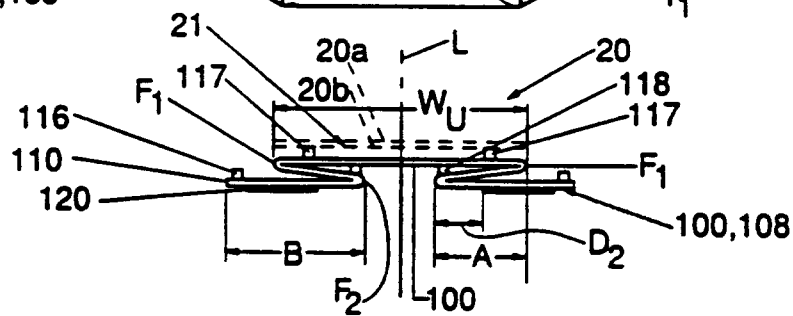

Fig. 38

SUBSTITUTE SHEET

22/40

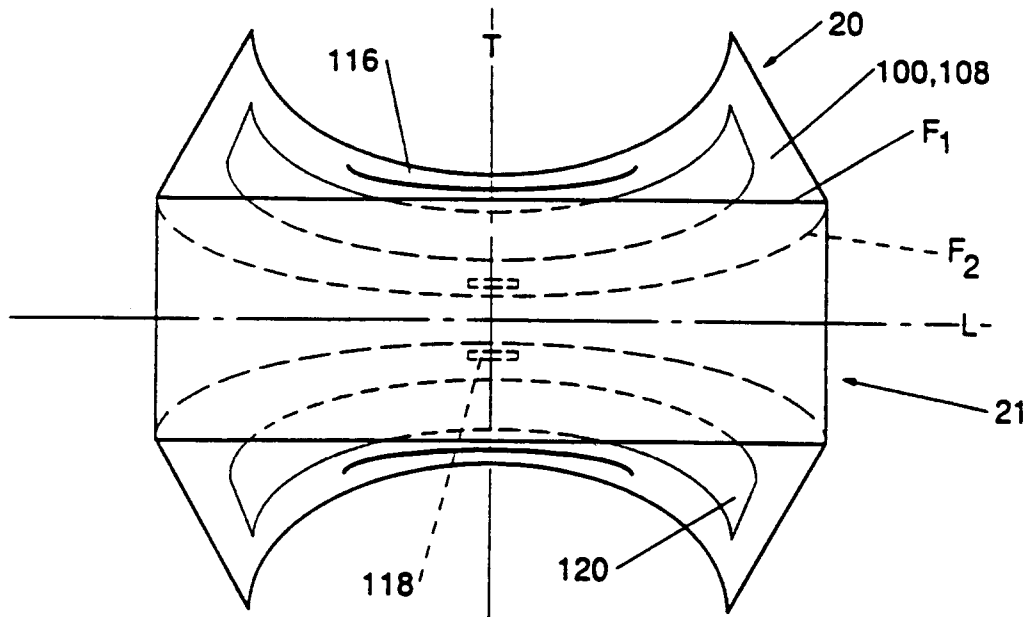

Fig. 39

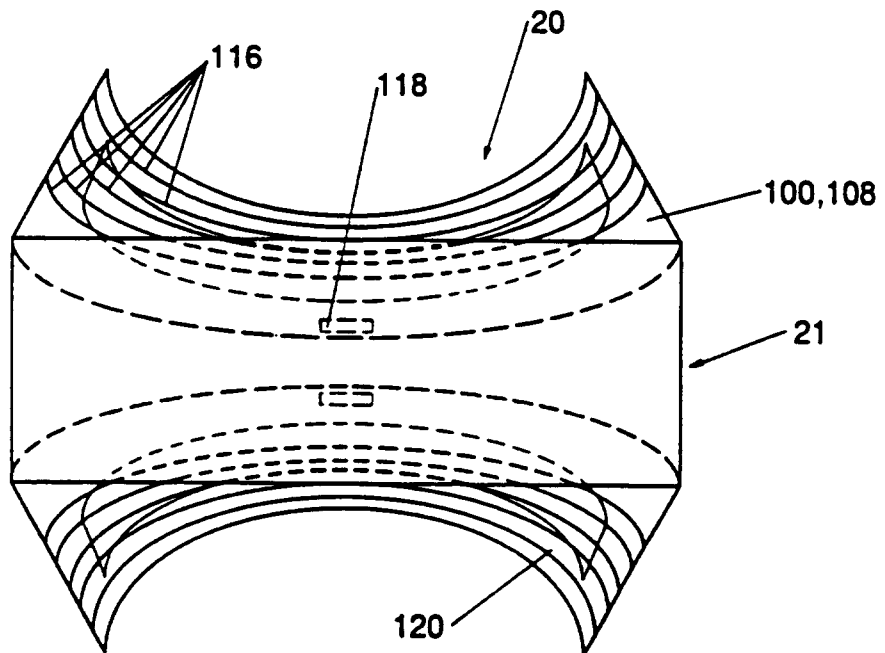

Fig. 40

23/40

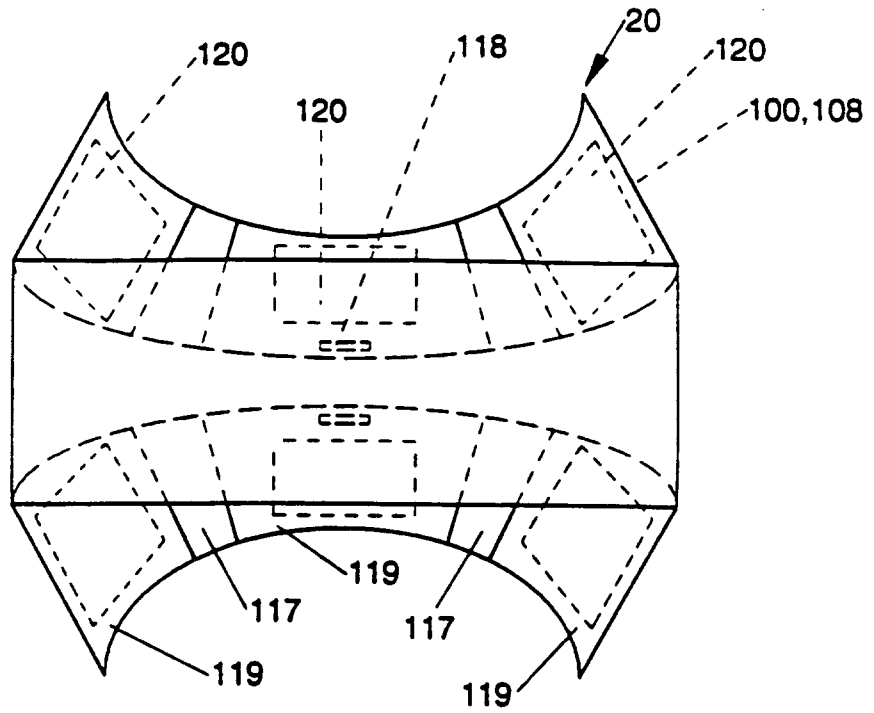

Fig. 41

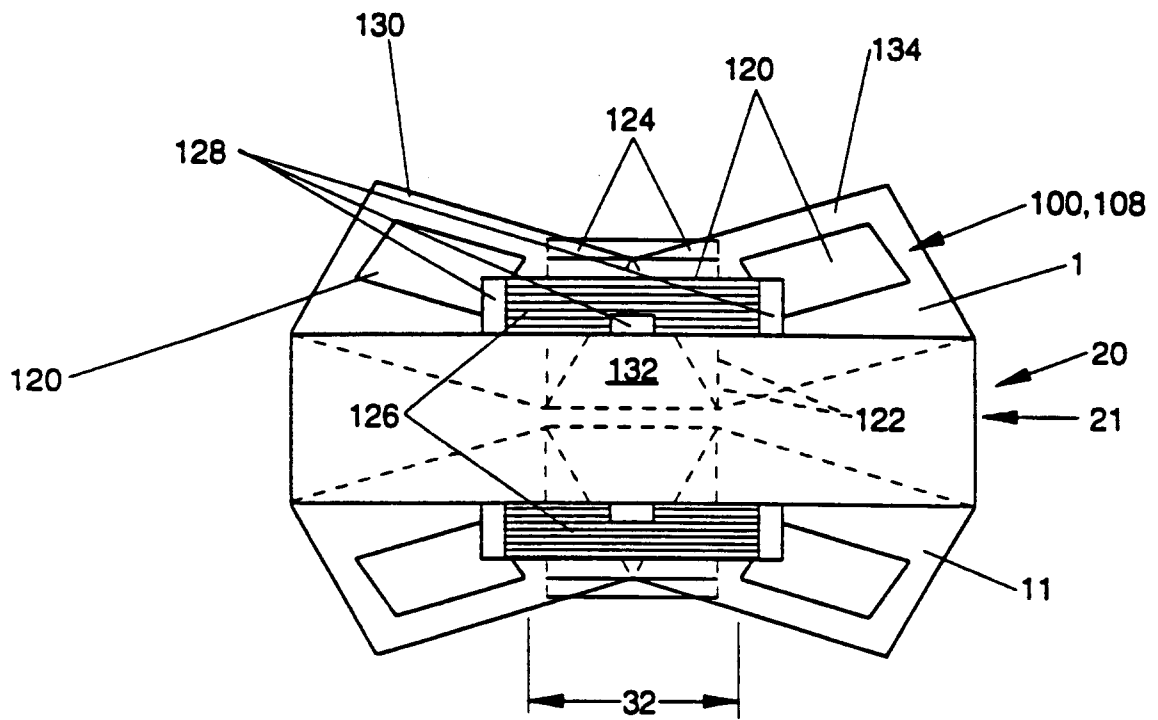
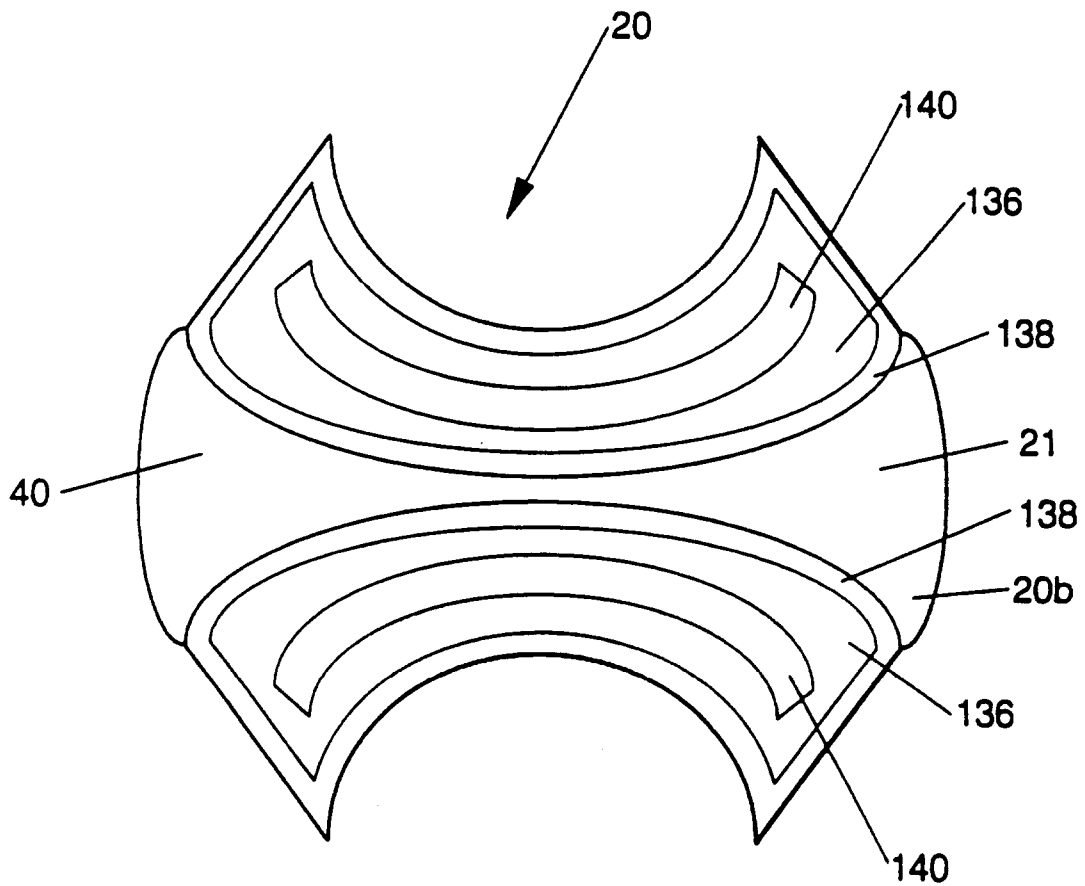
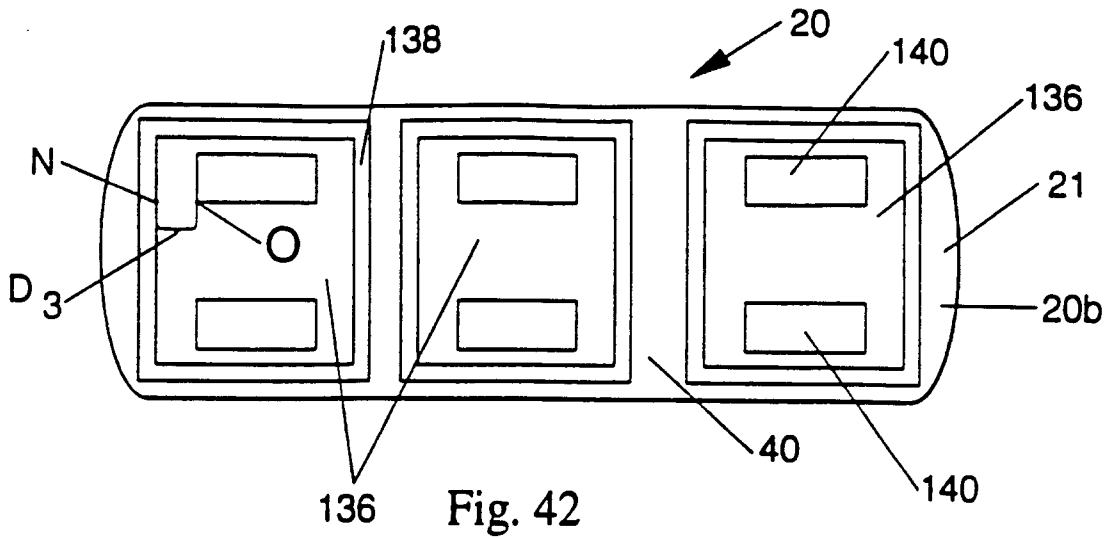

Fig. 41A

24/40



25/40

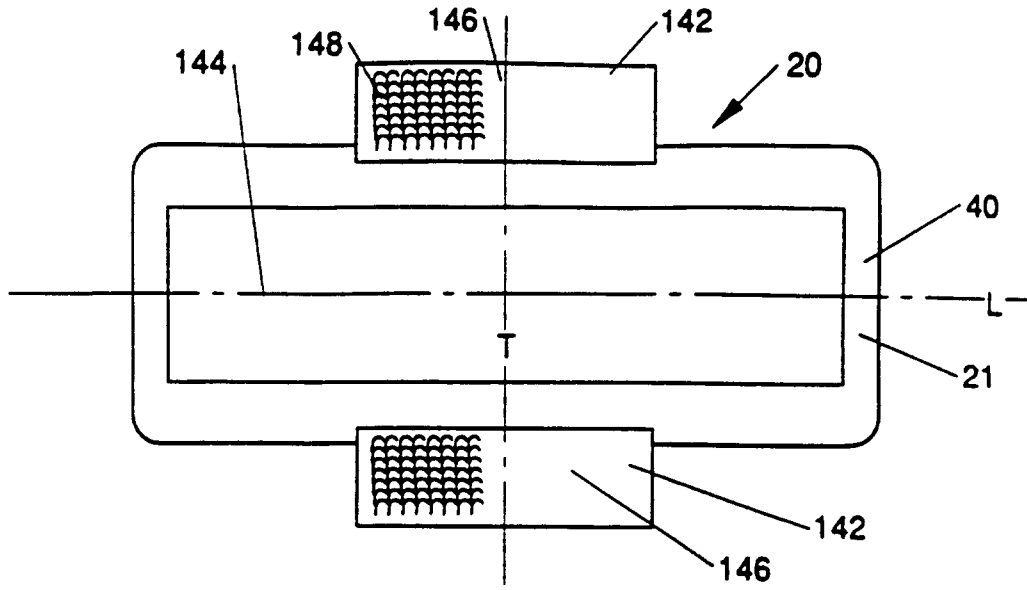

Fig. 44

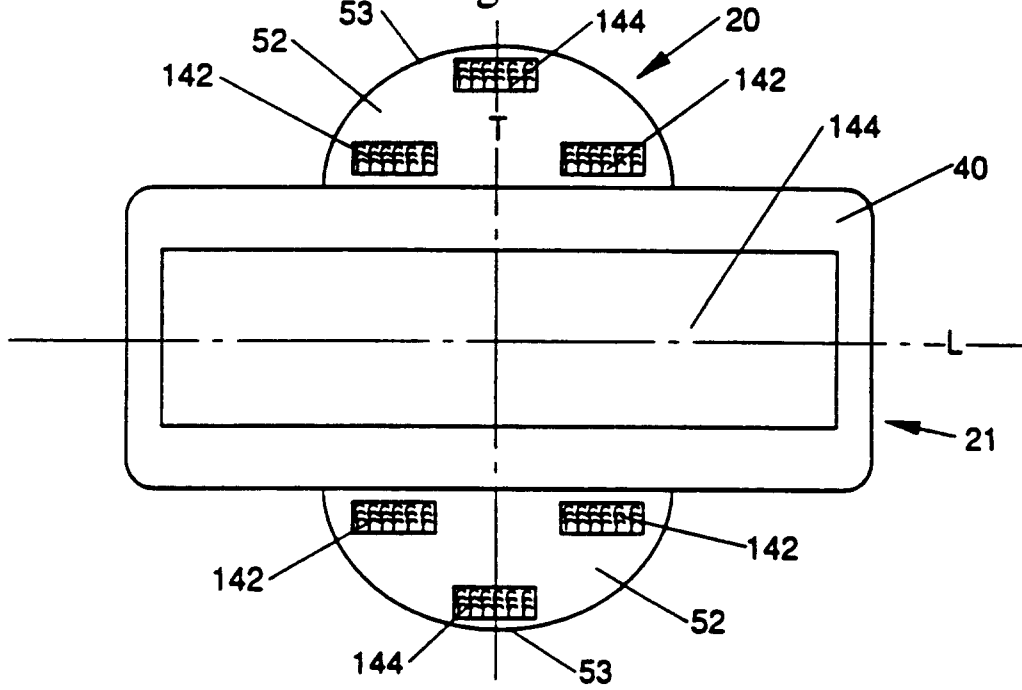

Fig. 45

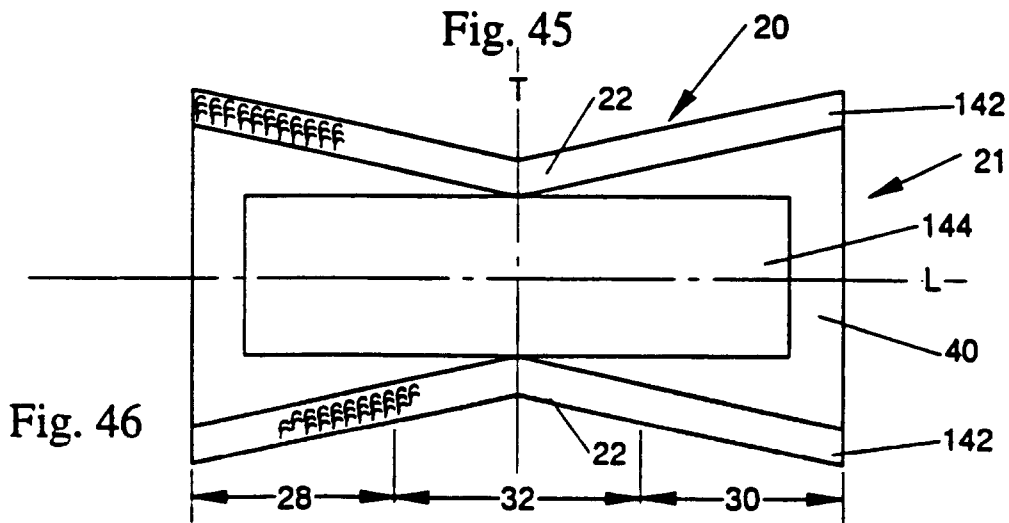

Fig. 46

26/40

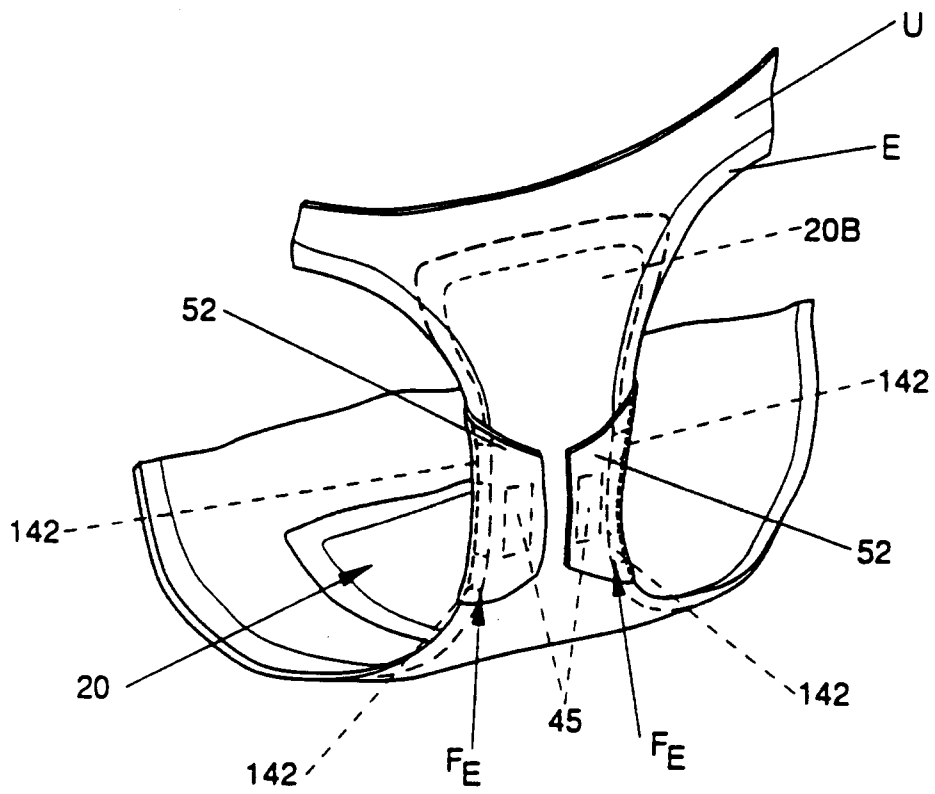

Fig. 44A

27/40

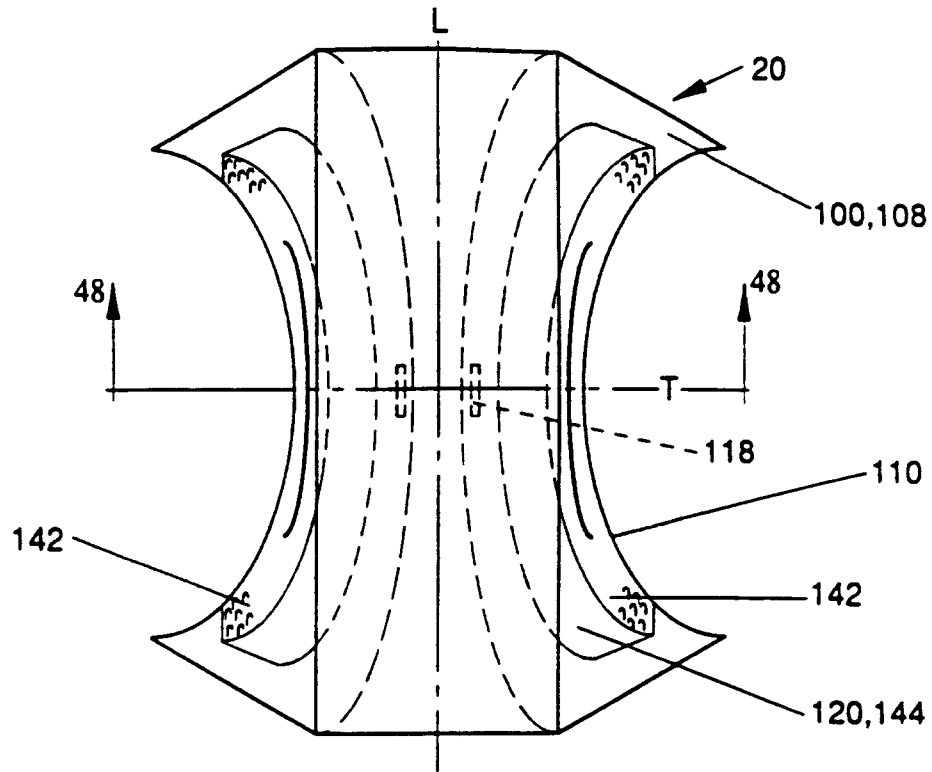

Fig. 47

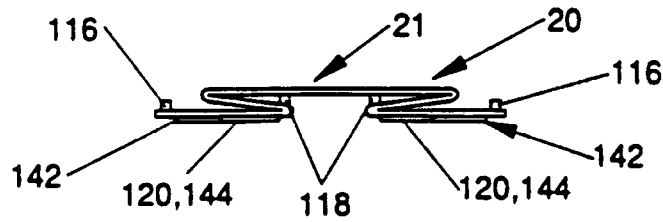

Fig. 48

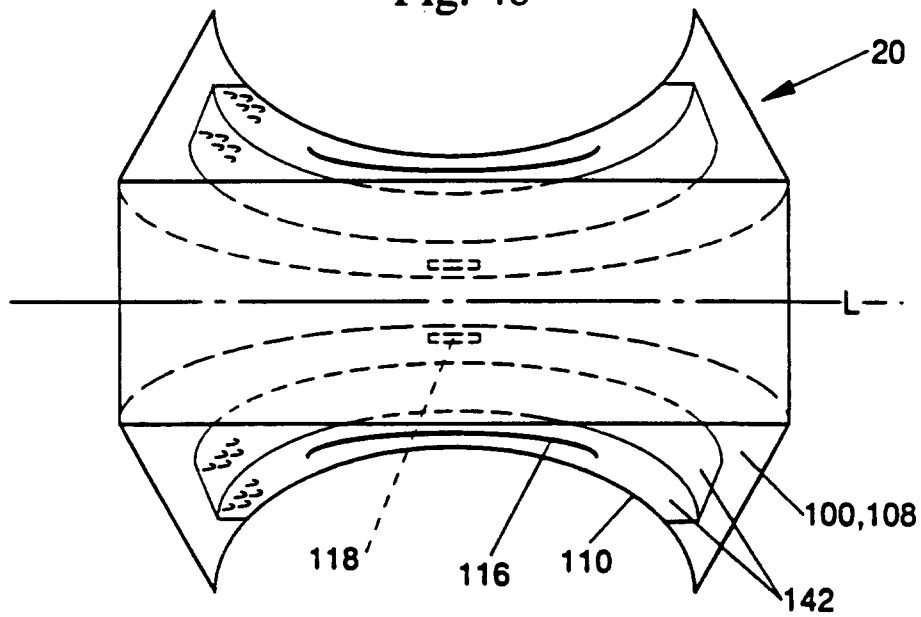

Fig. 49

28/40

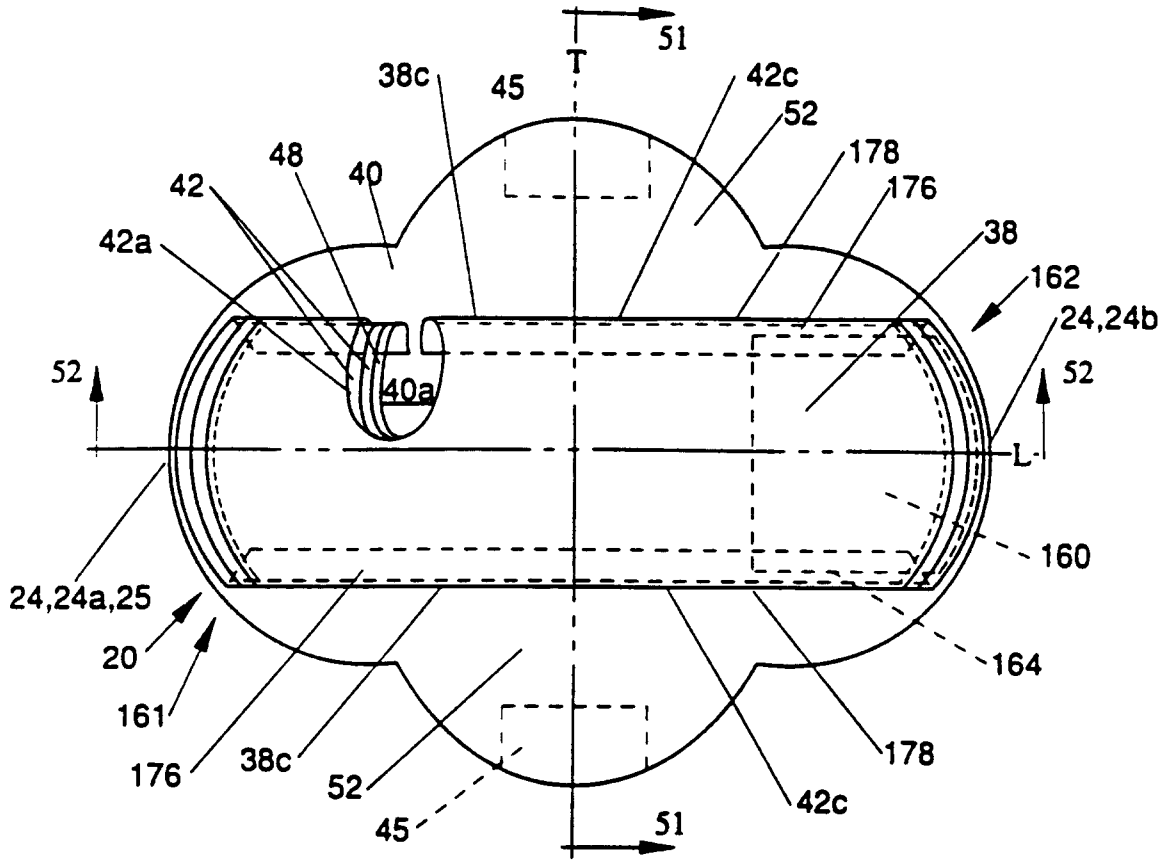

Fig. 50

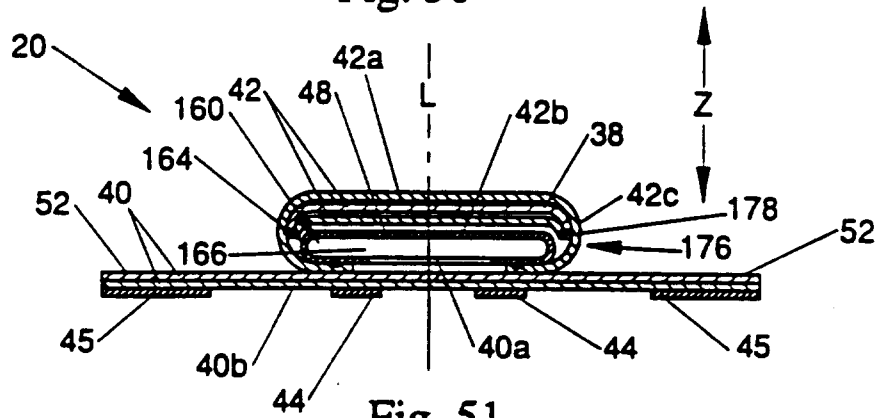

Fig. 51

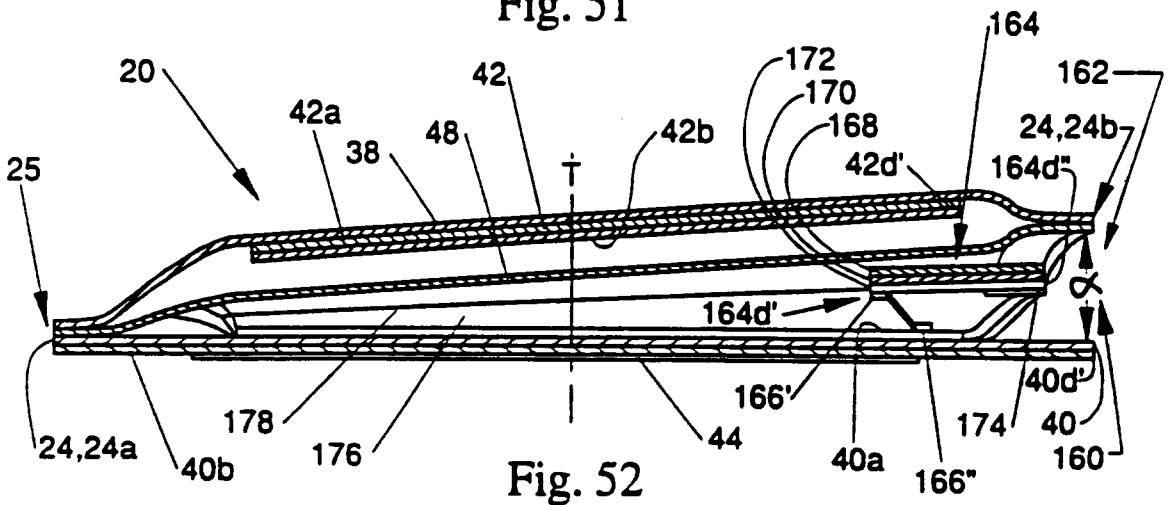

Fig. 52

29/40

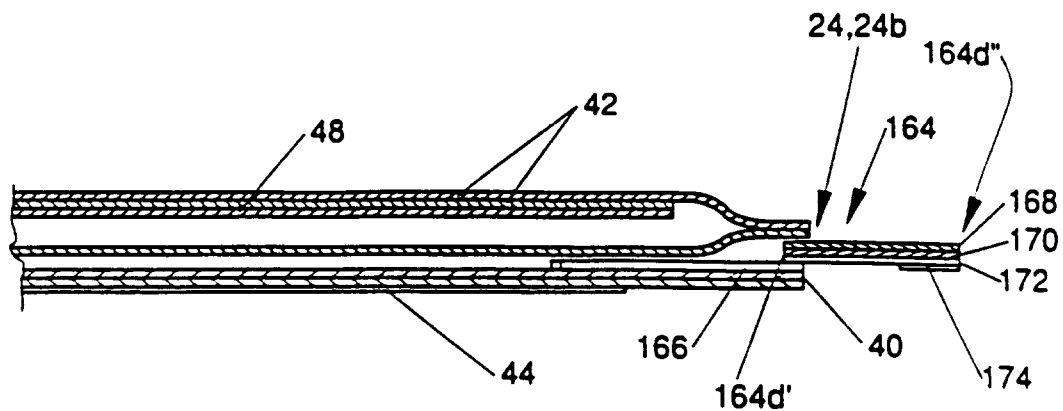

Fig. 53

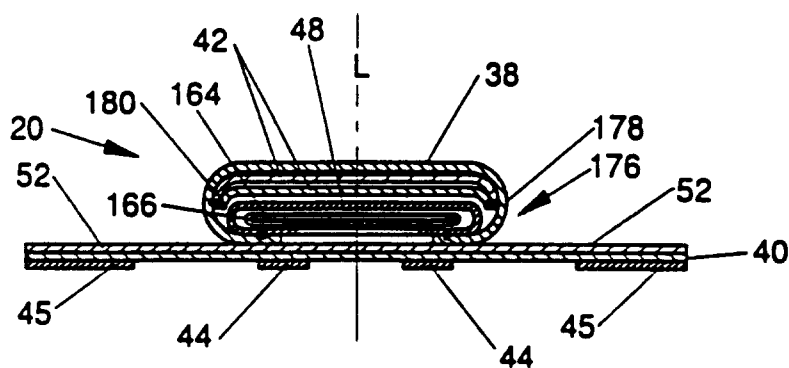

Fig. 54

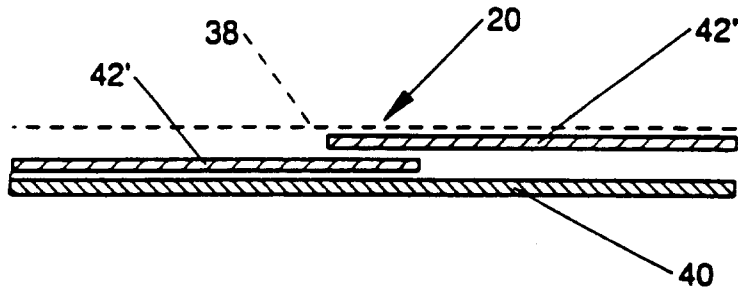

Fig. 55

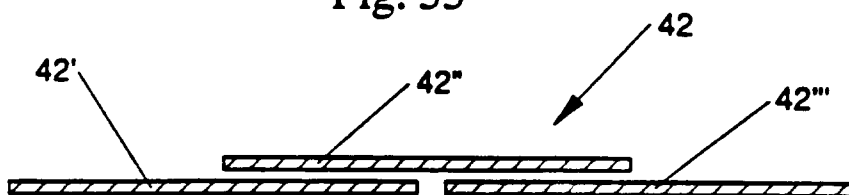

Fig. 56

30/40

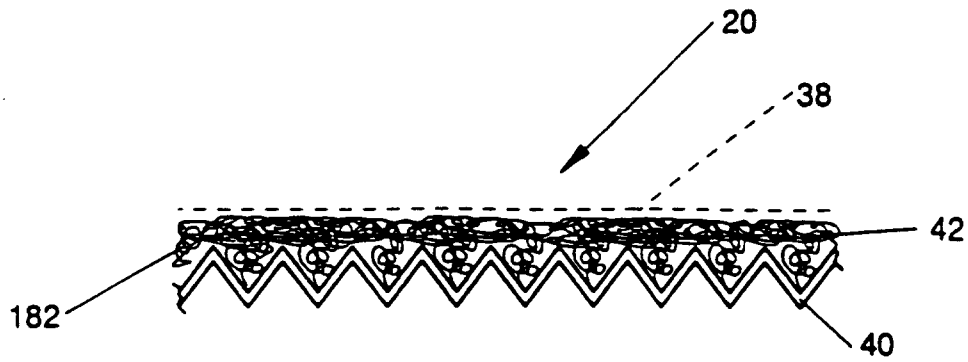

Fig. 58

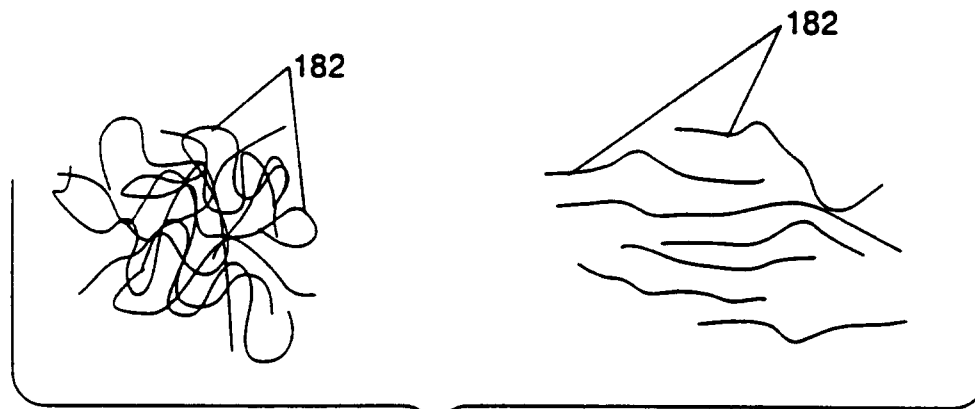

Fig. 59

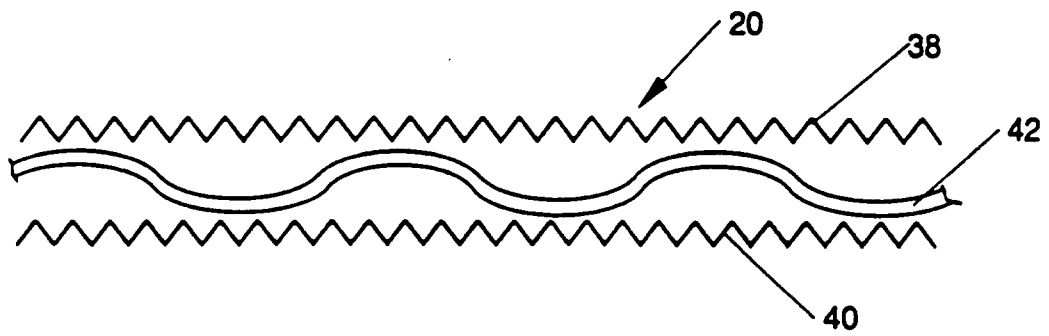

Fig. 60

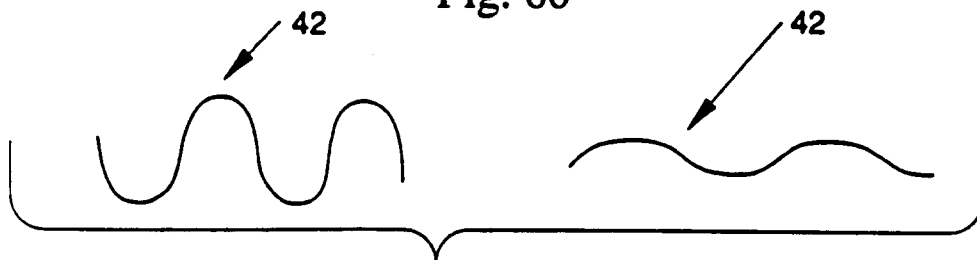
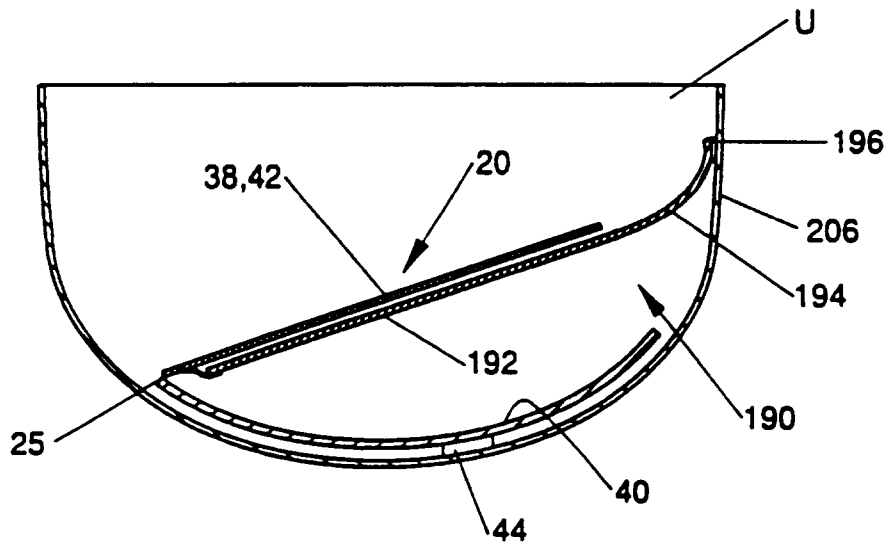
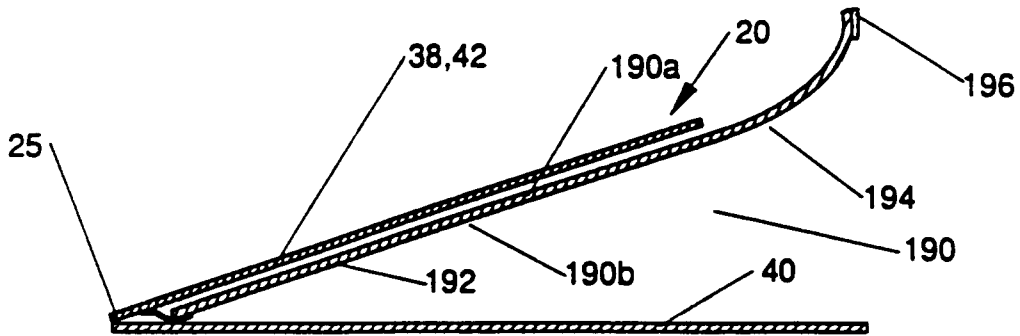
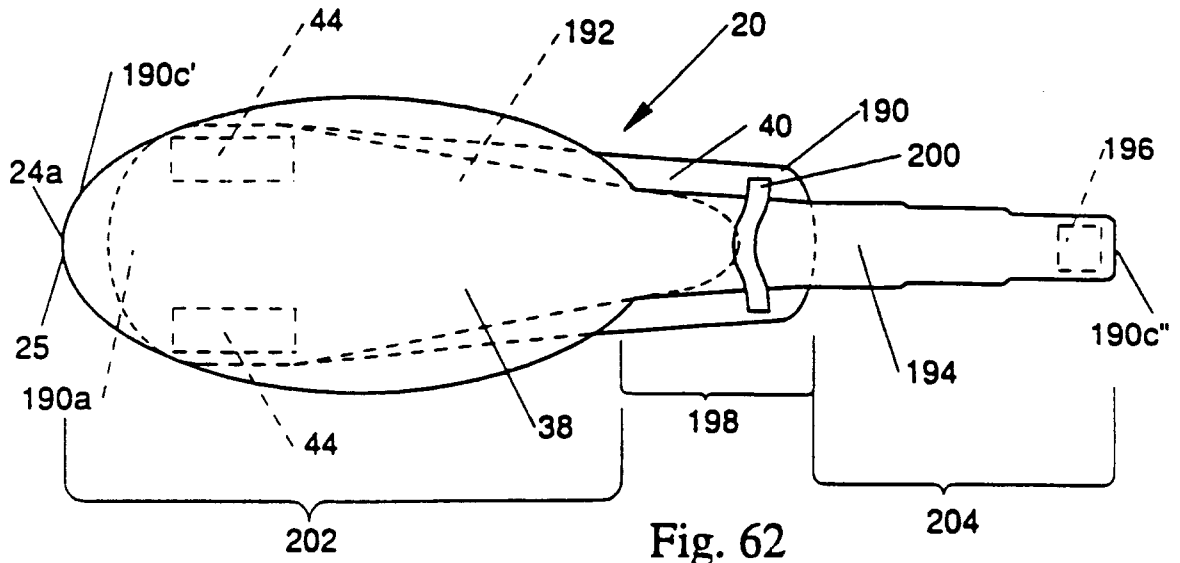
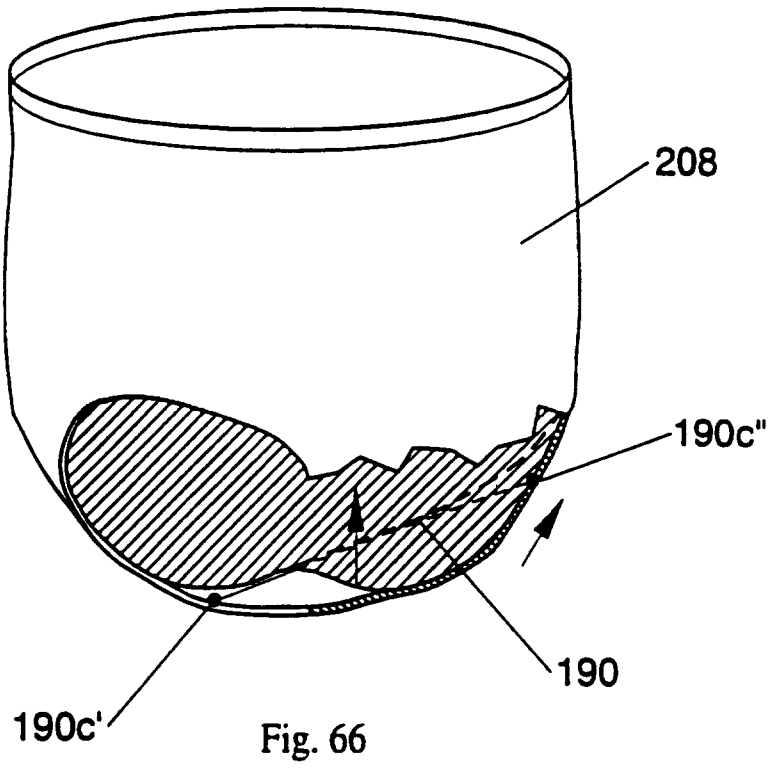
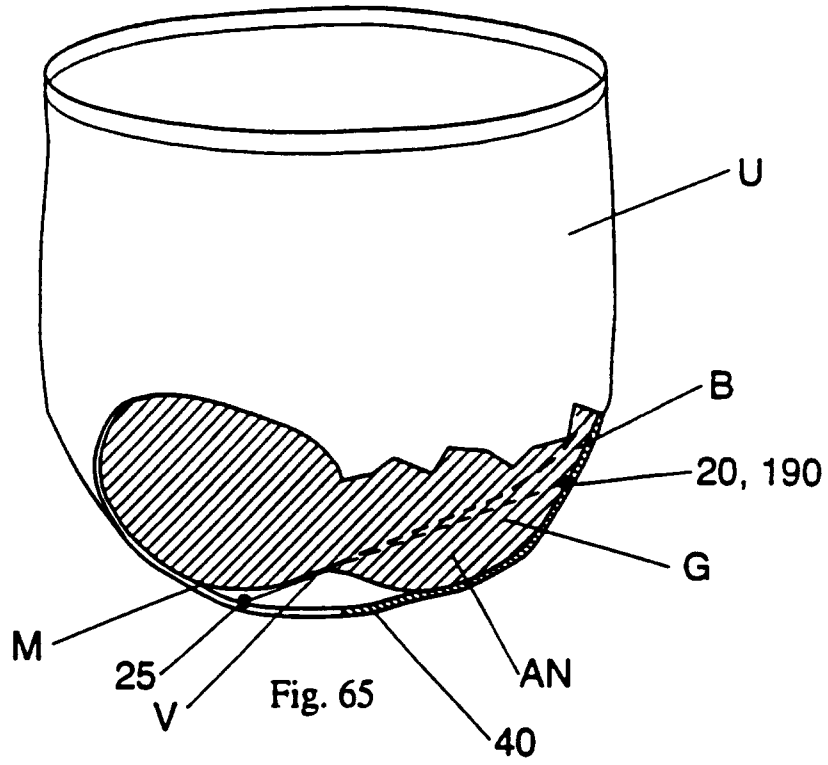

Fig. 61

31/40



32/40



33/40

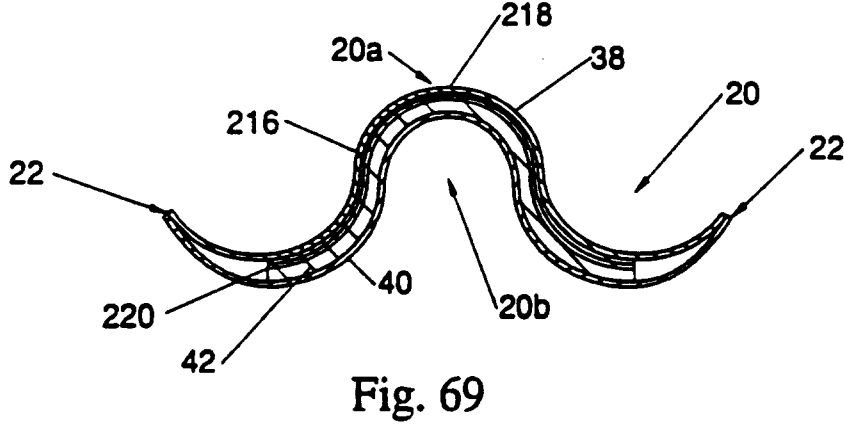
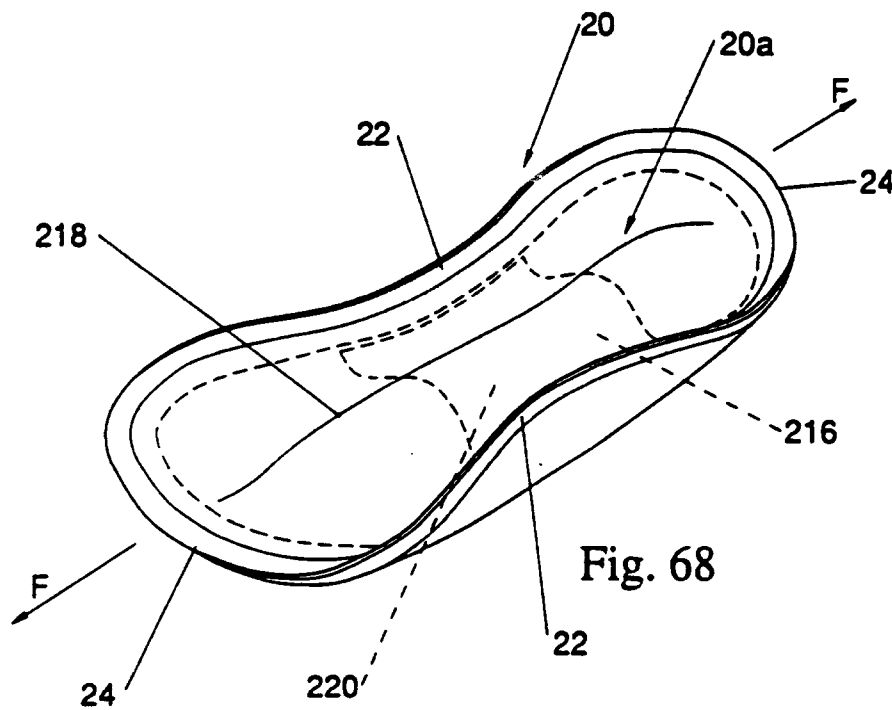
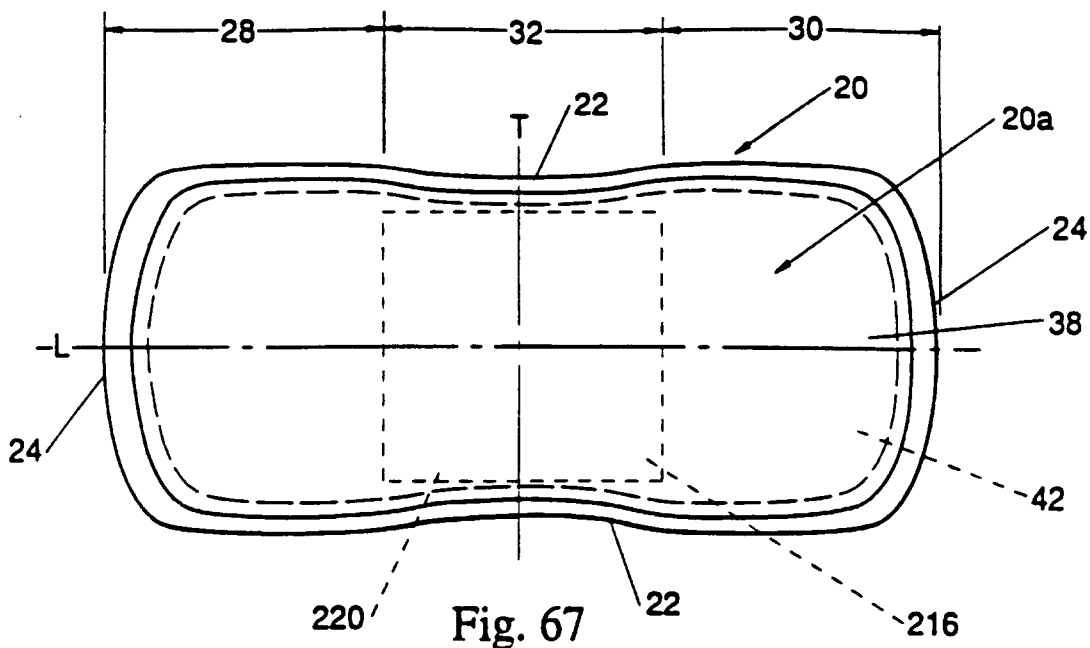

34/40

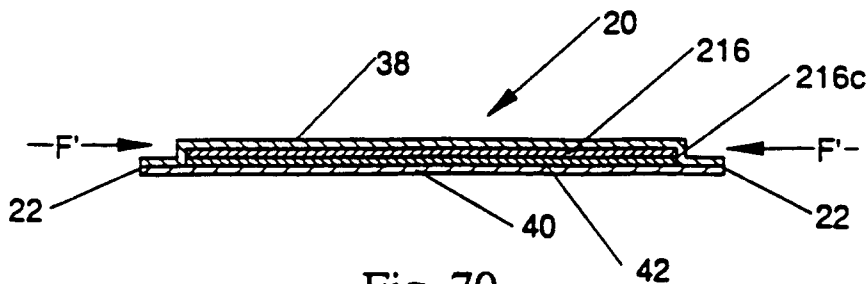

Fig. 70

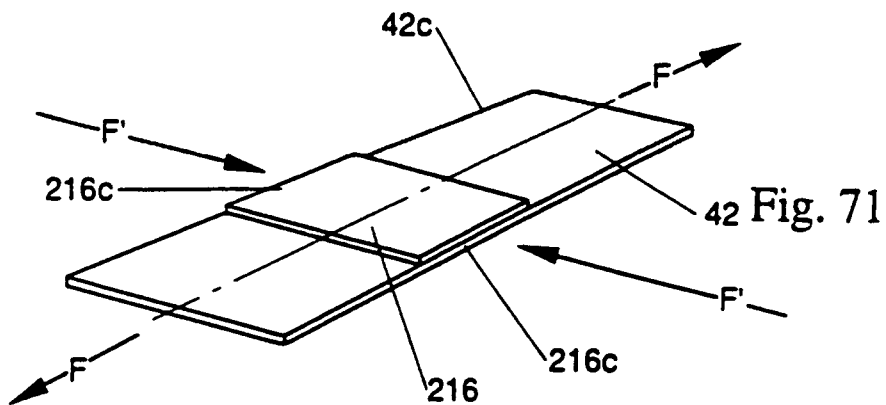

Fig. 71

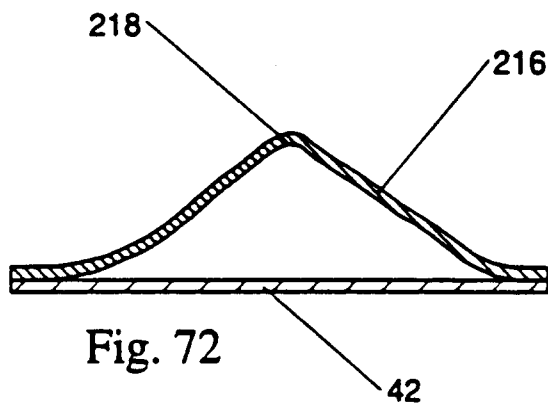

Fig. 72

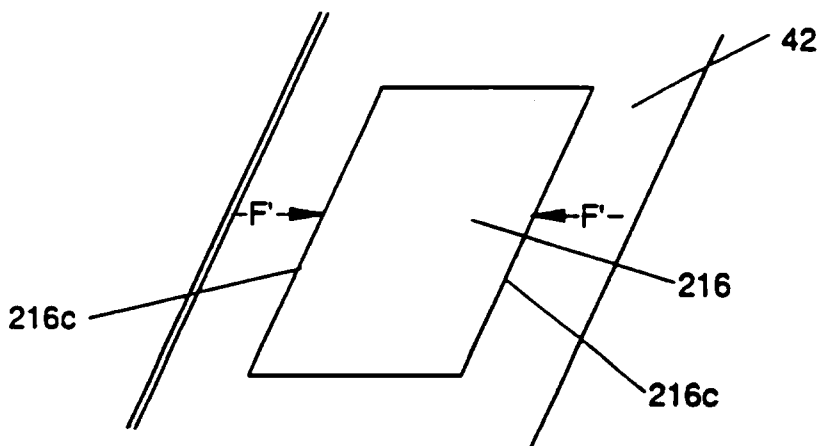

Fig. 73

35/40

Fig. 74

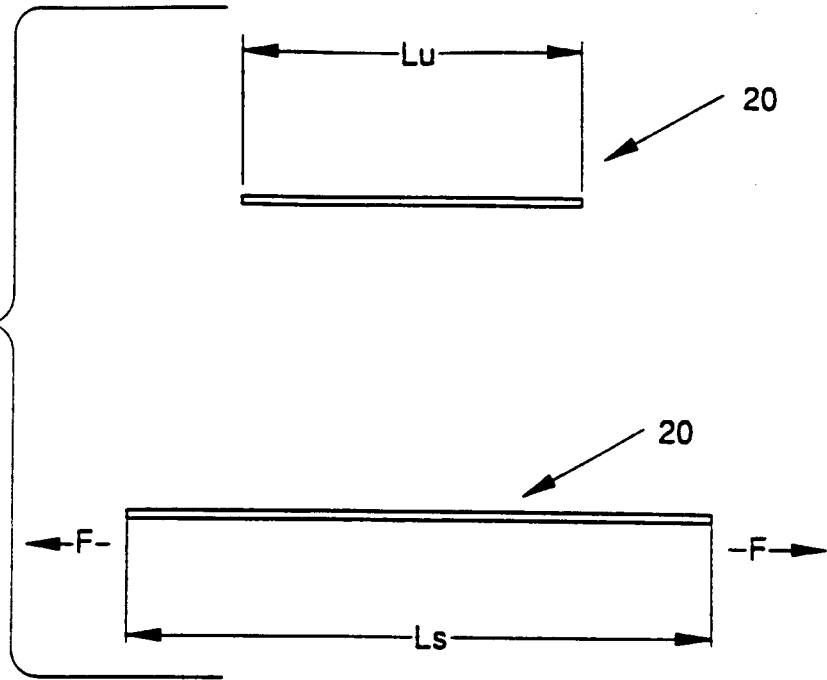
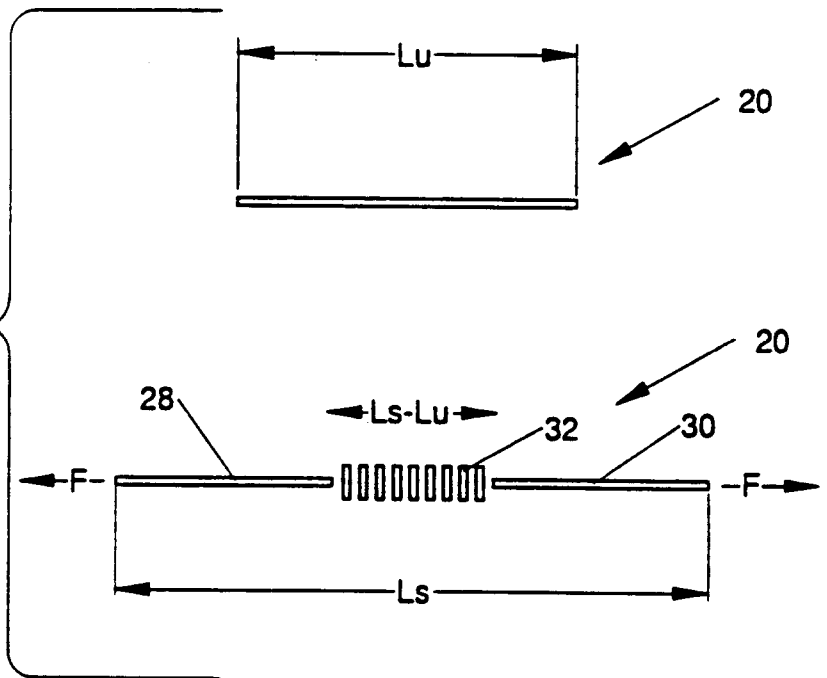

Fig. 75



36/40

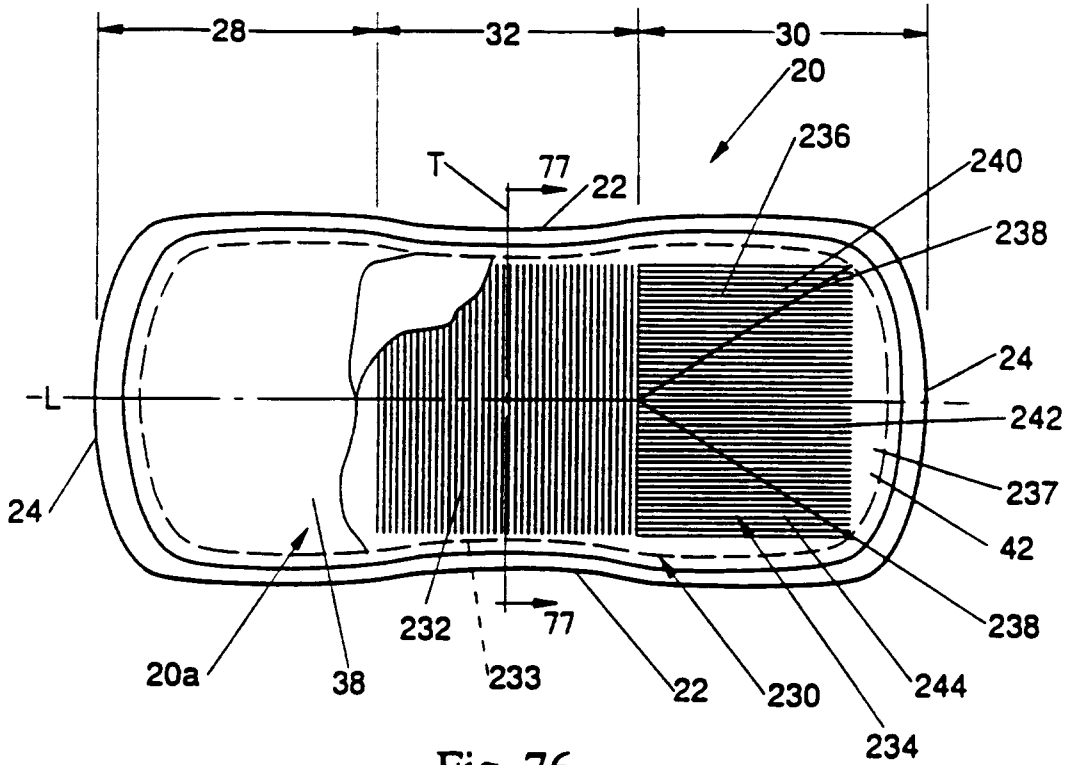

Fig. 76

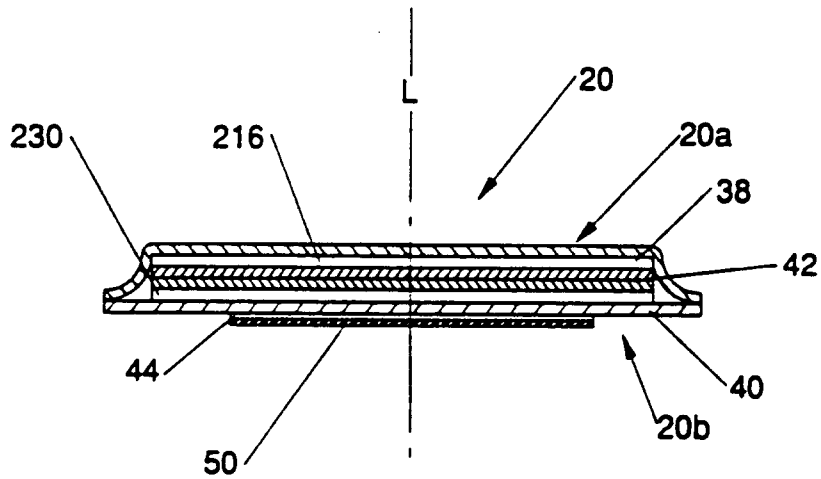

Fig. 77

37/40

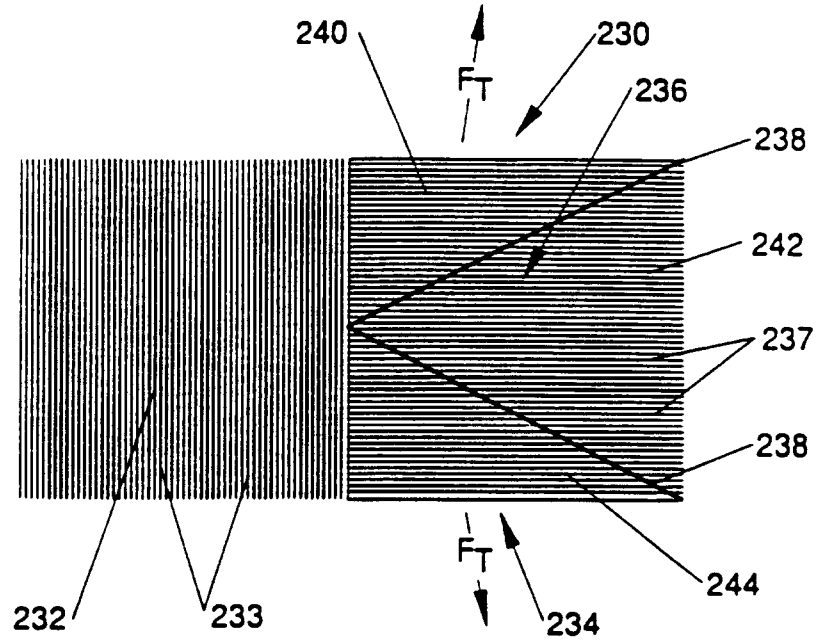

Fig. 78

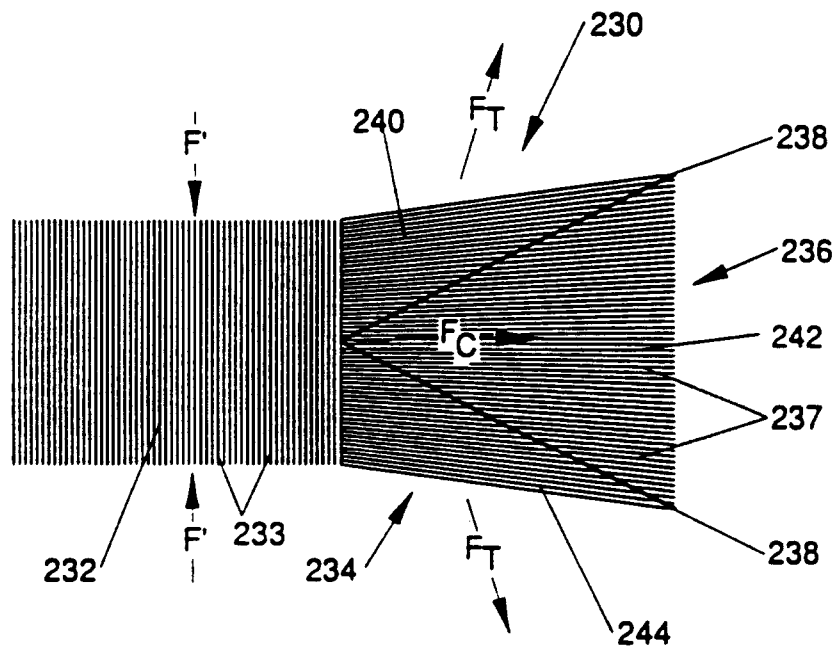

Fig. 79

38/40

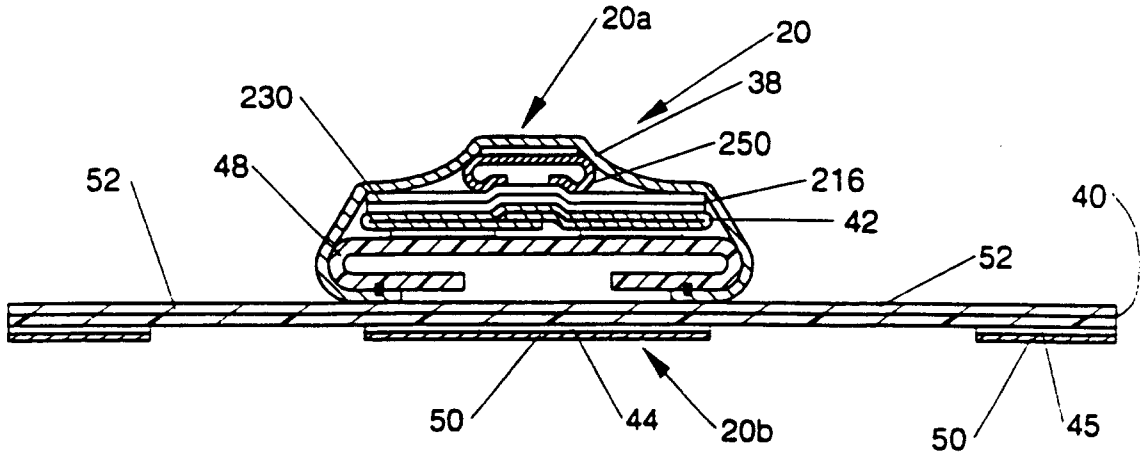

Fig. 80

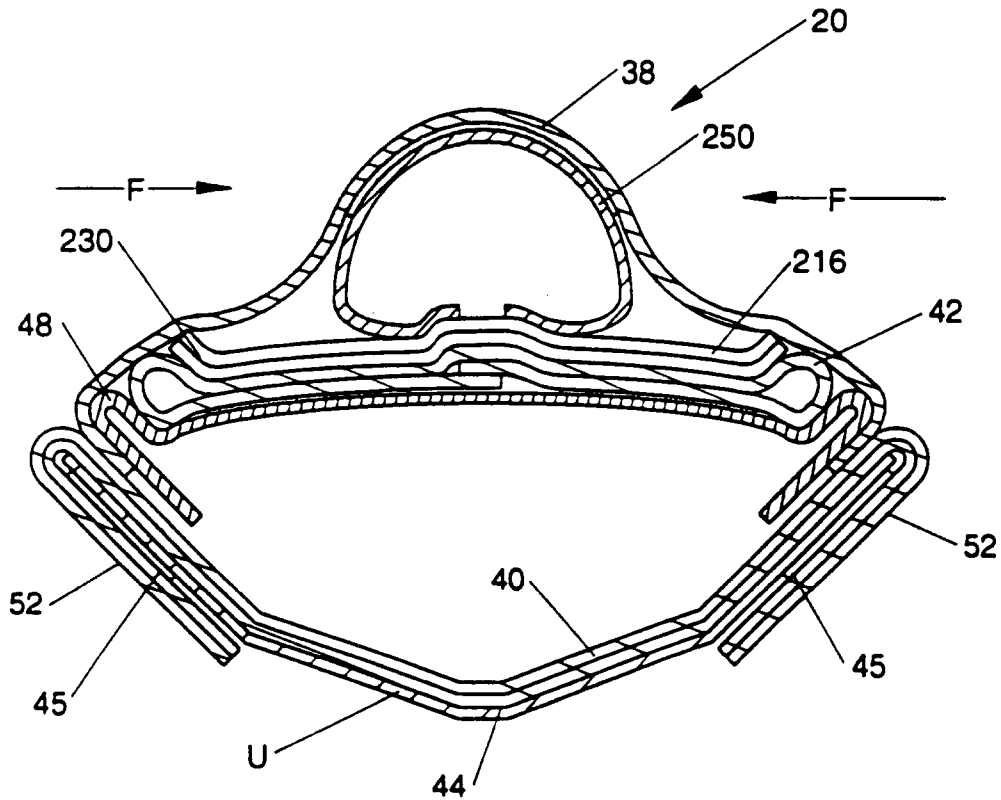

Fig. 81

39/40

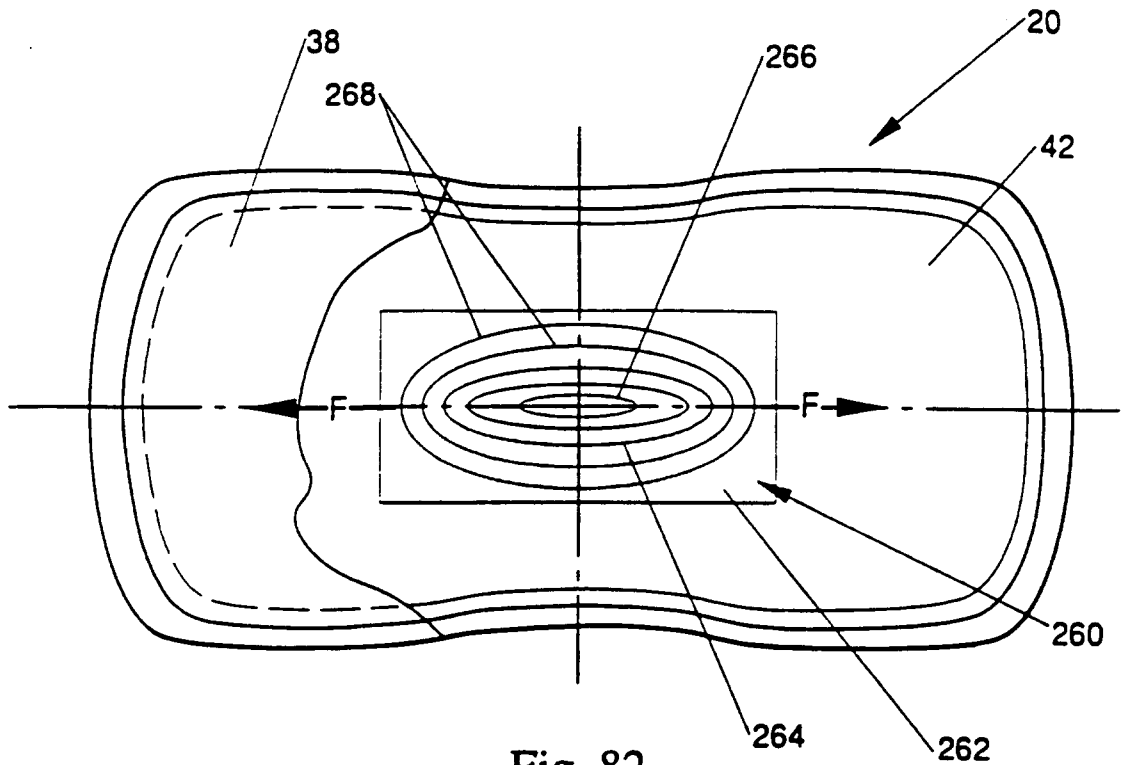

Fig. 82

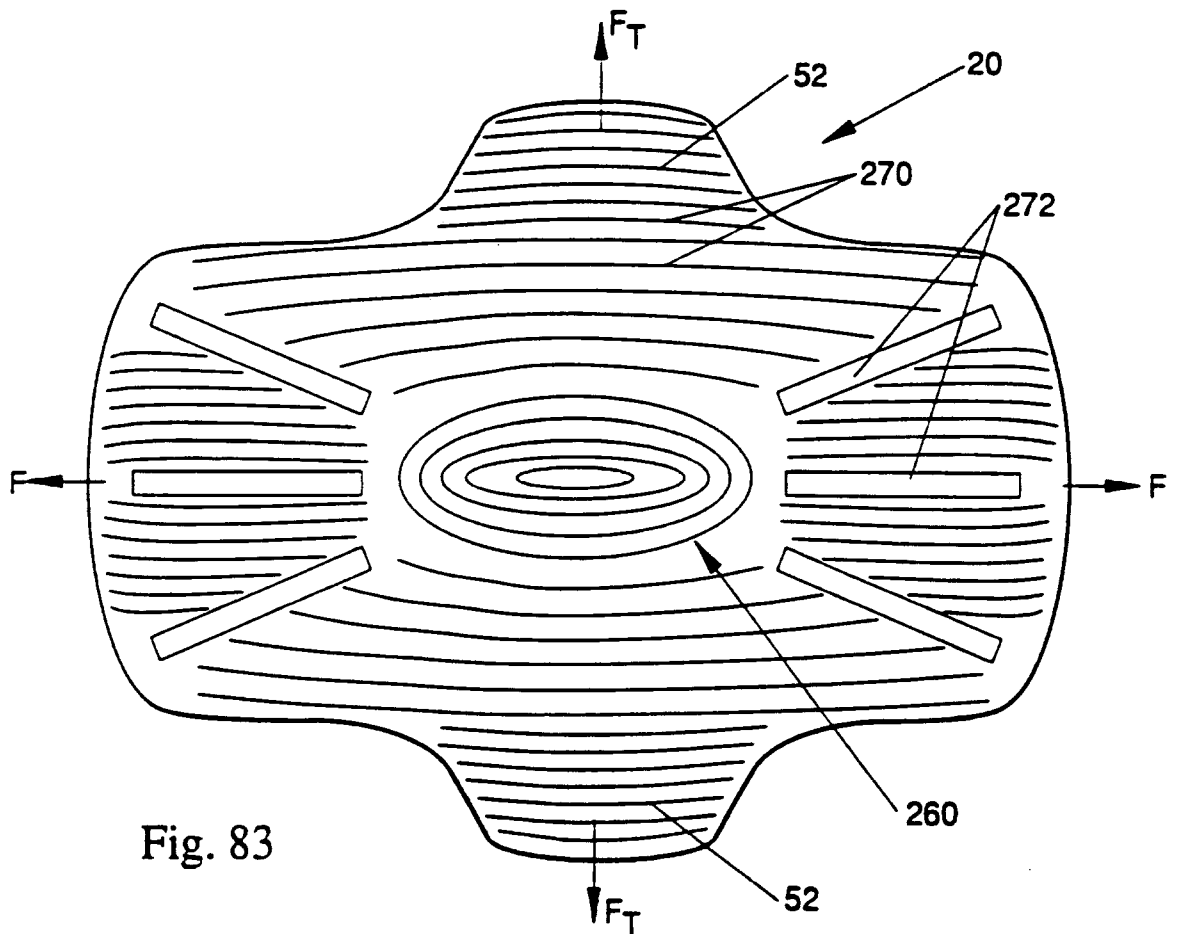

Fig. 83

40/40

