



(72) BÄDORF, Dirk, DE

(72) KÄLBERER, Hartmut, DE

(72) PFAFF, Hans-Georg, DE

(71) CERAMTEC AG, DE

(51) Int.Cl.<sup>6</sup> A61F 2/38

(30) 1997/01/17 (197 01 621.9) DE

(30) 1997/03/20 (197 11 628.0) DE

(54) **FIXATION D'UN ELEMENT DE STRUCTURE CERAMIQUE A  
UNE PARTIE FEMORALE AU MOYEN D'UN COMPOSANT A  
GLISSEMENT**

(54) **FIXATION OF A CERAMIC STRUCTURAL MEMBER BY WAY  
OF GLIDING COMPONENT IN A FEMORAL PART**

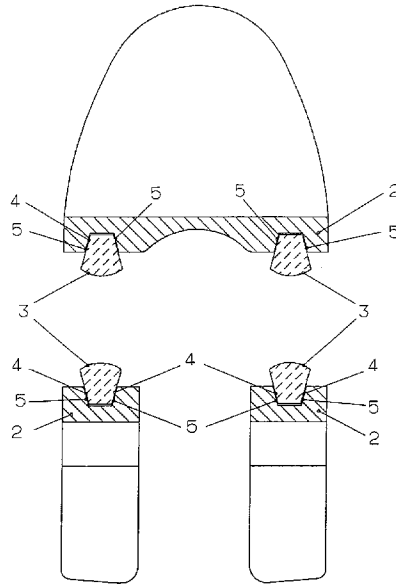

(57) L'invention porte sur une endoprothèse du genou comportant une partie fémorale métallique (2) ancrée dans le fémur, qui s'articule au moyen d'une partie tibiale ancrée dans le tibia. La surface d'articulation de la partie fémorale (2) constitue un élément de structure céramique (3) qui est fixé à la partie fémorale (2) d'une manière mécanique et stable. Différentes solutions sont proposées pour optimiser la fixation de l'élément de structure céramique (3) à la partie fémorale (2).

(57) The invention relates to a knee-joint endoprosthesis with a metallic femoral part (2) anchored in the femur that articulates with a tibial part anchored in the tibia bone, the articulating surface of the femoral part (2) being a ceramic structural member (3) that is connected to the femoral part (2) in mechanically stable manner. With a view to optimising the attachment of the ceramic structural member (3) to the femoral part (2), various possible solutions are proposed.

**Abstract**

The invention relates to a knee-joint endoprosthesis with a metallic femoral part (2) anchored in the femur  
5 that articulates with a tibial part anchored in the tibia bone, the articulating surface of the femoral part (2) being a ceramic structural member (3) that is connected to the femoral part (2) in mechanically stable manner.

10

With a view to optimising the attachment of the ceramic structural member (3) to the femoral part (2), various possible solutions are proposed.

15 (Fig. 1a)

*Fixation of a ceramic structural member  
by way of gliding component in a femoral part*

5 The invention relates to a knee-joint endoprosthesis according to the preamble to Claim 1.

Known from WO 95/23567 is a knee-joint endoprosthesis having a metallic femoral part anchored in the femur that articulates with a tibial part made of polyethylene which is anchored in the tibia bone. The articulating surface of the femoral part is formed by a ceramic structural member that is connected to the femoral part in mechanically stable manner.

15 The object underlying the invention is to improve a knee-joint endoprosthesis according to the preamble to Claim 1 in such a way that the attachment of the ceramic structural member to the femoral part is optimised.

20 In one embodiment according to the invention the ceramic structural member is anchored on the femoral part by means of a conical clamping device. To this end a conical slot is expediently produced in the femoral part, into which slot the conical lateral surfaces of the structural member are inserted. The angle of the conical clamping device preferably amounts to between 5° and 20°. The larger the angle, the more easily the structural members can be removed during a further operation, even after an implantation.

30 In a preferred embodiment the conical clamping device is disposed only in the region above what is the loading zone the knee is extended.

35 In another preferred embodiment the conical clamping device extends over the entire region of the articulating surface.

In an alternative embodiment the structural member is anchored on the femoral part by means of at least one fixing screw. A conical clamping device would be dispensed with in this case.

5

Use is preferably made of two structural members per endoprosthesis. However, use may also be made of only one structural member, which then has two articulating surfaces.

10

In another alternative embodiment the ceramic structural member is connected to the femoral part in non-detachable manner by shrinking, soldering or welding. Soldering also includes active soldering.

15

This attachment can be improved if the ceramic structural member is additionally connected to the femoral part by means of a congruent surface arrangement. The latter may be constituted by, for example, interlocking slots and ribs. In an advantageous configuration, the ceramic structural member is additionally connected to the femoral part by means of a slot/spring connection. The latter is particularly expedient when there is shrinking on. When there is a slot/spring connection, a rib on the structural member, for example, projects into a slot in the femoral part, or vice versa. However, many variants of the congruent surface arrangement are possible.

20

25

In another alternative embodiment the ceramic structural member is in the form of a layer and is secured or applied by vapour deposition, spray application or such like. The structural member is accordingly a layer in this case. Of course, this layer may also consist of several individual layers. A ceramic material for the layer or the other structural members would be, for example, aluminium oxide.

30

35

Further features of the invention will emerge from the figures which are described below. Illustrated are:

5 Fig. 1a a cross-section through a femoral part with a structural member inserted with the aid of a conical clamping device,

10 Fig. 1b the same section as in Fig. 1a, but rotated through 180°,

15 Fig. 2 a lateral section through a femoral part with a structural member mounted with the aid of a conical clamping device, the conical clamping device being disposed only above the loading zone,

20 Fig. 3 the attachment of the structural member to the femoral part with the aid of a fixing screw and

25 Fig. 4 the attachment of the structural member to the femoral part by shrinking, Fig. 4a representing a section like Fig. 1b and Fig. 4b representing a section like Figs. 2, 3.

30 In Figs. 1a and 1b a metallic femoral part 2 is shown in various sections. A slot 5 or two slots 5 are produced in the femoral part 2 in the region of the articulating surface. At their sides these slots 5 have conical surfaces with angles between 5° and 20°. Enclosed in the slots 5 are ceramic structural members 3 which have corresponding conical lateral surfaces, so that a conical clamping device 4 is formed. The structural members 3 are not shown articulating with a tibial part anchored in the tibia bone. In this embodiment the slot 5 extends along the entire articulating surface. However, several slots 5 or individual notches may also

be provided so that the structural member 3 is anchored to the femoral part 2 only at individual points by means of a conical clamping device 4.

5 Fig. 2 shows a lateral section through a femoral part 2 with, likewise, a structural member 3 that is mounted with the aid of a conical clamping device 4. The conical clamping device 4 in this case, as distinct from the embodiment of Fig. 1, is disposed only above what is  
10 the loading zone when the knee is extended. To this end a clamping surface that is not as large as that in Fig. 1 is produced in the femoral part 2.

Fig. 3 shows the attachment of the ceramic structural  
15 member 3 to the femoral part 2 by means of a fixing screw 1. To this end a bore 7 is disposed in the structural member 3 and a thread 6 is disposed in the femoral part 2. The fixing screw 1 projects through the bore 7 into the thread 6 and in this way anchors the  
20 structural member 3 to the femoral part 2.

If necessary, several fixing screws can also be used, which are advantageously disposed sunk in the structural member 3.

25

Fig. 4 shows a femoral part 2 that has a slot 10 on its tibial side. The associated ceramic structural member 3 has a rib 11 that is congruent with the slot. Fig. 4a shows the femoral part 2 in cross-section and Fig. 4b  
30 shows it in longitudinal section. The structural member 3 is attached by shrinking it on. But it may also be soldered on or welded on. In this case the slot/spring connection may optionally be dispensed with.

*Claims*

- 1.) Knee-joint endoprosthesis with a metallic femoral part (2) anchored in the femur that articulates with a tibial part anchored in the tibia bone, the articulating surface of the femoral part (2) being a ceramic structural member (3) that is connected to the femoral part (2) in mechanically stable manner, **characterised in that** the ceramic structural member (3) is anchored on the femoral part (2) by means of a conical clamping device (4).
- 2.) Knee-joint endoprosthesis according to Claim 1, **characterised in that** a conical slot (5) is inserted in the femoral part (2), into which slot the conical lateral surfaces of the structural member (3) are inserted.
- 3.) Knee-joint endoprosthesis according to Claim 1 or 2, **characterised in that** the angle of the conical clamping device (4) amounts to between 5° and 20°.
- 4.) Knee-joint endoprosthesis according to one of Claims 1 to 3, **characterised in that** the conical clamping device (4) is disposed only in the region above what is the loading zone when the knee is extended.
- 5.) Knee-joint endoprosthesis according to one of Claims 1 to 4, **characterised in that** the conical clamping device (4) extends over the entire region of the articulating surface.
- 6.) Knee-joint endoprosthesis with a metallic femoral part (2) anchored in the femur that articulates with a tibial part anchored in the tibia bone, the articulating surface of the femoral part (2) being

5 a ceramic structural member (3) that is connected to the femoral part (2) in mechanically stable manner, **characterised in that** the ceramic structural member (3) is anchored on the femoral part (2) by means of a fixing screw (1).

7.) Knee-joint endoprosthesis with a metallic femoral part (2) anchored in the femur that articulates with a tibial part anchored in the tibia bone, the articulating surface of the femoral part (2) being a ceramic structural member (3) that is connected to the femoral part (2) in mechanically stable manner, **characterised in that** the ceramic structural member (3) is non-detachably connected to the femoral part (2) by shrinking on, soldering or welding.

8.) Knee-joint endoprosthesis according to Claim 7, **characterised in that** the ceramic structural member (3) is connected to the femoral part (2) additionally by means of congruent surface arrangements.

9.) Knee-joint endoprosthesis according to Claim 8, **characterised in that** the ceramic structural member (3) is connected to the femoral part (2) by means of a slot/spring connection.

10.) Knee-joint endoprosthesis according to one of Claims 1 to 9, **characterised in that** two structural members (3) are used per knee-joint endoprosthesis.

11.) Knee-joint endoprosthesis with a metallic femoral part (2) anchored in the femur that articulates with a tibial part anchored in the tibia bone, the articulating surface of the femoral part (2) being a ceramic structural member (3) that is connected



to the femoral part (2) in mechanically stable manner, **characterised in that** the ceramic structural member (3) is in the form of a layer and is secured by vapour deposition, spray application or such like.

1/4

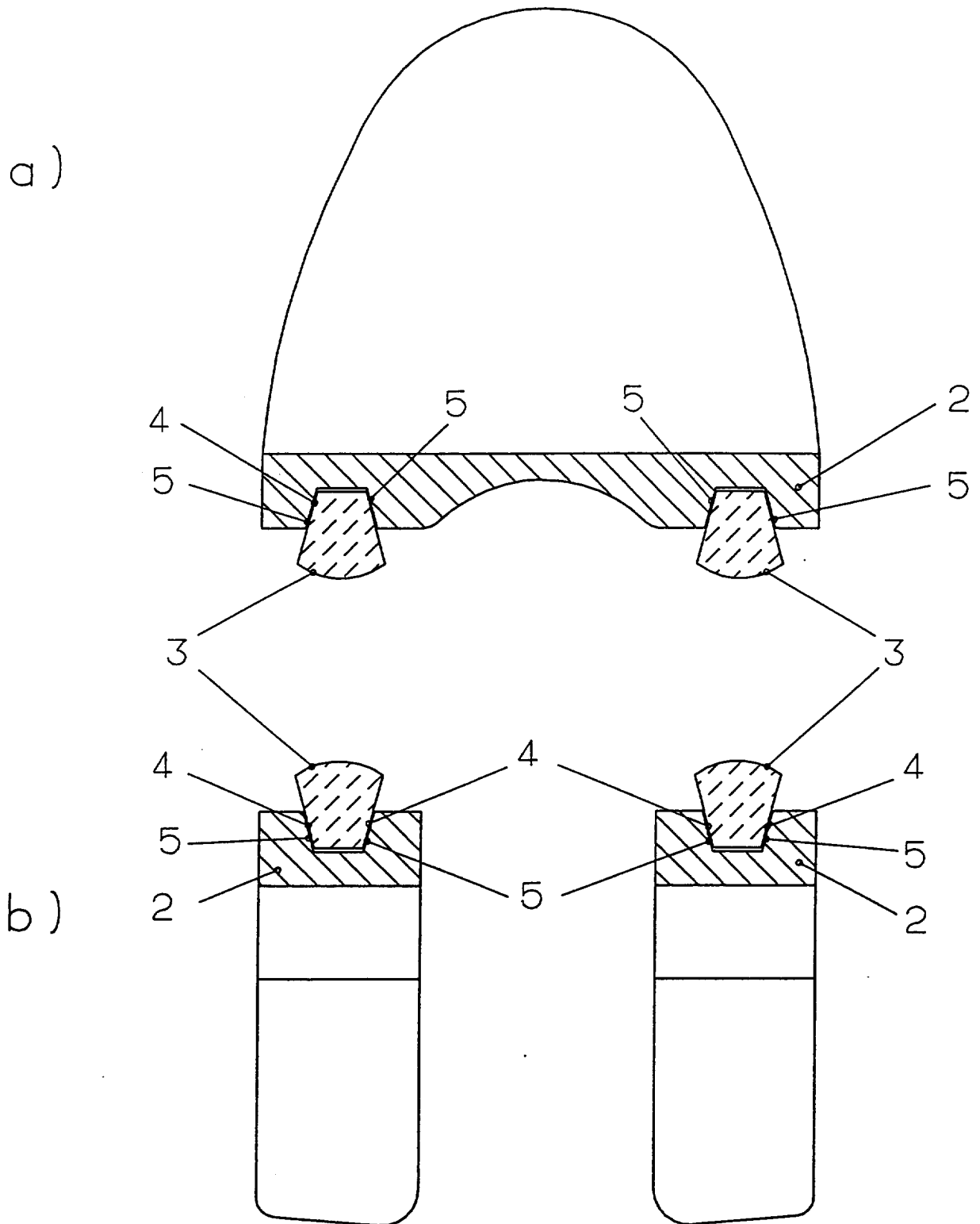

FIG. 1

2/4

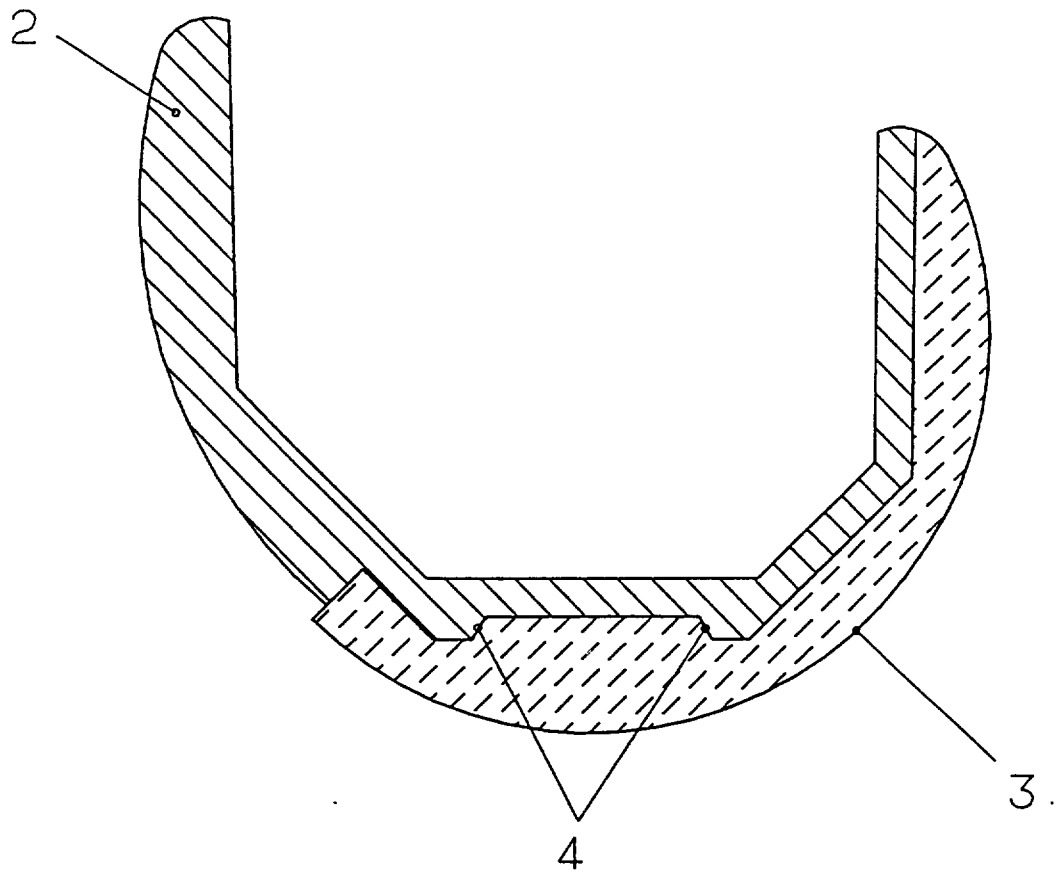

FIG. 2

3/4

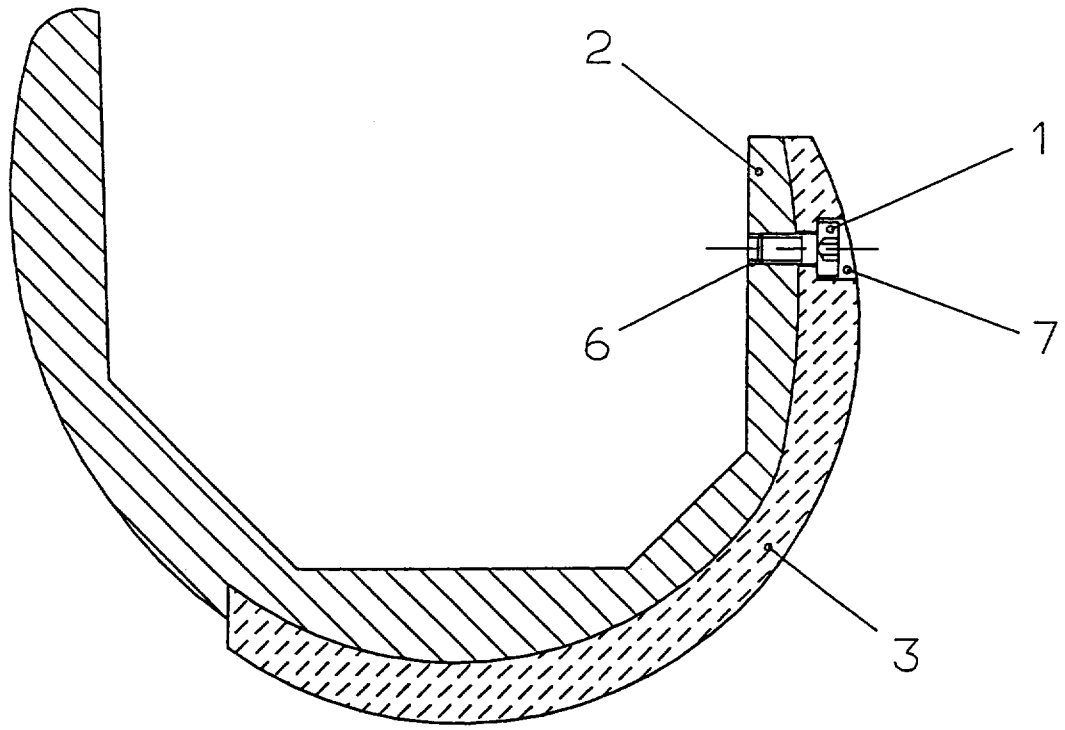

FIG. 3

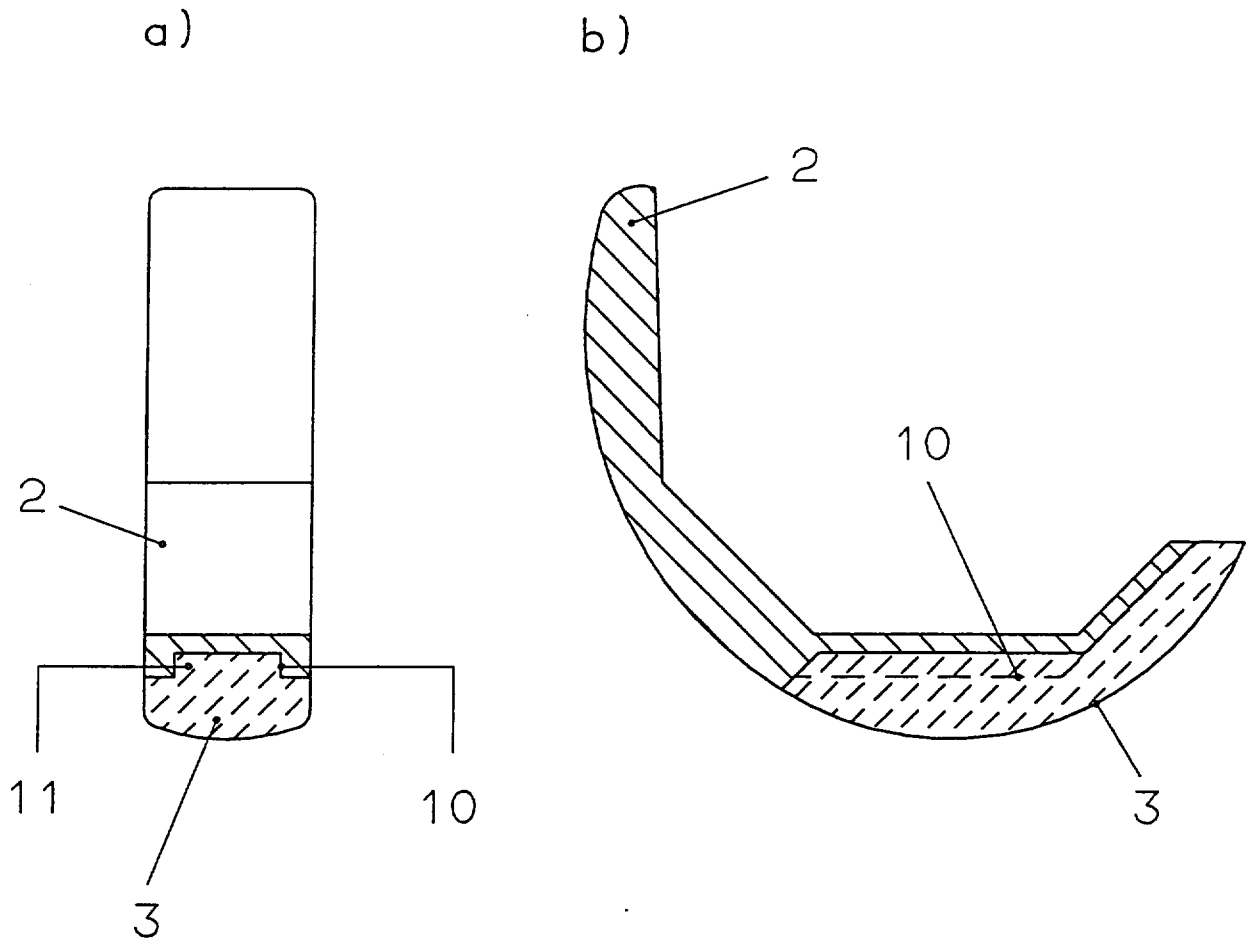

FIG. 4

