

A. McMILLEN.

Bark Mill.

No. 532.

Patented Dec. 26, 1837.

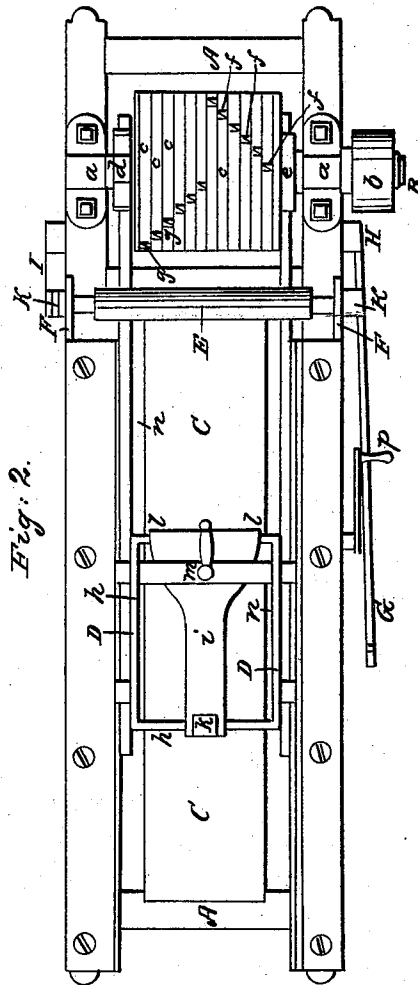
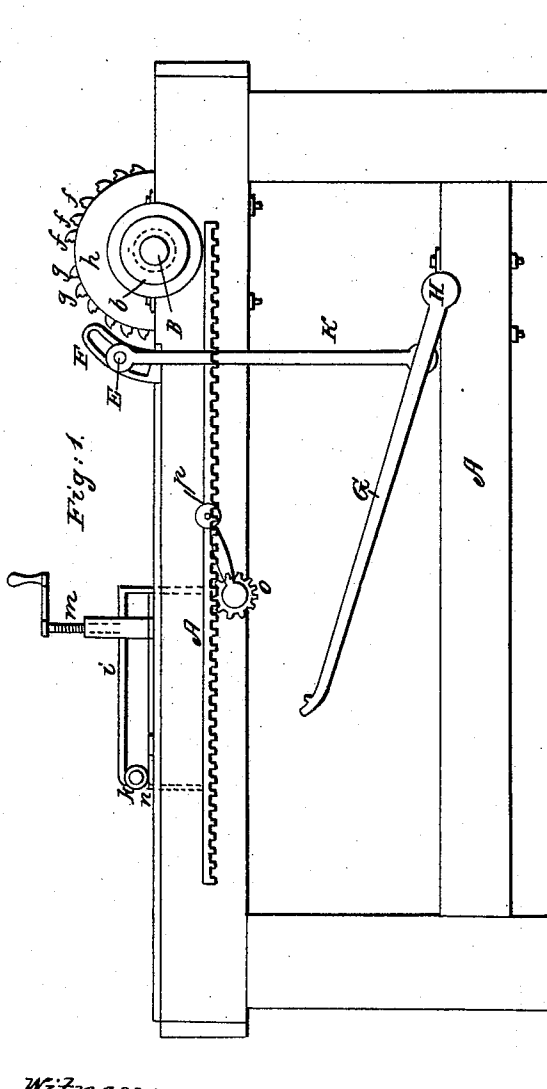

Witnesses:
R. H. Eddy
Esra Lincoln Jr.

Inventor:
Alex. McMillen.

UNITED STATES PATENT OFFICE.

ABNER McMILLEN, OF BEDFORD, NEW HAMPSHIRE.

MACHINE FOR REDUCING AND CUTTING DYE WOODS AND BARK.

Specification of Letters Patent No. 532, dated December 26, 1837.

To all whom it may concern:

Be it known that I, ABNER McMILLEN, of Bedford, in the county of Hillsborough and State of New Hampshire, have invented, 5 made, and applied to use new and useful Improvements in Machinery for Reducing Dye Woods and Bark to a Proper State for the Extraction of Coloring or Tannin.

The disposition, arrangement, and use of 10 the several parts of these improvements, the principle thereof, and several modes in which I have contemplated the application of that principle or character by which it may be distinguished from other inventions 15 and discoveries, I have fully set forth and described in the following specification, and annexed drawings.

A strong frame of wood or metal, A A A, is constructed as represented in Figures 1 and 2, or otherwise shaped and formed for the intended purpose of supporting the remaining parts of the machinery. On the top of this frame is placed a cross shaft B, with suitable bearings *a, a* near each extremity. 25 On one end of the shaft B is placed a driving pulley *b*, on which the belt is wound, which operates the machine. A number of circular plates of metal *c, c, c*, are confined on the shaft B, by a nut *d*, acting against a shoulder *e*, or in any other convenient manner. At suitable points in the circumfer- 30 ences of these plates, the cutters *f, f, g, g*, are fixed by dovetailed projections as seen at *h*, entering into corresponding notches in the edges of the plates; or they may be otherwise attached in any proper manner. As each cutter is placed a certain distance back of the other, the whole together take spiral 40 directions around the circumference of the cylinder of plates, and by this order of construction each cutter is caused to operate on the wood before the next succeeding one, each row cutting from the circumference of the block or log toward the center.

The shape of the cutters is denoted in 45 Figs. 1 and 2, the cutting edges being beveled or inclined each way from the center of the cylinder, in order that the particles cut may be thrown out and not clog together and 50 thereby impede the action of the machine. C C is the platform for sustaining the log

or piece of wood to be cut. One end of the log is gripped and held fast in the metallic frame D D. This frame may be formed as represented in the drawing, or in any other 55 convenient manner. As therein constructed, it consists of a rectangular frame *h h* supporting the gripper *i* which turns at one end by a joint *k* and has teeth filed at its other extremity, to hold the wood firmly when 60 placed between them and teeth formed on the edge *l l* of the frame D. A screw *m* serves to press downward the gripper *i* on the stick. The frame D is supported on two horizontal racks *n, n* moving in suitable 65 guides attached to the framework A A. These racks are connected to, and are operated by pinions *o*, turned by a crank *p*, or in any other convenient manner, as the stick is reduced by the cutters. 70

A roller E, whose ends move in guides F, F, is pressed on the top of the log, so as to keep it in its proper position on the platform C, by a weight, hung on the extremity 75 of a lever G. The lever G is attached at its other extremity to the horizontal shaft H, while at a suitable intermediate point of it (the lever G) is affixed one of the connecting rods K,—which supports one end of the roller E; and the other connecting rod K is 80 affixed to a lever I on the other end of the shaft H.

I am aware that dye woods have been reduced by circular saws and other machinery operating on the end of the sticks applied in 85 various ways; but

What I claim as my invention, and consider as new in the above described machinery is as follows.

The construction of the carriage in combination with a cylinder of cutters, and a depressing roller, constructed and operating 90 substantially as herein described.

In testimony that the above is a true specification of my said inventions and improve- 95 ments, I have hereunto set my hand this twenty first day of March in the year of our Lord eighteen hundred and thirty seven.

ABNER McMILLEN. [L. s.]

Witnesses:

R. H. EDDY,
EZRA LINCOLN, Jr.