

Dec. 23, 1969

B. K. MILBOURNE, SR

3,485,287

PLEATED CURTAIN WALL

Filed May 13, 1968

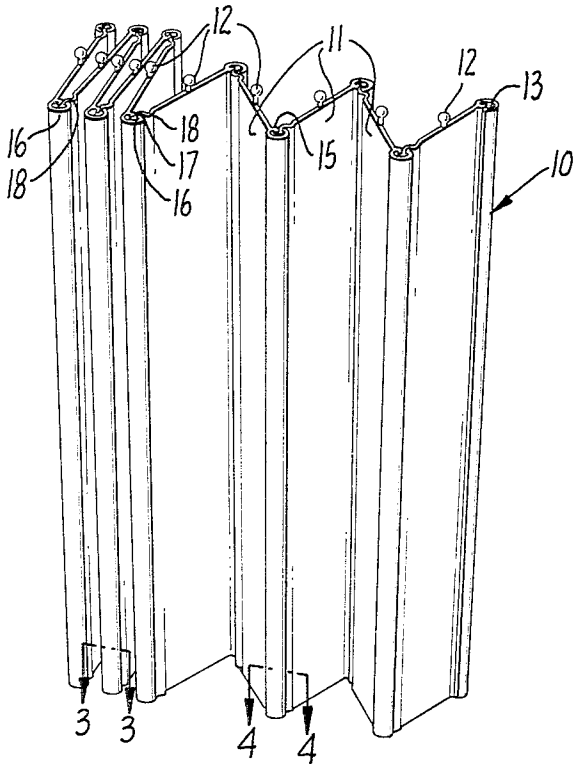

FIG. 1.

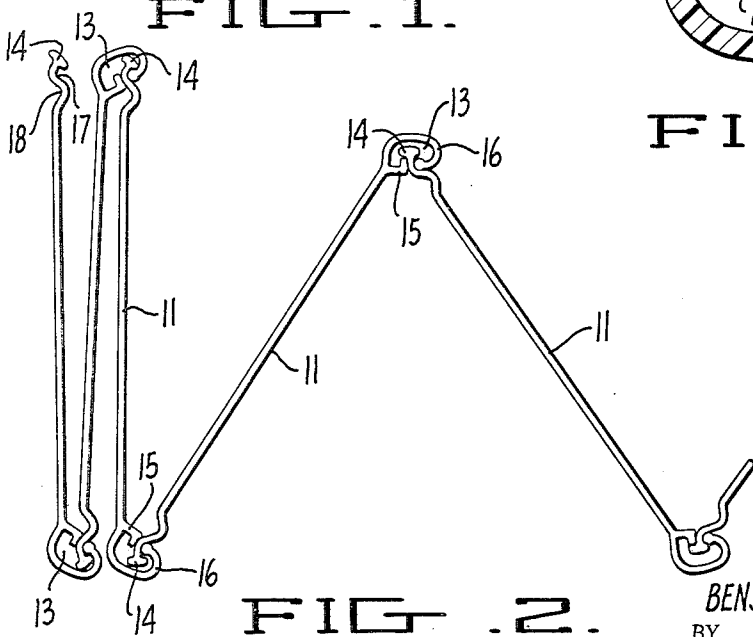

FIG. 2.

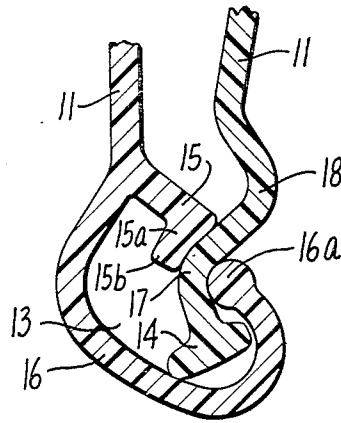

FIG. 3.

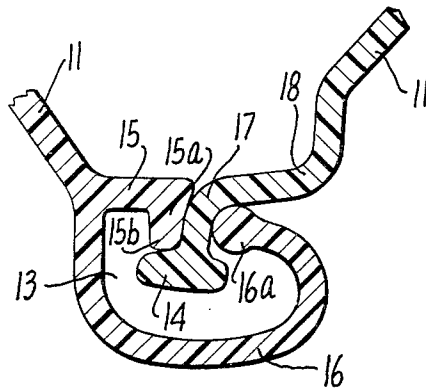

FIG. 4.

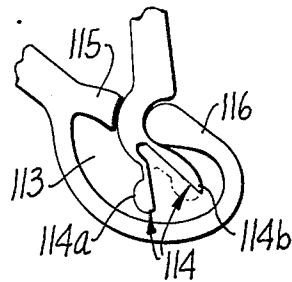

FIG. 5.

INVENTOR
BENJAMIN K. MILBOURNE, SR

BY
Eckhoff and Hoppe
ATTORNEYS

1

2

3,485,287

PLEATED CURTAIN WALL

Benjamin K. Milbourne, Sr., Los Angeles, Calif., assignor
to Cortina West, Inc., a corporation of California
Filed May 13, 1968, Ser. No. 728,402
Int. Cl. E06b 3/48; A47g 5/00

U.S. Cl. 160—235

1 Claim

ABSTRACT OF THE DISCLOSURE

A pleated curtain wall comprised of a plurality of essentially identical panels adapted to be made of extrudable plastics, each panel having a pair of integrally formed parallel edges, one edge of each panel being pivotally interlocked with an edge of another panel and joined thereto with a slidable tongue and groove fit; a curtain wall panel formed with a foot that engages the rib of an interlocking panel to limit the relative pivotal movement therebetween and establish a predetermined angle of pleat; a curtain wall panel having an integral edge including a curved leg terminating in a bead of essentially semicircular cross-section, said bead defining a pivot upon which an interlocking panel may be articulated; a curtain wall panel having an integral edge including a double-curve section comprising a first curvature for pivoting one panel upon and between the surfaces of a foot and bead of another panel, and a second curvature that allows the walls of a pair of interlocking panels to be selectively positioned relative to the others including a position of parallelism and a position in which one panel forms a predetermined angle with the other.

This invention generally relates to pleated curtain walls or hinged draperies. More particularly, the invention involves a novel construction for making identical panel members that incorporates an integral hinging mechanism for joining the panels with a pivotal interlock.

In brief, this invention contemplates and teaches a pleated curtain wall comprising a plurality of essentially identical panels, each panel having a pair of integrally formed parallel edges, one edge of each panel being pivotally interlocked with an edge of another panel and joined thereto with a slidable tongue and groove fit.

It is one object of this invention to provide extrusions made of plastic material that may be rapidly assembled into a pleated curtain wall.

Another object is to provide a curtain wall comprised of essentially identical panels that may be manufactured and assembled at a very low cost.

A further object is to provide curtain walls of the kind described and having interlocking edges that limit the relative pivotal movement between connecting panels to establish a predetermined angle of pleat.

Another object is to provide a curtain wall of the kind described including a plurality of identical panels, one edge of each panel being curved and ending in a bead of essentially semicircular cross-section and defining a pivot upon which an interlocking panel may be articulated.

Another object of the invention is to provide curtain walls of the kind described comprised of a plurality of identical panels formed by extrusion and pivotally interlocked to provide an accordion-pleated arrangement, whereby two interlocking panels may be selectively pivoted relative to the other and positioned either in parallelism or in a stop position at which the planar portion of one panel forms a predetermined angle with the planar portion of the other.

Other objects of this invention will become apparent in view of the following detailed description and the accompanying drawings.

In the drawings forming a part of this application and in which like parts are identified by like reference numerals throughout the same.

FIG. 1 is a perspective view of a curtain wall formed of a plurality of panels, each panel constructed in the preferred manner contemplated by this invention;

FIG. 2 is a plan view of a portion of the curtain wall shown in FIG. 1;

FIG. 3 is an enlarged detail and section taken on lines 3—3 of FIG. 1;

FIG. 4 is an enlarged detail and section taken on lines 4—4 of FIG. 1; and

FIG. 5 is a detail and section illustrating a second form of panel construction contemplated by this invention.

Referring to FIG. 1 in particular, there is shown a pleated curtain wall 10 comprised of a plurality of essentially identical sheet-like members or panels 11, each panel being pivotally interlocked with an edge of an adjacent panel. The curtain wall as a whole is adapted to be suspended from an overhead track (not shown) by means of knobs or projections 12, one knob being provided at the top of each panel. Such devices, however, are largely conventional and no patentable importance is attached to the means for suspending the curtain wall. In fact, many other suspension means can be utilized in connection with this invention, or the invention may be practiced independently of and without the use of any suspension means.

This invention more particularly relates to the construction of the panel members 10, each panel having a pair of integrally formed parallel edges. With particular reference to FIGS. 2-4, one edge of each panel is pivotally interlocked with an edge of another panel and joined thereto with a slidable tongue and groove fit. For this purpose, one parallel edge of each panel defines a slotted passage 13, the other parallel edge of each panel terminating in a rib 14 slidably received within the slotted passage of a connecting panel. Slotted passage 13 is more particularly defined by a pair of legs 15 and 16. Leg 15 projects at an angle relative to the median plane of its panel and terminates in a foot 15a, said foot having a toe 15b projecting into the passage 13. Toe 15b serves as a stop that may be engaged by the rib 14 of an interlocking panel. Such engagements limit the relative pivotal movement between panels and establish a predetermined angle of pleat. This relationship is best shown in FIG. 4.

Leg 16 is preferably formed on a curve and ends in a bead 16a of essentially semicircular cross-section. This bead defines a pivot upon which an interlocking panel may be rotated with relative ease. The distance or spacing between the foot 15a and bead 16a is substantially the same as, but slightly greater than, the wall thickness of a double-curve section of each panel 11. This double-curve section, which is interposed between a relatively large planar section of the panel and its rib 14, defines a first curvature 17 and a second curvature 18. Curvature 17 provides a concave surface that complements the convex surface of bead 16a. This relationship, together with the fact that the spacing between foot 15a and bead 16a is substantially the same as the wall thickness of the double-curve section, provides a relatively tight hinge which, nevertheless, allows relative freedom in the pivotal movement between interlocking panels. Second curvature 18 provides an offset between the pivot joint of the first curvature and bead 16a as to allow interlocking panels to be positioned in parallelism or alternately pivoted into the stop position established by a contact between rib 14 and toe 15b.

In operation, panels 11 are pivotally interlocked by aligning the edge of one panel with a complementary edge of a second, then sliding the rib 14 of one into the pas-

sageway 13 of the other until the panels become positioned in side-by-side relationship. It will be apparent that the accordion-fold pleat is inherently formed by matching alternate ends of the rib-edge with the passageway of the previously connected panel, or vice-versa.

FIG. 5 of the drawings illustrates a modification of the invention wherein each panel 111 is formed with a split rib 114 along one edge, the other edge being formed with a pair of legs 115 and 116 that define a slotted passageway 113. Split rib 114 is formed with a pair of arms 114a and 114b which, in their unstrained "as molded" positions illustrated, cannot pass out through the slotted opening between legs 115 and 116. However, the combined width of arms 114a and 114b is such that when the arms are brought together, rib 114 as a whole may be removed through the slotted opening. It is to be understood, of course, that with such embodiments the panels are to be made of pliable materials which are resiliently flexible to permit arms 114a and 114b to be brought together. Such embodiments, then, provide means for engaging and disengaging the rib of one panel from the slotted passageway of another by a lateral movement as well as a longitudinal sliding movement.

It is also contemplated that the embodiment of FIG. 5 may be utilized to alleviate stresses of binding after surfaces of arms 114a or 114b contact the interior surfaces of passageway 113. Further, it will be seen that after such contacts are made, interconnecting panels may be pivoted against the resilient bias of the material until the arms come together. This relationship provides means for bringing the arms together when, or if, interconnecting panels are to be separated.

What is claimed is:

1. A panel formed of a resilient plastic material and adapted to be used in combination with panels of similar construction to form an accordion-pleated curtain wall, said panel comprising: a sheet-like member having a pair of integrally formed parallel edges, one of said edges defining a slotted passage, the other edge terminating in a rib, said rib being longitudinally split into at least two arms having a combined transverse width when resiliently stressed and brought together which allows said rib to be laterally inserted or retracted from said slotted passage, the two arms having surfaces which are spaced apart a distance greater than said slotted passage when said arms occupy normal unstressed positions, whereby the split rib of one panel may be inserted laterally and locked into the slotted passage of a second panel.

References Cited

UNITED STATES PATENTS

2,641,018	6/1953	Snyder	-----	16—178
2,834,072	5/1958	Miller	-----	160—235 X
3,359,594	12/1967	Pastoor	-----	160—235 X

FOREIGN PATENTS

433,759	8/1935	Great Britain.
931,666	7/1963	Great Britain.
963,770	7/1964	Great Britain.

DAVID J. WILLIAMOWSKY, Primary Examiner

P. C. KANNAN, Assistant Examiner

U.S. Cl. X.R.

160—183, 236