

(19)
(12)

(KR)
(B1)

(51) 。 Int. Cl. ⁷
H01J 17/49

(45)
(11)
(24)

2003 01 24
10 - 0369074
2003 01 09

(21) 10 - 2000 - 0065858
(22) 2000 11 07

(65) 2002 - 0036012
(43) 2002 05 16

(73) 575

(72) 1 858 102 201

(74)

:

(54)

;

;

;

,

,

,

,

;

;

.

2a

1a

1b 1a

,

,

2a

2b 2a

<

1... 2...

3... 4...

5... 6...

7... 8...

9,10...

(Plasma display panel)

가 가

1a

1b 1a

(2) (1), (1) (2),
 (3), (3) (4), (4)
 (5), (1) (6), (7)
 (2) (9,10), (8)
 (8) (4) , R,G,B (Red),
 (Green), (Blue) 1b

(9,10) 가 가 (9,10) (2)
 (5) 가

(9,10) (2) 가
(5) (7) 가

(9,10) 가
가 가

(5) (6)
가 , 가

(white balance) 가
가
가

가 가 ()
가 , 2b , B
G , R

가 (HD TV) 가 3

ITO 가

가

(photomask) 가

(7000K 9300K) .

가

가 가

(57)

1.

;

;

,

;

;

,

,

, ,

;

,

, ,

2.

3.

4.

;

;

;

;

;

;

;

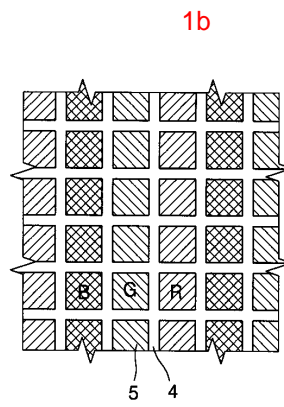
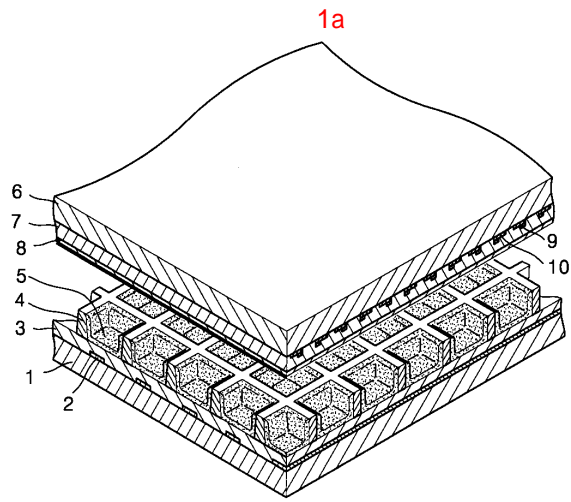

2a

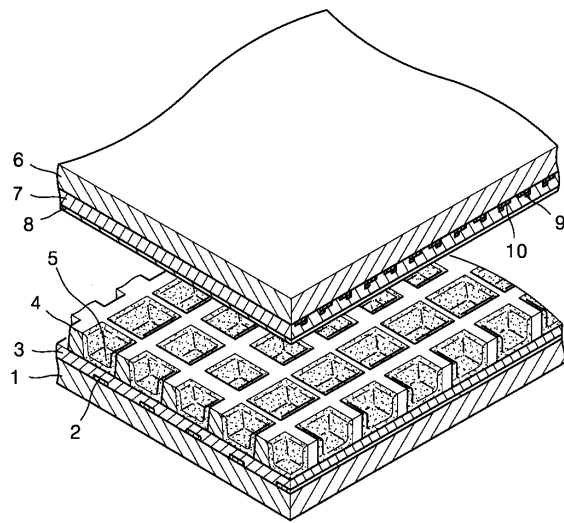

2b

