

(19)  
(12)

(KR)  
(Y1)

(51) 。 Int. Cl.7  
A47G 1/06

(45)  
(11)  
(24)

2004 02 11  
20-0341280  
2004 01 30

(21) 20-2003-0029425 ( )  
(22) 2003 09 17  
(62) 10-2003-0064308  
: 2003 09 17

2003 09 17

(73) 125-8 1

(72) ( ) 503 803

(74)

:

가 :

(54)

;

;

가

가

,

1

2

3a - e

4

10: 20:

21: 30:

31: 40:

41: 50:

가

가

가

가

가

가

가

가

;

;

가

가

가

1

(21)

(10)  
(20)

(20)

가

(31)

(20)

(30)

(30)

(31)

(30)

(30)

3

5

(60)

가

가

(60)

(32)

가

(32)

(20)

(31)

(41)가

(42)

가

(40)

2,3

가 가 가

(41)

가

(50) (20) (21) (31) (41)

(50)

(10) (20), (30) (40)

(41) (10) (20)

(40) (41) 3a (20) (21) (50) (41)

(50)가 가 (41)

(30) (21) 1 (50) (41) 3b (31) (21) (41)

(31) (20) (31) 가 (41)

(50) (20) (41) 3c 2 (31)

3 2 (50) (41) (50) 3d 3e 4

가

(32) 가 (60) (31)

(57)

1.

;

가

가

2.

1

가

3.

1

4.

1

3

5.

1

가

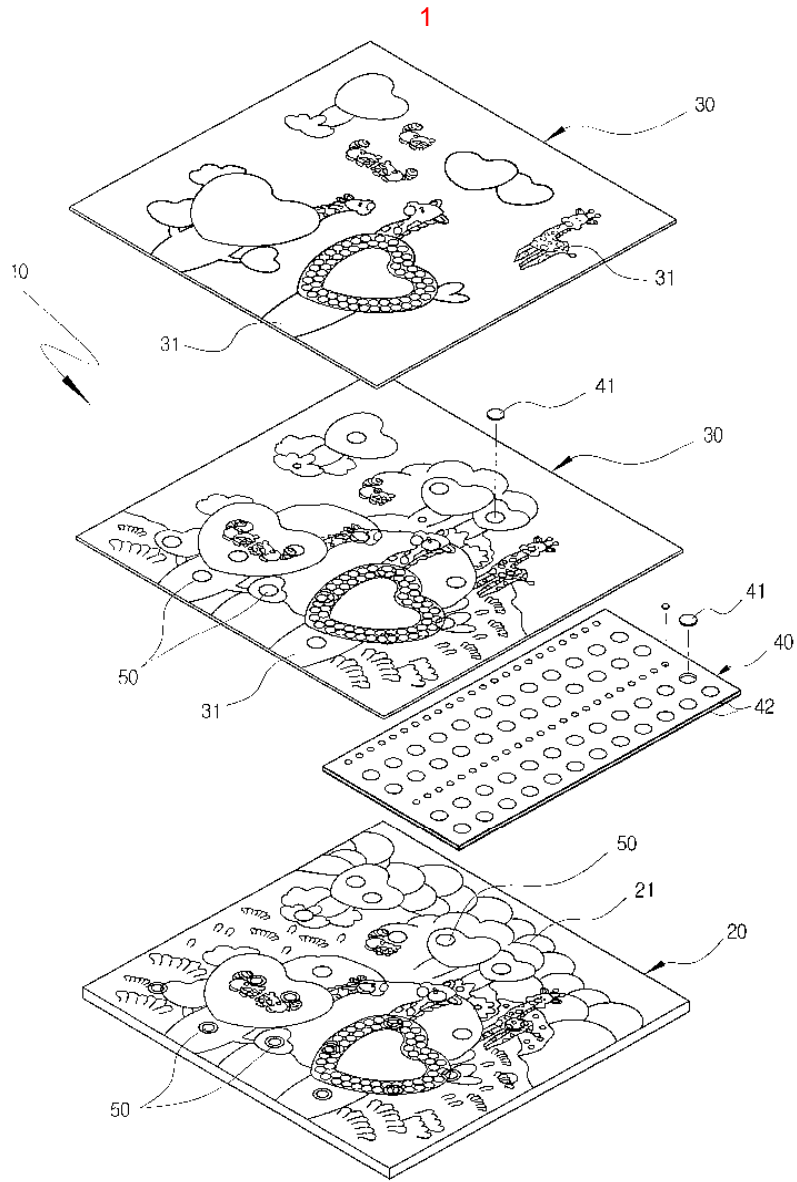

2

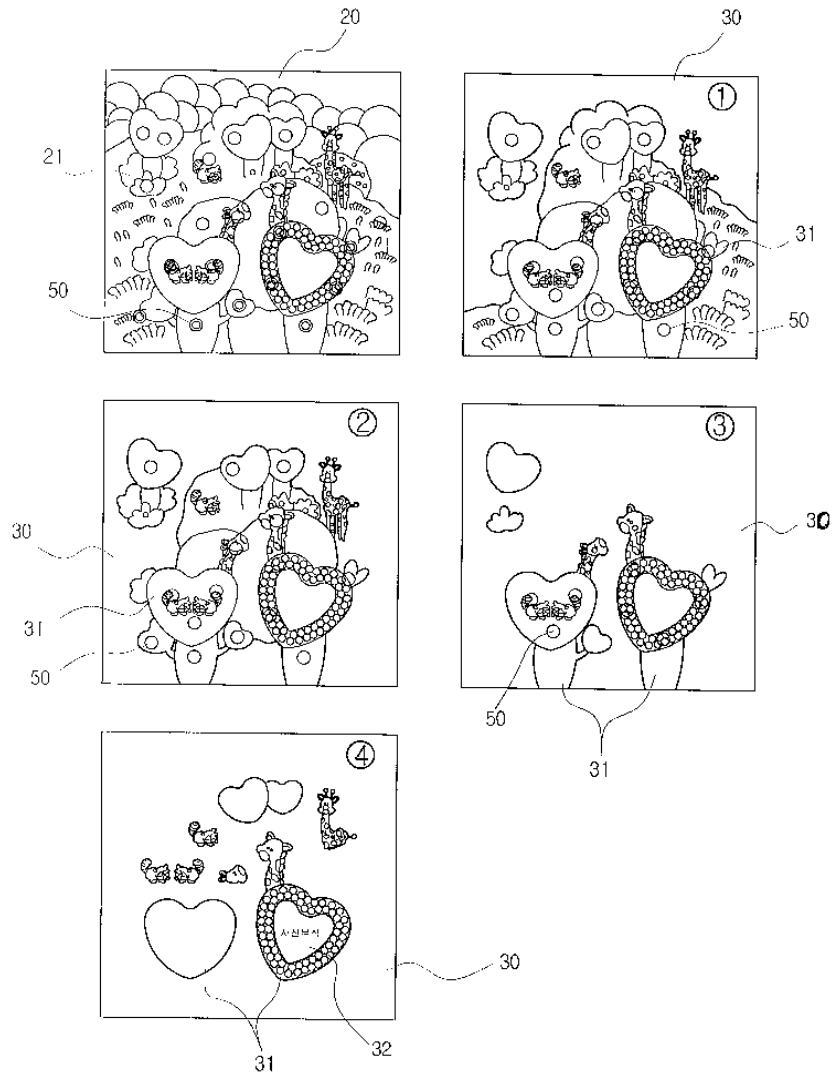

3a

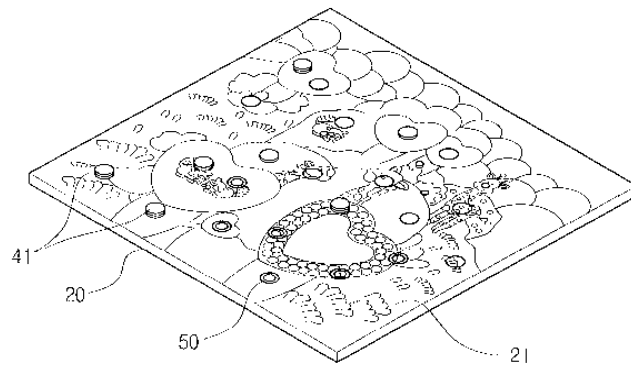

3b

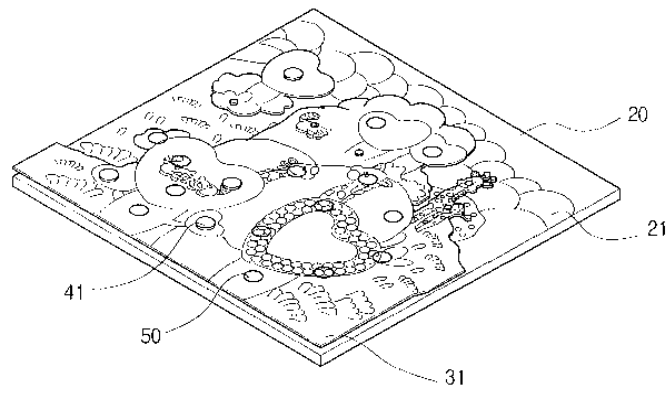

3c

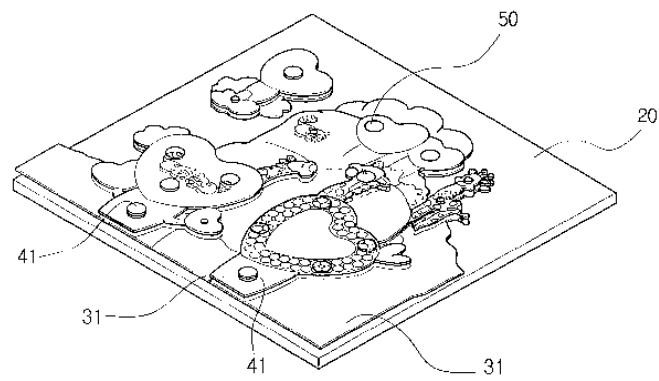

3d

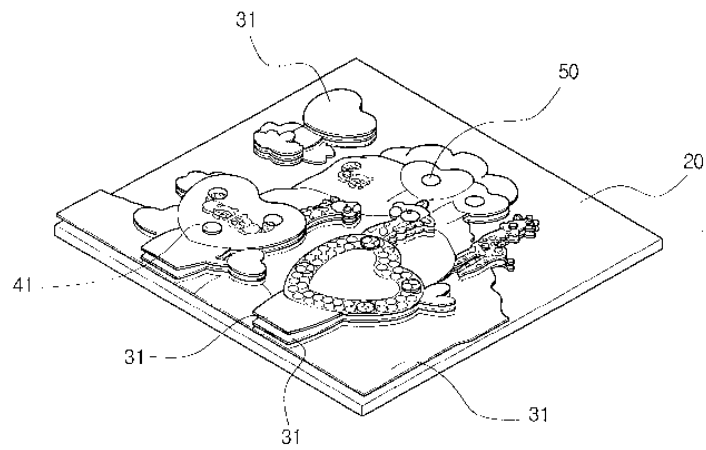



3e

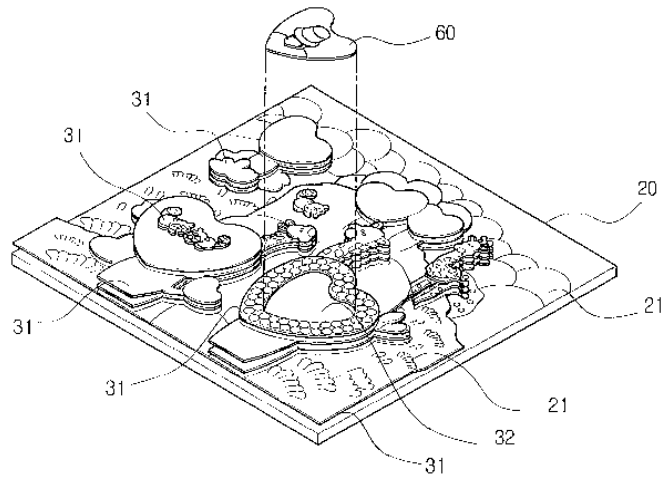

4

