

(12) UK Patent Application (19) GB (11) 2 178 931 A

(43) Application published 25 Feb 1987

(21) Application No 8615286

(22) Date of filing 23 Jun 1986

(30) Priority data

(31) 8515873	(32) 22 Jun 1985	(33) GB
8526279	24 Oct 1985	
8608411	7 Apr 1986	

(71) Applicant  
**Melvyn Wilde,**  
Unit 1A, Empress Industrial Estate, Anderton Street,  
Higher Ince, Wigan

(72) Inventor  
**Melvyn Wilde**

(74) Agent and/or Address for Service  
**Neil Barry, 17 St Ann's Square, Manchester M2 7PW**

(51) INT CL<sup>4</sup>  
A01K 97/10 F16M 11/00

(52) Domestic classification (Edition I):  
A1A 27  
A4L 130 131 ABB

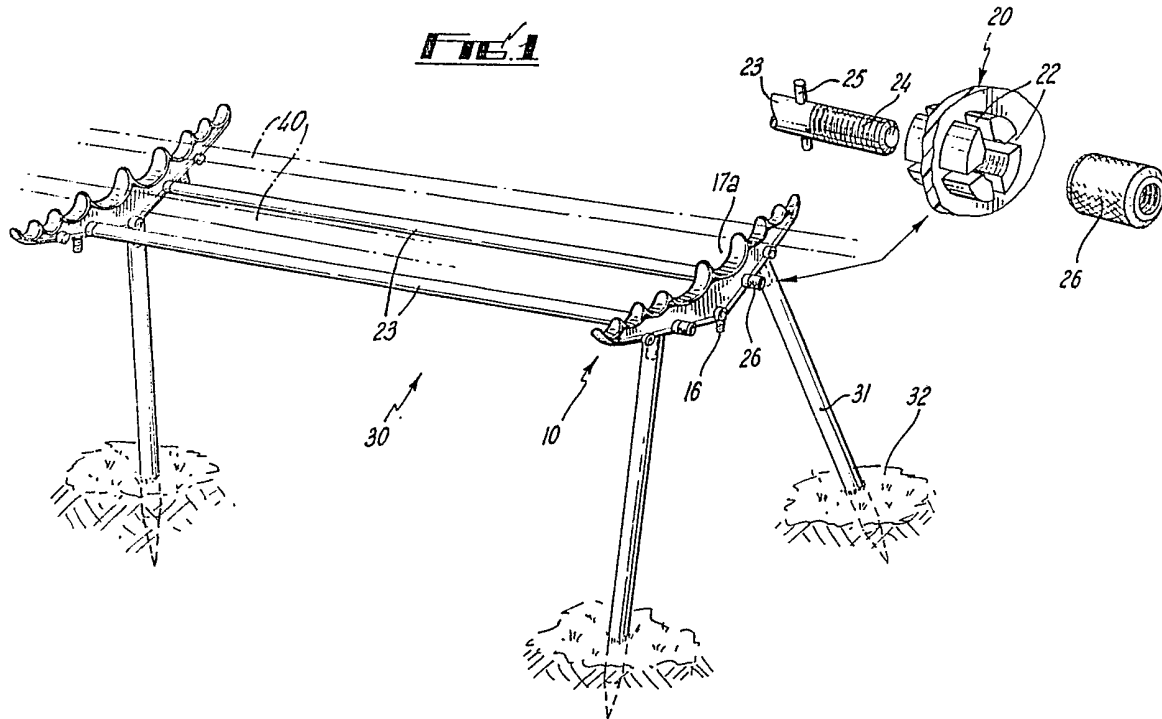
(56) Documents cited

GB A 2129261	GB 0803540
GB A 2123675	GB 0774634
GB A 2058557	GB 0562189
GB A 2048633	US 4245419
GB 1119483	US 3701504

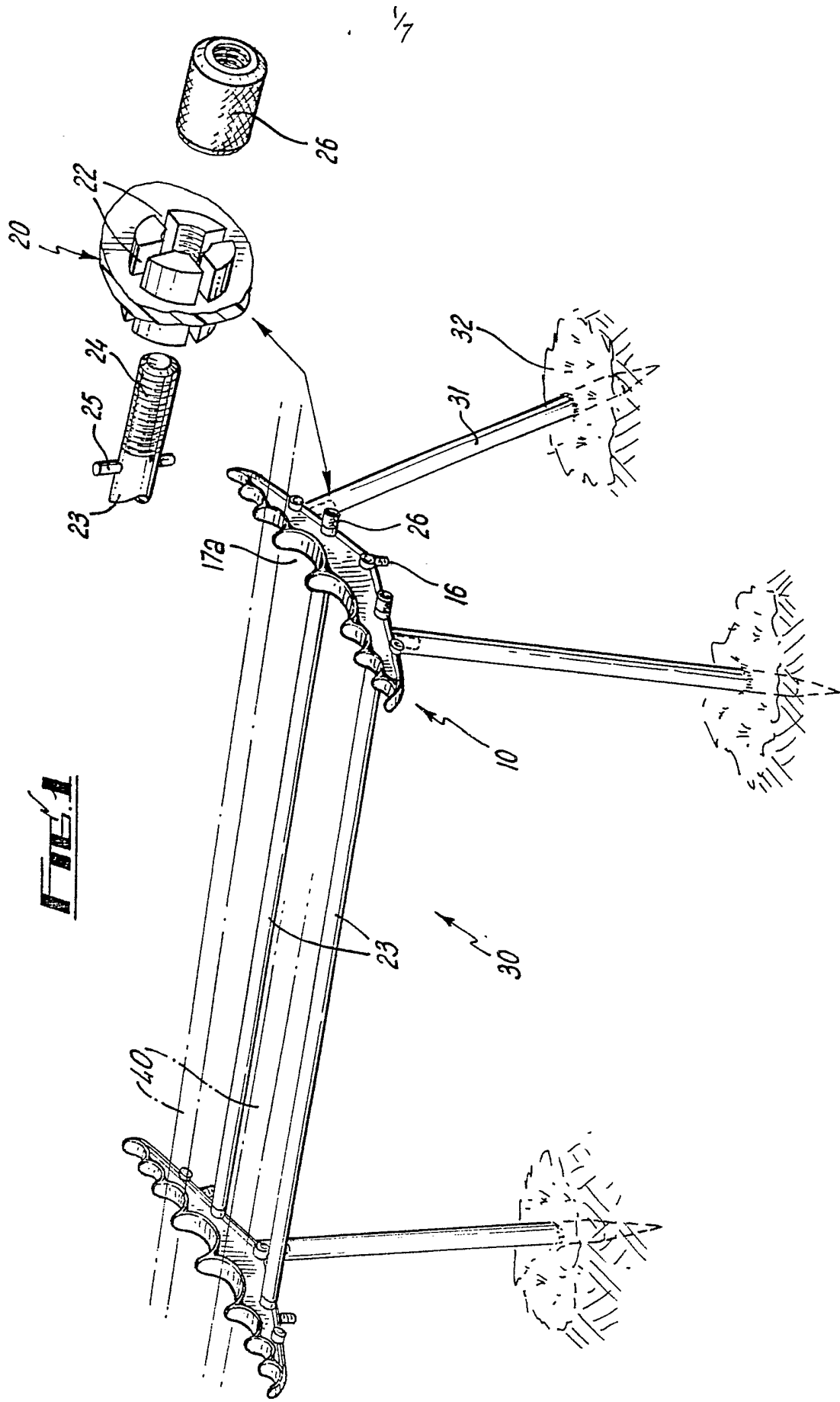
(58) Field of search  
A1A  
A4L  
Selected US specifications from IPC sub-classes A01K  
F16M A47B

(54) Supports

(57) A generally planar support 10 for supporting elongate articles such as fishing poles or pole sections 40 has a number of upwardly facing recesses 17a which differ in size and has threaded bosses 16 for connection to a bank stick or other leg 31 to hold the support above ground 32. Formations 20 have threaded bosses to receive threaded ends of bars 23 having pins 25 received in slots 22 to prevent rotation of the bars. The bars 23 may connect to another support 10 or rest on a wall or the like. The support 10 may be attached to a single leg for sticking into a river bank (Figure 16) or to three legs forming a tripod (Figure 17).

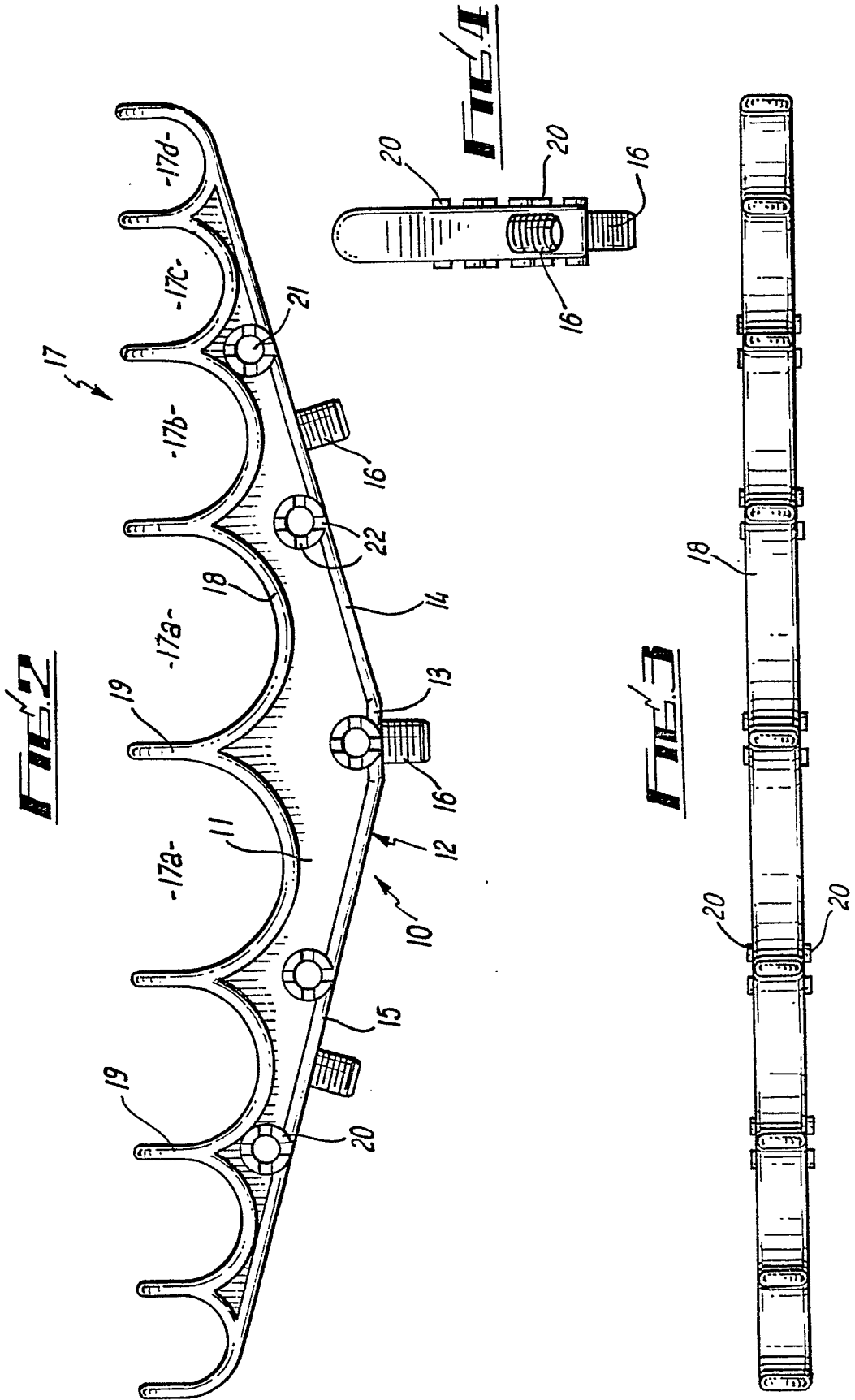


GB 2 178 931 A

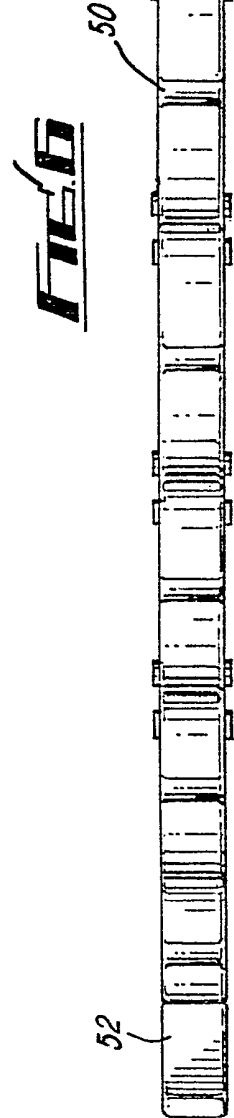
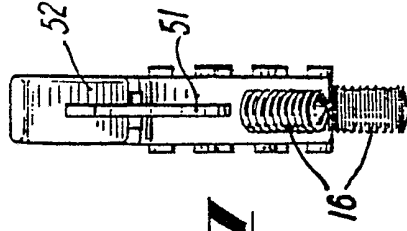
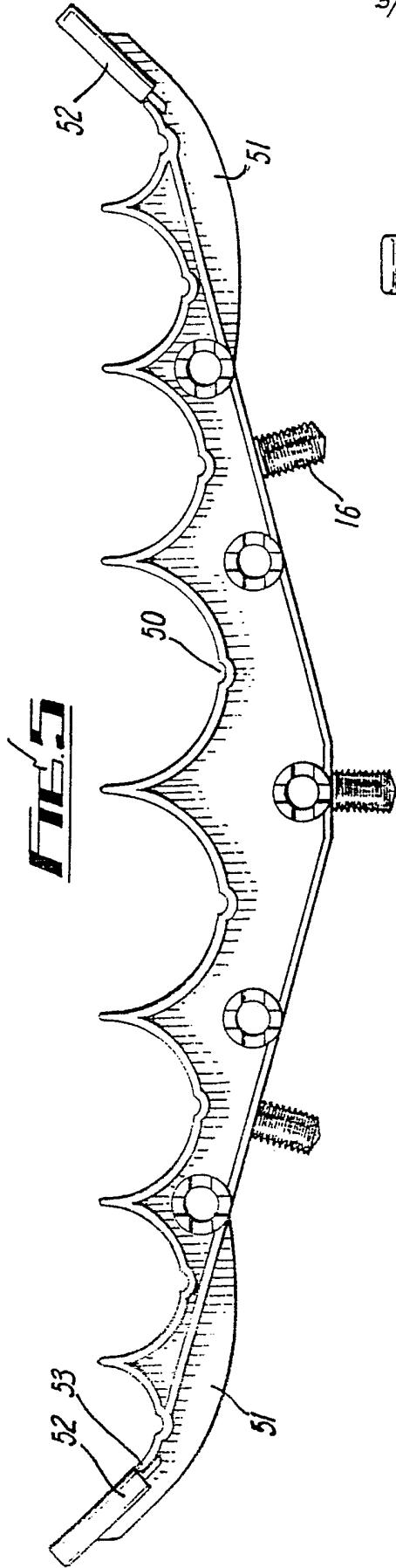


**FIE**

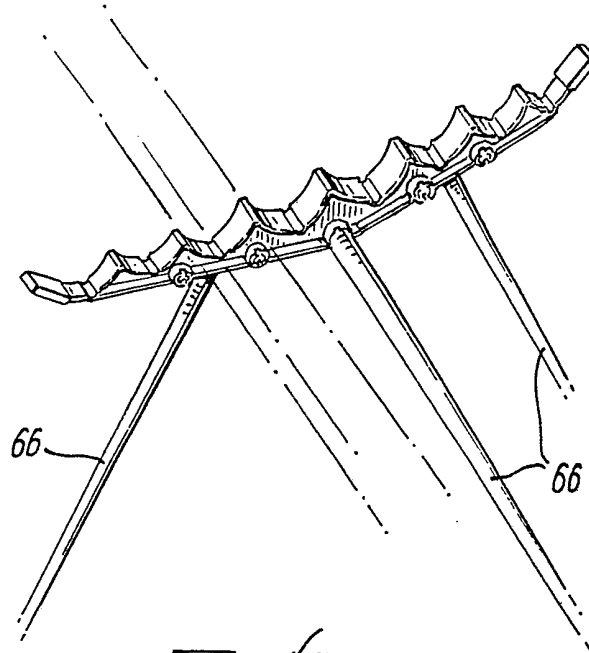
2/7



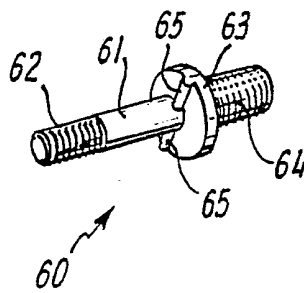
3/7



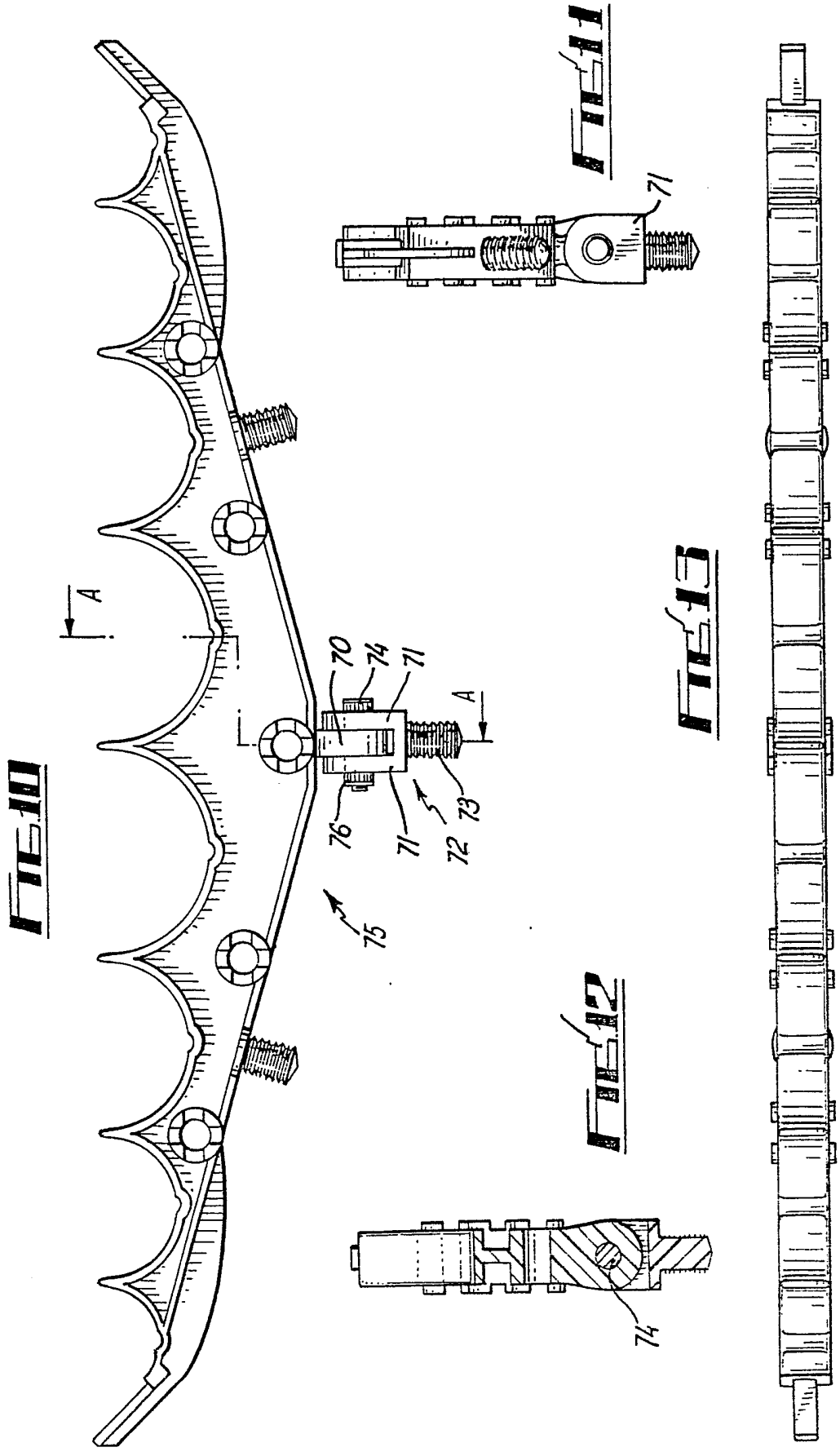
4/7

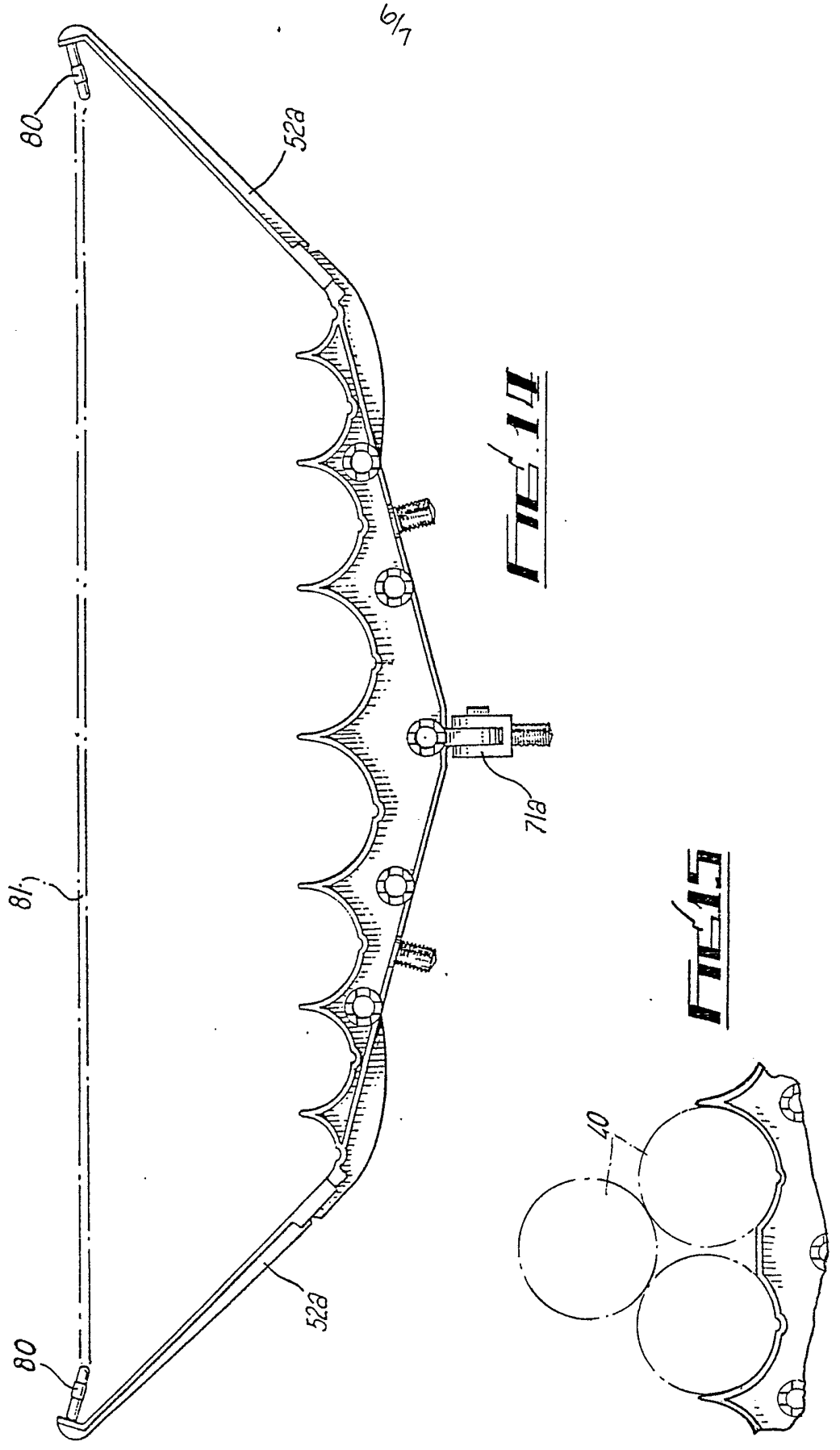


**Fig. 8**

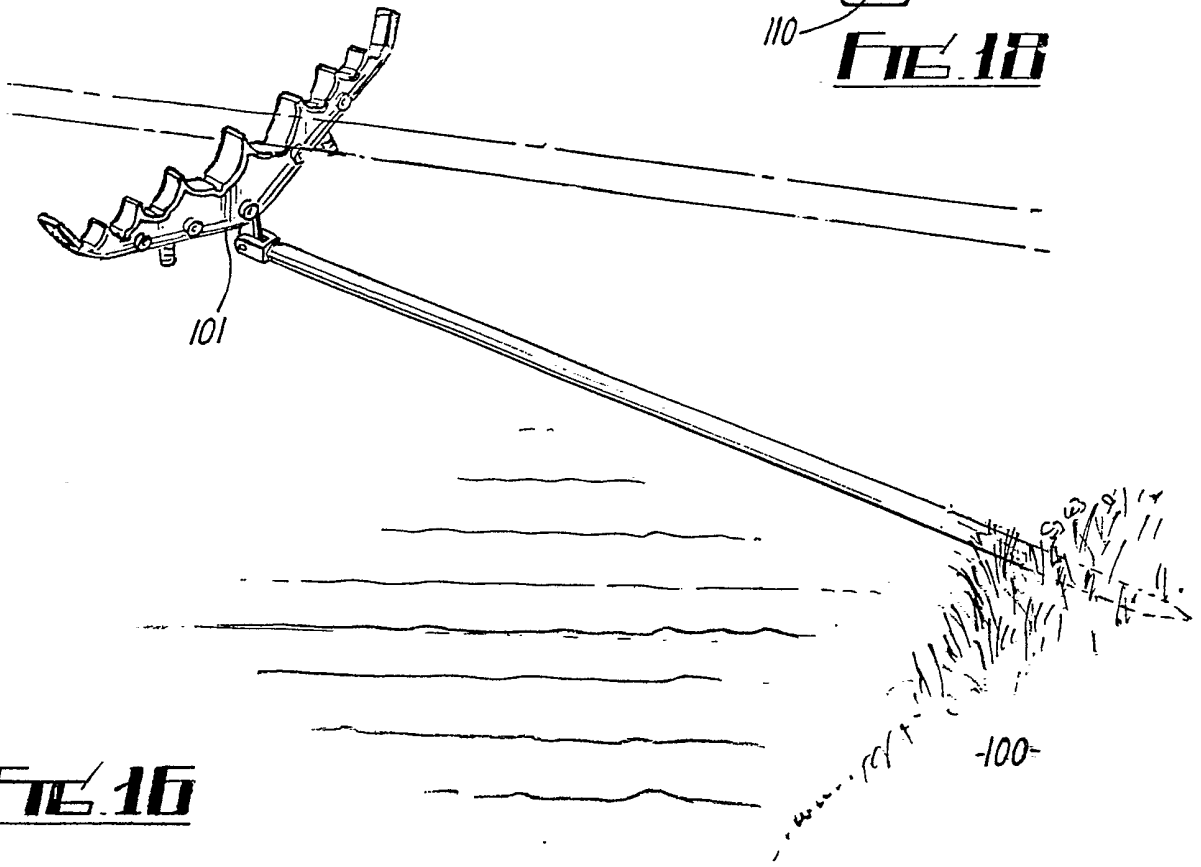
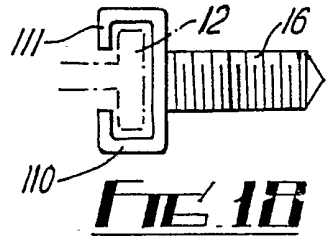


**Fig. 9**

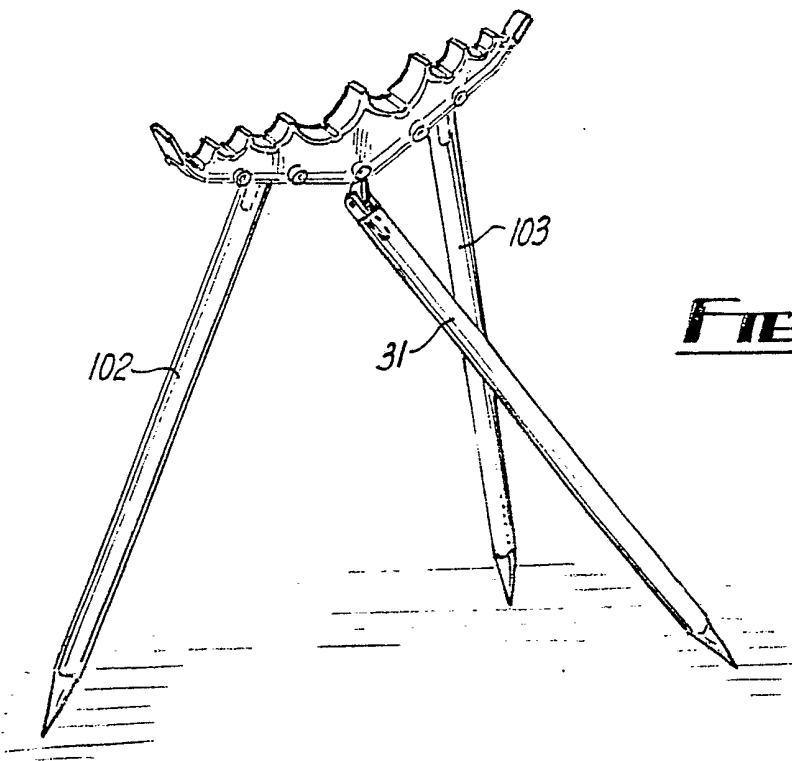




7/7



**FIG. 16**



**FIG. 17**



## SPECIFICATION

**Supports**

5 This invention relates to supports.

According to this invention a support for an elongate article comprises a structure providing a recess for receiving an elongate article, means engageable with a leg for holding the support above a surface, and means for receiving and holding an elongate element extending from the structure.

The structure may be generally planar.

The structure may provide upper and lower edges, the upper edge providing a plurality of said recesses.

15 At least some of the recesses may be of different sizes. Successive recesses may decrease in size as they extend away from a central region of the structure.

The recesses may have substantially part-circular bases.

20 The means engageable with a leg may comprise a threaded boss. There may be several such bosses inclined with respect to each other.

There may be a plurality of said receiving and holding means. The or each means for receiving may be adapted to hold an elongate element extending in either of two opposed directions from the structure.

25 The or each means for receiving and holding may comprise a boss having a through bore. The boss may have one or more slots for receiving one or more pins on the elongate element for resisting relative rotation between the structure and the elongate element.

The through bore may be internally threaded for engagement with a threaded part of the elongate element.

35 The support may have one or more said legs attached thereto.

The means engageable with a leg may comprise a coupling permitting angular adjustment of the support relative to the leg. The coupling may comprise a pivot.

40 The support may comprise elements extending laterally on each end, each element providing an inwardly directed nipple for receipt of a flexible elongate means extending between the nipples.

45 A support assembly may comprise a said support and one or more elongate elements held by said receiving means.

The assembly may comprise two said supports connected by one or more said elongate elements.

The invention includes a support however defined.

50 The invention may be performed in various ways and several specific embodiments with possible modifications will now be described by way of example with reference to the accompanying drawings, in which:

55 *Figure 1* is a perspective view of a support or bracket assembly;

*Figure 2* is a side view of a support;

*Figure 3* is a plan view of *Figure 2*;

*Figure 4* is a view from the left of *Figure 2*;

60 *Figures 5 to 7* are views similar to *Figures 2 to 4* of another arrangement;

*Figure 8* is another perspective view;

*Figure 9* shows a coupling element;

*Figure 10* is a side view of another support;

65 *Figure 11* is an end view of *Figure 10*;

*Figure 12* is a section on the line A-A of *Figure 10*;

*Figure 13* is a plan view of *Figure 10*;

*Figure 14* is a side view of another support;

*Figure 15* is a side view of a further support;

70 *Figure 16* shows use of a support;

*Figure 17* shows a further use; and

*Figure 18* shows a modification.

A support 10 may be moulded from plastics and is generally planar and in the form of a central flat web 11 having a peripheral flange 12 extending to both sides of the web. At the lower edge the flange diverges uniformly upwards at 14, 15 as it extends outwards from a central portion 13. Midway along each of portions 13, 14, 15 and at right angles respectively thereto are externally threaded bosses 16.

80 The flange along the top of the web is shaped to provide a number of U-shaped recesses 17 providing flat support surfaces 18. The bases of the recesses are part-circular and in the embodiment shown there are four recesses on each side of a central arm 19 of the central recesses, successive recesses 17a, 17b, 17c, 17d being of reduced size as they approach the ends of the top.

85 The whole support is symmetrical about a central vertical cross section.

90 Vertically beneath the arms 19 between recess 17a, 17a; 17a, 17b; 17b, 17c and adjacent the lower flange the support is formed with a respective boss 20 extending on both sides of the web and having a threaded through bore 21, the outer faces of the bosses being formed with two orthogonal diametral slots 22.

95 In use, the bores 21 receive elongate rigid bars 23 which have threaded ends 24 and two diametrically extending pins 25. The ends 24 are inserted into bores 21 of two supports 10 and are held by nuts 26, the pins 25 being received in two of the slots 22 to resist rotation of the bar and provide a firm support assembly 30.

100 The bosses 16 are threaded into apertures in the tops of support legs 31 to hold the assembly 30 above, for example, the ground 32. Each leg 31 may be a so-called bank stick as used by fishermen. Because the outer bosses 16 are inclined to each other and the central boss 16, they provide an additional support. Thus as shown in *Figure 1*, one support 10 may have a central leg 31 and the other support two lateral, inclined legs to give a three point support. The legs need not be vertical. One support 10 could be omitted and the free ends of bars 23 be rested on a wall or the like.

105 Also, because the bars can be engaged with bosses 20 from either side of the web, some bars 23 may extend in one direction from the web and other bars in the opposite direction so that more than two supports 10 can be assembled together by bars 23.

110 When used by fishermen the assembly 30 *Figure 1* can be used to support disassembled lengths 40 of a fishing pole, which is normally tapered so that successive lengths have different cross-sections and may conveniently be placed in different ones of the recesses 17. This keeps the pole lengths away from the ground and possible dirtying therefrom and readily available. Other elongate articles can however be supported by the assembly of support and bars. For

130

example the support 10 can be used to support a pole when in use.

The number and size and shapes of the recesses 17 can be varied as also the number, shape and dis-  
5 position of bosses 16 or 20.

The through bores 21 need not be threaded.

The embodiment of Figures 5 to 7 is generally similar to Figures 2 to 4 but the shape and relative sizes of recesses 17a—17d are different, and the base  
10 of each recess is provided with a groove 50 for receipt of a fishing line. Also the underside flange is provided with a central flat depending rib 51 at its outer end which projects beyond the top flange 12 and in the  
15 outer region is of T-section to slidably receive a slotted channel member 52. The member 52 may be of a different colour (e.g. red) to the remainder of the support (e.g. green) to provide a ready visual indication of the ends of the support.

The outer walls 53 of the outer recesses 17d are cut  
20 short as compared with Figure 2.

There may also be provided a coupling element 60 Figure 9 which has a stem 61 threaded at its end 62 and having a central part 63 from the other side of which extends a threaded boss 64 similar to bosses  
25 16. The face of part 63 facing stem 61 has radial projections 65 which can enter into slots 22 so that stem 61 can be inserted in the central boss 20, the thread 62 receiving a nut to secure the element in position, the projections 65 preventing rotation. A  
30 bank stick can then be secured to boss 64 so that the support can be provided with three support legs 66 attached to boss 64 and outer bosses 16 so that the support can be supported, e.g. on concrete, on the three legs.

A further arrangement 75 shown in Figures 10 – 13  
35 is similar to Figure 5 and may have members 52 (not shown) which could be fluorescent. In this case the central boss 16 is formed as a flat-sided apertured depending lug 70 which is closely received between  
40 the flat apertured sides 71 of a U-bracket 72 from which depends a boss 73 similar to boss 16. A bolt 74 extends through the apertures in lug 70 and sides 71 and receives a nut 76 so that the support 75 can be pivoted about the bolt 74 with respect to the boss 73,  
45 and thus relative to the bank stick or support leg which may be attached thereto as above. The bolt and nut may be released and re-engaged to hold the support 75 releasably in the various positions of adjustment.

In the further arrangement shown in Figure 14,  
50 similar to Figure 10, the nut 76 (not shown in Figure 14) is located in a hexagonal recess in the respective side 71a. Also detachable members 52a are similar to members 52 but are longer and each has an inwardly directed nipple 80 for releasably receiving, for example,  
55 a flexible rubber tube 81 on which a pole or rod may be rested during use. The length 81 may be curved (concave facing upwards).

In Figure 15 the centre arm 19 is reduced in height enabling a third length of pole to be rested on two  
60 lengths themselves resting in the two centre recesses.

Figure 16 shows use of support 10 during fishing with pole or rod resting on the support and a central leg secured in the bank 100 and pivotally connected at  
101 to the centre of the support.

65 Figure 17 illustrates how, using the pivotal central

leg 31, and two side legs 102, 103 connected to bosses 16, a three-point support for the support 10; this can be used when the legs cannot be pushed into the ground, e.g. if the legs engage concrete. The lower  
70 ends of the leg or legs need not be pointed.

In a modification one or both of the lateral bosses 16 are pivotally connected to the flange 12 in a similar manner to the central leg so that each leg can be independently adjusted to either side of the plane of  
75 support 10.

In a further modification any one or more or all of the bosses 16, 73 are connected to the web 11 in a manner additionally permitting angular movement in the plane of the web 11.

80 In further modification of any of the above embodiments any one or more or all the bosses 16, 73 are detachably mounted on flange 12 so as to be adjustable laterally therealong. For example the bosses 16 or lug 70 may be formed with a channel-shaped  
85 element having limbs 110 which can be sprung apart to receive and closely embrace the flange 12 and inturned ends 111 which lie over the sides of the flange and have sufficient resilience to hold firmly the boss or lug to the flange but permit adjustment therealong.

## 90 CLAIMS

1. A support for an elongate article comprising structure providing a recess for receiving an elongate  
95 article, means engageable with a leg for holding the support above a surface, and means for receiving and holding an elongate element extending from the structure.
2. A support as claimed in Claim 1 which is generally planar.
3. A support as claimed in Claim 1 or Claim 2, providing upper and lower edges, the upper edge providing a plurality of said recesses.
4. A support as claimed in Claim 3, in which at  
100 least some of the recesses are of different sizes.
5. A support as claimed in Claim 4, in which successive recesses may decrease in size as they extend away from a central region of the structure.
6. A support as claimed in any of Claims 3 to 5, in  
105 which the recesses have substantially part-circular bases.
7. A support as claimed in any preceding claim, in which the means engageable with a leg comprises a threaded boss.
8. A support as claimed in any preceding claim, including a plurality of said engageable means respec-  
110 tively for legs inclined to each other.
9. A support as claimed in any preceding claim, comprising a plurality of said receiving and holding means.
10. A support as claimed in any preceding claim, in  
115 which the or each means for receiving and holding comprises a boss having a through bore.
11. A support as claimed in Claim 10, in which the boss has one or more slots for receiving one or more  
120 pins on the elongate element for resisting relative rotation between the structure and the elongate element.
12. A support as claimed in Claim 10 or Claim 11,  
130 in which the or each through bore is internally

threaded for engagement with a threaded part of the elongate element.

13. A support as claimed in any preceding claim, comprising elements extending laterally on each end of the support, each element providing an inwardly directed nipple for receipt of a flexible elongate means extending between the nipples.

14. A support as claimed in Claim 1, said receiving means being adapted to hold the elongate element in a manner resisting rotation of the elongate element.

15. A support as claimed in any preceding claim having a plurality of said engageable means.

16. A support as claimed in any preceding claim, in which the means engageable with a leg comprises a coupling permitting angular adjustment of the leg relative to the support.

17. A support as claimed in Claim 16, in which the coupling comprises a pivot.

18. A support as claimed in any preceding claim, including a leg engaged with the or each engageable means.

19. A support as claimed in any preceding claim, in which the engageable means is adjustable laterally of the support.

20. A support for an elongate article substantially as hereinbefore described with reference to and as illustrated in Figure 1 or Figures 2 to 4, or Figures 5 to 7, or Figure 8, or Figures 10 to 13, or Figure 14, of the accompanying drawings.

21. A support assembly comprising a support as claimed in any preceding claim and one or more elongate elements held by said receiving means.

22. A support assembly as claimed in Claim 21, comprising two said supports connected by one or more said elongate elements.