

[54] TELESCOPIC MATERIAL HANDLING VEHICLE

[75] Inventors: Dale D. Sandrock, Pekin, Ill.; Stephen H. Gill, Mentor; Llewellyn L. Walter, Chardon, both of Ohio; David P. Brown, Osmotherly; James Wilson, Sunderland, both of United Kingdom

[73] Assignee: Caterpillar Industrial Inc., Mentor, Ohio

[**] Term: 14 Years

[21] Appl. No.: 187,784

[22] Filed: Apr. 29, 1988

[52] U.S. Cl. D34/37

[58] Field of Search D34/37, 34, 28; 180/89.14, 89.17, 89.18, 89.12; 280/5.3; 414/785, 607

[56] References Cited

U.S. PATENT DOCUMENTS

4,076,302	2/1978	Sable	180/89.14
4,239,446	12/1980	Vucinic	414/785
4,392,669	7/1983	Martin, Jr.	180/89.12
4,688,981	8/1987	Raunborg et al.	414/607
4,750,752	6/1988	Furuta	D34/37

Primary Examiner—Kay H. Chin

Attorney, Agent, or Firm—Alan J. Hickman

[57] CLAIM

The ornamental design for a telescopic material handling vehicle, as shown and described.

DESCRIPTION

FIG. 1 is a top and front perspective view of a telescopic material handling vehicle showing our new design;

FIG. 2 is a right side elevational view thereof;

FIG. 3 is a left side elevational view thereof;

FIG. 4 is a front elevational view thereof;

FIG. 5 is a rear elevational view thereof;

FIG. 6 is a top plan view thereof;

FIG. 7 is a bottom plan view thereof; and

FIG. 8 is a bottom perspective view thereof.

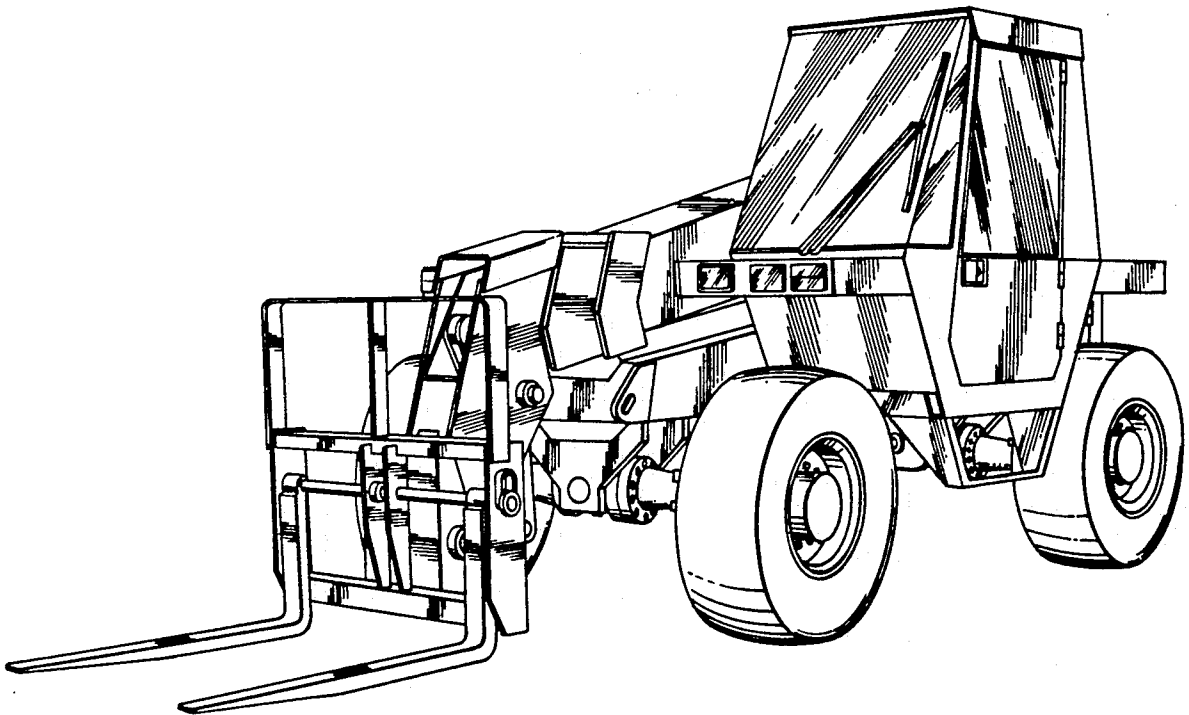

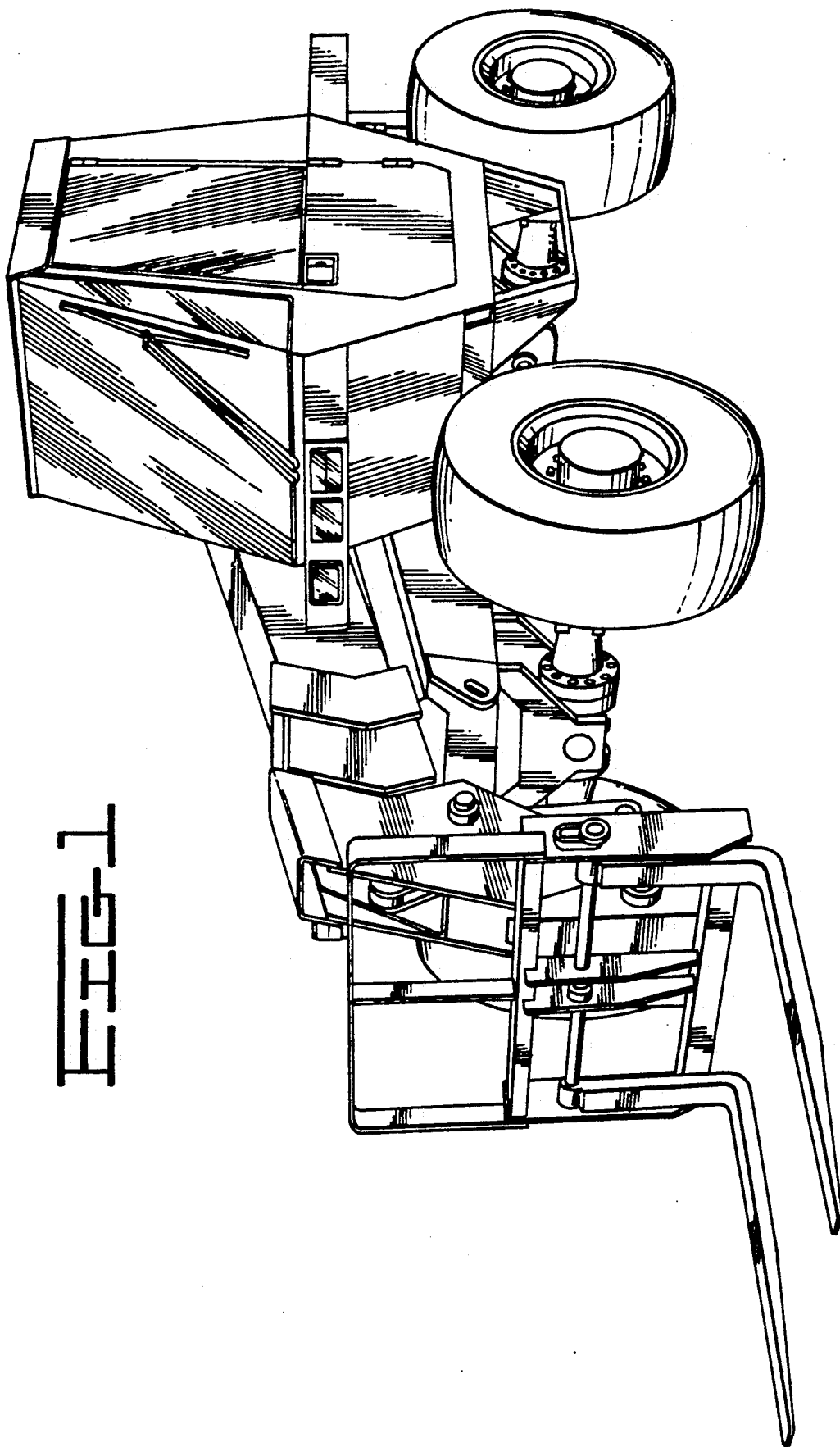
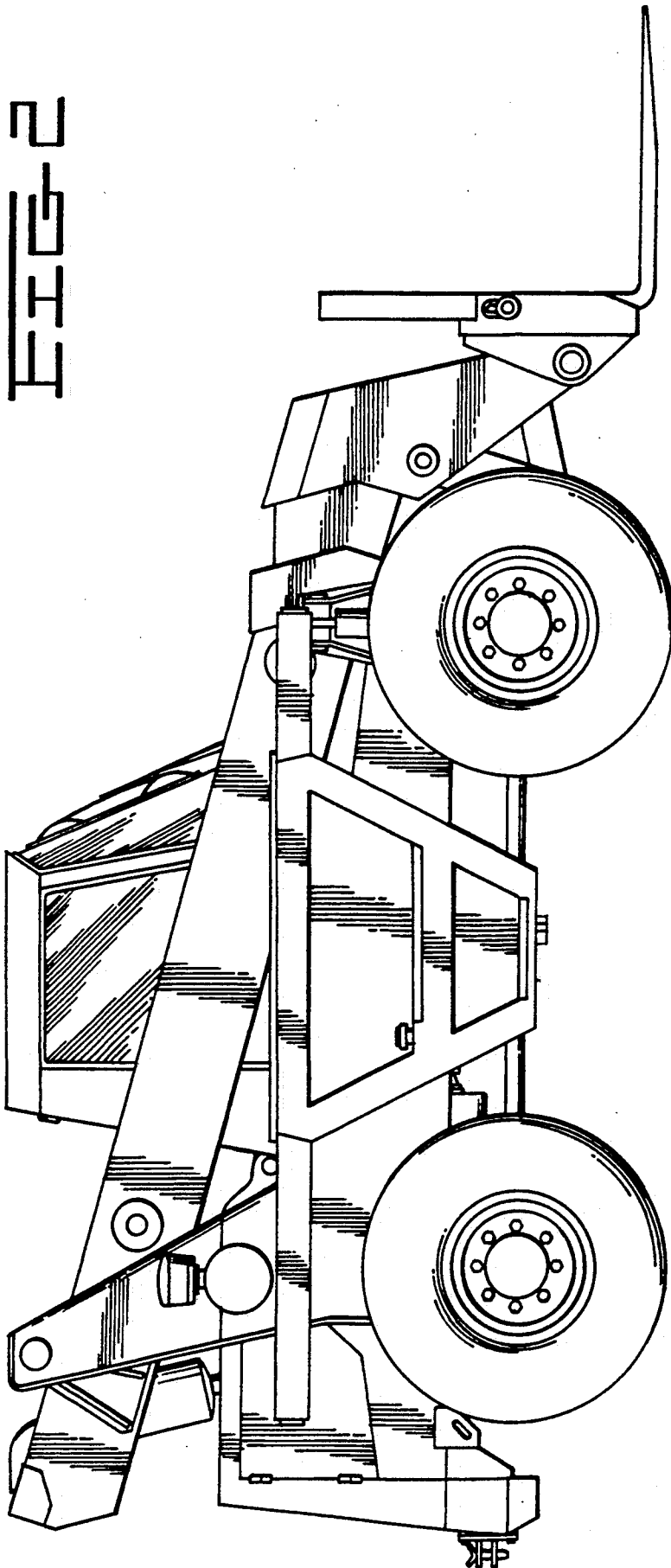

FIG. 1



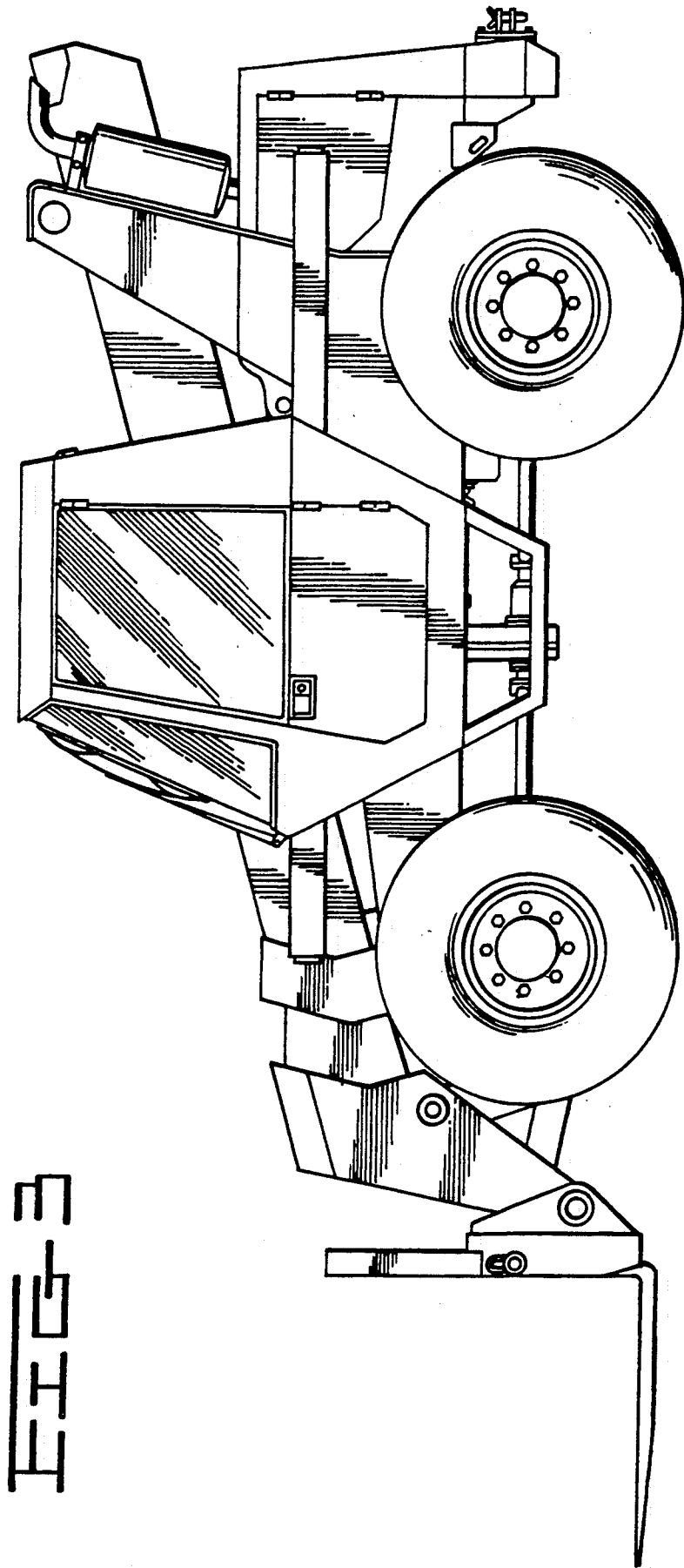

FIG. 3

FIG 4

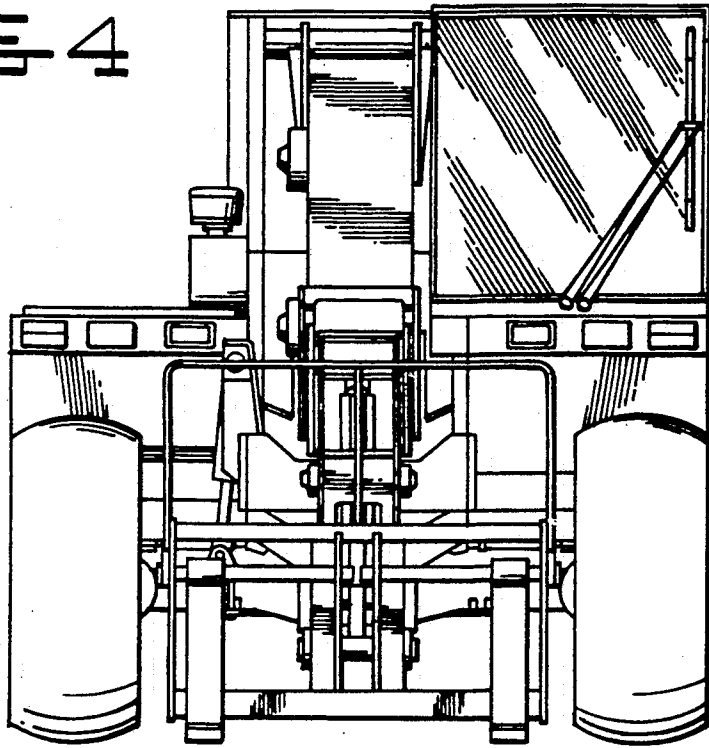
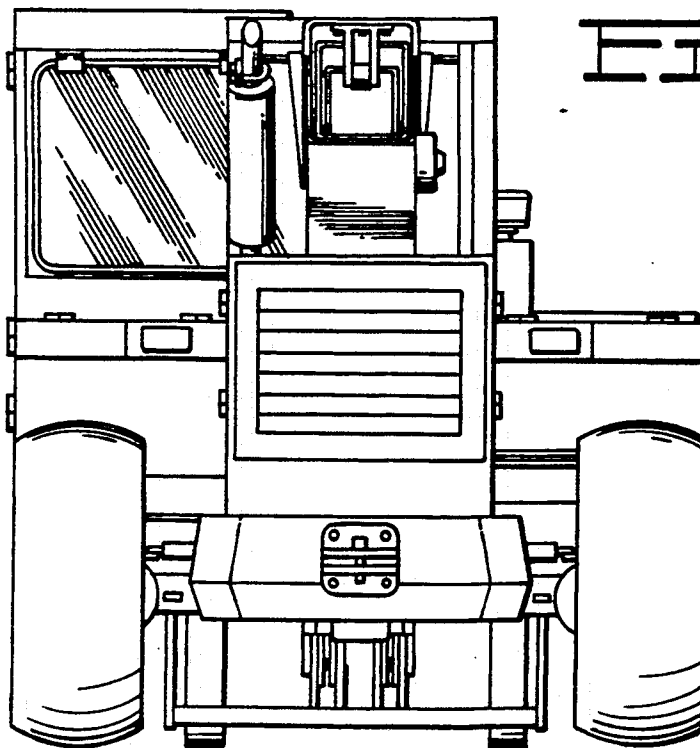
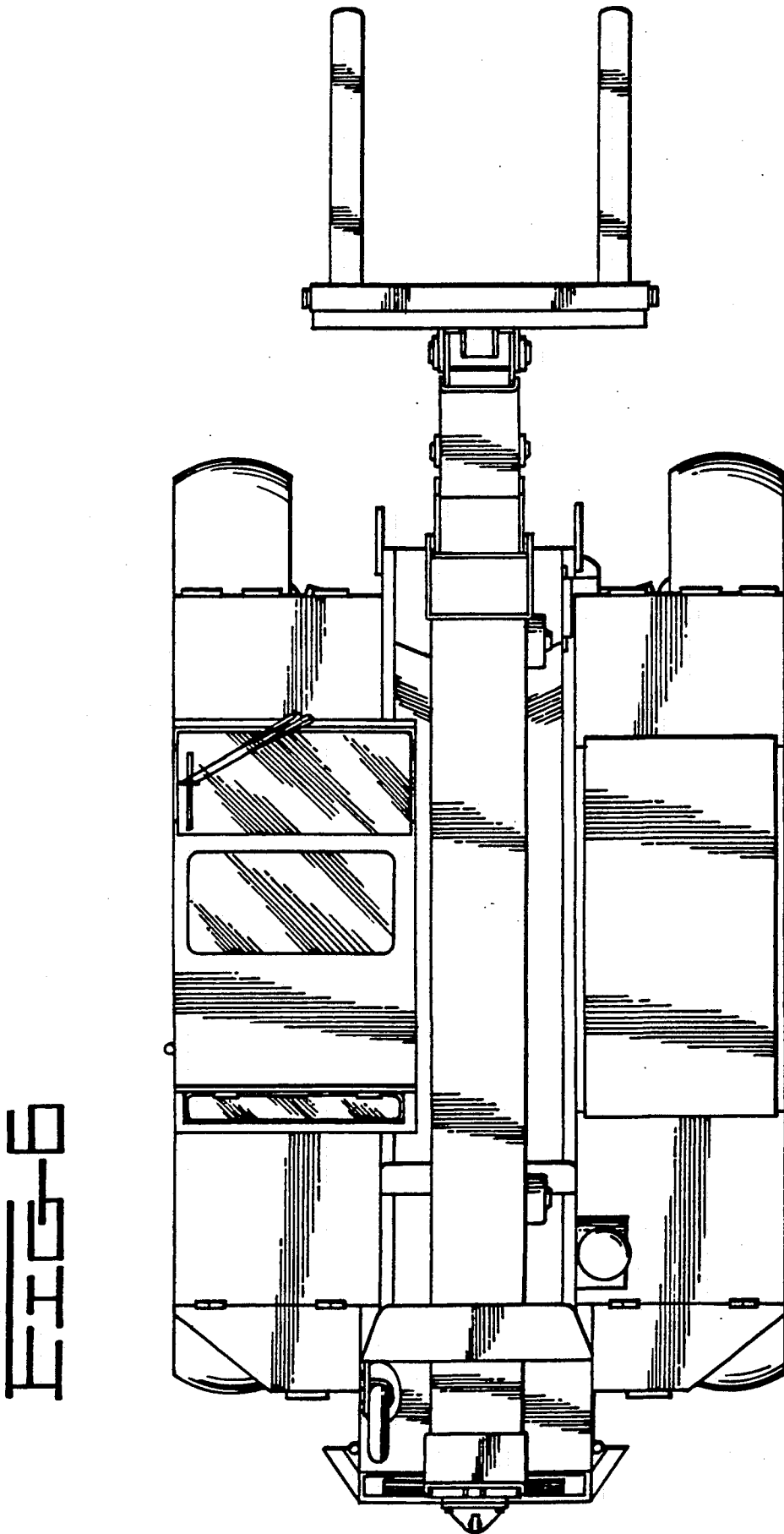

FIG 5





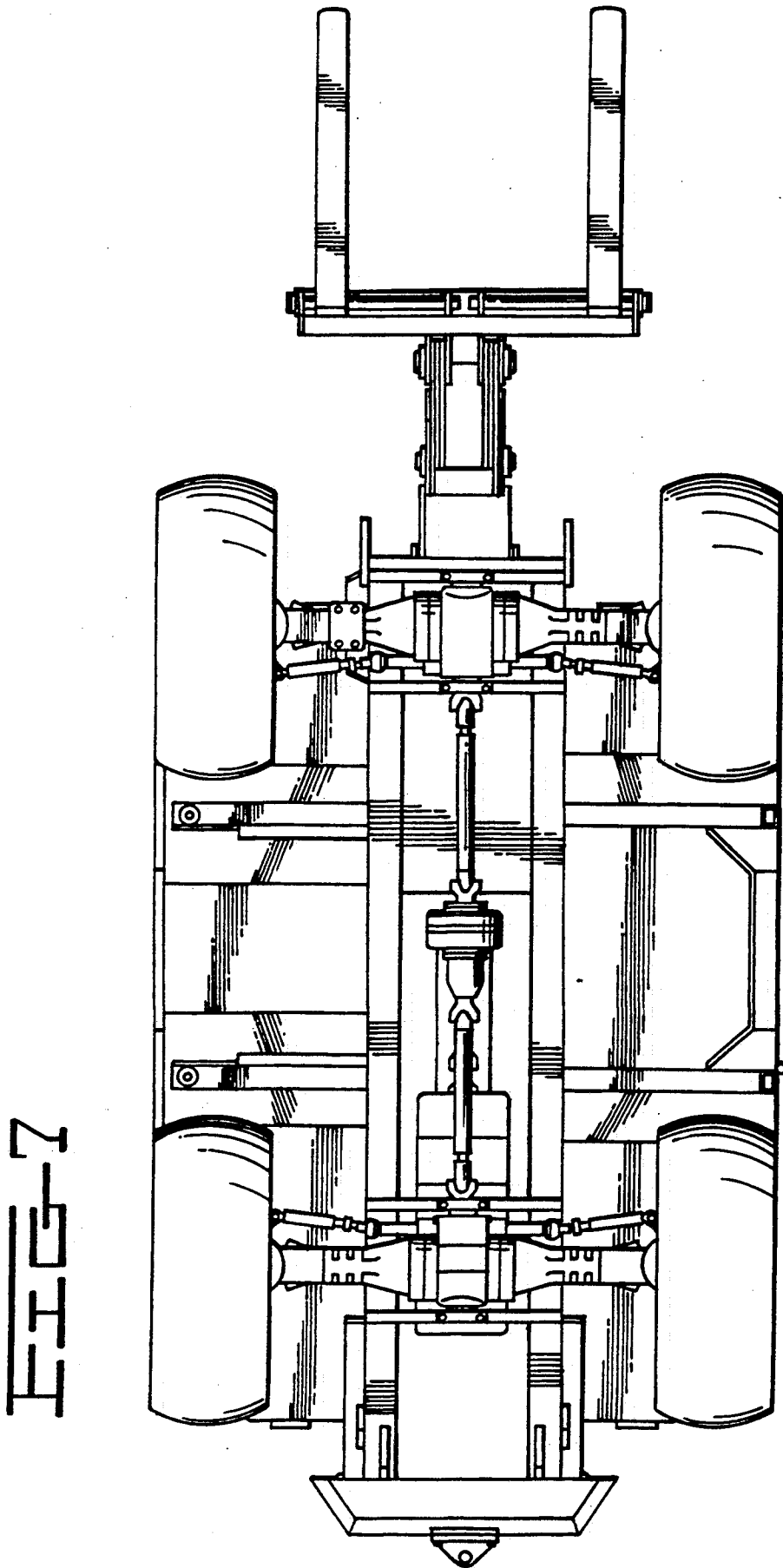
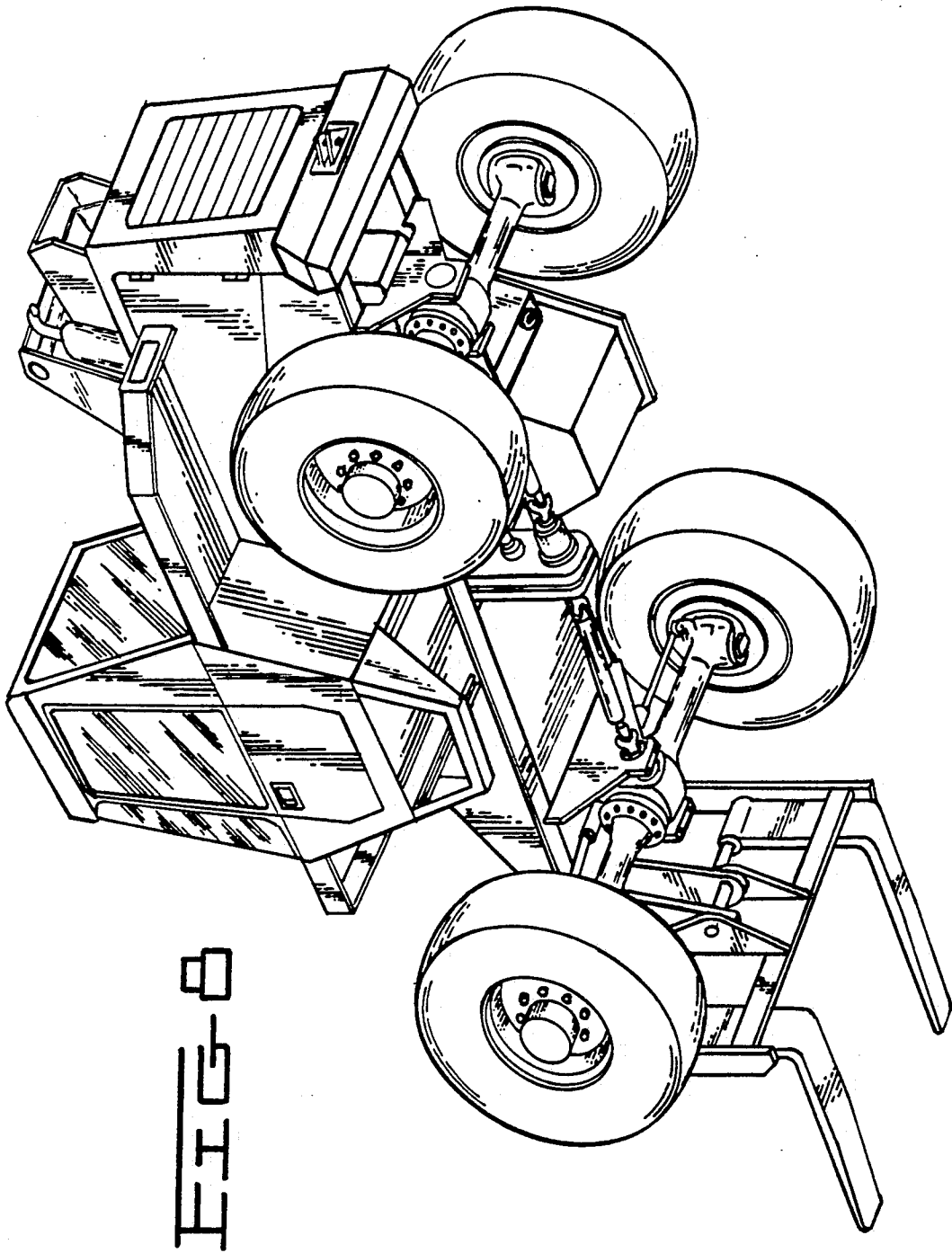

FIG. 7



EIG-8