

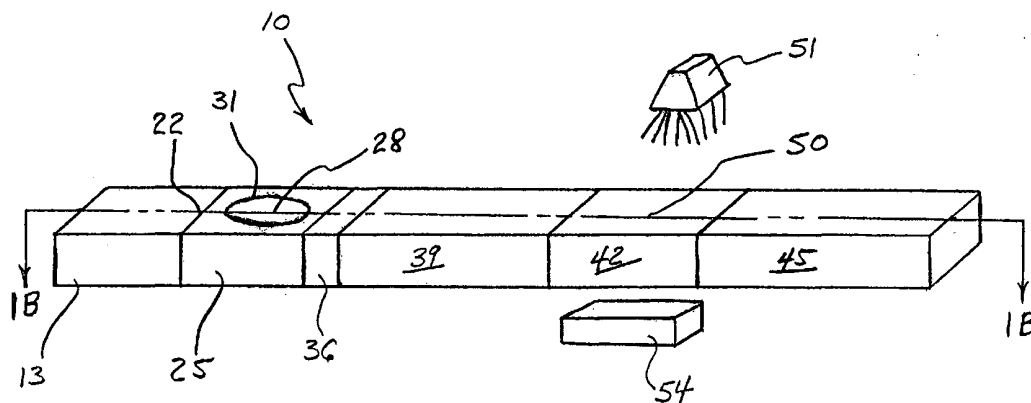

INTERNATIONAL APPLICATION PUBLISHED UNDER THE PATENT COOPERATION TREATY (PCT)

<p>(51) International Patent Classification ⁷ : G01N 31/22, 21/29, 21/41, 15/06, 33/48</p>	<p>A1</p>	<p>(11) International Publication Number: WO 00/50891 (43) International Publication Date: 31 August 2000 (31.08.00)</p>
<p>(21) International Application Number: PCT/US00/05038 (22) International Filing Date: 25 February 2000 (25.02.00) (30) Priority Data: 60/122,140 26 February 1999 (26.02.99) US (71) Applicant: FERTILITY ACOUSTICS INC. [US/US]; 836 Main Street, Buffalo, NY 14202 (US). (72) Inventors: MCNIERNEY, John, C.; 405 Dix-Lee-On Drive, Fairburn, GE 30213 (US). GIBBONS, William, S., Jr.; 28 Temple Place, East Aurora, NY 14052 (US). (74) Agents: LINIHAN, Martin, G. et al.; Hodgson, Russ, Andrews, Woods & Goodyear, LLP, Suite 2000, One M & T Plaza, Buffalo, NY 14203-2391 (US).</p>	<p>(81) Designated States: AE, AL, AM, AT, AU, AZ, BA, BB, BG, BR, BY, CA, CH, CN, CR, CU, CZ, DE, DK, DM, EE, ES, FI, GB, GD, GE, GH, GM, HR, HU, ID, IL, IN, IS, JP, KE, KG, KP, KR, KZ, LC, LK, LR, LS, LT, LU, LV, MA, MD, MG, MK, MN, MW, MX, NO, NZ, PL, PT, RO, RU, SD, SE, SG, SI, SK, SL, TJ, TM, TR, TT, TZ, UA, UG, UZ, VN, YU, ZA, ZW, ARIPO patent (GH, GM, KE, LS, MW, SD, SL, SZ, TZ, UG, ZW), Eurasian patent (AM, AZ, BY, KG, KZ, MD, RU, TJ, TM), European patent (AT, BE, CH, CY, DE, DK, ES, FI, FR, GB, GR, IE, IT, LU, MC, NL, PT, SE), OAPI patent (BF, BJ, CF, CG, CI, CM, GA, GN, GW, ML, MR, NE, SN, TD, TG).</p> <p>Published <i>With international search report.</i></p>	

(54) Title: ANALYZING STRIP HAVING A FLUID CELL AND A METHOD OF ANALYZING A SAMPLE



(57) Abstract

A device according to the present invention has a fluid cell (13) with a driving fluid therein, and a breakable barrier (22) for selectively containing the driving fluid in the fluid cell. The device also includes a sample cell (25) having a collection chamber (28) capable of receiving a sample to be analyzed, capable of receiving the driving fluid from the first cell, and capable of allowing the sample to mix with the driving fluid to provide a mixed sample. In addition, the device has a filter (36) capable of capturing particulate matter contained within the sample, and a fluid collection reservoir (45). The device contains one or more types of antibodies capable of attaching to an analyte of interest. The invention also includes a method of using the device to detect an analyte.

FOR THE PURPOSES OF INFORMATION ONLY

Codes used to identify States party to the PCT on the front pages of pamphlets publishing international applications under the PCT.

AL	Albania	ES	Spain	LS	Lesotho	SI	Slovenia
AM	Armenia	FI	Finland	LT	Lithuania	SK	Slovakia
AT	Austria	FR	France	LU	Luxembourg	SN	Senegal
AU	Australia	GA	Gabon	LV	Latvia	SZ	Swaziland
AZ	Azerbaijan	GB	United Kingdom	MC	Monaco	TD	Chad
BA	Bosnia and Herzegovina	GE	Georgia	MD	Republic of Moldova	TG	Togo
BB	Barbados	GH	Ghana	MG	Madagascar	TJ	Tajikistan
BE	Belgium	GN	Guinea	MK	The former Yugoslav Republic of Macedonia	TM	Turkmenistan
BF	Burkina Faso	GR	Greece	ML	Mali	TR	Turkey
BG	Bulgaria	HU	Hungary	MN	Mongolia	TT	Trinidad and Tobago
BJ	Benin	IE	Ireland	MR	Mauritania	UA	Ukraine
BR	Brazil	IL	Israel	MW	Malawi	UG	Uganda
BY	Belarus	IS	Iceland	MX	Mexico	US	United States of America
CA	Canada	IT	Italy	NE	Niger	UZ	Uzbekistan
CF	Central African Republic	JP	Japan	NL	Netherlands	VN	Viet Nam
CG	Congo	KE	Kenya	NO	Norway	YU	Yugoslavia
CH	Switzerland	KG	Kyrgyzstan	NZ	New Zealand	ZW	Zimbabwe
CI	Côte d'Ivoire	KP	Democratic People's Republic of Korea	PL	Poland		
CM	Cameroon	KR	Republic of Korea	PT	Portugal		
CN	China	KZ	Kazakstan	RO	Romania		
CU	Cuba	LC	Saint Lucia	RU	Russian Federation		
CZ	Czech Republic	LI	Liechtenstein	SD	Sudan		
DE	Germany	LK	Sri Lanka	SE	Sweden		
DK	Denmark	LR	Liberia	SG	Singapore		
EE	Estonia						

5 ANALYZING STRIP HAVING A FLUID CELL
AND A METHOD OF ANALYZING A SAMPLE

CROSS CLAIM TO RELATED APPLICATION

This application claims the benefit of U.S.
10 Provisional Application No. 60/122,140, filed February
26, 1999, which is hereby incorporated by reference.

BACKGROUND OF THE INVENTION

1. Field Of The Invention

15 The present invention relates generally to devices
and methods for detecting and determining the amount of
an analyte in a biological sample. More specifically,
the invention relates to a device and a method for
determining blood levels of hormones including, but not
20 limited to, luteinizing hormone (LH), estradiol,
follicle-stimulating hormone (FSH), thyroid-stimulating
hormone (TSH), and/or progesterone. Additionally, the
invention relates to detection and determination of
endocrine dysfunctions in humans and other mammals.

25

2. Discussion of Related Art

Physiological changes in humans and other mammals
are often accompanied by changes in concentration of

-2-

various blood components. For example, ovulation in human and other mammalian females is preceded by a surge in the plasma concentration of LH in the blood. Commonly available tests used to detect this surge are

5 urine based. Urine tests have several drawbacks. They are awkward and often messy, and, more importantly, they are not as accurate as blood tests. In order for a detectable concentration of LH to be accumulated in the urine, the hormone must be released by the pituitary,

10 circulate in the blood, be sequestered in the kidneys, and finally excreted. The completion of these processes can take as long as 12 hours after the actual plasma surge for sufficient amount of LH to accumulate in the urine. Only after such time can LH be detected by these

15 tests. Since ovulation follows the LH surge by 12-18 hours, ovulation could take place by the time the user "predicts" ovulation using the urine test. Such a delay severely diminishes the fertile window, which usually lasts only a couple of days, and eliminates the

20 potential for urine tests to be used in a contraceptive manner.

In addition, such urine tests do not provide quantitative results. Instead, they indicate whether the concentration of LH is higher than normal or lower

25 than normal, a characteristic that prevents urine tests

from being used by women whose LH peak may not be as high as that of an average woman, for whom the urine tests are calibrated.

A more accurate method for LH surge detection is a
5 blood test. Theoretically, the LH level can be known nearly instantaneously, maximizing a female's reproductive window. Currently, however, the results of a clinical blood test are not available for 12-24 hours, and the high cost (typically - \$90) prevents wide spread
10 use.

Therefore, it is highly desirable to have a method and device for detecting LH, and other female reproductive hormones, in a more timely and cost effective manner.

15 LH is not the only analyte of interest. It is also desirable to detect basal plasma estradiol and FSH levels. Basal plasma estradiol and FSH levels are used by fertility clinics to determine the potential for *in vitro* fertilization (IVF) success. Basal estradiol
20 levels are taken on the third day of the menstrual cycle, when the concentration should be at its lowest. Studies show that where day-three estradiol was greater than 75 pg/mL, there were no successful IVF pregnancies. Furthermore, where estradiol was greater than 45 pg/mL
25 and FSH was greater than 17 IU/L, there were also no

successful IVF pregnancies. In addition, where both basal estradiol and FSH are low (less than 46 pg/Ml and 18 IU/L, respectively), then IVF can be successful 33.8% of the time. Also, it has been observed that basal FSH and estradiol levels obtained simultaneously on day-three of the menstrual cycle are essential tests for determining ovarian reserve in infertile patients. The term "ovarian reserve" reflects the future capacity of the ovaries to produce viable eggs. The primary reason that FSH levels would be elevated is that the follicles are not maturing in response to hormonal stimulation by the pituitary. As a result, the pituitary secretes more FSH. Failure to respond reflects an absence of viable ova in the ovaries, and carries with it a poor prognosis for future pregnancies.

Similarly, the cause for a particular patient's infertility can be diagnosed by monitoring various hormones. For example, elevated basal FSH indicates exhaustion of the ovaries, and offers a poor prognosis. In other cases, however, the cause for infertility is unrelated to the functioning of the reproductive system itself. For example, a disruption in TSH levels can cause an otherwise healthy reproductive system to become dysfunctional. In cases where the problem can be pinpointed to a secondary source, such as thyroid

dysfunction, treatment can be highly successful. A less expensive method to screen patients for thyroid function will allow physicians to screen more patients more frequently.

5 Another area where a cheaper and faster means of detecting and determining the levels of various hormones is in the detection of luteal phase defects, which affect 1-3% of infertile couples, and 1/3 of women with spontaneous abortion. The luteal phase is the time in a
10 normal menstrual cycle after the ovum has ruptured, but preceding menses. Insufficient production of estradiol, progesterone, and/or LH during this time will prevent the endometrium and/or ovum from developing adequately, making implantation impossible. If a physician
15 determines the ovaries respond well enough (i.e. there are viable eggs left), then other endocrine problems, such as luteal phase defects, can be controlled via appropriate medications. A more cost-effective means of screening patients for endocrine problems will,
20 therefore, allow more pregnancies to be saved.

 In any of the above hormone assays, high costs and problematic methodology requires an infertile or amenorrheic woman to undergo many batteries of hormone tests, often with samples taken on several successive
25 days. Therefore, a need exists to provide an effective

and inexpensive device and method to allow a user to obtain prompt and reliable information of a particular hormonal state of the user.

5 SUMMARY OF THE INVENTION

Accordingly, it is an object of the present invention to provide a device and method for providing analysis of the levels of hormones in blood including, but not limited to, LH, estradiol, FSH, TSH, and/or
10 progesterone, to predict certain physiological changes. Examples of such physiological changes include, but are not limited to, determination of ovarian state and proper function of the reproductive system, as well as detection of endocrine causality of infertility in human
15 and other mammalian females.

It is a further object of the present invention to provide a device and method for rapid detection of analytes in a biological sample. In particular, the device of the present invention serves to determine the
20 blood level of various hormones, such as, for example, estradiol, FSH, TSH, and/or progesterone, of a patient, and for providing the results to a user. The device of the present invention may be operated with very little skill, and requires a minimum number of actions by the
25 user to obtain a dependable analytical result.

A device according to the present invention has a fluid cell with a driving fluid therein, and a breakable barrier for selectively containing the driving fluid in the fluid cell. The device also includes a sample cell
5 having a collection chamber capable of receiving a sample to be analyzed, capable of receiving the driving fluid from the first cell, and capable of allowing the sample to mix with the driving fluid to provide a mixed sample. In addition, the device has a filter capable of
10 capturing particulate matter contained in the sample, and a fluid collection reservoir. The device contains one or more types of antibodies capable of attaching to an analyte of interest.

A method according to the present invention begins
15 by providing a device, such as that described above, and providing a sample to the collection cell. Next, the barrier is broken to provide the driving fluid to the collection cell, where the sample and the driving fluid are mixed. Then a first type of antibody is introduced
20 to the sample. The first type of antibody has an affinity for the analyte of interest to form a tagged analyte. The method also includes filtering to remove particulate matter in the sample, and detecting the tagged analyte in the detection cell. The method may

also collect the driving fluid in the collection reservoir.

Other objects and advantages of the present invention will become apparent to those skilled in the art from the following detailed description read in conjunction with the attached drawings and claims appended hereto.

BRIEF DESCRIPTION OF THE DRAWINGS

For a fuller understanding of the nature and objects of the present invention, reference should be made to the following detailed description taken in conjunction with the accompanying drawings, in which:

Figure 1A is a perspective view of a device according to the present invention;

Figure 1B is a cross-sectional view of the device shown in Figure 1;

Figures 2 and 3 are perspective views of devices according to the present invention; and

Figures 4A and 4B show steps of a method according to the present invention.

BEST MODE FOR CARRYING OUT THE INVENTION

Figures 1A and 1B show a device 10 according to the present invention. The device 10 includes a fluid cell

13 having driving fluid 16 therein and a breakable barrier 19 for selectively containing the driving fluid 16 in the fluid cell 13. The driving fluid 16 may include water, a buffer and blocking agents. Suitable buffers include phosphate, tris, glycine and the like, generally in the molarity of 0.1 to 3.0. Suitable blocking agents include bovine serum albumin, diluted serum, non-fat dry milk, and casein. Other additives in the driving fluid may include heparin or an anti-microbial substance.

The breakable barrier 19 may be made from Mylar with a metalized coating including aluminum. Alternatively, the breakable barrier 19 may be made from a polymer with a fluorine treated gas barrier. The breakable barrier 19 is preferably located at a first edge 22 of the fluid cell 13 and may be broken by increasing the pressure in the fluid cell 13, for example by squeezing the fluid cell 13 between a thumb and index finger. When the breakable barrier 19 is broken, the driving fluid 16 flows into another cell, such as the sample cell 25.

The sample cell 25 has a collection chamber 28 capable of receiving a sample to be analyzed. For example, the sample cell 25 may have an orifice 31 through which the sample, such as a drop of blood, may

-10-

be deposited. The sample cell 25 is capable of receiving the driving fluid 16 upon breaking the breakable barrier 19, and is capable of allowing the sample to mix with the driving fluid 16 to provide a
5 mixed sample.

The device shown in Figures 1A and 1B also has a filter 33 capable of capturing particulate matter from the mixed sample. The filter 33 may include glass fibers and may be contained in a filter cell 36. As the
10 mixed sample moves through the filter 33, particulate matter in the mixed sample is captured in the filter 33 to provide a filtered mixed sample to another cell, such as the first antibody cell 39.

The first antibody cell 39 has a first type of
15 antibody capable of attaching to an analyte of interest in the filtered mixed sample. If the analyte of interest is in the filtered mixed sample, the first type of antibody combines with the analyte to form a tagged analyte in the filtered mixed sample.

20 The first type of antibody may be provided in the first antibody cell 39 via a porous nonreactive carrier matrix. Such matrices are commonly used for nucleic acid and protein binding. The matrix may include nitrocellulose or nylon. When the carrier matrix is
25 nitrocellulose, the first type of antibody can be

-11-

directly immobilized on the carrier matrix without the need of a chemical treatment. However, for other matrices, immobilization can be accomplished by well known techniques, such as treatment with cyanogen
5 bromide or carbonyldiimidazole.

The first antibody may include a monoclonal antibody, a polyclonal antibody, or fragments thereof. The particular choice for the first type of antibody will depend upon the analyte to be detected. For
10 example for the detection of LH, specific antibodies to LH can be immobilized on the carrier matrix.

Furthermore, the first type of antibody may include a chromophore, fluorophore in order to make detection easier. Once the filtered mixed sample flows through
15 the first antibody cell 39, the filtered mixed sample flows into another cell, such as the detecting cell 42.

The detecting cell 42 may have a second type of antibody capable of attaching to the tagged analyte, if present in the filtered mixed sample, to provide a
20 secondary tag on the tagged analyte (the "secondarily tagged analyte"). Alternatively, or in addition, the second type of antibody may be capable of attaching to a second analyte of interest. In that situation, the second type of antibody attaches to the second analyte
25 to provide a labeled analyte. The second type of

-12-

antibody is preferably immobilized within the detecting cell to capture and retain the analyte of interest. The second type of antibody may be a monoclonal antibody, a polyclonal antibody, and/or fragments thereof. The
5 second type of antibody preferably includes a detectable molecule or complex, such as a chromophore and fluorescent molecules and complexes.

The detecting cell 42 provides the tagged analyte, the secondarily tagged analyte, and/or the labeled
10 analyte, as the case may be, for detection and analysis. The detecting cell 42 preferably allows the filtered mixed sample to flow out of the detecting cell 42. The device may include a collection cell 45 having a fluid collection reservoir 48 for receiving fluid from the
15 detecting cell 42. The collection reservoir 48 may be an empty chamber, or alternatively, may have an absorbent material 49 therein for capturing fluid. In addition, the detecting cell 42 preferably includes one or more translucent sides 50 for permitting the tagged
20 analyte, the secondarily tagged analyte and/or the labeled analyte to be detected, as further described below.

Figure 2 depicts an alternative embodiment of the present invention, in which the filter cell 36 is placed
25 between the fluid cell 13 and the sample cell 25.

Figure 3 depicts another embodiment of the present invention in which the first antibody cell 39 has been eliminated. Instead of providing a separate cell for housing the first type of antibody, the first type of antibody is included in the driving fluid 16. Alternatively, the first type of antibody may be included in the filter 33.

Fluorescent labeled antibodies having an affinity for specific analytes are available commercially or can be prepared by using techniques known in the art. For example, kits for fluorescent tagging and labeling of antibodies are available commercially as molecular probes or from Pierce.

It may be preferable to store the first type and/or the second type of antibody in a light protected compartment until the device is ready to be used. To prevent light from inhibiting the effectiveness of the device 10, the device 10 is preferably wrapped in a light impermeable substance, such as a metallic foil.

Figures 4A and 4B show steps of a method according to the present invention. The method begins by providing a device (step 100) similar to that described above. Next, a sample, such as human blood, is provided (step 103) to the collection cell. The barrier is broken to release the driving fluid (step 106) in the

fluid cell. The barrier may be broken by increasing the pressure inside the fluid cell, for example by squeezing the fluid cell between the index finger and thumb of a person.

5 The sample is mixed (step 109) with the driving fluid to provide a mixed sample, and a first type of antibody is provided (step 112) to the sample. If the analyte of interest is present in the sample, the first type of antibody will tag the analyte. The filter is
10 used (step 115) to remove particulate matter introduced by the sample, and the device is analyzed (step 118) for the presence of tagged analytes.

 One or more additional steps may be added to the method. For example, a second type of antibody may be
15 provided (step 121) to the mixed sample. The second type of antibody may or may not have an affinity for the same analyte of interest as the first type of antibody. The method may also include collecting (step 124) driving fluid in the collection reservoir.

20 It will be recognized that the intensity of the color, fluorescence, or luminescence of the tagged analyte, the secondarily tagged analyte and/or the labeled analyte, as the case may be, is indicative of the amount of the chromophore, fluorophore, luminescent
25 or other label. Therefore measuring such intensity is

indicative of the amount of the analyte(s) of interest
in the sample. The color intensity may be measured by
comparison to a color chart. In addition, the color
intensity may be measured by focusing a light 51 on the
5 detecting cell 42, and receiving transmitted light with
a detector 54, or by using the apparatuses described in
U.S. Patent application serial number 09/208,648, which
is hereby incorporated by reference.

Although the present invention has been described
10 with respect to one or more particular embodiments, it
will be understood that other embodiments of the present
invention may be made without departing from the spirit
and scope of the present invention. Hence, the present
invention is deemed limited only by the appended claims
15 and the reasonable interpretation thereof.

What is claimed is:

1. An analyzing device, comprising:
 - a first cell having driving fluid therein and a
5 breakable barrier for selectively containing the driving
fluid in the first cell;
a second cell having a collection chamber capable
of receiving a sample to be analyzed, capable of
receiving the driving fluid when the barrier is broken,
10 and capable of allowing the sample to mix with the
driving fluid to provide a mixed sample;
a filter capable of capturing particulate matter
contained in the sample;
a fourth cell having a first type of antibody
15 capable of attaching to an analyte of interest in the
mixed sample to form a tagged analyte;
a fluid collection reservoir for receiving fluid
from the sample cell.
- 20 2. The device of claim 1, further comprising a fifth
cell having a second type of antibody capable of
attaching to the tagged analyte.

3. The analyzing device of claim 1, wherein the driving fluid is a buffered solution.
4. The analyzing device of claim 2, wherein the second type of antibody is a mono-clonal antibody.
5. The analyzing device of claim 2, wherein the second type of antibody is a poly-clonal antibody.
- 10 6. The analyzing device of claim 2, wherein the fifth cell has a translucent side.
7. The analyzing device of claim 1, wherein the driving fluid includes a blocking agent.
- 15 8. The analyzing device of claim 1, wherein the driving fluid includes a second type of antibody capable of attaching to the analyte of interest.
- 20 9. The analyzing device of claim 1, wherein the filter includes glass fibers.
10. The analyzing device of claim 1, wherein the first type of antibody is a mono-clonal antibody.

11. The analyzing device of claim 1, wherein the first type of antibody is a poly-clonal antibody.

12. The analyzing device of claim 1, wherein the first
5 type of antibody is tagged with a chromophore.

13. The analyzing device of claim 1, wherein the first type of antibody is tagged with a fluorophore.

10

14. An analyzing device, comprising:

a fluid cell having driving fluid therein and a breakable barrier for selectively containing the driving fluid in the fluid cell, wherein the fluid contains a
15 first type of antibody capable of attaching to an analyte to form a tagged analyte;

a sample cell having a collection chamber capable of receiving a sample to be analyzed, capable of receiving the driving fluid from the fluid cell, and
20 capable of allowing the sample to mix with the driving fluid to provide a mixed sample;

a filter capable of capturing particulate matter contained in the sample; and

a fluid collection reservoir for receiving the
25 fluid from the sample cell.

15. The analyzing device of claim 14, further comprising a cell having a second type of antibody therein capable of attaching to the tagged analyte.

5

16. The analyzing device of claim 15, wherein the cell having the second antibody therein has a translucent side.

10 17. The analyzing device of claim 14, further comprising a detection cell having a translucent side.

18. An analyzing device, comprising:

15 a fluid cell having driving fluid therein and a breakable barrier for selectively containing the driving fluid in the fluid cell;

20 a first antibody cell having a first type of antibody capable of attaching to an analyte of interest to form a tagged analyte, and which is capable of being carried by the driving fluid to provide a modified driving fluid;

a sample cell having a collection chamber capable of receiving a sample to be analyzed, capable of receiving the modified driving fluid, and capable of

allowing the sample to mix with the modified driving fluid to produce a mixed sample;

a filter capable of capturing particulate matter contained in the sample;

5 a second antibody cell having a second type of antibody capable of attaching to the tagged analyte; and

a collection cell having a fluid collection reservoir for receiving fluid from the second antibody cell.

10

19. The analyzing device of claim 18, wherein the second antibody cell has a translucent side.

20. A method of detecting an analyte of interest in a sample, comprising:

15 providing a device having (A) a fluid cell including a driving fluid therein and a breakable barrier for selectively containing the driving fluid in the fluid cell, and (B) a collection cell including a collection chamber capable of receiving a sample to be
20 analyzed, capable of receiving the driving fluid from the fluid cell, and capable of allowing the sample to mix with the driving fluid to provide a mixed sample, and (C) a filter capable of capturing particulate matter
25 contained in the sample, and (D) a first type of

-21-

antibody capable of attaching to an analyte of interest in the sample to form a tagged analyte, (E) a detection cell, and (F) a fluid collection reservoir for receiving fluid from the detection cell;

5 providing the sample to the collection cell;

breaking the barrier to provide the driving fluid to the collection cell;

mixing the sample with the driving fluid to provide a mixed sample;

10 providing the first type of antibody to the sample, the first type of antibody having an affinity for the analyte of interest to form the tagged analyte;

filtering the sample in the filter;

detecting the tagged analyte in the detection cell;

15 collecting driving fluid in the collection reservoir.

21. The method of claim 20, wherein the barrier is broken by increasing a pressure within the fluid cell.

20

22. The method of claim 21, wherein the pressure within the fluid cell is increased by squeezing the fluid cell.

23. The method of claim 20, wherein the sample is
25 blood.

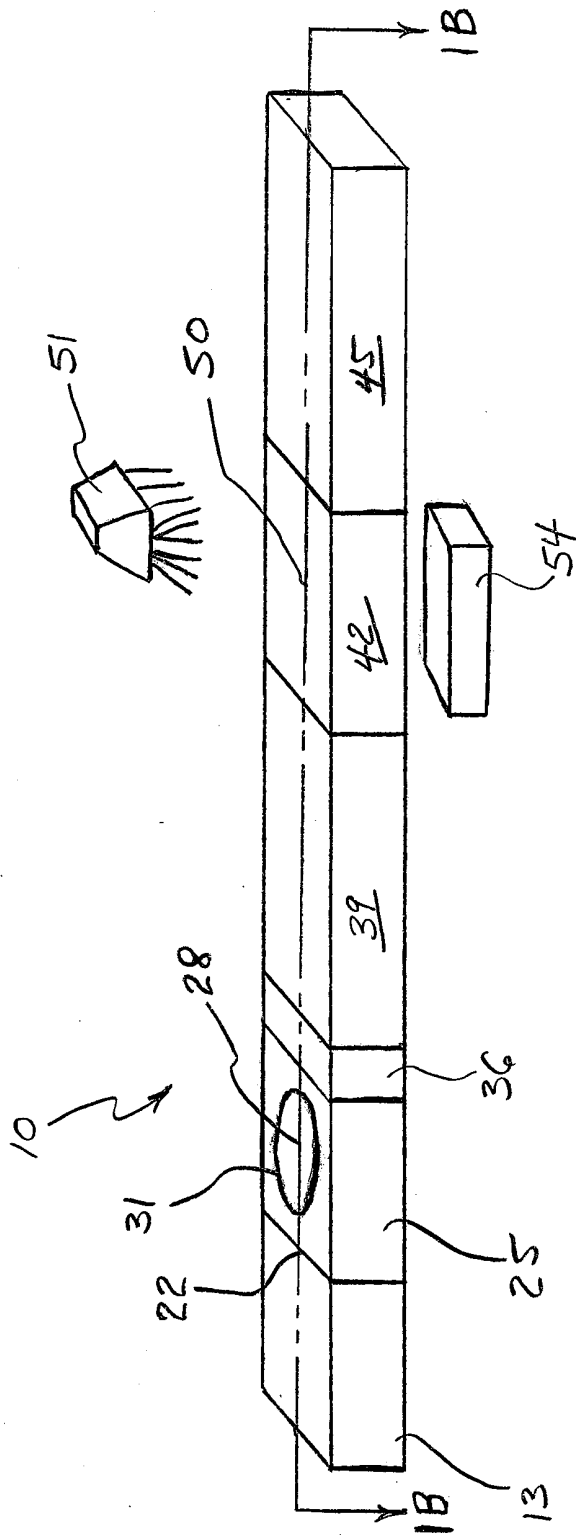

FIG. 1A

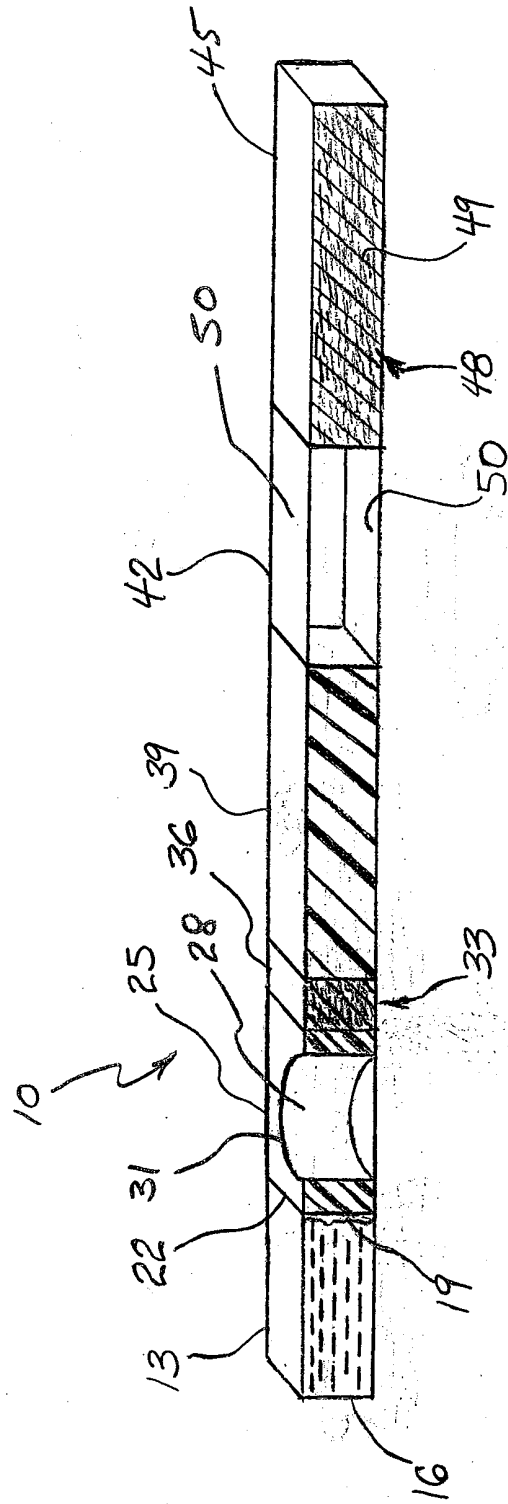

FIG. 1B

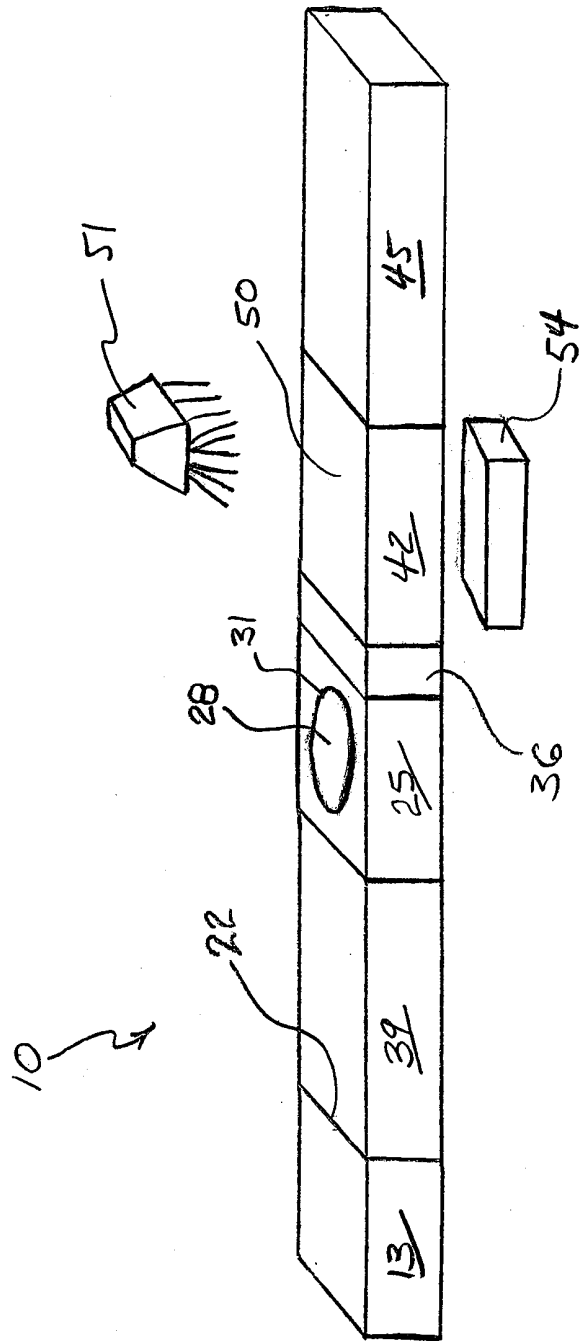

FIG. 2

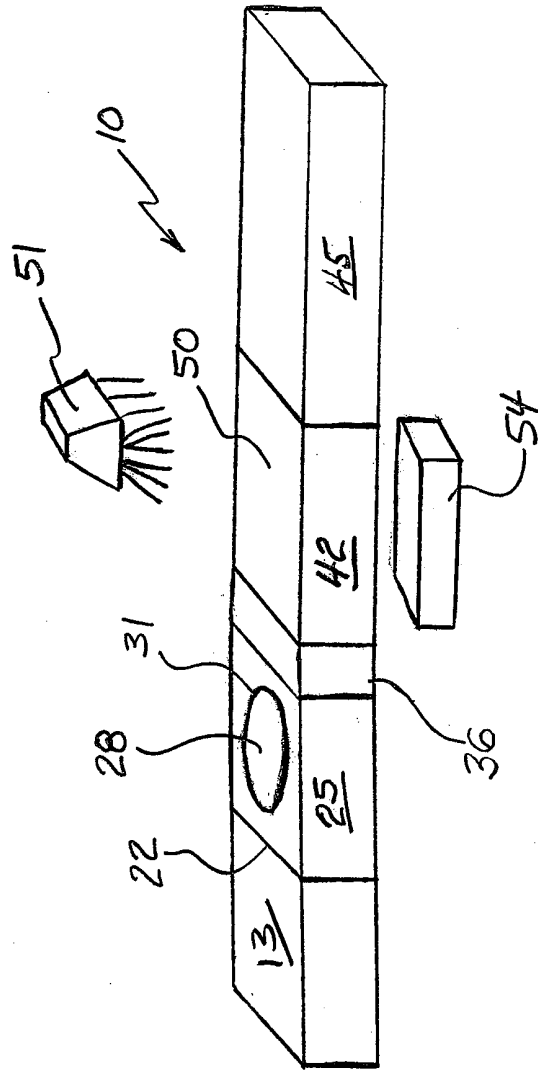

FIG. 3

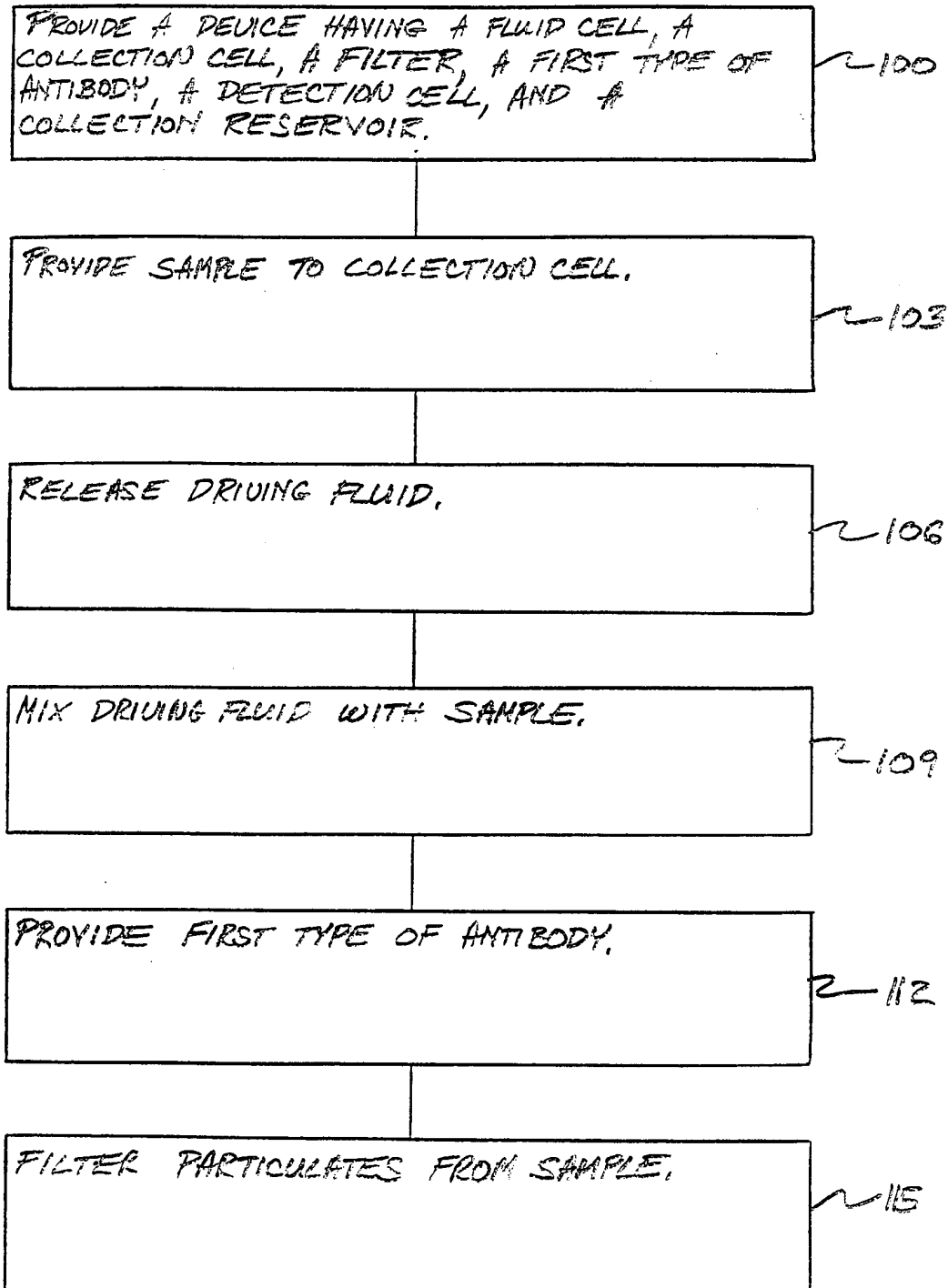

FIG. 4A

To FIG. 4B

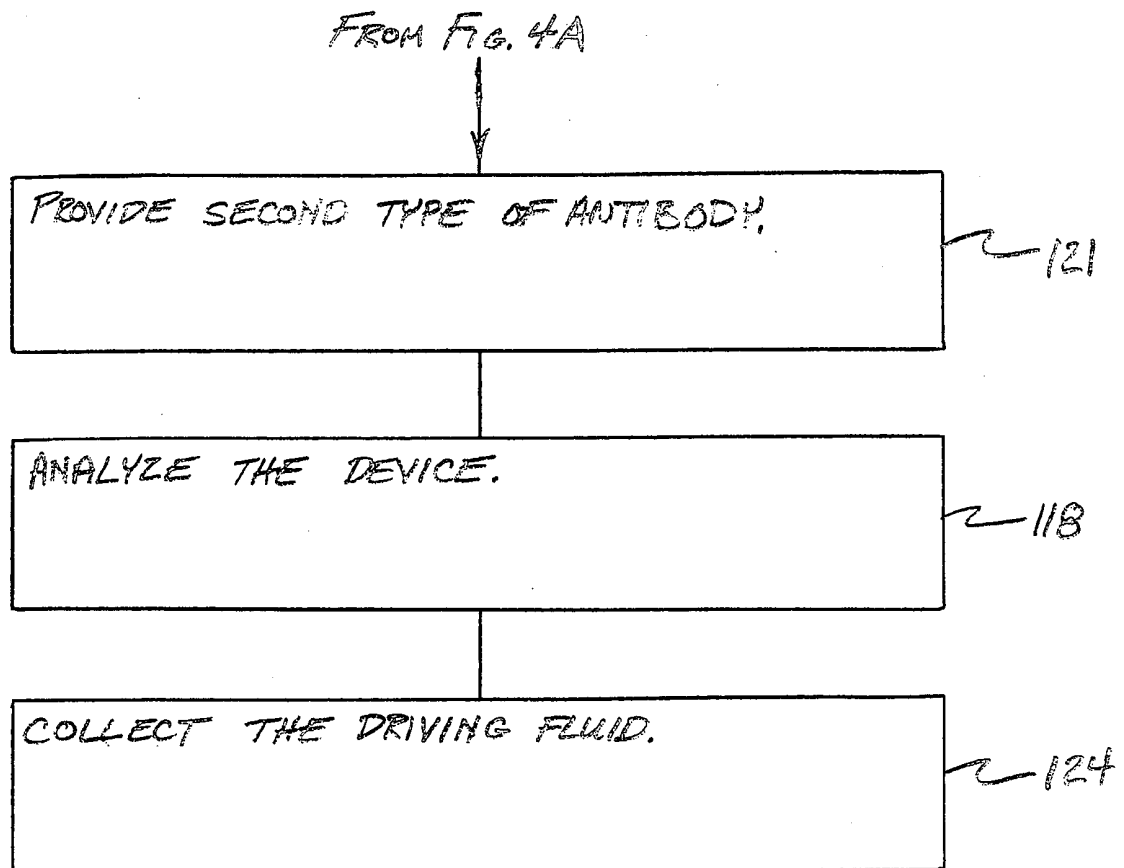

FIG 4B

INTERNATIONAL SEARCH REPORT

International application No.
PCT/US00/05038**A. CLASSIFICATION OF SUBJECT MATTER**

IPC(7) : G01N 31/22, 21/29, 21/41, 15/06, 33/48

US CL : 422/57, 60, 68.1, 82.05, 82.08

According to International Patent Classification (IPC) or to both national classification and IPC

B. FIELDS SEARCHED

Minimum documentation searched (classification system followed by classification symbols)

U.S. : 422/57, 60, 68.1, 82.05, 82.08

Documentation searched other than minimum documentation to the extent that such documents are included in the fields searched

Electronic data base consulted during the international search (name of data base and, where practicable, search terms used)

WEST 2.0

C. DOCUMENTS CONSIDERED TO BE RELEVANT

Category*	Citation of document, with indication, where appropriate, of the relevant passages	Relevant to claim No.
Y, P	US 5,989,921 A (CHARLTON et al) 23 November 1999, Figures 1 and 2, col. 1, line 61- col. 3, line 55.	1, 4-6, 10, 11, 14-20, 23
Y	US 5,874,216 A (MAPES) 23 February 1999, Figure 1, col. 6, line 63 - col. 8, line 11.	1, 2, 9, 14-16, 18, 20, 23
Y	US 5,821,073 A (LEE) 3 October 1998, col. 3 line 61 - col. 4, line 64.	1, 3, 14, 18, 20
Y	US 5,391,478 A (GREENE et al) 21 February 1995, col. 3, lines 31-50.	1, 4, 10, 14, 18, 20, 23
Y	US 5,356,782 A (MOORMAN et al) 18 October 1994, Figures 1 and 2, col. 8, lines 31-43, col. 10, lines 36-50.	1, 4, 5, 14, 18, 20, 23

 Further documents are listed in the continuation of Box C. See patent family annex.

* Special categories of cited documents:	*T* later document published after the international filing date or priority date and not in conflict with the application but cited to understand the principle or theory underlying the invention
A document defining the general state of the art which is not considered to be of particular relevance	*X* document of particular relevance; the claimed invention cannot be considered novel or cannot be considered to involve an inventive step when the document is taken alone
B earlier document published on or after the international filing date	*Y* document of particular relevance; the claimed invention cannot be considered to involve an inventive step when the document is combined with one or more other such documents, such combination being obvious to a person skilled in the art
L document which may throw doubts on priority claim(s) or which is cited to establish the publication date of another citation or other special reason (as specified)	*&* document member of the same patent family
O document referring to an oral disclosure, use, exhibition or other means	
P document published prior to the international filing date but later than the priority date claimed	

Date of the actual completion of the international search

21 MAY 2000

Date of mailing of the international search report

13 JUN 2000

Name and mailing address of the ISA/US
Commissioner of Patents and Trademarks
Box PCT
Washington, D.C. 20231

Facsimile No. (703) 305-3230

Authorized officer

LATOYA CROSS

Telephone No. (703) 308-0661

INTERNATIONAL SEARCH REPORT

International application No.
PCT/US00/05038

C (Continuation). DOCUMENTS CONSIDERED TO BE RELEVANT

Category*	Citation of document, with indication, where appropriate, of the relevant passages	Relevant to claim No.
Y	US 5,206,177 A (DELACROIX et al) 27 April 1993, Figures 1 and 2, col. 6, line 12 - col. 8, line 15.	1, 14, 18, 20, 23
Y	US 5,200,317 A (GEORGEVICH) 06 April 1993, col. 3, lines 11-61.	1, 14, 18, 20, 23
Y	US 5,116,576 A (STANLEY) 26 May 1992, see abstract and figure 1d.	1, 14, 18, 20, 23
Y	US 4,806,312 A (GREENQUIST) 21 February 1989, col. 4, lines 10 - col. 5, line 6.	1, 14, 18, 20
A	US 5,591,645 A (ROSENSTEIN) 07 January 1997, see entire document.	
A	US 5,552,276 A (MOCHIDA et al) 03 September 1996, see entire document.	
A	US 5,763,262 A (WONG et al) 09 June 1998, see entire document.	