

(19) (KR)  
(12) (B1)

(51) 。 Int. Cl. <sup>6</sup> (45) 2001 10 24  
H02P 5/402 (11) 10 - 0296393  
(24) 2001 05 09

(21) 10 - 1997 - 0013337 (65) 1998 - 0076577  
(22) 1997 04 07 (43) 1998 11 16

(73) 2 120 - 1 105 - 803

(72) 2 120 - 1 105 - 803

(74)

:

(54)

(feedback)

, 가 ,

(4) 가 (7,8) 가 (1) (6) (3) , (1) (6) (5) (1)

1 .

2 .

3 .

4 .

\*

1 : 2 :

3 : 4 :

5 : 6 :

7,8 : 9,10 :

12 : 13 :

(controller)가

가

가

가

가

가

,  
 ,  
 (5) (7,8)가 (6)  
 ,  
 (7,8) (4) ,  
 (5) (6) (3) ,  
 (3) (13) , (12) ,  
 (12) (3)가 .  
 ,  
 1 (3) (1) (5) , 2 (sealing)  
 (3) (1)  
 (4) (3) (1) (4) (1)  
 (1) (5) , 가 (6) (6) ,  
 (5) , (6) (5) ( ) (6) .  
 , (3) (12) (13) (3) ,  
 (ON) (STOP) ( ) ( ) .  
 4 (12) , 가 (1) , (3)  
 11 , 12a .  
 , (1)가 (1) (5) , (6) (6)  
 (3) (4) (1) , 가 (3)  
 (4) (1) (1) (3)  
 (3) (1)  
 가 , (12) (on) , (stop) ,  
 (3) 가 가 .  
 (2) (3), (4) (1)

, 1 ,

가 가 , 가 가

가 가 .

(57)

1.

,

(5) (7,8)가 (6)

,

(7,8)

(5) (6)

(4)

, (3) ,

(3) (13) , (12)

,

(12) (3)가

.

1

**[ 5 1 ]**

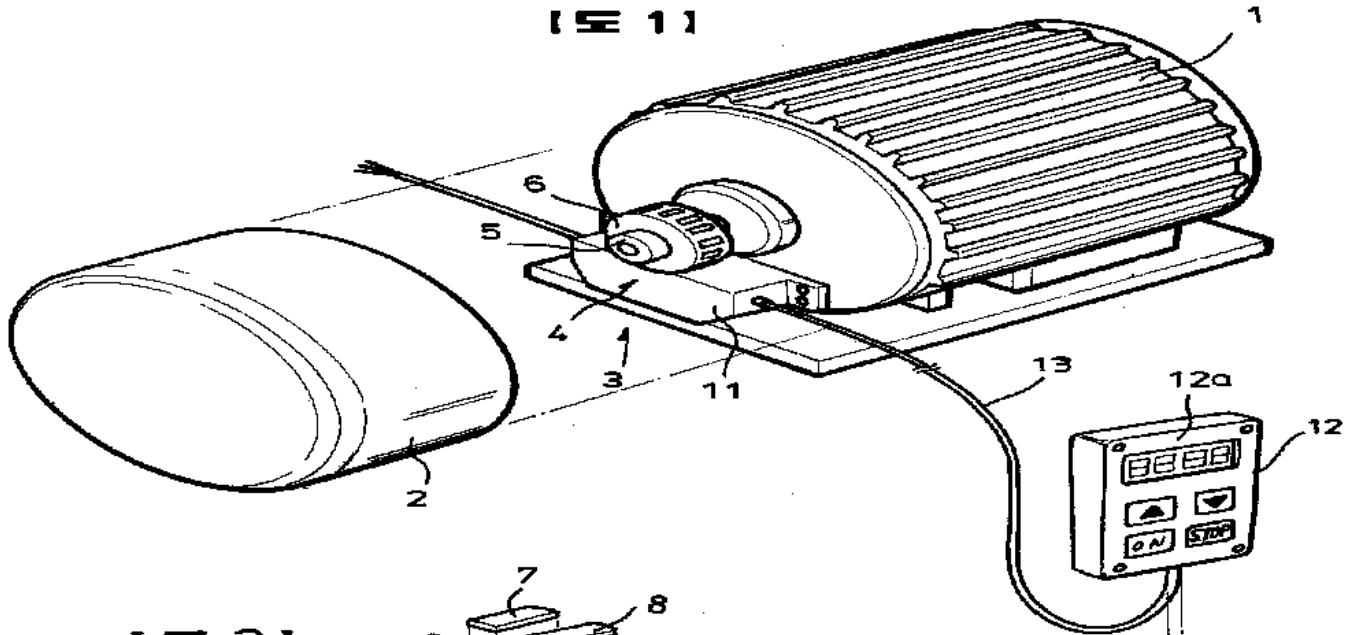

**[ 5 2 ]**

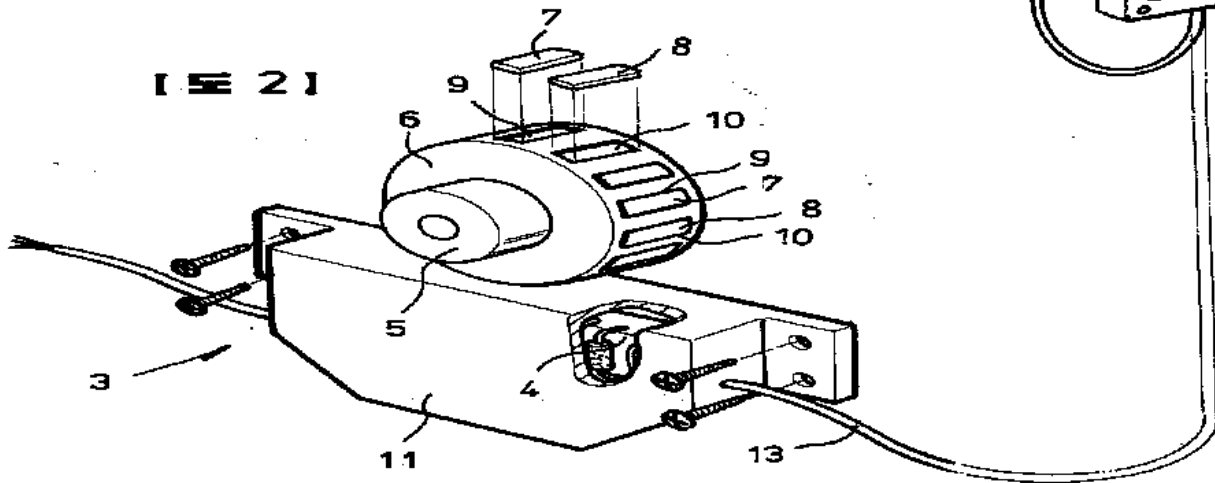

2

**[ 5 1 ]**

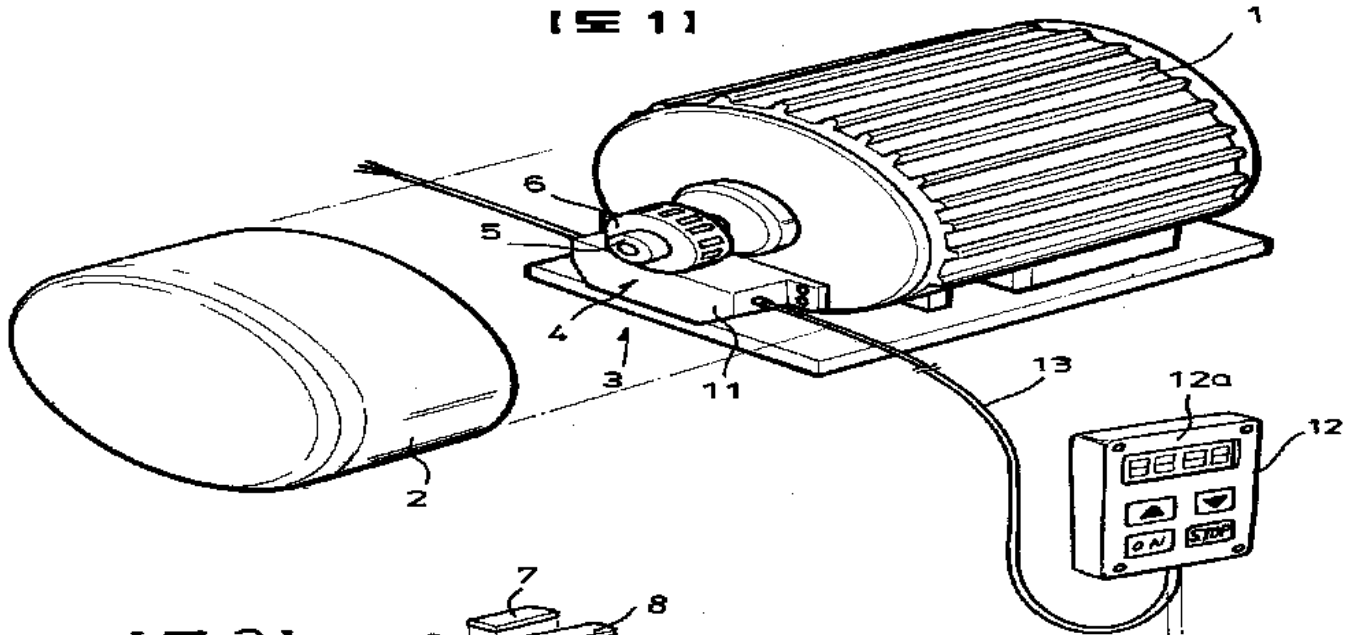

**[ 5 2 ]**

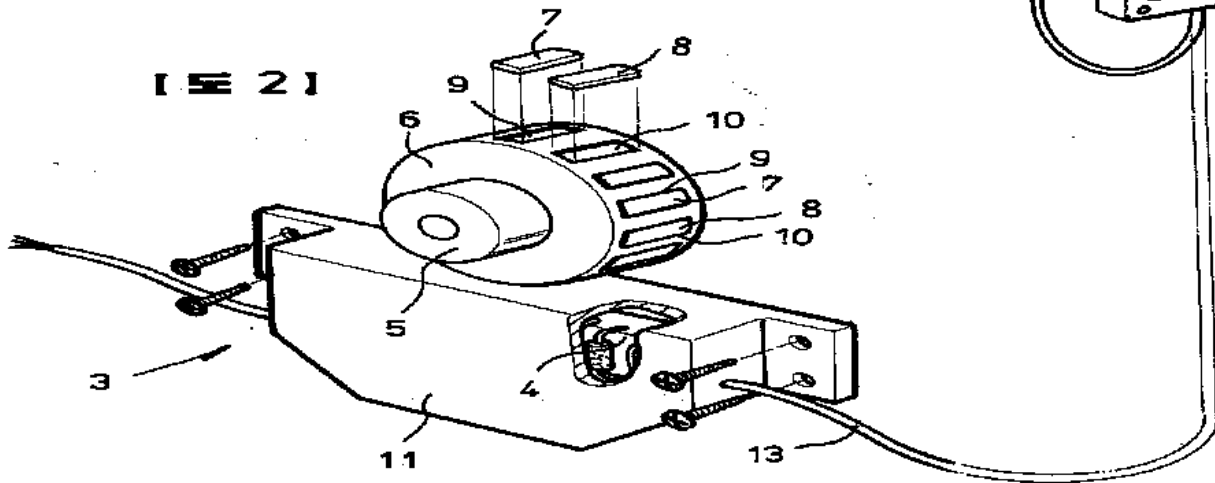

3

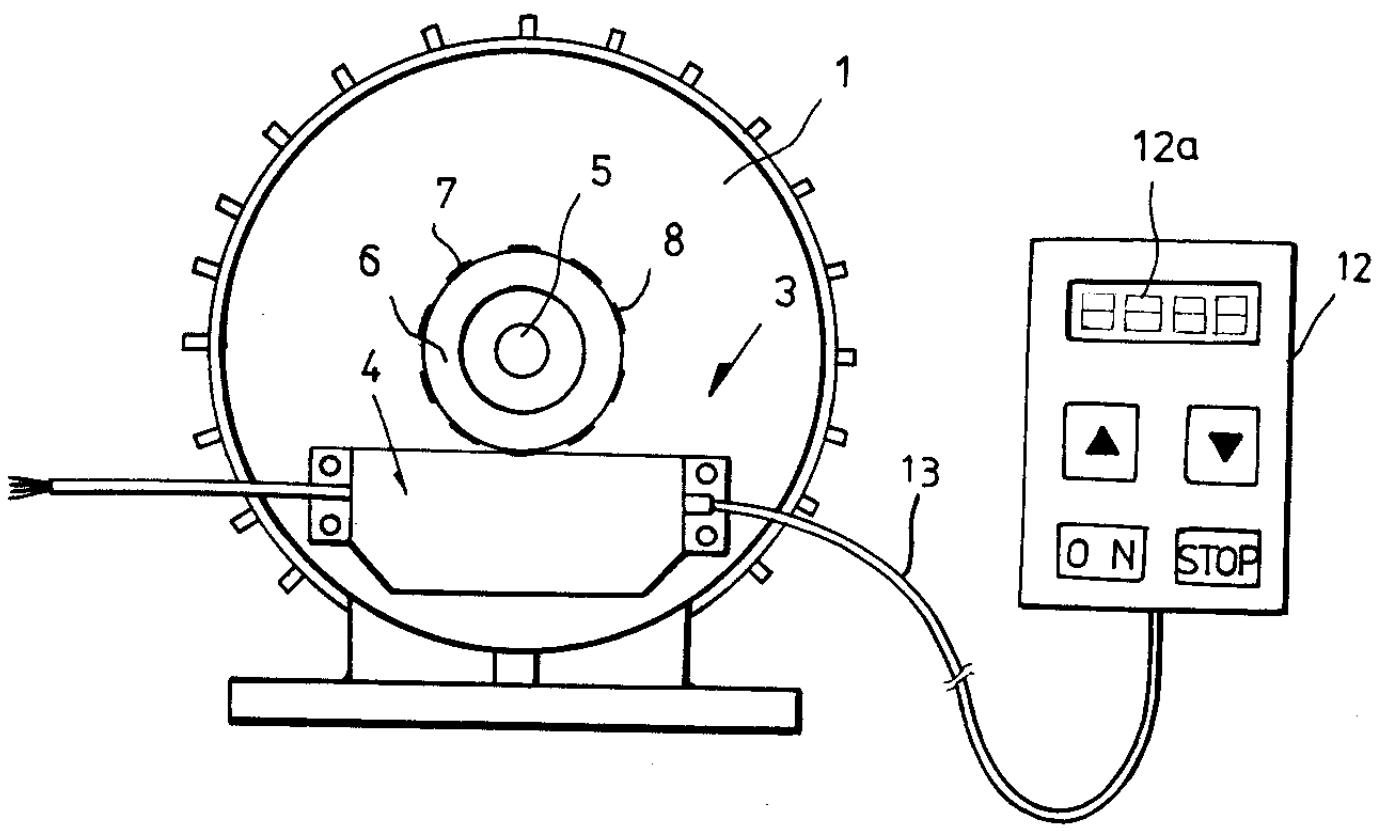

4

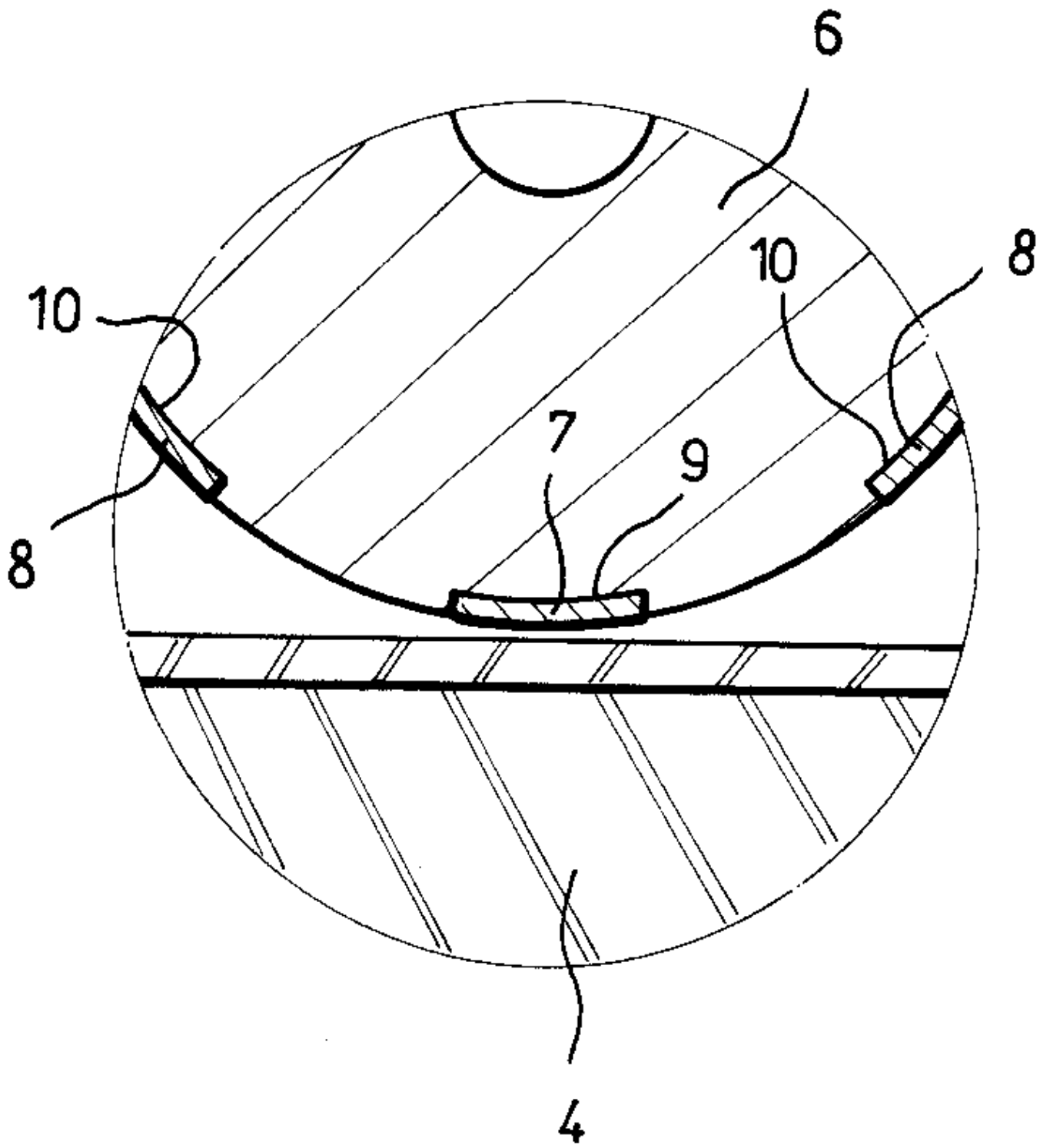



5

