



- (51) **International Patent Classification:**
B65B 9/20 (2012.01) *B65B 55/02* (2006.01)
- (21) **International Application Number:**
PCT/EP2020/055568
- (22) **International Filing Date:**
03 March 2020 (03.03.2020)
- (25) **Filing Language:** English
- (26) **Publication Language:** English
- (30) **Priority Data:**
19162708.2 14 March 2019 (14.03.2019) EP
- (71) **Applicant: TETRA LAVAL HOLDINGS & FINANCE S.A.** [CH/CH]; 70, Avenue Général-Guisan, CH-1009 Pully (CH).
- (72) **Inventors: FERRARINI, Filippo;** Via Geminiano Rondelli, 7, 41126 Modena (IT). **CARRERI, Marco;** Via Lodovico Vedriani, 50, 41124 Modena (IT). **BOCCOLARI, Stefano;** Via Francesco Panini, 51, 41123 Modena (IT). **RONCAGLIA, Claudio;** Via Belfiore, 4/1, 41030 San Prospero (IT). **FERRARI, Claudio;** Via Vittorio Emanuele, 55, 42020 Albinca (IT).
- (74) **Agent: TETRA PAK - PATENT ATTORNEYS SE;** AB Tetra Pak, Patent Department Ruben Rausing's gata, 22186 Lund (SE).
- (81) **Designated States** (*unless otherwise indicated, for every kind of national protection available*): AE, AG, AL, AM, AO, AT, AU, AZ, BA, BB, BG, BH, BN, BR, BW, BY, BZ, CA, CH, CL, CN, CO, CR, CU, CZ, DE, DJ, DK, DM, DO, DZ, EC, EE, EG, ES, FI, GB, GD, GE, GH, GM, GT, HN, HR, HU, ID, IL, IN, IR, IS, JO, JP, KE, KG, KH, KN, KP, KR, KW, KZ, LA, LC, LK, LR, LS, LU, LY, MA, MD, ME, MG, MK, MN, MW, MX, MY, MZ, NA, NG, NI, NO, NZ, OM, PA, PE, PG, PH, PL, PT, QA, RO, RS, RU, RW, SA, SC, SD, SE, SG, SK, SL, ST, SV, SY, TH, TJ, TM, TN, TR, TT, TZ, UA, UG, US, UZ, VC, VN, WS, ZA, ZM, ZW.
- (84) **Designated States** (*unless otherwise indicated, for every kind of regional protection available*): ARIPO (BW, GH, GM, KE, LR, LS, MW, MZ, NA, RW, SD, SL, ST, SZ, TZ, UG, ZM, ZW), Eurasian (AM, AZ, BY, KG, KZ, RU, TJ, TM), European (AL, AT, BE, BG, CH, CY, CZ, DE, DK, EE, ES, FI, FR, GB, GR, HR, HU, IE, IS, IT, LT, LU, LV, MC, MK, MT, NL, NO, PL, PT, RO, RS, SE, SI, SK, SM, TR), OAPI (BF, BJ, CF, CG, CI, CM, GA, GN, GQ, GW, KM, ML, MR, NE, SN, TD, TG).

(54) **Title:** PACKAGING MACHINE FOR PRODUCING SEALED PACKAGES

(57) **Abstract:** There is described a packaging machine (1) for producing sealed packages (2) of a pourable product comprising at least an isolation housing (18), a formation apparatus (19) at least partially arranged within the isolation housing (18) and being configured to form and/or obtain sealed semi-finalized packs (9) of the pourable product, an outlet conveying unit (20) configured to receive the sealed semi-finalized packs (9) within the isolation housing (18) and to advance the sealed semi-finalized packs (9) out of the isolation housing (18) and to a transfer station (21) and a final folding unit (22) arranged at the transfer station (21) and configured to receive the sealed semi-finalized packs (9) from the outlet conveying unit (20) and to treat and/or manipulate the sealed semi-finalized packs (9) such to obtain the packages (2).

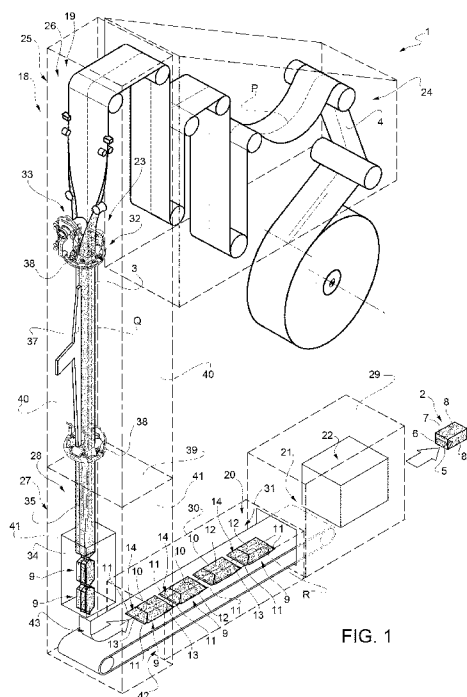

FIG. 1

Published:

— *with international search report (Art. 21(3))*

PACKAGING MACHINE FOR PRODUCING SEALED PACKAGESTECHNICAL FIELD

The present invention relates to a packaging machine for producing sealed packages of a pourable product, in particular a pourable food product.

BACKGROUND ART

As is known, many liquid or pourable food products, such as fruit juice, UHT (ultra-high-temperature treated) milk, wine, tomato sauce, etc., are sold in packages made of sterilized packaging material.

A typical example is the parallelepiped-shaped package for liquid or pourable food products known as Tetra Brik Aseptic (registered trademark), which is made by sealing and folding laminated strip packaging material. The packaging material has a multilayer structure comprising a base layer, e.g. of paper, covered on both sides with layers of heat-seal plastic material, e.g. polyethylene. In the case of aseptic packages for long-storage products, such as UHT milk, the packaging material also comprises a layer of oxygen-barrier material (an oxygen-barrier layer), e.g. an aluminum foil, which is superimposed on a layer of heat-seal plastic material, and is in turn covered with another layer of heat-seal plastic material forming the inner face of the package eventually contacting the food product.

Packages of this sort are normally produced on fully automatic packaging machines.

There are known packaging machines, which advance a web of packaging material through a sterilization apparatus for sterilizing the web of packaging material at a sterilization station and into an isolation chamber in which the sterilized web of packaging material is maintained and advanced. During advancement of the web of

packaging material within the isolation chamber, the web of packaging material is folded and sealed longitudinally at a tube forming station to form a tube having a longitudinal seam portion, the tube being further fed
5 along an advancing (vertical) direction.

In order to complete the forming operations, the tube is filled with a pourable product, in particular a pourable food product, and is transversally sealed and subsequently cut along equally spaced transversal cross
10 sections within a package forming unit of the packaging machine during advancement along the advancing direction.

Pillow packages are so obtained within the packaging machine, each pillow package having a longitudinal sealing band, a top transversal sealing band and a bottom
15 transversal sealing band.

These pillow packages define sealed semi-finalized packs having a central main portion and a plurality of flaps protruding from the central main portion. In order to obtain the finalized packages, the pillow packages are
20 further formed, and the flaps are folded and sealed onto the central main portion.

A typical packaging machine of this type comprises:

- a conveying device for advancing the web of packaging material along a web advancement path and the
25 tube formed from the web of packaging material along a tube advancement path;

- a sterilizing apparatus for sterilizing the web of packaging material prior to its formation into the tube;

- a tube forming and sealing device at least
30 partially arranged within a first isolation chamber and being configured to form the tube from the advancing web of packaging material and to longitudinally seal the tube;

- a filling device for filling the tube with the

pourable product;

- a package forming unit being at least partially arranged within a second isolation chamber and being adapted to form, to transversally seal and to
5 transversally cut the tube of packaging material for obtaining the pillow packages; and

- a final folding unit arranged within the second isolation chamber and configured to treat and/or manipulate the pillow packages for obtaining the finalized
10 packages.

The known packaging machines function satisfying well, however, a desire is felt to further improve the known packaging machines. In particular, the desire is felt to further improve the cleanliness and sterility
15 and/or to facilitate the cleaning and/or sterilization of these packaging machines.

DISCLOSURE OF INVENTION

It is therefore an object of the present invention to provide an improved packaging machine, in particular
20 coming along with improved cleanliness and sterility and/or with a facilitated cleaning and/or sterilization capability.

According to the present invention, there is provided a packaging machine according to the independent claim.

25 Preferred embodiments are claimed in the dependent claims.

BRIEF DESCRIPTION OF THE DRAWINGS

A non-limiting embodiment of the present invention will be described by way of example with reference to the
30 accompanying drawings, in which:

Figure 1 is a schematic view of a packaging machine according to the present invention, with parts removed for clarity; and

Figure 2 is a schematic representation of the transformation of a semi-finalized pack into a finalized package, with parts removed for clarity.

BEST MODES FOR CARRYING OUT THE INVENTION

5 Number 1 indicates as a whole a packaging machine for producing sealed packages 2 of a pourable product, in particular a pourable food product such as pasteurized milk, fruit juice, wine, tomato sauce, etc.

10 Preferentially but not necessarily, packages 2 are produced from a tube 3 of a web 4 of packaging material.

Web 4 of packaging material has a multilayer structure (not shown), and comprises at least a layer of fibrous material, such as e.g. a paper or cardboard layer, and at least two layers of heat-seal plastic material, 15 e.g. polyethylene, interposing the layer of fibrous material in between one another. One of these two layers of heat-seal plastic material defines the inner face of package 2 eventually contacting the pourable product.

20 Preferably but not necessarily, web 4 also comprises a layer of gas- and light-barrier material, e.g. aluminum foil or ethylene vinyl alcohol (EVOH) film, in particular being arranged between one of the layers of the heat-seal plastic material and the layer of fibrous material. Preferentially but not necessarily, web 4 also comprises 25 a further layer of heat-seal plastic material being interposed between the layer of gas- and light-barrier material and the layer of fibrous material.

30 According to a preferred non-limiting embodiment, web 4 comprises a first face and a second face, in particular the first face being the face of web 4 forming the inner face of the formed package 2 eventually contacting the filled pourable food product.

According to a preferred non-limiting embodiment, a

typical package 2 extends along a longitudinal axis A and has a longitudinal seam portion 5 (extending along axis A and only partially shown) and a pair of transversal sealing bands 6, in particular a transversal top sealing band and a transversal bottom sealing band. In particular, package 2 has a substantially parallelepiped structure.

According to a preferred non-limiting embodiment, each package 2 comprises at least two transversal walls 7 (being transversal to longitudinal axis A) and being disposed at opposite sides of package 2 and a plurality of lateral walls 8 extending between transversal walls 7. In particular, one transversal wall 7 defines a bottom wall and the other transversal wall 7 defines a top wall of the respective package 2. Even more particular, the bottom wall has a support surface adapted to be placed on a (horizontal) plane, such as e.g. a shelf within a distribution point, and the top wall is opposed to the bottom wall.

With particular reference to Figure 1, packaging machine 1 is configured to produce sealed semi-finalized packs 9, such as e.g. pillow packs, being filled with the pourable product and to further treat and/or manipulate and/or form packs 9 for obtaining packages 2. In use, at first packs 9 are produced, followed by the formation of packages 2 from packs 9.

According to a preferred non-limiting embodiment, each pack 9 comprises at least a central main portion 10 and a plurality of flaps 11 protruding from central main portion 10.

Preferentially but not necessarily, each pack 9 extends along a longitudinal axis B and comprises a longitudinal sealing band 12 (extending along axis B) and two transversal sealing bands 13 disposed at opposite end

portions 14 of pack 9.

In particular, each longitudinal sealing band 12 and the respective transversal sealing bands 13 define respectively the corresponding longitudinal seam portion 5 and the corresponding transversal sealing bands 6 of the respective package 2 (obtained from the respective pack 9).

According to a preferred non-limiting embodiment, end portions 14 of each pack 9 taper from the respective central main portion 10 to the respective transversal sealing band 13.

According to a preferred non-limiting embodiment, each end portion 14 carries at least two flaps 11, in particular at opposite lateral edges thereof.

According to a preferred non-limiting embodiment, packaging machine 1 is configured to manipulate and/or form and/or process packs 9 such that flaps 11 are folded and sealed onto at least one of lateral walls 8 and/or onto one of transversal walls 7 of the respective package 2. According to the non-limiting embodiment shown, two flaps 11 are sealed onto two corresponding lateral walls 8 and two flaps 11 are sealed onto one transversal wall 7 of the respective package 2 (see e.g. Figure 2).

With particular reference to Figure 1, packaging machine 1 comprises at least:

- an isolation housing 18;
- a formation apparatus 19 at least partially arranged within isolation housing 18 and being configured to form and/or obtain packs 9 of the pourable product;
- an outlet conveying unit 20 configured to receive packs 9 within isolation housing 18 and to advance packs 9 out of isolation housing 18 and to a transfer station 21; and

- a final folding unit 22 arranged at transfer station 21 and configured to receive packs 9 from outlet conveying unit 20 and to treat and/or manipulate packs 9 such to obtain packages 2.

5 According to a preferred non-limiting embodiment, packaging machine 1 also comprises a conveying device 24 configured to advance web 4 along a web advancement path P at least to a tube forming station 23 at which web 4 is formed, in use, into tube 3 and for advancing tube 3 along
10 a tube advancement path Q.

According to a preferred non-limiting embodiment, isolation housing 18 comprises at least a first isolation chamber 25 having a first inner environment 26 and a second isolation chamber 27 having a second inner
15 environment 28.

According to a preferred non-limiting embodiment, second isolation chamber 27 and second inner environment 28 are arranged downstream of respectively first isolation chamber 25 and first inner environment 26 along tube
20 advancement path Q. In particular, in use, tube 3 passes from first inner environment 26 into second inner environment 28.

According to a preferred non-limiting embodiment, packaging machine 1 further comprises a safety chamber 29
25 distinct from isolation housing 18, in particular from first isolation chamber 25 and second isolation chamber 27, and housing at least a portion of final folding unit 22 such that final folding unit 22 treats and/or manipulates, in use, packs 9 within safety chamber 29 for
30 obtaining packages 2.

Preferentially but not necessarily, safety chamber 29 is transversally spaced apart from isolation housing 18, in particular from second isolation chamber 27.

According to a preferred non-limiting embodiment, safety chamber 29 is detached from isolation housing 18, in particular from first isolation chamber 25 and second isolation chamber 27; i.e. there is no direct mechanical
5 contact between safety chamber 29 and isolation housing 18.

According to an alternative non-limiting embodiment, safety chamber 29 is in contact with at least second isolation chamber 27.

10 According to a preferred non-limiting embodiment, packaging machine 1 further comprises a connecting channel 30 interposed between isolation housing 18, in particular second isolation chamber 27, and safety chamber 29.

According to a preferred non-limiting embodiment,
15 connecting channel 30 houses at least an (intermediate) portion of outlet conveying unit 20 for advancing, in use, packs 9 between isolation housing 18, in particular second isolation chamber 27, and safety chamber 29 within connecting channel 30.

20 In particular, connecting channel 30 encloses an advancement space 31 within which packs 9 advance, in use, between isolation housing 18, in particular second isolation chamber 27, and final folding unit 22 and/or safety chamber 29.

25 According to a preferred non-limiting embodiment, formation apparatus 19 is configured to form web 4 into tube 3 and to longitudinally seal tube 3, to fill tube 3 with the pourable product and to form, transversally seal and, in particular to also transversally cut tube 3, for
30 obtaining and/or producing packs 9.

With particular reference to Figure 1, formation apparatus 19 comprises at least:

- a tube forming and sealing device 32 at least

partially arranged within first isolation chamber 25 and being configured to form and longitudinally seal tube 3 at tube forming station 23, in particular within at least a portion of first isolation chamber 25, even more particular within first inner environment 26;

- a filling device 33 for filling tube 3 with the pourable product; and

- a package forming unit 34 at least partially arranged within second isolation chamber 27 and/or second inner environment 28 and being adapted to (configured to) at least form and transversally seal tube 3, preferentially to also transversally cut tube 3, in particular during advancement of tube 3 along tube advancement path Q, within second inner environment 28 for obtaining and/or producing packs 2.

In particular, package forming unit 34 is arranged downstream of first isolation chamber 25 and tube forming and sealing device 32 along path Q.

In particular, tube 3 extends along a longitudinal axis, in particular having a vertical orientation.

According to a preferred non-limiting embodiment, packaging machine 1 further comprises a sterilization apparatus for sterilizing at least a portion of web 4 at a sterilization station arranged upstream of tube forming station 23 along web advancement path P.

Preferentially but not necessarily, the sterilization apparatus is configured to sterilize web 4 by means of physical sterilization such as a sterilization irradiation, in particular an electromagnetic irradiation, even more particular electron beam irradiation.

Alternatively, or in addition, the sterilization apparatus could be configured to sterilize web 4 by means

of chemical sterilization, in particular by means of hydrogen peroxide.

According to a preferred non-limiting embodiment, packaging machine 1 also comprises a magazine unit adapted to host and to provide for web 4 at a host station. In particular, conveying device 24 is configured to advance web 4 from the host station to tube forming station 23 and, in particular through the sterilization station.

Preferentially but not necessarily, conveying device 24 is adapted to advance tube 3 and any intermediate of tube 3 in a manner known as such along path Q, in particular from tube forming station 23 through first inner environment 26 and towards and at least partially through second inner environment 28. In particular, with intermediates of tube 3 any configuration of web 4 is meant prior to obtaining the tube structure and after folding of web 4 by tube forming and sealing device 32 has started. In other words, the intermediates of tube 3 are a result of the gradual folding of web 4 so as to obtain tube 3, in particular by overlapping opposite lateral edges of web 4 with one another.

According to a preferred non-limiting embodiment, first isolation chamber 25 separates first inner environment 26 from an outer environment, in particular for allowing to form and to fill tube 3 within a controlled atmosphere. In particular, first inner environment 26 contains a sterile gas.

According to a preferred non-limiting embodiment, packaging machine 1 also comprises an atmosphere control unit configured to control a gas atmosphere within at least a portion of isolation housing 18, in particular first isolation chamber 25.

Preferentially but not necessarily, the atmosphere

control unit is configured to control a positive pressure within inner environment 24 being larger than the ambient pressure, and in particular to also introduce a sterile gas into at least inner environment 24.

5 With particular reference to Figure 1, filling device 33 comprises at least a filling pipe 35 being in fluid connection or being controllable to be in fluid connection with a pourable product storage tank (not shown and known as such) and partially extending within first isolation
10 chamber 25, in particular first inner environment 26. In particular, in use, filling pipe 35 is partially placed within tube 3 for feeding the pourable product into the, in use, advancing tube 3.

 With particular reference to Figure 1, tube forming
15 and sealing device 32 comprises at least a tube forming assembly configured to form tube 3 from web 4, in particular by overlapping the respective lateral edges of web 4, and at least a sealing head 37 configured to longitudinally seal tube 3, in particular along the
20 portion of tube 3 obtained by the overlapping of the lateral edges of web 4.

 Preferentially but not necessarily, the tube forming assembly and sealing head 37 are arranged within first
25 isolation chamber 25, in particular within first inner environment 26.

 Preferentially but not necessarily, the tube forming assembly comprises at least a plurality of forming ring assemblies 38, in the particular example shown two, being adapted to fold web 4 gradually into tube 3. In
30 particular, forming ring assemblies 38 are arranged within parallel and spaced apart planes, in particular being orthogonal to a longitudinal axis of first isolation chamber 25, even more specifically having a substantially

horizontal orientation.

Preferentially but not necessarily, tube forming and sealing device 32 also comprises a pressuring assembly configured to exert a mechanical force on tube 3, in particular for promoting the longitudinal sealing of tube 3. In particular, the pressuring assembly is associated to the forming ring assembly 38 being arranged downstream of the other forming ring assembly 38 along web advancement path P and/or tube advancement path Q.

According to a preferred non-limiting embodiment, package forming unit 34 comprises a plurality of pairs of at least one respective operative assembly (not shown and known as such) and at least one counter-operative assembly (not shown and known as such); and

- a conveying unit (not shown and known as such) adapted to advance the operative assemblies and the respective counter-operative assemblies along respective conveying paths.

Preferentially but not necessarily, each operative assembly is adapted to cooperate, in use, with the respective counter-operative assembly of the respective pair for forming, transversally sealing and transversally cutting tube 3 for obtaining one respective pack 9, in particular when, in use, advancing along a respective operative portion of the respective conveying path.

Preferentially but not necessarily, each operative assembly and each counter-operative assembly comprises:

- a half-shell adapted to contact tube 3 and to at least partially define the shape of packs 9 and/or packages 2;

- one of a sealing element and a counter-sealing element, adapted to transversally seal tube 3 in a known manner, in particular between adjacent packs 9; and

- one of a cutting element (not shown and known as such) and a counter-cutting element (not shown and known as such) for transversally cutting tube 3 between adjacent packs 9 in a manner known as such.

5 According to a preferred non-limiting embodiment, first isolation chamber 25 comprises at least an outlet opening configured to allow for the passage of tube 3 from first inner environment 26 into second inner environment 28, and in particular an inlet opening opposed to the
10 outlet opening and configured to allow for the introduction of web 4 into first inner environment 26.

Preferentially but not necessarily, first isolation chamber 25 comprises a first transversal delimiting wall 39 carrying and/or having the outlet opening and a
15 plurality of lateral walls 40 extending from the first transversal delimiting wall 39 along a first direction, in particular first direction being an upward direction.

Preferentially but not necessarily, second isolation chamber 27 comprises a plurality of lateral walls 41, in
20 particular extending from first transversal delimiting wall 39 along a second direction opposite to the first direction, in particular second direction being a downward direction.

According to a preferred non-limiting embodiment,
25 first transversal delimiting wall 39 separates first inner environment 26 from second inner environment 28.

Preferentially but not necessarily, first isolation chamber 25 and/or second isolation chamber 27 comprise(s)
30 sealing means for sealing, in use, in collaboration with tube 3, the outlet opening for substantially limiting and/or impeding any gas exchange between second inner environment 28 and first inner environment 26.

According to a preferred non-limiting embodiment,

isolation housing 18, in particular second isolation chamber 27 comprises an outlet aperture 42 configured to allow for the outlet of packs 9 from isolation housing 18, in particular from second isolation chamber 27 and/or
5 second inner environment 28. In particular, outlet conveying unit 20 extends through outlet aperture 42 and is configured to advance packs 9 out of second isolation chamber 27 through the outlet aperture 42.

Preferentially but not necessarily, one of lateral
10 walls 41 comprises outlet aperture 42.

Preferentially but not necessarily, according to an alternative non-limiting embodiment not shown, safety chamber 29 is in contact with one lateral wall 41, in particular the one comprising outlet aperture 42.

15 According to a preferred non-limiting embodiment, outlet conveying unit 20 is configured to advance packs 9 along an advancement path R from a receiving station 43, at which outlet conveying unit 20 receives, in use, packs 9, to transfer station 21.

20 According to a preferred non-limiting embodiment, outlet conveying unit 20 comprises at least one belt conveyor being at least partially arranged within second inner environment 28.

Alternatively, or in addition, outlet conveying unit
25 20 could also comprise conveyors of another type.

Alternatively, or in addition, outlet conveying unit
20 could comprise a plurality of belt conveyors being arranged in succession of one another and extending at least between receiving station 43 and transfer station
30 21.

According to a preferred non-limiting embodiment and with particular reference to Figure 2, final folding unit 22 is configured to manipulate and/or process packs 9 such

so as to form and/or shape at least the respective central main portions 10 (into the desired form and/or shape of the respective package 2) and to control and/or determine the relative position of flaps 11 with respect to the
5 respective central main body 10.

Preferentially but not necessarily, final folding unit 22 is configured to seal each flap 11 onto the respective central main body 10 such that each flap 11 is sealed to one of transversal walls 7 and/or lateral walls
10 8 of the respective package 2.

In particular, final folding unit 22 is of the known type, as e.g. described in EP-A-0887261 or EP-A-2586719 or WO-A-2008122623 or any other kind.

According to a preferred non-limiting embodiment,
15 final folding unit 22 comprises at least:

- a conveying assembly configured to advance packs 9 along a final advancement path; and
- at least one treatment unit configured to form and/or shape central main portion 10 and/or for folding
20 and sealing flaps 11 onto the respective central main portion 10 during the advancement of packs 9 along the final advancement path.

According to a preferred non-limiting, the conveying assembly comprises a plurality of retaining pockets
25 configured to retain at least one respective pack 9 during advancement of packs 2 along the final advancement path.

According to a non-limiting embodiment, final folding unit 22 comprises a plurality of treatment units each one being associated to one respective retaining
30 pocket and/or being arranged along the final advancement path.

In use, packaging machine 1 forms packages 2 filled with the pourable product.

In particular, the method of forming packages 2 comprises the main steps of:

- forming packs 9 by means of formation apparatus 19;
- 5 - conveying packs 9 to final folding unit 22; and
- final folding pack 9 by means of final folding unit 22 for obtaining packages 2 (see Figure 2).

According to a preferred non-limiting embodiment, the method also comprises the main step of transferring
10 packs 9 to outlet conveying unit 20, in particular at receiving station 43.

According to a preferred non-limiting embodiment, the method also comprises the main step of transferring packs 9 to final folding unit 22 at transfer station.

15 In particular, the main step of final folding is executed after the main step of forming packs 9.

In more detail, the main step of forming packs 9, comprises at least the steps of:

- advancing web 4 along advancement path P;
- 20 - folding web 4, in particular within first isolation chamber 25 and/or first inner environment 26, into tube 3 at tube forming station 23;
- longitudinally sealing tube 3, in particular within first isolation chamber 25;
- 25 - filling tube 3 with the pourable product;
- advancing tube 3 along tube advancement path Q, in particular through a portion of first inner environment 26 and/or first isolation chamber 25 towards and at least partially through second inner environment 28 and/or
30 second isolation chamber 27; and
- obtaining packs 9 from tube 3 by forming, transversally sealing and transversally cutting tube 3 within second inner environment 28 and during advancement

of tube 3 along tube advancement path Q.

Preferentially but not necessarily, the main step of forming also comprises the step of sterilizing web 4 at the sterilization station.

5 According to a preferred non-limiting embodiment, during the step of advancing web 4, conveying device 24 advances web 4 along web advancement path P and, in particular from the host station to at least tube forming station 23.

10 According to a preferred non-limiting embodiment, during the step of folding tube 3, tube forming and sealing device 32 gradually overlaps the opposite lateral edges of web 4 with one another so as to form the longitudinal seal.

15 According to a preferred non-limiting embodiment, during the step of longitudinally sealing tube 3, tube forming and sealing device 32 seals the longitudinal seal by directing heat onto the longitudinal seal, in particular by sealing head 37 transferring thermal energy
20 onto the longitudinal seal.

 According to a preferred non-limiting embodiment, during the step of advancing tube 3, conveying device 24 advances tube 3 (and any intermediates of tube 3), in particular through first isolation chamber 25, along path
25 Q into and partially through second isolation chamber 27.

 According to a preferred non-limiting embodiment, during the step of filling tube 3, filling device 33 fills the pourable product into the longitudinally sealed tube 3. In particular, the pourable product is directed into
30 tube 3 through filling pipe 35.

 According to a preferred non-limiting embodiment, during the step of sterilizing web 4 a sterilizing irradiation, in particular electromagnetic irradiation,

even more particular electron beam irradiation, is directed onto at least the first face, preferentially also onto the second face, of web 4.

According to a preferred non-limiting embodiment, 5 the step of sterilizing is executed prior to the step of folding.

According to a preferred non-limiting embodiment, during the step of obtaining packs 9, package forming unit 34 forms, transversally seals and transversally cuts tube 10 3, in particular between successive packs 9.

Preferentially but not necessarily, during the step of obtaining packs 9, each operative assembly and the respective counter-operative assembly advance along the respective conveying paths and form, transversally seal 15 and transversally cut tube 3 in cooperation while advancing along the respective operative portions.

According to a preferred non-limiting embodiment, during the main step of transferring packs 9 to outlet conveying unit 20, packs 9 are transferred to outlet 20 conveying unit 20 at receiving station 43 by means of gravity. Alternatively, packs 9 could be transferred by means of transfer elements.

According to a preferred non-limiting embodiment, during the main step of transferring packs 9 to final 25 folding unit 22, packs 9 are transferred to the conveying assembly, in particular to one respective retaining pocket.

According to a preferred non-limiting embodiment and with particular reference to Figure 2, during the main 30 step of final folding packs 9, the respective central main portions 10 are formed and/or the respective flaps 11 are folded and sealed onto the respective central main portions 10.

Preferentially but not necessarily, the main step of final folding packs 9, comprises the steps of conveying packs 9 along the final advancement path (by means of the conveying assembly) and to treat packs 9 during advancement along the final advancement path for obtaining packages 2.

In particular, during the step of treating packs 9, the at least one treatment unit forms and/or shapes the respective central main portions 10 and/or folds and seals the respective flaps 11 onto the respective central main portions 10.

The advantages of packaging machine 1 according to the present invention will be clear from the foregoing description.

In particular, by placing final folding unit 22 outside of isolation housing 18, in particular outside of second inner environment 28, the overall cleaning and/or sterilization process, as e.g. done during a cleaning-in-place and/or sterilization-in-place process, of packaging machine 1 is facilitated. This is e.g. possible as the dimension of second isolation chamber 27 can be reduced with respect to the state-of-the-art packaging machines and as the cleaning and/or sterilization process does not require a cleaning and/or sterilization of final folding unit 22 as currently required.

Another advantage is seen in the possibility of cleaning second isolation chamber 27 and/or package forming unit 34 independently from safety chamber 29 and/or final folding unit 22. Furthermore, this also allows to apply different cleaning frequencies for the cleaning of second isolation chamber 27 and/or package forming unit 34 and the cleaning of safety chamber 29 and/or final folding unit 22.

A further advantage resides in the possibility of facilitating the construction of final folding unit 22 as it is not required to optimize final folding unit 22 for cleaning and/or sterilization purposes.

5 Clearly, changes may be made to packaging machine 1 as described herein without, however, departing from the scope of protection as defined in the accompanying claims.

CLAIMS

1.- A packaging machine (1) for producing sealed packages (2) of a pourable product comprising at least:

- an isolation housing (18);

5 - a formation apparatus (19) at least partially arranged within the isolation housing (18) and being configured to form and/or obtain sealed semi-finalized packs (9) of the pourable product;

10 - an outlet conveying unit (20) configured to receive the sealed semi-finalized packs (9) within the isolation housing (18) and to advance the sealed semi-finalized packs (9) out of the isolation housing (18) and to a transfer station (21); and

15 - a final folding unit (22) arranged at the transfer station (21) and configured to receive the sealed semi-finalized packs (9) from the outlet conveying unit (20) and to treat and/or manipulate the sealed semi-finalized packs (9) such to obtain the packages (2).

20 2.- A packaging machine according to claim 1, and further comprising a conveying device (22) for advancing a web (4) of packaging material along a web advancement path (P) at least to a tube forming station (23) at which the web (4) of packaging material is formed, in use, into a tube (3) and for advancing the tube (3) along a tube advancement path (Q);

 wherein the isolation housing (18) comprises at least:

 - a first isolation chamber (25) having a first inner environment (26); and

30 - a second isolation chamber (27) having a second inner environment (28);

 wherein the formation apparatus (19) comprises at least:

- a tube forming and sealing device (32) being at least partially arranged within the first isolation chamber (25) and being configured to form the tube (3) at the tube forming station (23) and to longitudinally seal
5 the tube (3) within the first inner environment (26);

- a filling device (33) for filling the tube (3) with the pourable product; and

- a package forming unit (34) at least partially arranged within the second isolation chamber (27) and
10 being adapted to form, transversally seal and transversally cut the tube (3) within the second inner environment (28) so as to obtain the sealed semi-finalized packs (9);

wherein at least a portion of the outlet conveying
15 unit (20) is arranged within the second isolation chamber (27) for receiving the sealed semi-finalized packs (9) and for advancing the sealed semi-finalized packs (9) out of the second isolation chamber (27) and to the transfer station (21).

20 3.- Packaging machine according to claim 2, wherein the first isolation chamber (25) comprises an outlet opening configured to allow for the passage of the tube (3) from the first inner environment (26) into the second inner environment (28).

25 4.- Packaging machine according to claim 2 or 3, and further comprising an atmosphere control unit configured to control a positive pressure within the first inner environment (26) being larger than the ambient pressure.

30 5.- Packaging machine according to any one of the preceding claims, and further comprising a safety chamber (29) distinct from the isolation housing (18) and housing at least a portion of the final folding unit (22);

wherein the final folding unit (22) is configured to

treat and/or manipulate the sealed semi-finalized packs (9) within the safety chamber (29).

6.- Packaging machine according to claim 6, wherein the safety chamber (29) is transversally spaced apart from the isolation housing (18).

7.- Packaging machine according to claim 5 or 6, wherein the safety chamber (29) is detached from the isolation housing (18).

8.- Packaging machine according to any one of claims 5 to 7, and further comprising a connecting channel (30) interposed between the isolation housing (18) and the safety chamber (29) and housing at least a portion of the outlet conveying unit (20) for advancing, in use, the sealed semi-finalized packs (9) between the isolation housing (18) and the safety chamber (29) within the connecting channel (30).

9.- Packaging machine according to claim 5 or 6, wherein the safety chamber (29) is in contact with at least a lateral wall (41) of the isolation housing (18).

10.- Packaging machine according to any one of the preceding claims, wherein each sealed semi-finalized pack (9) comprises a central main portion (10) and at least one flap (11) protruding from the respective central main portion (10);

wherein the final folding unit (22) comprises at least:

- a conveying assembly configured to advance the semi-finalized packs (9) along a final advancement path; and

- at least one treatment unit configured to form and/or shape each central main portion (10) and/or for folding and sealing the respective at least one flap (11) onto the respective central main portion (10) during the

advancement of the sealed semi-finalized packs (9) along the final advancement path.

11.- Packaging machine according to any one of the preceding claims, wherein the isolation housing (18) comprises an outlet aperture configured to allow for the outlet of the sealed semi-finalized packs (9) out of the isolation housing (10).

12.- Packaging machine according to claim 11, wherein the isolation housing (18) comprises at least one lateral wall (41) having the outlet aperture.

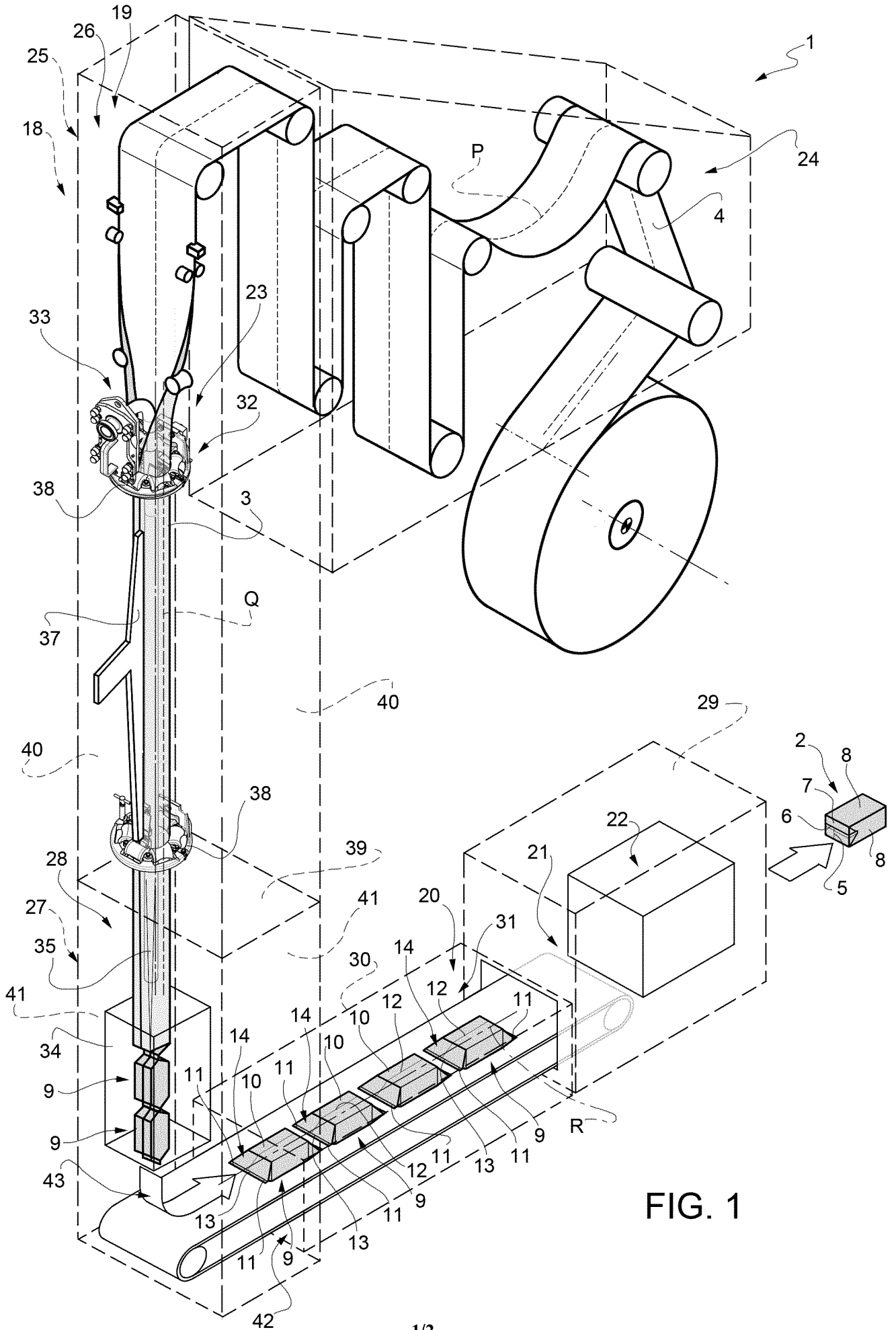
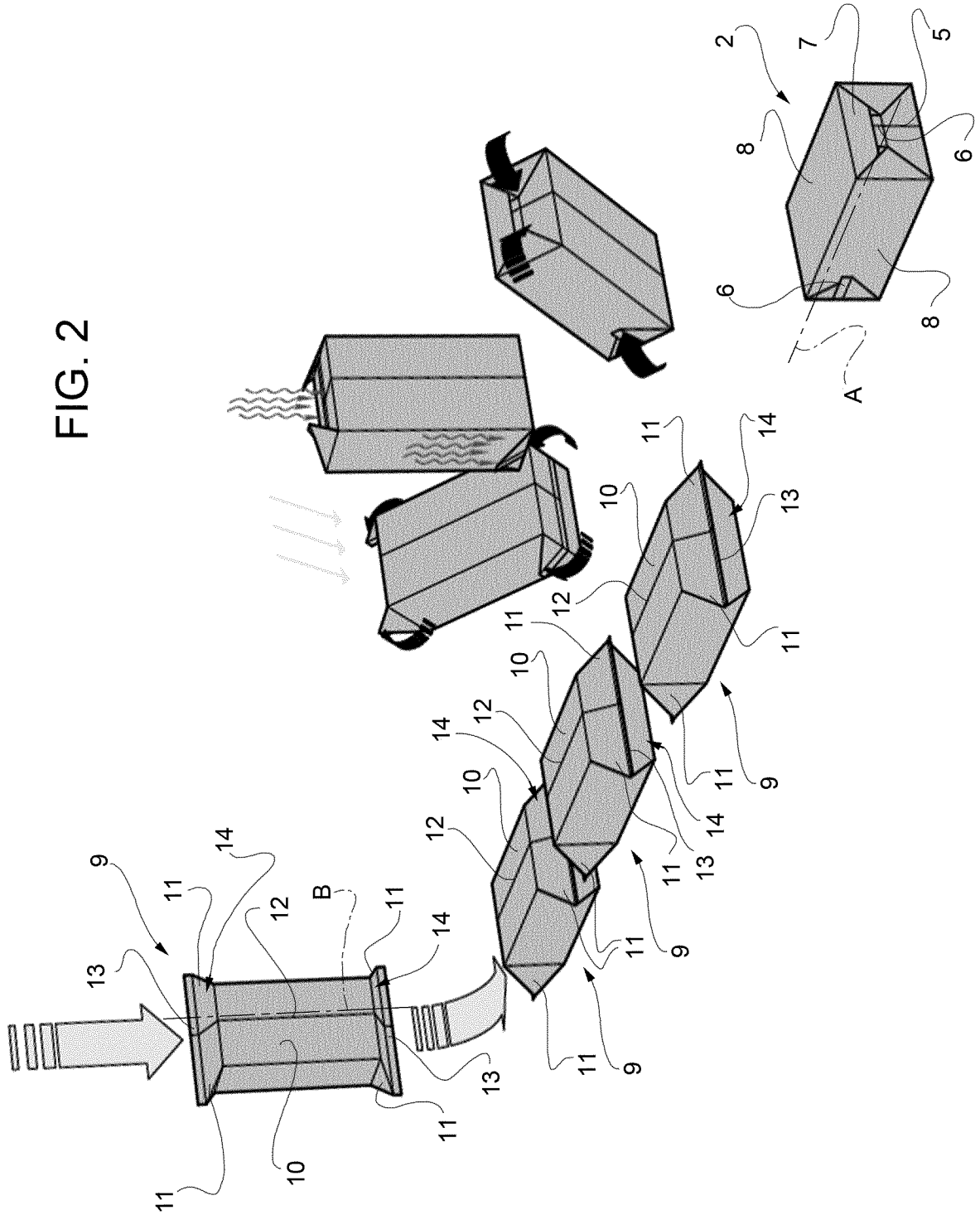

FIG. 1

FIG. 2



INTERNATIONAL SEARCH REPORT

International application No
PCT/EP2020/055568

A. CLASSIFICATION OF SUBJECT MATTER
INV. B65B9/20 B65B55/02
ADD.
According to International Patent Classification (IPC) or to both national classification and IPC

B. FIELDS SEARCHED
Minimum documentation searched (classification system followed by classification symbols)
B65B

Documentation searched other than minimum documentation to the extent that such documents are included in the fields searched

Electronic data base consulted during the international search (name of data base and, where practicable, search terms used)
EPO-Internal, WPI Data

C. DOCUMENTS CONSIDERED TO BE RELEVANT

Category*	Citation of document, with indication, where appropriate, of the relevant passages	Relevant to claim No.
X A	GB 1 220 959 A (SERES SOC D ETUDES ET DE REALI [FR]) 27 January 1971 (1971-01-27) page 1, line 63 - page 2, line 45; figures 1-3	1,11 2-10,12
A	----- EP 3 081 497 A1 (TETRA LAVAL HOLDINGS & FINANCE [CH]) 19 October 2016 (2016-10-19) paragraphs [0024] - [0039]; figure 1	1-12
A	----- GB 1 513 266 A (ALPURA KORECO AG) 7 June 1978 (1978-06-07) page 1, line 94 - page 2, line 39; figure 1	1-12
A	----- GB 1 531 332 A (BELGIQUE PAPETERIES) 8 November 1978 (1978-11-08) page 2, lines 14-54; figure 3	1-12

Further documents are listed in the continuation of Box C.

See patent family annex.

* Special categories of cited documents :

- "A" document defining the general state of the art which is not considered to be of particular relevance
- "E" earlier application or patent but published on or after the international filing date
- "L" document which may throw doubts on priority claim(s) or which is cited to establish the publication date of another citation or other special reason (as specified)
- "O" document referring to an oral disclosure, use, exhibition or other means
- "P" document published prior to the international filing date but later than the priority date claimed

- "T" later document published after the international filing date or priority date and not in conflict with the application but cited to understand the principle or theory underlying the invention
- "X" document of particular relevance; the claimed invention cannot be considered novel or cannot be considered to involve an inventive step when the document is taken alone
- "Y" document of particular relevance; the claimed invention cannot be considered to involve an inventive step when the document is combined with one or more other such documents, such combination being obvious to a person skilled in the art
- "&" document member of the same patent family

Date of the actual completion of the international search 25 March 2020	Date of mailing of the international search report 03/04/2020
---	---

Name and mailing address of the ISA/ European Patent Office, P.B. 5818 Patentlaan 2 NL - 2280 HV Rijswijk Tel. (+31-70) 340-2040, Fax: (+31-70) 340-3016	Authorized officer Kulhanek, Peter
--	--

INTERNATIONAL SEARCH REPORT

Information on patent family members

International application No PCT/EP2020/055568

Patent document cited in search report	Publication date	Patent family member(s)	Publication date	
GB 1220959	A	27-01-1971	DE 1767887 A1	30-09-1971
			FR 94399 E	08-08-1969
			GB 1220959 A	27-01-1971
			SE 347715 B	14-08-1972
			US 3583132 A	08-06-1971

EP 3081497	A1	19-10-2016	CN 107406160 A	28-11-2017
			EP 3081497 A1	19-10-2016
			JP 6402262 B2	10-10-2018
			JP 2018511534 A	26-04-2018
			US 2018057199 A1	01-03-2018
			WO 2016165922 A1	20-10-2016

GB 1513266	A	07-06-1978	AU 8664275 A	02-06-1977
			BE 835638 A	17-05-1976
			BR 7507643 A	10-08-1976
			CA 1029168 A	11-04-1978
			CH 587153 A5	29-04-1977
			DE 2507790 A1	20-05-1976
			ES 442741 A1	01-04-1977
			FR 2291767 A1	18-06-1976
			GB 1513266 A	07-06-1978
			IT 1048719 B	20-12-1980
			JP S5173120 A	24-06-1976
			JP S6013699 B2	09-04-1985
			NL 7513468 A	21-05-1976
			SE 425050 B	30-08-1982
			SU 604462 A3	25-04-1978
			ZA 7507095 B	26-01-1977

GB 1531332	A	08-11-1978	AT 348431 B	12-02-1979
			CH 610844 A5	15-05-1979
			DE 2602531 A1	29-07-1976
			ES 444524 A1	16-06-1977
			FR 2298482 A1	20-08-1976
			GB 1531332 A	08-11-1978
			IT 1056594 B	20-02-1982
			JP S5198589 A	30-08-1976
			JP S6015531 B2	19-04-1985
			NL 7600736 A	27-07-1976
SE 426467 B	24-01-1983			
