

(21) Application No: 1120962.4
(22) Date of Filing: 06.05.2009
Date Lodged: 06.12.2011

(86) International Application Data:
PCT/IB2009/051850 En 06.05.2009

(87) International Publication Data:
WO2009/136367 En 12.11.2009

(71) Applicant(s):
David John Drake Hawkins
5 Gables Way, Rondebosch, Cape Town 7700,
South Africa

(72) Inventor(s):
David John Drake Hawkins

(74) Agent and/or Address for Service:
Keltie LLP
Fleet Place House, 2 Fleet Place, LONDON,
EC4M 7ET, United Kingdom

(51) INT CL:
E02D 29/14 (2006.01) E01C 23/09 (2006.01)

(56) Documents Cited by ISA:
FR 002592901 A1 JP 050179607 A
JP 2005290768 A US 6161985 A
US 5564855 A US 5362175 A
US 4924951 A US 3974599 A
US 3250190 A US 20030235469 A1
US 20030222495 A1

(58) Field of Search by ISA:
INT CL E01C, E02D, E03F
Other: EPODOC & WPI

(54) Title of the Invention: **A method of constructing a manhole in a road and a manhole plug**
Abstract Title: **A method of constructing a manhole in a road and a manhole plug**

(57) A method of constructing a manhole in a road (26) which involves the replacement of an existing manhole with a new manhole, includes providing a manhole plug (10) which is disc-shaped and which comprises a cast iron manhole frame (12) and a surrounding moulding (13) in which the frame is embedded. The existing manhole is removed by introducing a cutting tool into the manhole and making an annular undercut in the road under the existing manhole and thereafter, using a barrel cutter, making a cylindrical cut in a direction perpendicular to the road surface around the existing manhole to the depth of the undercut. The existing manhole and surrounding road material is then removed leaving behind a hole into which the manhole plug (10) is fitted.

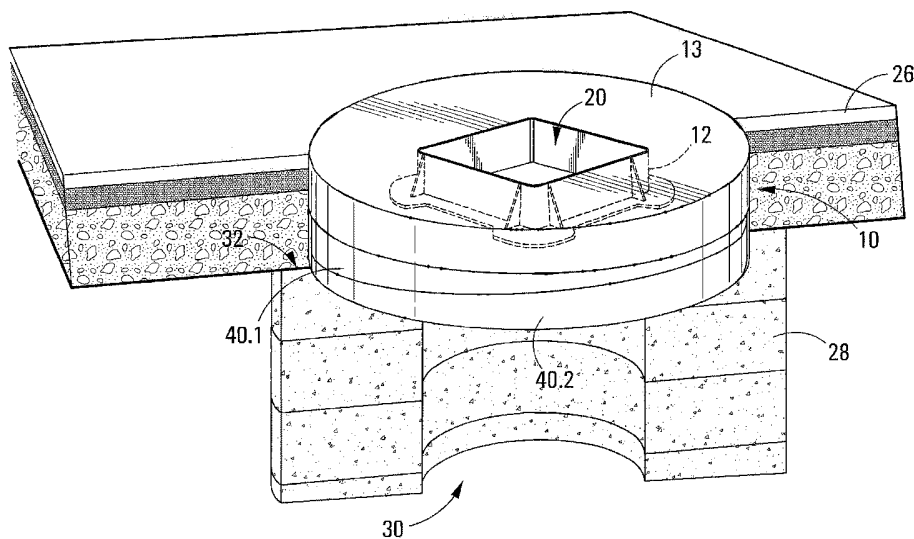

FIG 8