

(No Model.)

C. F. SCHWAB.
VEHICLE DASH SEWING MACHINE.

No. 551,791.

Patented Dec. 24, 1895.

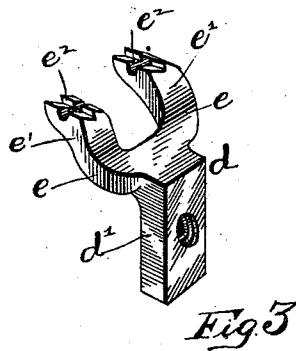
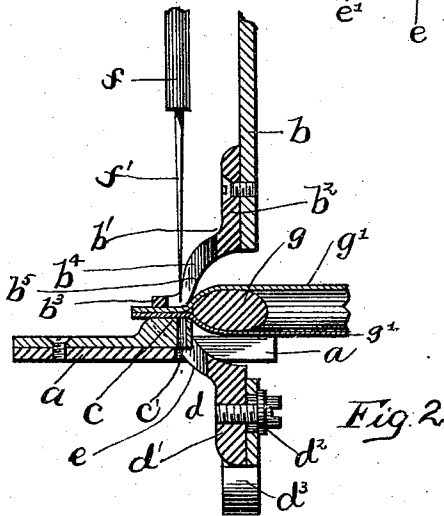
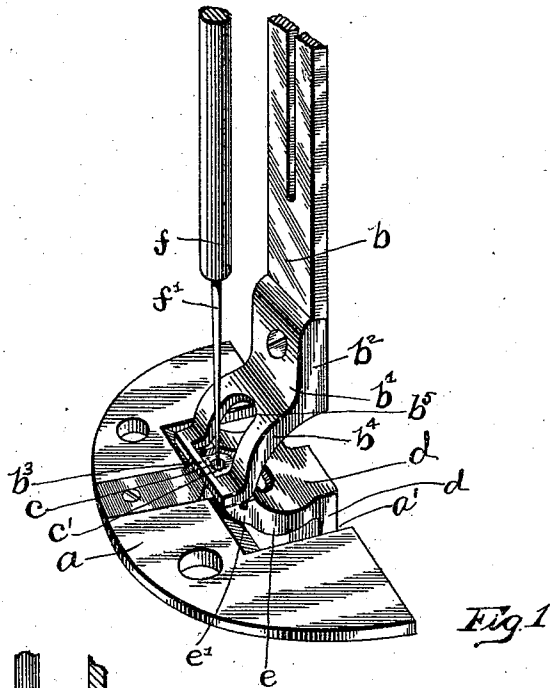

WITNESSES:

H. B. Brackham
A. L. Phelps

INVENTOR

Charles F. Schwab

BY

C. C. Shepherd
ATTORNEY

UNITED STATES PATENT OFFICE.

CHARLES F. SCHWAB, OF COLUMBUS, OHIO.

VEHICLE-DASH SEWING-MACHINE.

SPECIFICATION forming part of Letters Patent No. 551,791, dated December 24, 1895.

Application filed July 27, 1895. Serial No. 557,332. (No model.)

To all whom it may concern:

Be it known that I, CHARLES F. SCHWAB, a citizen of the United States, residing at Columbus, in the county of Franklin and State of Ohio, have invented a certain new and useful Improvement in Vehicle-Dash Sewing-Machines, of which the following is a specification.

My invention relates to the improvement of vehicle-dash sewing-machines, and the objects of my invention are to provide improved means for stitching the dash-leather along the outer side of the frame thereof and to produce other improvements in details of construction and arrangement of parts which will be more fully pointed out hereinafter. These objects I accomplish in the manner illustrated in the accompanying drawings, in which—

Figure 1 is a view in perspective of the throat-plate, showing in conjunction therewith those parts which are necessary in carrying out my invention. Fig. 2 is a central vertical section of the same, and Fig. 3 is a detail view in perspective of the feed-dog which I employ, as hereinafter described.

Similar letters refer to similar parts throughout the several views.

a represents the throat-plate which is secured to the table-top of the machine adjacent to the forward end thereof in the usual manner. This throat-plate is, as shown in the drawings, substantially in the form of a half-disk, the straight side of which is provided with a central recess *a'*.

b represents the upright presser-bar which extends downward in front of the usual machine-arm and to which is imparted in the usual manner a vertical reciprocating motion. This presser-bar is provided on its lower end portion with an extension or presser-foot *b'*, the peculiar form of which facilitates the carrying out of the objects of my invention. The shank *b²* or that portion of the presser-foot which is connected with the bar *b* extends, as shown, vertically downward, and from the lower end of said shank portion said foot is extended and curved outward and thence downward, terminating in a short horizontal lip portion *b³*. Through this forwardly or outwardly inclined and curved foot portion *b⁴* is formed an opening *b⁵*, said opening

being extended, as shown, into the lip portion *b³*. As indicated in the drawings the portion *b⁴* of the presser-foot is adapted to project over the recess *a'* of the throat-plate *a*.

c represents a needle-guide lug which projects over the edge of the recess *a* and is provided with a needle-guide opening *c'* which is thus arranged beneath the opening *b⁵* of the presser-foot.

d represents the feed-dog, said feed-dog consisting, as shown, of a vertical shank portion *d'* which is adapted to be secured as indicated at *d²* to the usual feed-lever *d³*, which forms in the well-known manner a part of the operating mechanism which is beneath the surface of the table-top and which is adapted to impart to said feed-dog the usual oscillatory or feeding movement. The feed-dog *d* further consists in a forwardly and upwardly curved and inclined feed-head *e* which is formed integral with the upper end of said shank portion *d'*. As indicated in the drawings, this head *e* is bifurcated, resulting in the formation of two separated and upwardly and outwardly curved feed-fingers *e'*, the upper ends of which are toothed to facilitate their engagement with the goods to be stitched, as indicated at *e²*. When secured to the feed-lever in the manner hereinbefore described, the curved and bifurcated feed-head is adapted to extend upward into and through the recess *a'* of the throat-plate, its engaged end portions being thus brought immediately beneath the lip portion *b³* of the presser-foot on opposite sides of the presser-foot opening *b⁵*, and on opposite sides of the needle-guide lug *c*.

f represents the needle-bar and *f'* the needle which is carried thereby and which is adapted to work backward and forward in the guide-opening *c'* and through the goods which pass between the presser-foot lip *b³* and feed-head *e*.

In operation the end or side of the dash-frame which is indicated at *g* is, as shown in Fig. 2 of the drawings, caused to rest on the plate *a* and extend over the rear portion of the recess *a'* thereof. In this manner the dash-frame arm is brought between the outwardly-curved foot *b⁴* and feed-head *e*, while the projecting edges of the dash-frame cover *g'* are, as shown in said Fig. 2, adapted to be

closed together between the ends of the feed-fingers e' and the forwardly-extending lip of the presser-foot. It will be observed that the forms of said presser-foot and feed-head fingers are such as to admit of the outer edge portion of the dash-frame arm g fitting closely up to the needle-guide opening e' , thus admitting of the dash-frame cover being stitched closely to said frame.

10 From the construction and operation which I have described it will be seen that the peculiar forms and arrangement of the throat-plate, feed-head and presser-foot not only provide a desirable and convenient support
15 for the dash-frame, but that by their use the difficulties heretofore experienced in stitching the dash-cover adjacent to the edges of the dash-frame arms is entirely obviated.

Having now fully described my invention,
20 what I claim, and desire to secure by Letters Patent, is—

1. In a vehicle dash sewing machine the combination with a throat plate a having a
25 recess a' in one side thereof and a needle guide projecting from said plate into said recess, of a vertically movable presser bar b , a

presser foot b^2 carried thereon, said foot being inclined forwardly and provided with a straight lip portion b^3 and an opening b^5 therein and a feed dog d projecting within said plate recess a' and adapted to have a feeding motion imparted thereto, substantially as and for the purpose specified.

2. In a vehicle dash sewing machine the combination with a throat plate having a side
35 recess a' therein, a needle guide projecting from said plate into said recess, a vertically operated presser bar and a presser foot b^2 carried thereon, said presser foot being inclined forwardly over said plate recess and
40 having a straight lip termination b^3 and an opening b^5 , of a feed dog d consisting of a shank portion d' and bifurcated forwardly inclined head portion e , the arms of the latter being adapted to project within the plate
45 recess a' and on opposite sides of the needle guide, substantially as and for the purpose specified.

CHARLES F. SCHWAB.

In presence of—

C. M. VOORHEES,
C. C. SHEPHERD.