



1

(椎間板)

EP - 0,356,112

가

가

가

가

/

가

가,

가

가

가

가

(fortiori)가

, 0.60 d 0.90 d , d  
 , , , , ,  
 , , , , ,  
 (traction) , , , , ,

가

가

가

(anti - shearing effect)가

가

0.35 d 0.65 d

d

h

0.45 h 0.85 h

1 , 1 ,

2 1 ,

3 1 ,

4 5 , 2 ,

6 7 4 .

1 2 , ( 2 ) (2) .

(4) (4) 가

(6) 가 , (8)

(10) , 가 (10)

(8) , 3 (10) ,

(12) (10) 가 (12)

(14) , (relief) (hydroxyapatite) (4)

(16) (18) (20) (16) (16)

0) (12) (22) (12) (12) (12) (12) (16) (1)

(22) (12) (18) (20)

(16) (8) (10) (4) ,

(12) 4 1 (22)

(4) (8) (20)

(10) (12) (16)

(16)가 (8) (10) (4) (12)

(6) (16) (6) (crest) (26) (convolution)

2 (h) 가 , d , h 0.75 d (10) , (12) , 0.60 d 0.90 d (6)

(10) 2 (20) (4) (12) (10), (r) 0.35 d 0.65 d 0.45 h 0.85 h 가 , r 0.66 h 0.5 d

(10) (12) (16) (12) (12) , (12) (10) (22) (12) (4) 가 (1

6) (16)가 가 , (22) (10)

3 (30) 가 (4) (30) (4) (14) (32) , (30) (indentation) (32) (bone screw, 34) (30)

(34) (4) (14) 가 (posterior hilum) (bean) 3

4 7 1 100 가 2

(102) , (104) (110) .  
 (110) (106) (112) 가 ,  
 (106)가 (110) (111)  
 (116) (106) (113)  
 (110) (112)  
 (111, 113) (112) ( )  
 (112)  
 가

(116) , 가 (118)  
 (116) (118) (122) ,  
 (118) (112) (116)  
 (122) (118) (122)  
 (112) (113) (122)  
 가

(116) (110) (104) 가 , (113)  
 (122) (110) (122) , 4 (113)  
 (111) (118)( )

22) (104) (106) (115) , (1  
 (115)가 (110)

, , , 4 , (110) (115)  
 (115) (110)  
 (115) (115)  
 (122) 가

(r, h, d) 가 , 3

, (110) 가 (112) 가  
 , (112) ,  
 가

가 (112)  
(104)

(10)

가, (116)

(110)

(116)가

가

(rigidity)

(116)

(104)

(112)

가

가

가

가

가

(112)

가

가

가

가

가

가

가

가  
가

1

2

가

(10)

(10, 110) (4, 104) ,

(4, 104) (10, 110) .

(16, 116) .

, , (12, 112) 가 .

(57)

1.

(4, 104) , (16, 116)  
(2, 102) ,

(4, 104) 가 (12, 112) 가  
(16, 116) 가 (10, 110)

2.

(4, 104) , (16, 116)  
(2, 102) ,

(4, 104) (16, 116) 가 (10, 110)

3.

1 2 ,  
(10, 110) (4, 104)

4.

1 3 ,  
(10, 110)

5.

1 4 ,  
(10, 110) 0.60 d 0.90 d (h) , d  
(4, 104)





13.

1 12 ,  
 (104) (110) , (115)

14.

1 13 ,  
 (4, 104) , (10, 110)

15.

1 14 ,  
 (4, 104) (12, 112) (10, 110) ,

16.

15 ,  
 (10, 110) 0.35 d 0.65 d (r) , d  
 (4, 104)

17.

15 16 ,  
 (12, 112) , (10, 110)가 0.45 h 0.85 h (r) , h

18.

1 17 ,  
 (12, 112) (4, 104) (10, 110) ,

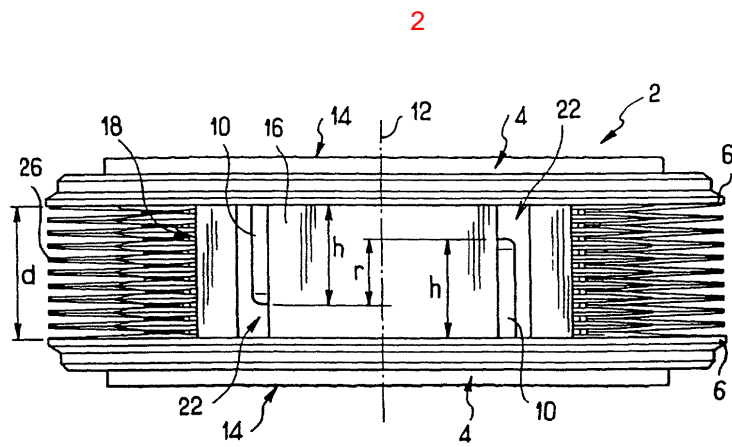
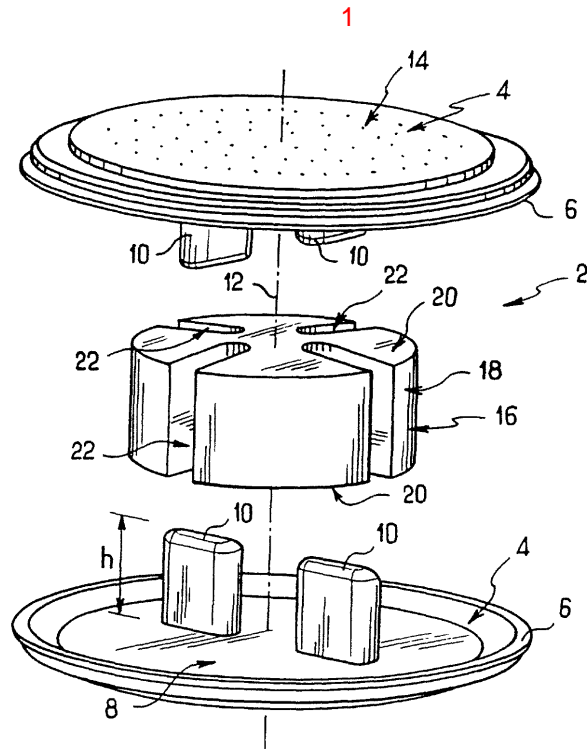

3

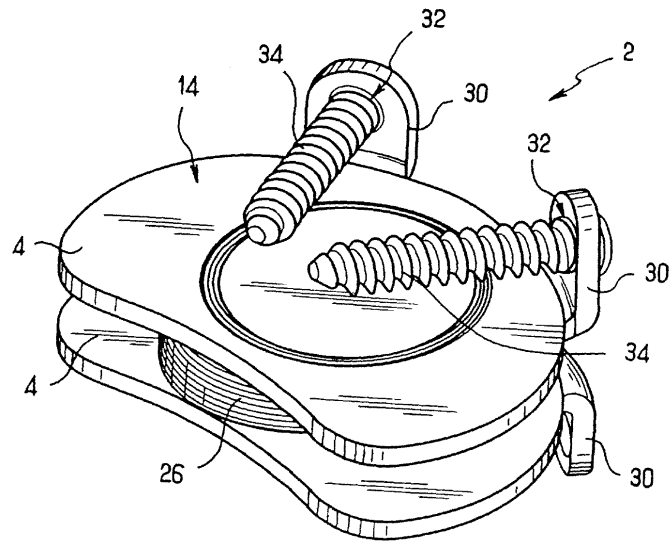

4

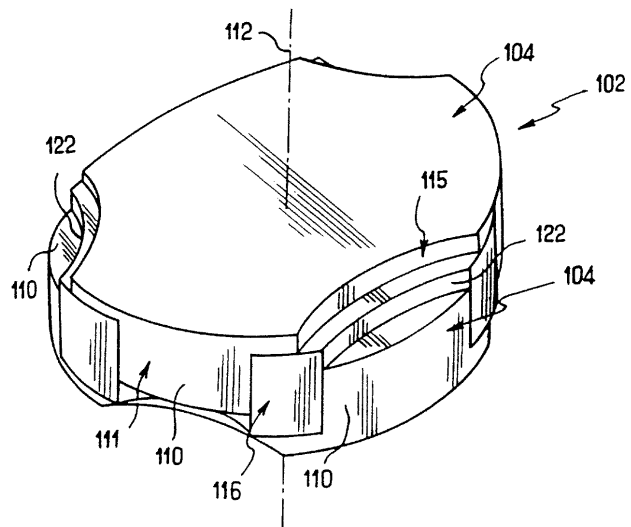

5

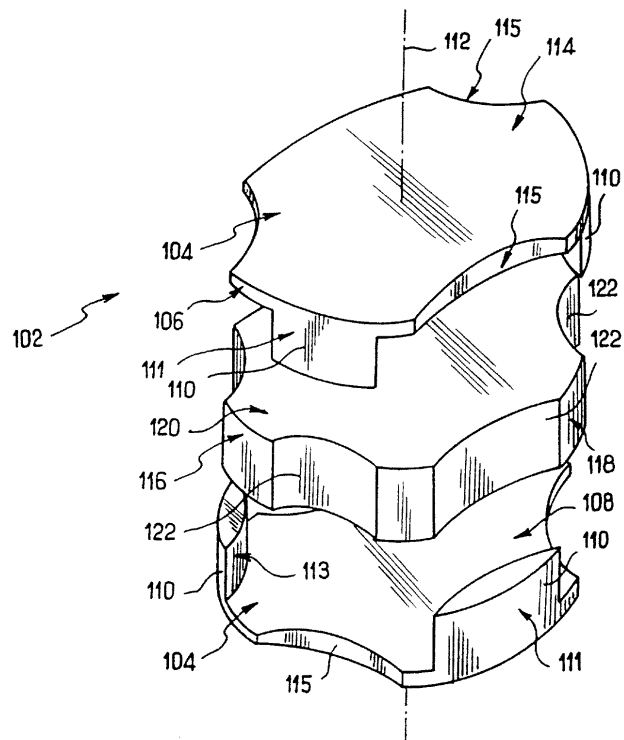

6

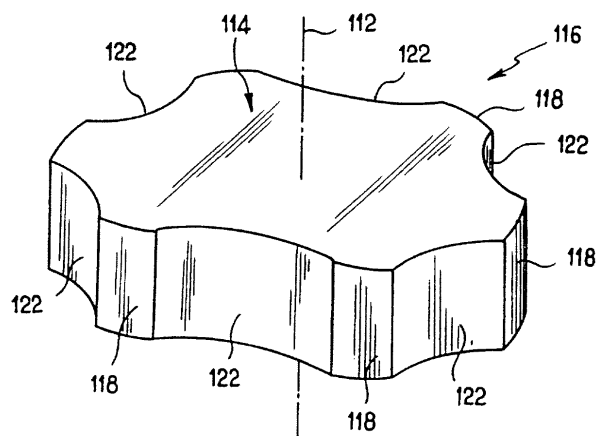

7

