



US00D544757S

(12) **United States Design Patent**  
**Jones et al.**

(10) **Patent No.:** **US D544,757 S**

(45) **Date of Patent:** **\*\* Jun. 19, 2007**

(54) **INSULATED CONTAINER**

(75) Inventors: **Andrew L. Jones**, Andover, KS (US);  
**Michael D. Brockel**, Wichita, KS (US);  
**Timothy M. Holub**, Cheney, KS (US);  
**Mitchell L. Wilgus**, Andover, KS (US)

(73) Assignee: **The Coleman Company, Inc.**, Wichita,  
KS (US)

(\*\*) Term: **14 Years**

(21) Appl. No.: **29/248,764**

(22) Filed: **Aug. 31, 2006**

(51) **LOC (8) Cl.** ..... **07-01**

(52) **U.S. Cl.** ..... **D7/605**

(58) **Field of Classification Search** ..... D7/605-608,  
D7/709, 710; 62/457.1-457.7, 239, 371,  
62/376, 3.62, 3.64; 220/592.16, 59.17, 592.2,  
220/592.23-592.27, 915.1, 915.2; 280/47.1,  
280/47.26, 47.37; D15/81; D12/423, 424;  
190/18 A

See application file for complete search history.

(56) **References Cited**

**U.S. PATENT DOCUMENTS**

4,724,681 A \* 2/1988 Bartholomew et al. .... 62/239  
5,319,937 A \* 6/1994 Fritsch et al. .... 62/3.62  
D357,354 S \* 4/1995 Marchwiak et al. .... D3/279  
D370,159 S \* 5/1996 Fenton et al. .... D7/605  
6,364,329 B1 \* 4/2002 Holub et al. .... 280/47.26

**OTHER PUBLICATIONS**

Coleman 2006 Outdoor Products Catalog, (pages related to coolers),  
2005, pp. 114-123, The Coleman Company, Inc., Wichita, Kansas.

\* cited by examiner

*Primary Examiner*—Terry A. Wallace

(74) *Attorney, Agent, or Firm*—Leydig, Voit & Mayer, Ltd.

(57) **CLAIM**

The ornamental design for an insulated container, as shown  
and described.

**DESCRIPTION**

FIG. 1 is a side perspective view of an embodiment of our  
new insulated container;

FIG. 2 is a front elevation view thereof;

FIG. 3 is a right side elevation view thereof;

FIG. 4 is a left side elevation view thereof;

FIG. 5 is a side perspective view of an alternate embodiment  
of our new insulated container;

FIG. 6 is a right side elevation view thereof;

FIG. 7 is a left side elevation view thereof;

FIG. 8 is a front elevation view thereof; and,

FIG. 9 is a rear elevation view thereof.

The broken line showing is for illustrative purposes only and  
forms no part of the claimed design.

**1 Claim, 4 Drawing Sheets**

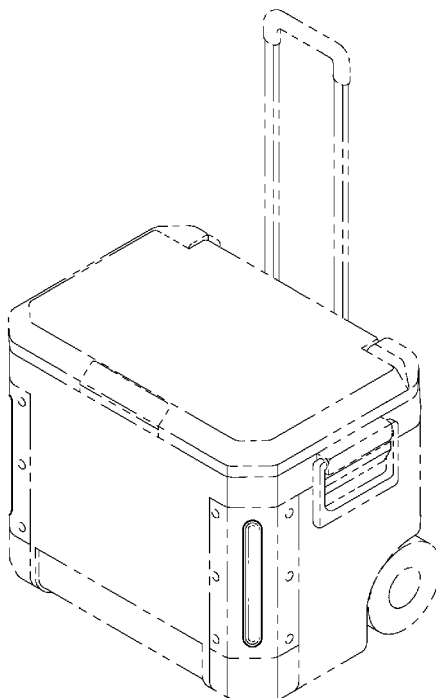

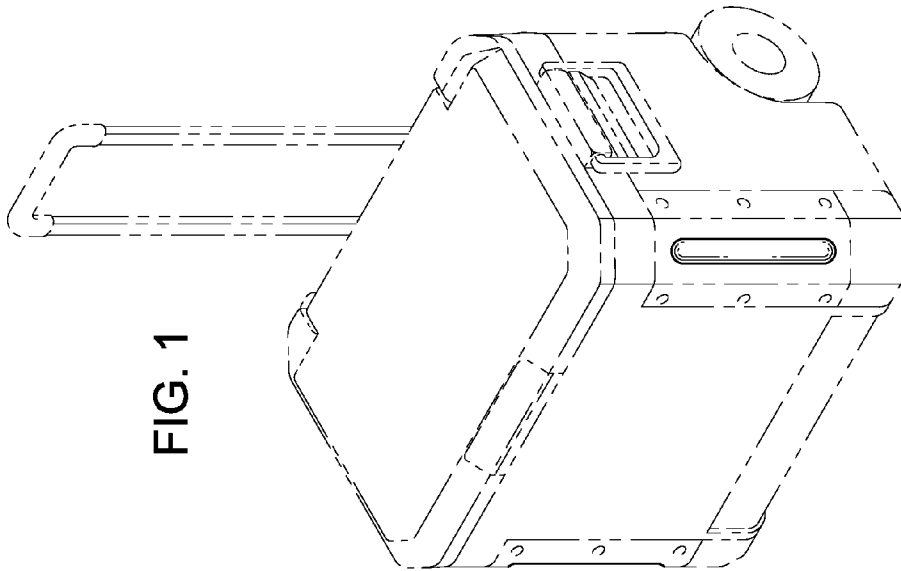
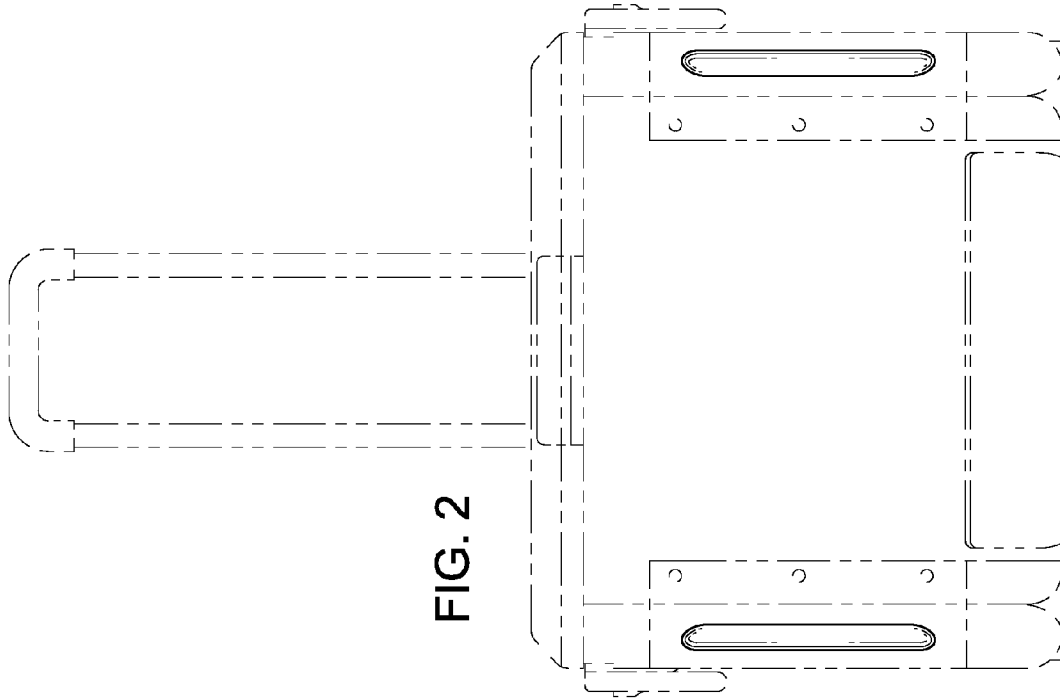

FIG. 4

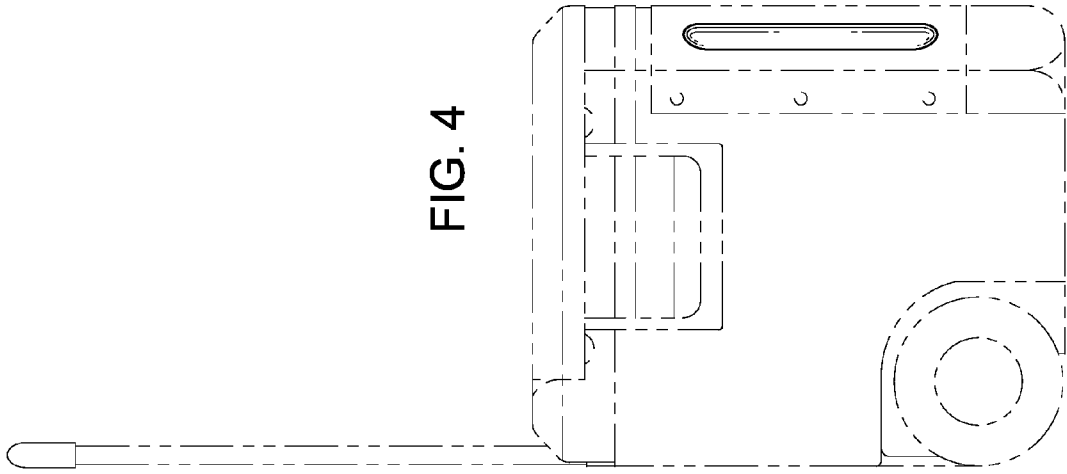
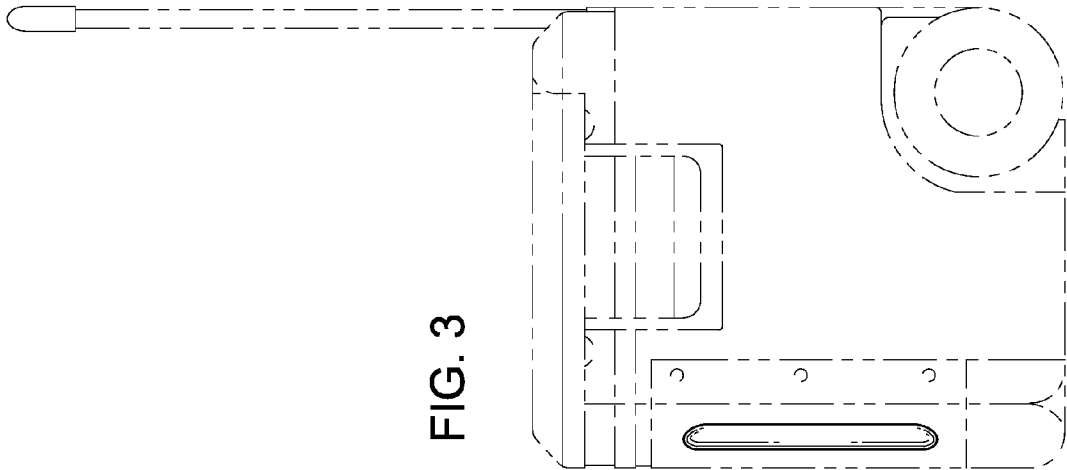

FIG. 3



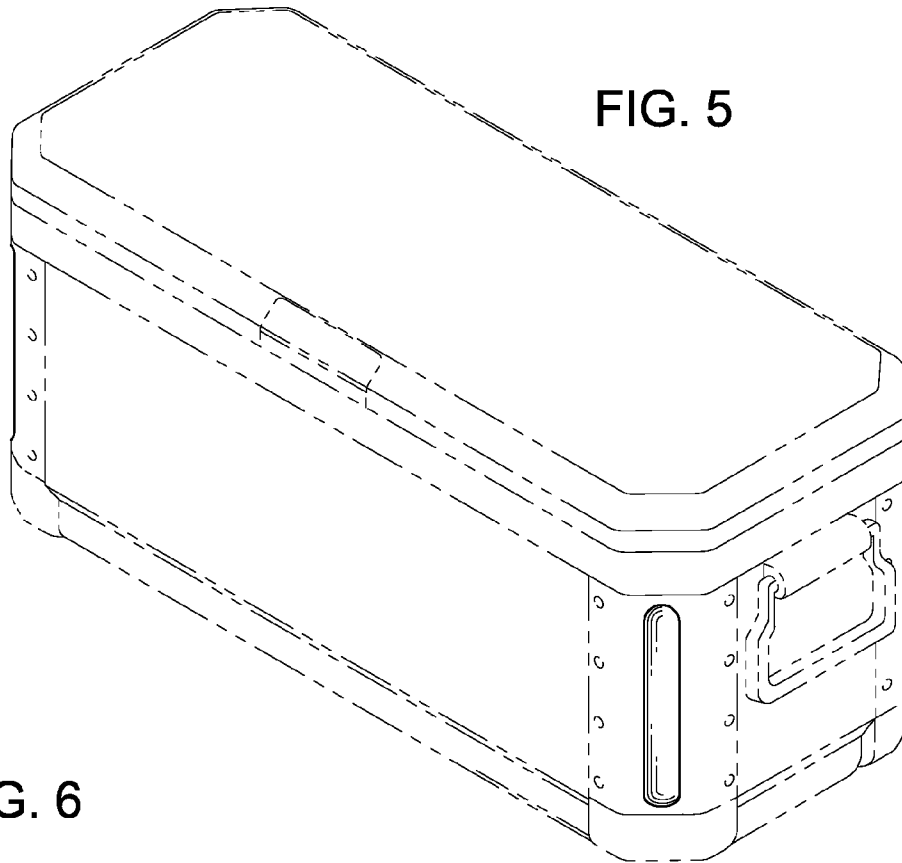

FIG. 6

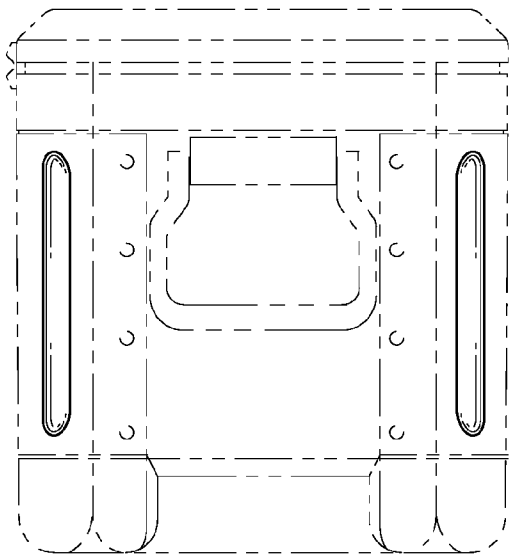
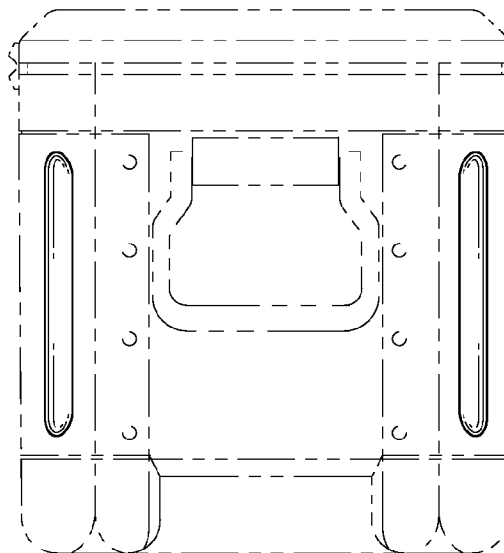

FIG. 7



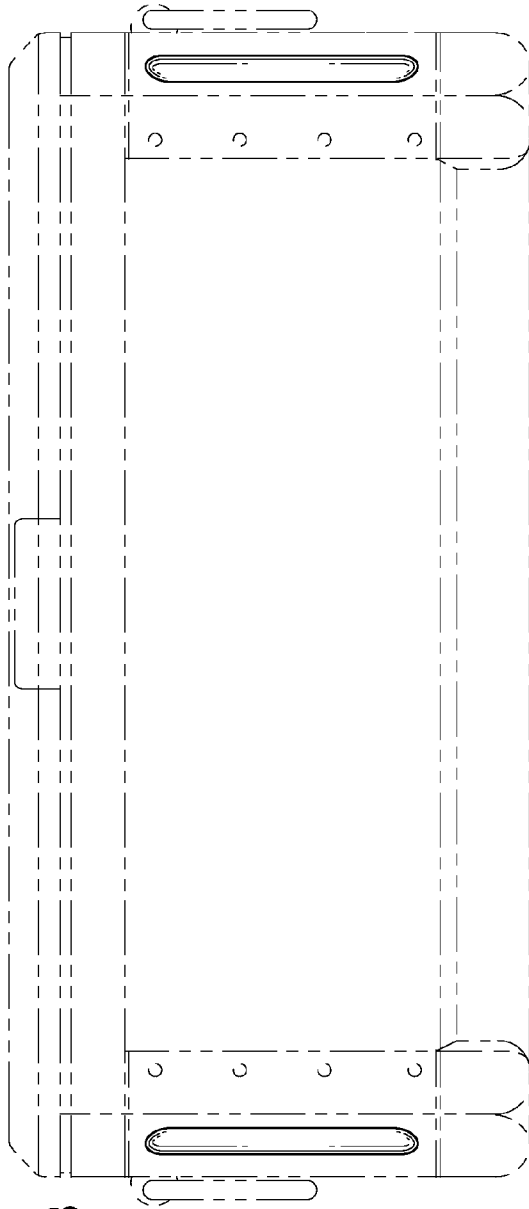

FIG. 8

FIG. 9

