

J. NAYLOR, Jr.  
Machine for Slicing Logs into Strips.

No. 219,296.

Patented Sept. 2, 1879.

*Fig. 1.*

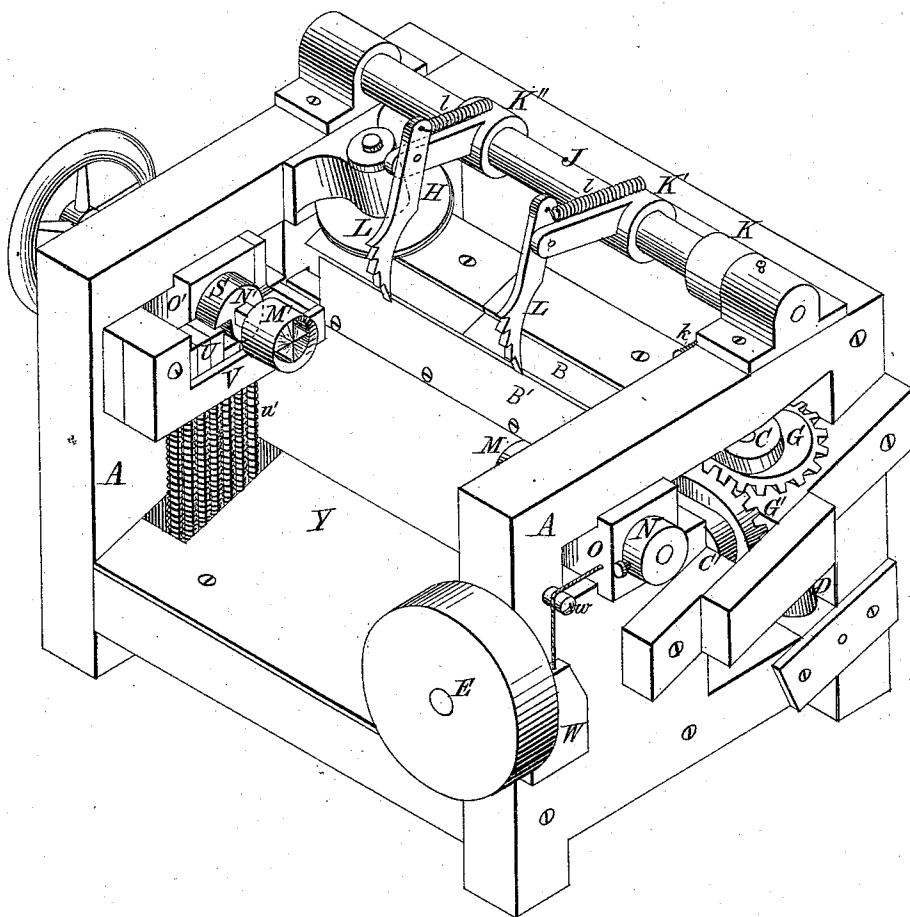

*Attest:*  
*H. H. Schott*  
*A. P. Cowl*

*Inventor:*  
*James Naylor Jr*  
*per J. C. Parker & Co attys*

J. NAYLOR, Jr.  
Machine for Slicing Logs into Strips.

No. 219,296.

Patented Sept. 2, 1879.

Fig. 3.

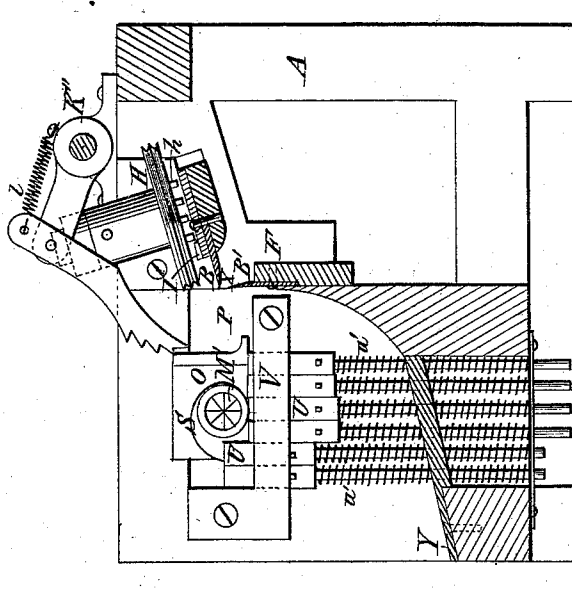
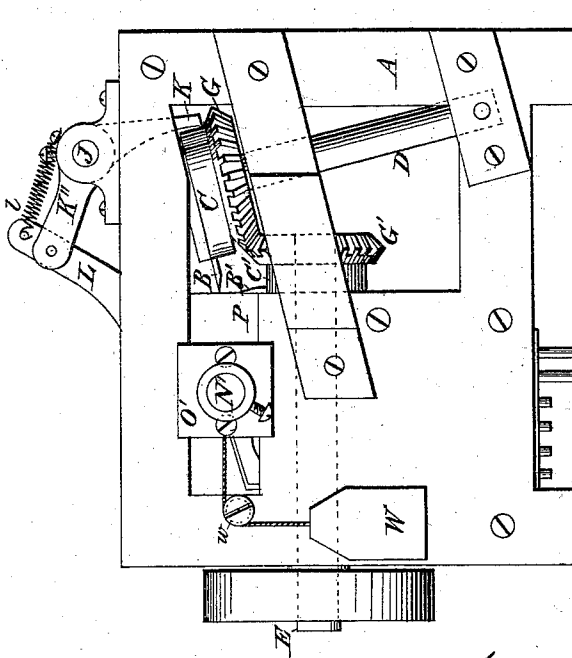

Fig. 2.



Attest:  
H. H. Schott,  
S. P. Cowl

Inventor:  
James Naylor Jr.  
Per J. C. Parker & Co.

J. NAYLOR, Jr.  
Machine for Slicing Logs into Strips.

No. 219,296.

Patented Sept. 2, 1879.  
*Fig. 4.*

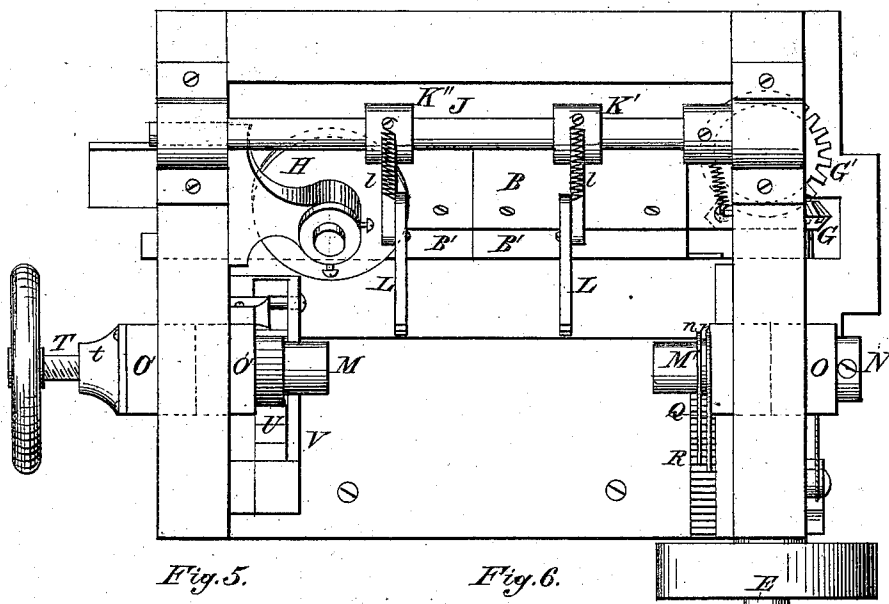

*Fig. 5.*

*Fig. 6.*

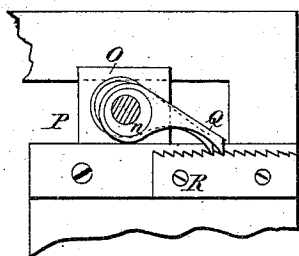
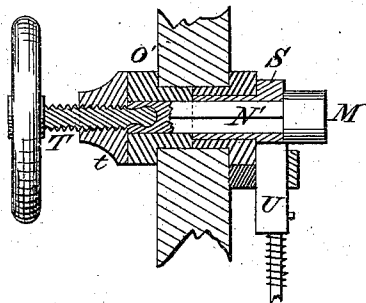

*Fig. 7.*

*Fig. 8.*

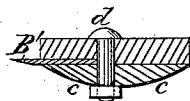
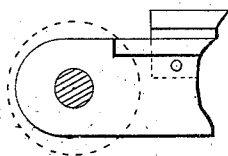

Attest:  
H. B. Schott.  
A. P. Cowl

Inventor  
James Naylor Jr.  
per H. B. Schott & Co.

# UNITED STATES PATENT OFFICE.

JAMES NAYLOR, JR., OF ROCHESTER, ASSIGNOR TO BURRELL, IVES & CO.  
AND D. H. BURRELL, OF LITTLE FALLS, NEW YORK.

## IMPROVEMENT IN MACHINES FOR SLICING LOGS INTO STRIPS.

Specification forming part of Letters Patent No. **219,296**, dated September 2, 1879; application filed January 27, 1879.

*To all whom it may concern:*

Be it known that I, JAMES NAYLOR, JR., of the city of Rochester, in the county of Monroe and State of New York, have invented certain new and useful Improvements in Machines for Cutting up Logs of Wood into Strips; and I do hereby declare that the following is a full, clear, and exact description of the invention, which will enable others skilled in the art to which it appertains to make and use the same, reference being had to the accompanying drawings, and to letters of reference marked thereon, which form a part of this specification.

Figure 1 is a perspective view of the machine complete; Fig. 2, an end view, showing the driving-shaft and gear. Fig. 3 shows a vertical cross-section. Fig. 4 is a plan. Figs. 5, 6, 7, and 8 are enlarged detailed views of different parts of the machine.

My invention relates to that class of machines in which a log is operated upon by moving cutters and cut into strips for various uses. It is simple and substantial in construction, and the improvements in the construction and various movements of the devices forming it over the machines now in use for similar purposes form the chief features of my invention, the object being to produce a machine so strong, simple, and inexpensive that it can be readily sold and not require skilled labor in operating it.

To enable others to understand fully my improvements, I will describe the operation of these machines as heretofore constructed.

The log is first chucked between centers and a feed applied to its periphery, which serves to rotate the log on the centers, and at the same time raise them as the log diminishes in size by the removal of strips from its periphery. The cutting is done by reciprocating knives working alternately and at right angles to each other. By these devices a log is cut up into strips of a given width and thickness.

Among the changes I make to overcome present objections are the simplification of working parts, thus reducing the great expense of the same, and a reduction in the great power required to operate the machines now used.

The parts A A constitute the frame-work of the machine, which is so designed that strength and facility of operation are obtained. Another feature in the construction of this frame-work is that the logs can be readily hoisted and swung into the machine; and still another important item in the design and construction of this frame-work is that a track can be laid and a car run on said track directly into the machine, so that the strips as cut may fall onto the car and be carried away.

B B' are reciprocating knives, working alternately or otherwise on the periphery of the log. One of these knives, B, cuts the width of strip, while the other, B', cuts the thickness. These knives B B' are set at an obtuse angle to each other, for the reason that the required strips are wanted with as square an edge as possible. When these knives are set at right angles to each other—that is, their face sides—it is evident that the exit for the strips cut is on an acute angle. Therefore it is impossible for them to leave the required square edge, and, moreover, great friction is caused in their exit from the cramped space between the backs of the knives.

By setting the face of knives B B' at a slightly obtuse angle, the exit of the strips at X is wider; hence the strips are cut and leave the machine with their edges even and rectangular. This new arrangement of the knives B B' has other beneficial results. The knife B', cutting the thickness of strip, cuts with the rotation of the log, as in other machines, and is operated by an eccentric, C', on the shaft E. As the stroke of this knife is small, the wear of the knife-edge is small in comparison with the wear of the other knife, B, cutting the width of the strip, or five times as much as the knife B'. Consequently there is a difference in the adjustment of these knives.

B' is attached to its bed in the ordinary way by screws; but the knife B is made of two or more sections, held to their bed by means of the straps *c c* and bolts *d d*. (See Fig. 8 in drawings.) By this arrangement a much thinner knife can be used, and it can be easily taken out and readjusted. Should the knife be broken, the whole length is not lost, the knife being in segments. It is also

easily handled in sharpening, which is a most important consideration.

The knife B is operated directly from the shaft D, there being no connecting-rods or other intermediate devices. The knife B' is also operated directly from the eccentric C' upon the shaft E. This knife passes through the ways or guides F in the frame, which hold and aid to keep it in its course. The knives B B' are driven in conjunction by means of the bevel-gears G G'.

Power is applied to either the shaft D or E, but preferably to the shaft E, thereby allowing the main driving-shaft to be under the floor of the room in which the machine is placed. By this simple arrangement a great amount of friction is avoided.

The peculiar stroke or cut of the knife is a great saving of power, as will be understood when it is remembered that one hundred and twenty-six square inches must be cut through to make a strip capable of forming an ordinary barrel-hoop, and when one hundred of such strips must be cut per minute the importance of this saving is plainly seen.

The knife-beds, having a pivotal movement at one end and operated at the other by the eccentrics, act as levers, and also have the drawing cut, which most effectually tends to prevent checking of the strips.

The feed movement, or the means used to rotate the log as the knives operate on it, is as follows: When a log is chucked in the machine it may have a very uneven surface. For these uneven logs a feed must be had for the purpose of truing the log, and again, when the log is trued up, a feed must continue which is perfectly positive in its operation, as the feed gives the thickness of strip to be cut. It is also essential that these feeding devices be so constructed as to work in unison or independent of each other. If the logs are trued up in another machine preparatory to being chucked in this machine, then one feed is sufficient and is preferred; but if the rough logs are to be chucked, then it is needful to make use of both devices.

H is the screw or worm, which, as the log is forced up to it, bites into its periphery. On the under side of this screw or worm is arranged, at equal distances, four tappets or studs, *h*. On the strap which holds the knife B is a projection, I. This projection, having the movement of the knife-bed, describes an ellipse, and on its return, after the knife has done its cutting, this projection acts on one of the tappets *h* and carries the screw or worm H one-quarter round, another stroke forces it another quarter, and so on. The pitch or lead of screw H must be equal to the thickness of four strips.

The screw is made of cast-steel, and when the sharp thread is embedded in the periphery of the log it does not lose its hold, but forms a positive feed, which is utilized as soon as the log is trued up.

J is a rock-shaft extending across the top

of the frame. On this shaft, at the end where the throw of the knife-bed is greatest, is secured the arm K, with its lower end extending down, so as to be acted on by the knife-bed in its movement. A spiral spring, *k*, is so arranged as to bring back the arm to its original position after being acted on by the knife-bed. Thus is given to the rock-shaft J an intermittent oscillating motion.

K' K'' are arms secured to this rock-shaft, to the ends of which are attached the pawls L L, the lower sharp teeth of which bite into the periphery of the log, and on their return are kept in position for work by the spiral springs *l l*.

It will be observed that the pawls L L have a varied movement, which adapts them to take hold of any surface, no matter how uneven it may be. It must also be borne in mind that, however effectual this device may be in truing the log, it could never be depended upon where continued accurate work is called for; hence its combination with the screw positive feed.

By these feeding devices the roughest logs are cut up evenly, which is a great convenience, for the reason that these strips so cut are frequently operated on by other machines, and by having them of a uniform thickness these machines work to better advantage.

The log is fed to the two reciprocating knives. M M' are the centers between which the log is chucked. These centers are so constructed that when they engage in the log they must invariably rotate with it; hence the mechanism to feed the log to the knives must be operated from these centers, which are secured to and form an extension of the shafts N N', having their bearing in the sliding boxes O O', said boxes having a free movement horizontally in the spaces P.

On the shaft N are the double eccentrics *n n*, by which are actuated the pawls Q, which engage in the rack R, secured to the framework. Rotation of the log and center M turns the eccentrics, which works the pawls Q Q. They, alternately engaging in the rack, force the box O forward, carrying the center M and the log.

The throw of the eccentrics, or one revolution of center M, is equal to the width of strip cut.

The center M' is secured to the shaft N', which passes through the cam S. This cam has its bearing in the box O', the shaft N' having its bearing within the cam S. The shaft N' extends through the box O, and attached to it, on the outside of the frame, is the screw T, provided with a hand-wheel. This screw T is so attached to the shaft N' as to be free from its rotation. The screw runs through the nut *t*, affixed to the box O'. This arrangement is for chucking the log by means of the hand-wheel, which revolves the screw, forcing the center inward, the end of the screw acting as a stationary step for the shaft N' to turn on.

U U are packing-blocks, having the long downward extension through the spiral springs

*w*' and the lower guides. These packing-blocks have a free up-and-down movement, and are kept in place by the strap V. The spiral springs *w*' serve to keep the packing-blocks up, and at the same time allow them to be pressed down when desired.

When the box O' is back, as it is when a log is chucked, and the operation of cutting strips commences, the cam S is rotated, its surface bearing against the packing-blocks, and causing the box O', with the center M' and the log, to be forced forward. When the full side of the cam S is just about to quit the packing-block, the next packing-block is automatically raised by its spring to serve the purpose of the preceding one, and so on until the log is all cut up.

It may be observed that the two devices shown for keeping the log to the knife can be used in combination or separate—that is, to use the same device on both ends. It is the quality and style of the strips cut which call for these different devices.

An arrangement is attached to the boxes O O' to cause their automatic return to position after the core of the log cut has been released from between the centers. In this arrangement, W is a weight attached to a cable passing over the roller *w*, and attached to the boxes O O'. When the boxes are at the end of the space P, after the log is cut, the weights W are drawn up, and as soon as released gravitation brings the centers back into position for the chucking of another log.

Another improvement is the inclined bed Y underneath the log. This is for the purpose of rolling out the core of the log when released from between the centers.

Having thus specified the various improvements in my machine, I proceed to describe the operation.

A log is gripped by the tackle-hooks, hoisted by a crane, and swung into the machine between the centers, the hand-wheel is rotated, and the centers forced into the ends of the log, where it is securely held. Meanwhile the machine is constantly running, no stoppage being necessary; as the log is stationary. The next thing is to rotate the log, which is done by hand. The rotation of the log, of course, turns the centers, which operates the cam S on the packing-blocks U and the eccentrics *n n* and pawls Q Q on the rack R. Thus the boxes O O' are forced along the spaces P, and carry along with them the log, which first comes in contact with feeding-pawls LL, which, with their teeth, act on its surface, no matter how rough it may be. After this feed begins to take hold of the log the machine is started. At first the lumps or unevenness of the log is cut off, and about the same time that good strips begin to come off the screw feed-wheel H is acting on the surface of the log. This feed is positive, and insures the strips of even thickness. It also presents a broad bearing-surface against the push of the vertical knife. A car for the reception of strips has previously

been run into the rear of the machine, and the strips fall directly onto it as soon as cut. When the log is so reduced that only the core remains all that has to be done is to release the core by turning the hand-wheel. The core falls onto the inclined bed Y and rolls clear of the machine. On the release of the retaining devices the boxes O O', carrying the centers M M', are drawn back automatically by the weights W, and are in position to receive another log.

Having thus described my invention, I wish it to be understood that I do not claim reciprocating knives acting on the surface of a log, neither a feed-movement applied to the periphery of the same; but I do claim the improved means employed whereby these objects are obtained.

I claim—

1. The knife B, made in sections, having a continuous straight edge, and attached to a solid backing or knife-bar, substantially as herein described, and having a sliding pivotal movement at one end, with a circular motion at the other, in combination with the crank-shaft D, the crank of which is directly connected with the knife-carrier, as and for the purpose specified.

2. The cutting-knife B', having a comparatively small movement for cutting the edge of the strip, in combination with the knife B, having a greater scope of motion to cut its width, both knives having a sliding pivotal motion at one end and a circular motion at the other, and their operating-shafts and gear, arranged substantially as specified.

3. The combination of the cutting-knives, their driving-gear, and the shafts D E, the knives and shafts being set at an obtuse angle to each other for the purpose of reducing friction and giving a free exit to the cut strip, as set forth.

4. The feeding-screw H and its operating devices, constructed substantially as shown and described, and operating upon the surface of the log to feed it forward in the manner stated.

5. The toothed pawls L, acting upon the outer surface of the log, as described, in combination with their operating mechanism, consisting of the rock-shaft J, its arms, and the crank G upon the shaft D, all arranged substantially as stated.

6. The screw feed-wheel H, operated by the knife B, as described, in combination with the pawls L and their actuating mechanism, for the purpose of feeding the logs, as set forth.

7. The moving center M, provided with the eccentrics *n*, in combination with the pawls Q and rack R, for the purpose of moving the log to the cutters, as specified.

8. The feeding devices, consisting of the vertically-moving spring-supported blocks U, in combination with the rotating center-chuck and cam S, substantially as shown and described.

9. The feeding devices hereinbefore de-

scribed, consisting of the worm H and pawl k, for rotating the logs upon their axis, in combination with the mechanism for giving a forward movement to the same while being cut into strips, as described.

10. The sectional knives B, having a continuous straight edge, attached to their carrier by the convex holding-plates *c* and bolts *d*, in the manner shown and described, to allow of their ready removal and reattachment, for the purpose stated.

11. The horizontally-moving boxes O and O', in combination with the weights W and their connecting-cables, for the purpose of automatically retracting the boxes, as set forth.

12. The frame having inclined bed Y, the retracting centers, and vertically-cutting knives, all arranged as shown and described, for the purpose of facilitating the introduction of logs and removal of cores, as set forth.

In testimony that I claim the foregoing as my own I affix my signature in presence of two witnesses.

JAMES NAYLOR, JR.

Witnesses:

C. VAN VECHTEN,  
WATTS. T. LOOMIS.