



US00D940129S

(12) **United States Design Patent**  
**Lin**

(10) **Patent No.:** **US D940,129 S**  
(45) **Date of Patent:** **\*\* Jan. 4, 2022**

(54) **NETWORK STORAGE DEVICE**

FOREIGN PATENT DOCUMENTS

(71) Applicant: **Quanta Computer Inc.**, Taoyuan (TW)

CN 300491738.0000 \* 5/2008  
CN 305595988 \* 2/2020  
CN 305633460 \* 3/2020

(72) Inventor: **Shih-Cheng Lin**, Taoyuan (TW)

(73) Assignee: **QUANTA COMPUTER INC.**,  
Taoyuan (TW)

OTHER PUBLICATIONS

(\*\*) Term: **15 Years**

H665GR GPON Gigabit Ont, Dasan, lancentrum.eu, author unlisted, published on Aug. 20, 2018 per wayback machine © DASAN Network Solutions, Inc., online, site visited Mar. 19, 2021. Available from Internet, URL: [http://www.lancentrum.eu/download/tovar/1532680714\\_H662GR\\_DataSheet\\_EN\\_V1.0\\_170531.pdf](http://www.lancentrum.eu/download/tovar/1532680714_H662GR_DataSheet_EN_V1.0_170531.pdf) (Year: 2018).\*

(21) Appl. No.: **29/710,091**

(22) Filed: **Oct. 21, 2019**

*Primary Examiner* — Holly E Thurman  
*Assistant Examiner* — Altaira J Swangin  
(74) *Attorney, Agent, or Firm* — McClure, Qualey & Rodack, LLP

(30) **Foreign Application Priority Data**

Jun. 20, 2019 (TW) ..... 108303629

(51) **LOC (13) CL.** ..... **14-02**

(52) **U.S. CL.**  
USPC ..... **D14/348**

(58) **Field of Classification Search**  
USPC ..... D14/167, 172, 204, 300–301, 314, 348,  
D14/355–358, 363, 365–367, 433–437,  
D14/480–480.1, 480.7, 484.1; D13/103,  
D13/168–169, 171, 107–108, 110;  
D18/11–12

CPC ..... H01L 23/4093; H05K 5/03; H05K 5/04  
See application file for complete search history.

(57) **CLAIM**

The ornamental design for a network storage device, as shown and described.

**DESCRIPTION**

FIG. 1 is a front top right perspective view of a network storage device, showing my new design; FIG. 2 is a front view thereof; FIG. 3 is a rear view thereof; FIG. 4 is a left side view thereof; FIG. 5 is a right side view thereof; FIG. 6 is a top plan view thereof; FIG. 7 is a bottom plan view thereof; FIG. 8 is a rear, left and bottom perspective view thereof; FIG. 9 is a partial enlarged view of the area '9' designated by the dash-dot region in FIG. 2; and, FIG. 10 is a partial enlarged view of the area '10' designated by the dash-dot region in FIG. 3.

The even-dash broken lines in the drawings represent portions of the network storage device and form no part of the

(56) **References Cited**

U.S. PATENT DOCUMENTS

D260,881 S \* 9/1981 McKinsey ..... D14/435  
D307,293 S \* 4/1990 Sawada ..... D18/11  
D347,210 S \* 5/1994 Sharpe ..... D13/164  
D383,736 S \* 9/1997 Corrington ..... D14/367  
D387,333 S \* 12/1997 Pellow ..... D13/162  
D400,206 S \* 10/1998 Mahgerefteh ..... D14/188  
D400,497 S \* 11/1998 Sabag ..... D13/103

(Continued)

(Continued)

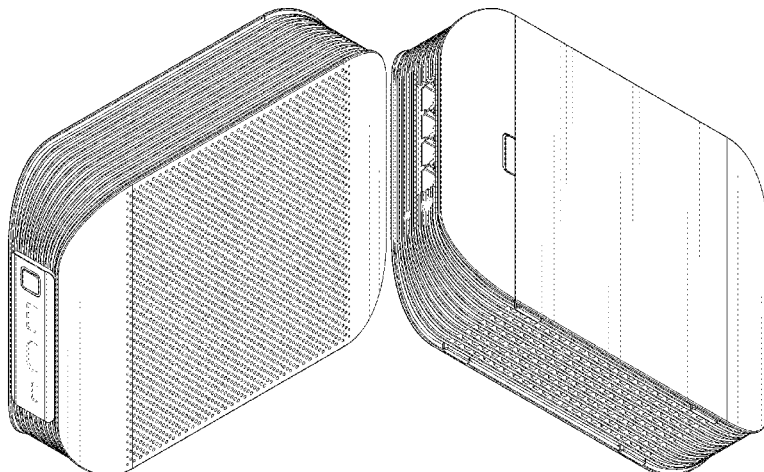

claimed design, and the dash-dot broken lines in FIGS. 2-3 and 9-10 represent the bounds of the enlarged detail views and form no part thereof.

**1 Claim, 9 Drawing Sheets**

(56)

**References Cited**

U.S. PATENT DOCUMENTS

D456,403 S \* 4/2002 Witte ..... D14/355  
 D462,940 S \* 9/2002 Castagna ..... D13/162  
 D494,952 S \* 8/2004 Taniguchi ..... D14/140.1  
 D520,012 S \* 5/2006 Nishio ..... D13/147  
 D520,996 S \* 5/2006 Deng ..... D14/480.5  
 D530,323 S \* 10/2006 Hsu ..... D14/348  
 D534,909 S \* 1/2007 Weiher ..... D14/356  
 D585,439 S \* 1/2009 Ching ..... D14/300  
 D593,082 S \* 5/2009 Jeon ..... D14/240  
 D613,727 S \* 4/2010 Xie ..... D14/240  
 D619,570 S \* 7/2010 Tong ..... D14/240  
 D623,125 S \* 9/2010 Kawabata ..... D13/103  
 D632,643 S \* 2/2011 Tanaka ..... D13/103  
 D632,650 S \* 2/2011 Rashid ..... D13/110  
 D644,221 S \* 8/2011 Kemery ..... D14/358  
 D648,726 S \* 11/2011 Behar ..... D14/435.1  
 D654,856 S \* 2/2012 Inskeep ..... D13/107

D669,060 S \* 10/2012 Huang ..... D14/240  
 D675,196 S \* 1/2013 Maddern ..... D14/240  
 D678,327 S \* 3/2013 Lee ..... D14/496  
 D719,939 S \* 12/2014 Liang ..... D14/240  
 D729,216 S \* 5/2015 Peng ..... D14/240  
 D737,819 S \* 9/2015 Tsai ..... D14/365  
 D752,013 S \* 3/2016 Benedetti ..... D14/204  
 D757,678 S \* 5/2016 Kelly ..... D14/204  
 D757,820 S \* 5/2016 Leopardi ..... D14/496  
 D764,957 S \* 8/2016 Bhattacharya ..... D10/104.1  
 D778,280 S \* 2/2017 Vanderpol ..... D14/363  
 D778,889 S \* 2/2017 Nagao ..... D14/240  
 D783,583 S \* 4/2017 Moon ..... D14/240  
 D784,922 S \* 4/2017 Liden ..... D13/107  
 D789,930 S \* 6/2017 Webb ..... D14/348  
 D790,539 S \* 6/2017 Lee ..... D14/358  
 D826,145 S \* 8/2018 Kim ..... D13/103  
 D826,146 S \* 8/2018 Kim ..... D13/103  
 D826,147 S \* 8/2018 Kim ..... D13/103  
 D826,148 S \* 8/2018 Kim ..... D13/103  
 D826,847 S \* 8/2018 Kim ..... D13/103  
 D848,867 S \* 5/2019 Matsumiya ..... D10/49  
 D851,033 S \* 6/2019 Yuk ..... D13/108  
 D878,288 S \* 3/2020 Choi ..... D13/103  
 D886,049 S \* 6/2020 Lee ..... D13/107  
 D888,660 S \* 6/2020 Jen ..... D13/108  
 D890,698 S \* 7/2020 Liu ..... D13/108  
 D898,668 S \* 10/2020 Jang ..... D13/108

\* cited by examiner

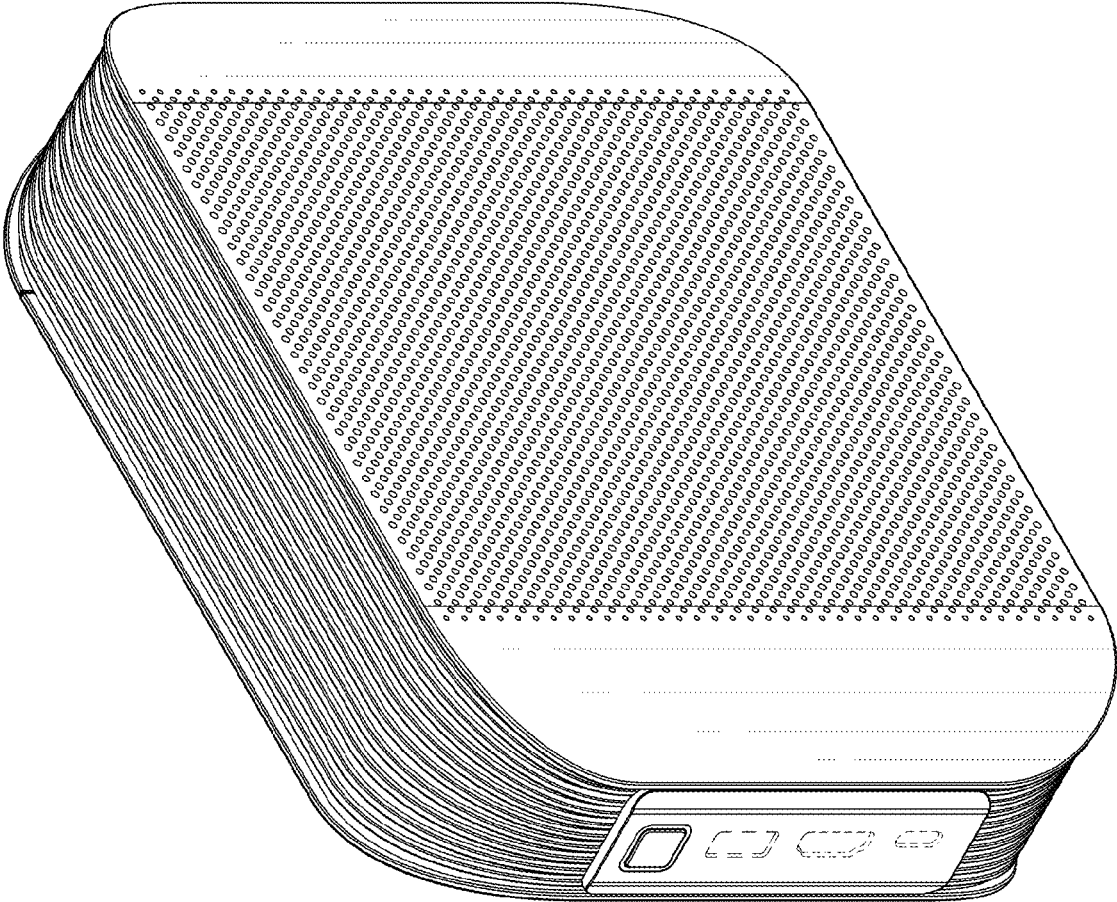

FIG. 1

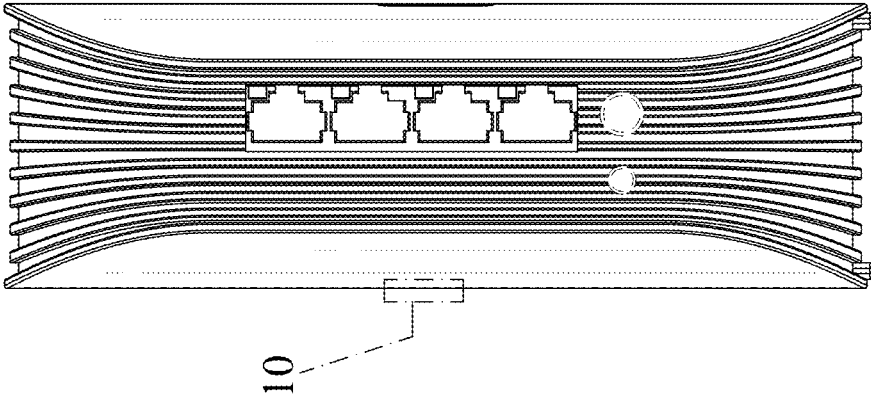

FIG. 3

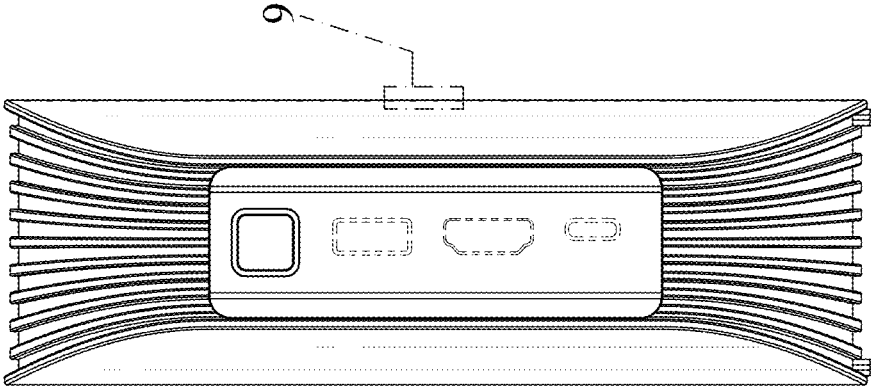

FIG. 2

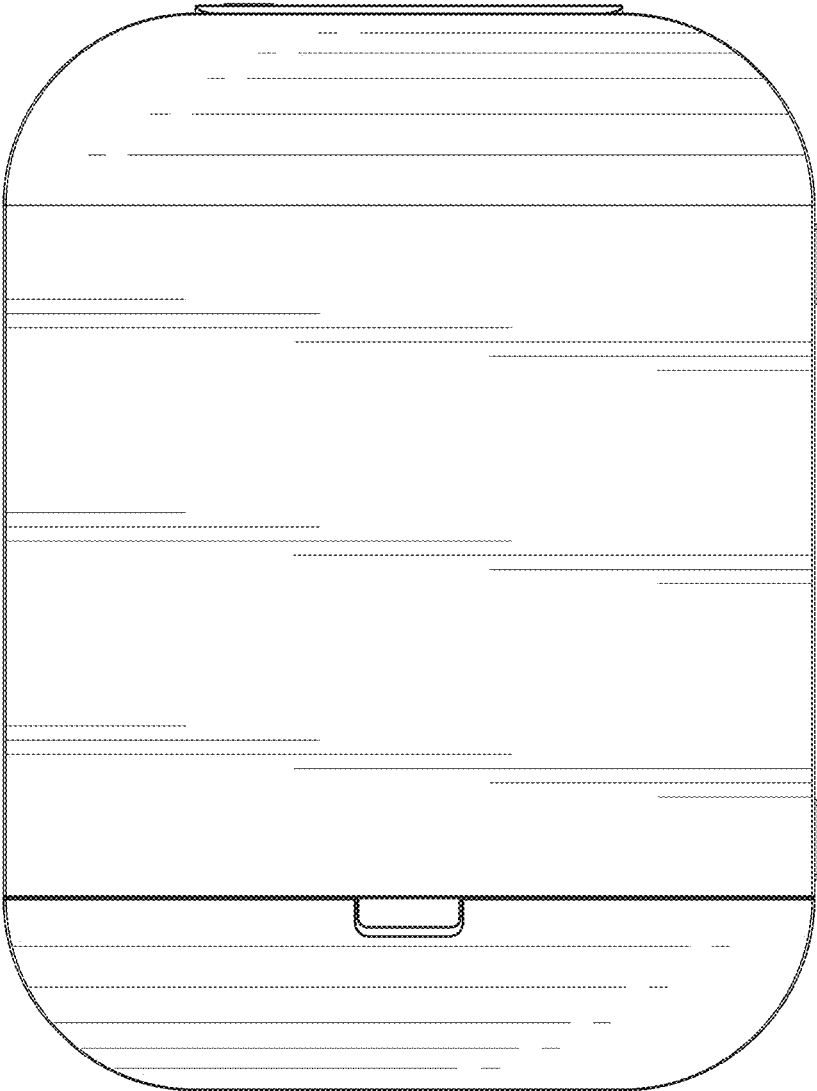

FIG. 4

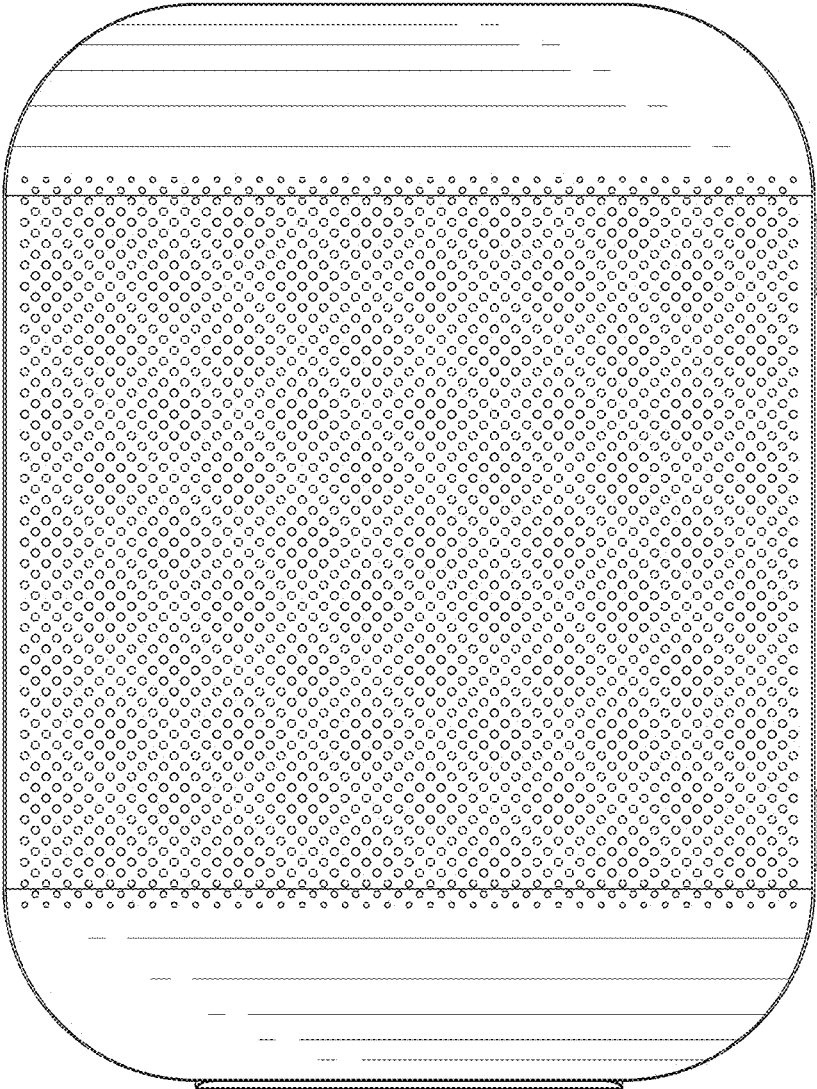

FIG. 5

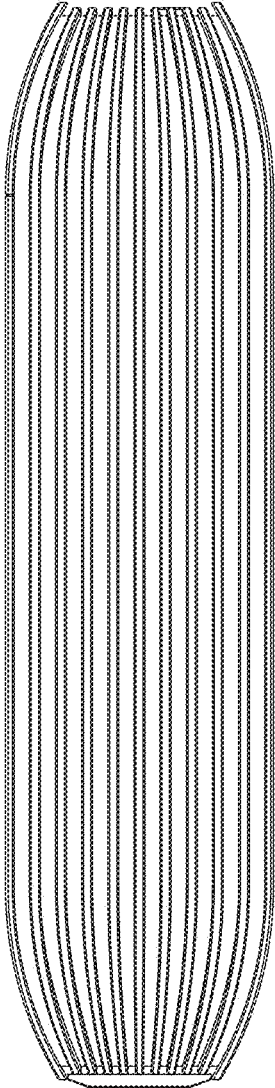

FIG. 6

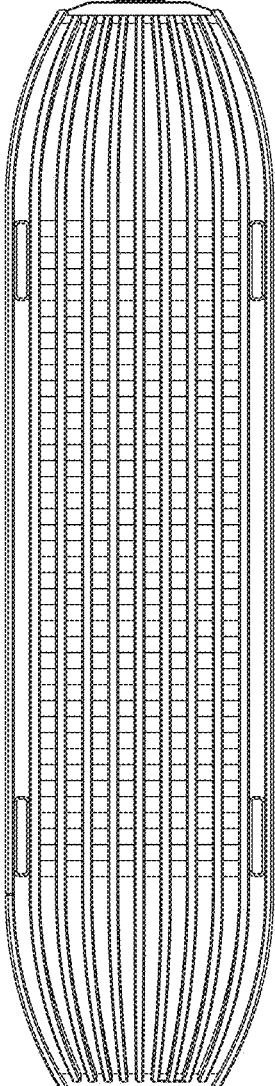

FIG. 7



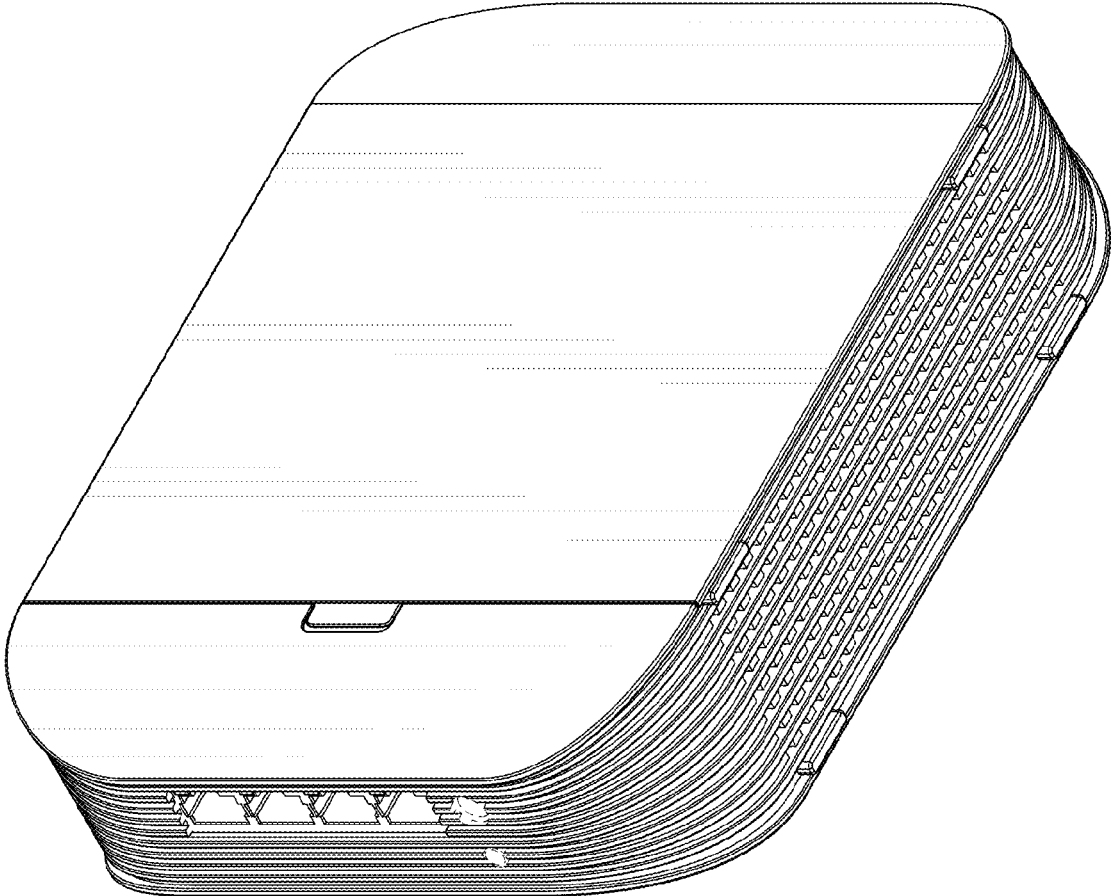

FIG. 8

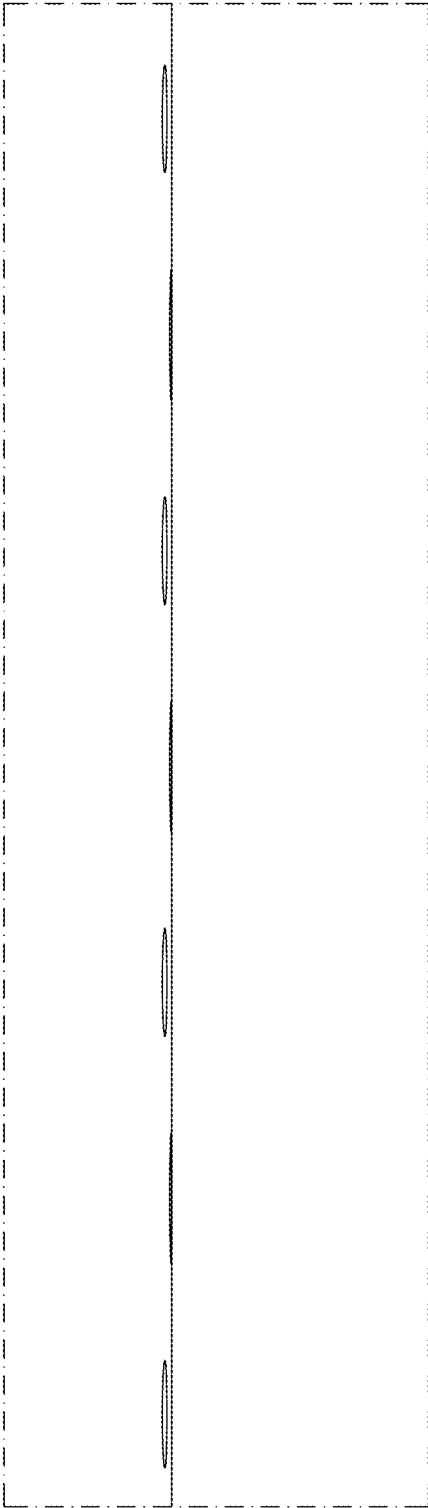

FIG. 9

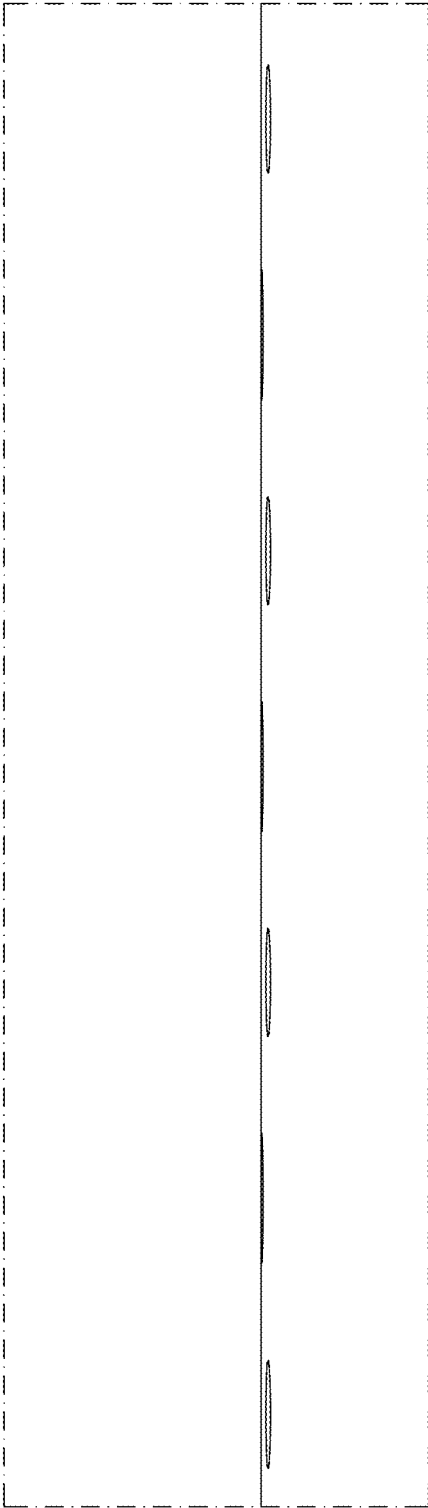

FIG. 10