

(No Model.)

F. H. RANSOM & A. W. SANGSTER.

BRACE HINGE FOR TRUNKS.

No. 316,399.

Patented Apr. 21, 1885.

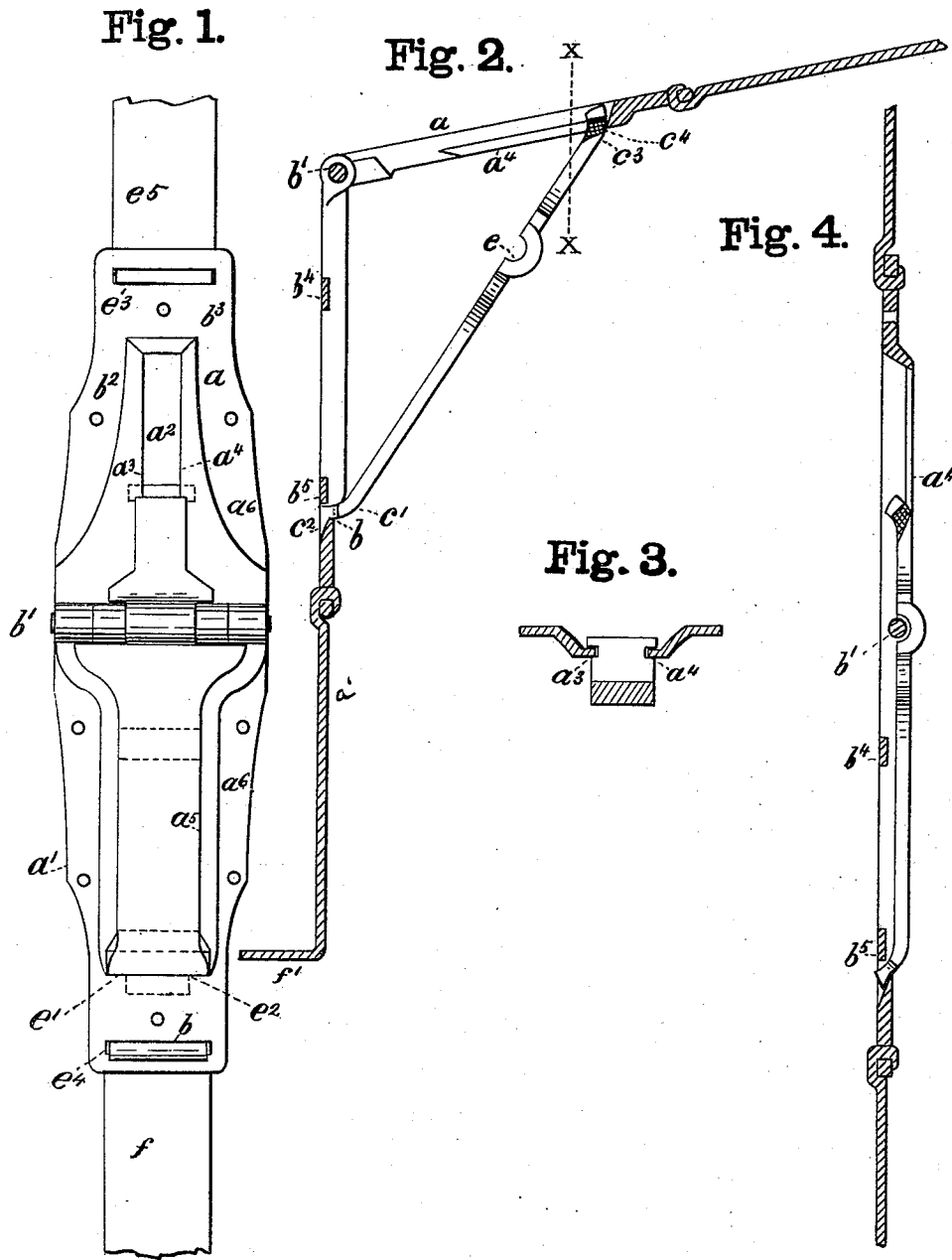

Witnesses.

Nellie Gordon.
Jennie W. Caldwell.

Inventors.

Frank H. Ransom.
Amos W. Sangster.
By James Sangster
Att.

UNITED STATES PATENT OFFICE.

FRANK H. RANSOM AND AMOS W. SANGSTER, OF BUFFALO, NEW YORK;
SAID SANGSTER ASSIGNOR TO SAID RANSOM.

BRACE-HINGE FOR TRUNKS.

SPECIFICATION forming part of Letters Patent No. 316,399, dated April 21, 1885.

Application filed July 14, 1884. (No model.)

To all whom it may concern:

Be it known that we, FRANK H. RANSOM and AMOS W. SANGSTER, citizens of the United States, residing at Buffalo, in the county of Erie and State of New York, have invented certain new and useful Improvements in Brace-Hinges, of which the following is a specification.

Our invention relates to certain improvements in brace-hinges; and its object is to provide a strong and durable hinge combined with a brace for holding the cover of a trunk at the proper angle or position when opened, and to give additional strength to the trunk, all of which will be fully and clearly hereinafter shown by reference to the accompanying drawings, in which—

Figure 1 is a face or front view of the hinge complete. Fig. 2 is a sectional elevation showing the position of the parts when attached to a trunk and the cover opened. Fig. 3 is a cross-section through a portion of the hinge in line xx , Fig. 2. Fig. 4 is a sectional elevation of the hinge, showing an edge or side view of the same when opened or in the position it would be if on a trunk and the cover closed.

In the said drawings, a represents the upper half or leaf of the hinge, and a' the lower half. In the upper portion, a , is a slot or opening, a^2 , having the slideways $a^3 a^4$. There is also an opening through the leaf and a ridge, a^5 , nearly surrounding it, leaving the thin portion, a^6 . b represents a small cross-opening in the lower portion of the part a' .

The two parts or leaves $a a'$ are joined together by a pin, b' , in the usual way, the pin passing through both from side to side, as shown. The upper part of the hinge is also provided with a raised portion or ridge, b^2 , around the opening a^2 , leaving the thin portion b^3 .

$b^4 b^5$ represent thin cross pieces or braces, which act as strengthening-pieces.

The brace c is provided at its lower end with a curved portion, c' , having a slight enlargement, c^2 , at the end. Its upper end is also provided with a curved end, c^3 , and grooves $c^4 c^5$ on each side of the end, which grooves

are adapted to fit the slideways $a^3 a^4$. The openings through the leaves are of the same shape as the brace, so that when the hinge is in the position shown in Fig. 4 the brace shuts down close, leaving a smooth surface, with nothing projecting to catch against.

The brace is also provided with a groove, e , which shuts over the pin b' when it is closed.

In putting the hinge together the brace is placed at right angles, or nearly so, to the plate or leaf a' , and the end $c' c^2$ is inserted into the cross-opening b , the shoulders $e' e^2$ on each side preventing it from going in too far. The opposite end is inserted so as to fit the slideways by turning it to one side, putting it in place, and then turning it in its proper position again, after which the pin b' is inserted, thereby securing the hinge and all the parts together, the ends of the brace being so formed that it cannot be taken out without taking the hinge apart. The upper and lower ends of the hinge are each provided with a slot or opening, $e^3 e^4$. Into these openings are hooked, as shown, or otherwise secured thereto, straps of metal or other suitable material, e^5 and f , as an additional security and strength to the trunk; they may be either short straps, or be made long enough to go around the trunk by having bent corner portions, f' . These straps, as well as the hinges, are secured to the trunk by screws or rivets, or in any other well-known way.

We claim as our invention—

A hinge for trunks, consisting of the parts $a a'$, each having secured thereto an angular strap, e^5 and f , in combination with a brace having a curved end, c' , and a slight enlargement, c^2 , adapting it after being put in place and the hinge secured together to act as a joint and provided with a groove, e , to shut over the pin b' when closed, so that the brace may fit down in the groove and thereby leave a smooth surface, substantially as described.

FRANK H. RANSOM.
AMOS W. SANGSTER.

Witnesses:

JENNIE M. CALDWELL,
A. J. SANGSTER.