

May 26, 1931.

G. PISTOR

1,807,090

CHARGING MEANS FOR ELECTRIC FURNACES

Filed May 17, 1928

3 Sheets-Sheet 1

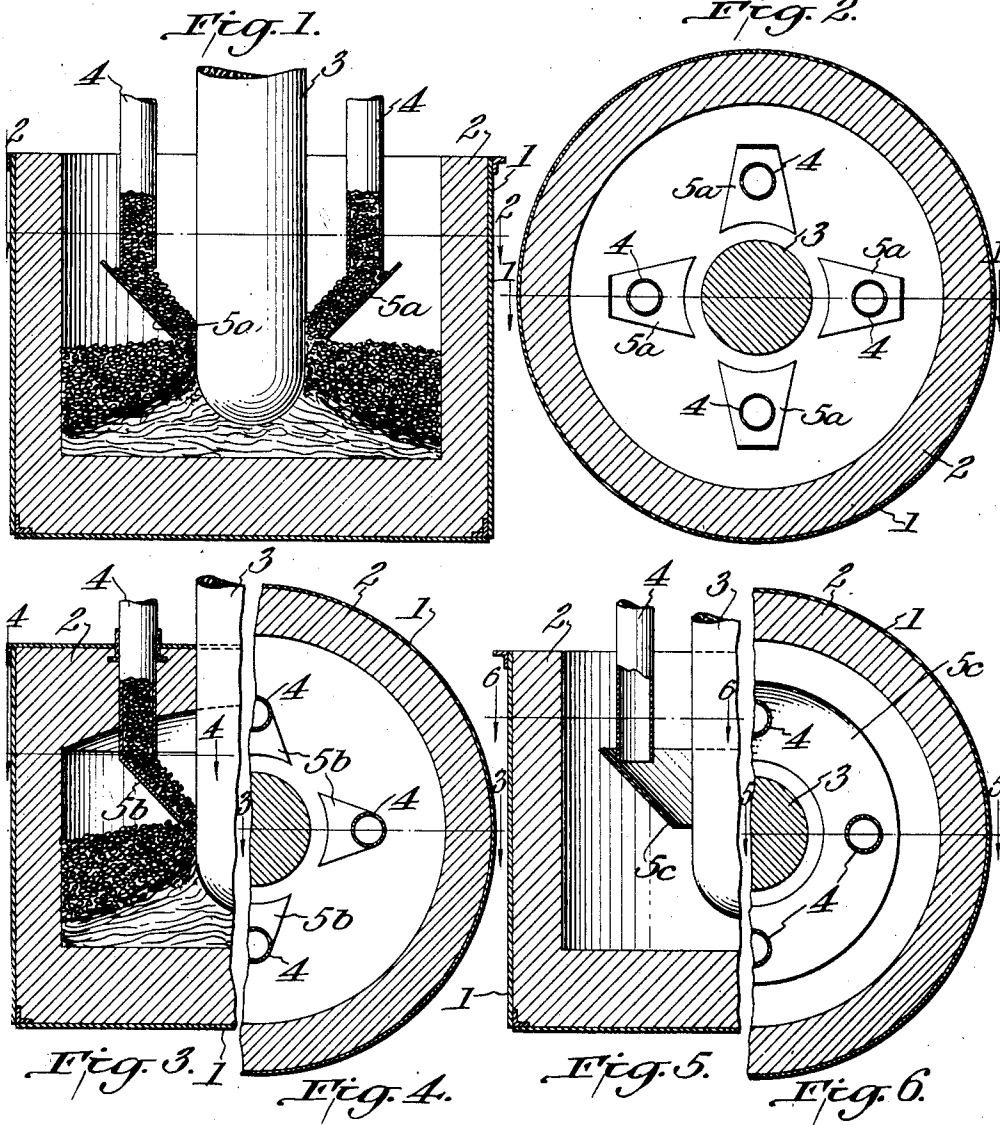

Inventor:

Gustav Pistor

By *Byrnes Townsend & Bruckenstein*

his Attorneys

May 26, 1931.

G. PISTOR

1,807,090

CHARGING MEANS FOR ELECTRIC FURNACES

Filed May 17, 1928

3 Sheets-Sheet 2

Fig. 7.

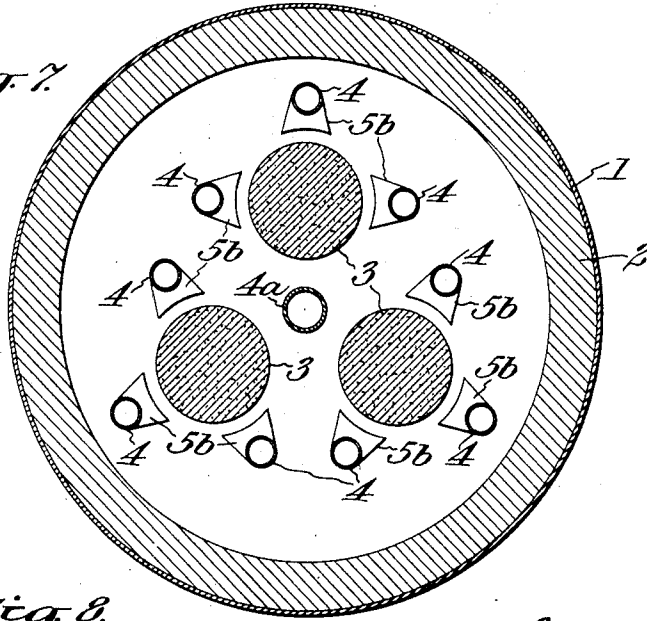

Fig. 8.

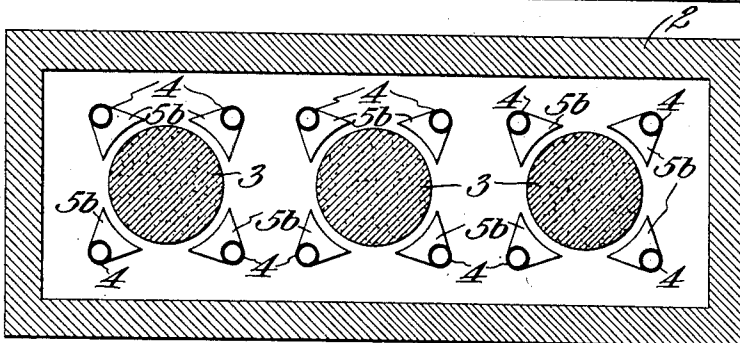
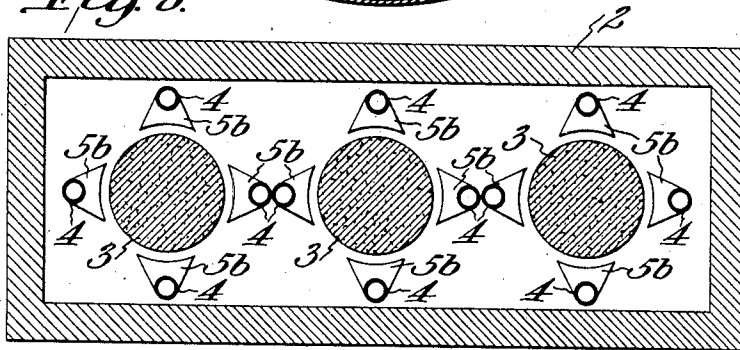

Fig. 9.

Inventor:

Gustav Pistor

By Byrnes Townsend & Brickman

his Attorney

May 26, 1931.

G. PISTOR

1,807,090

CHARGING MEANS FOR ELECTRIC FURNACES

Filed May 17, 1928

3 Sheets-Sheet 3

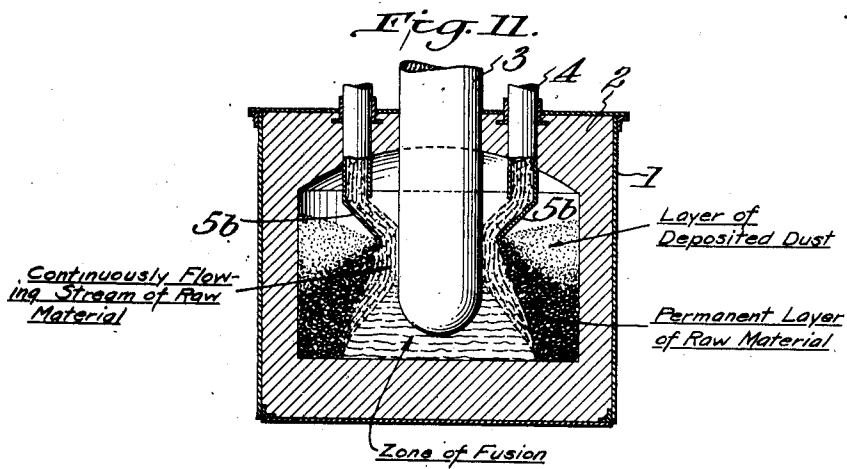
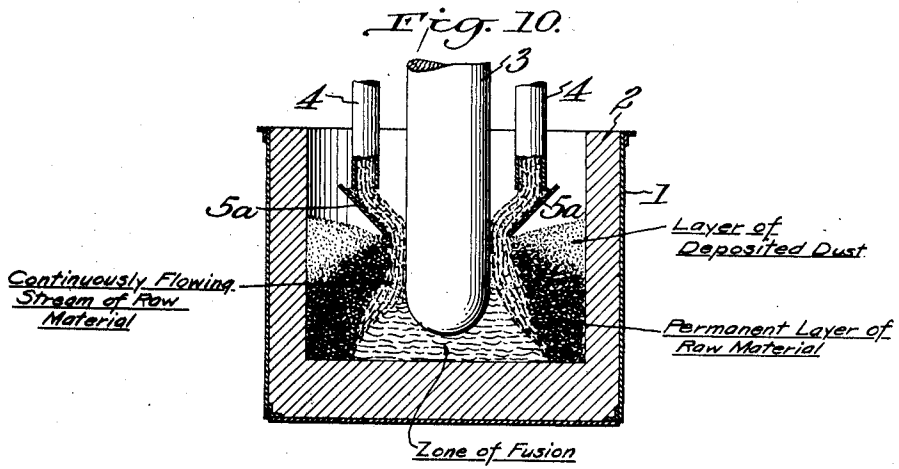

Inventor:
Gustav Pistor

By Byrnes Townsend & Bruckenstein

Attorneys

UNITED STATES PATENT OFFICE

GUSTAV PISTOR, OF LEIPZIG, GERMANY, ASSIGNOR TO I. G. FARBENINDUSTRIE AKTIENGESELLSCHAFT, OF FRANKFORT-ON-THE-MAIN, GERMANY, A CORPORATION OF GERMANY

CHARGING MEANS FOR ELECTRIC FURNACES

Application filed May 17, 1928, Serial No. 278,463, and in Germany May 18, 1927.

This invention relates to a method of charging electrical furnaces and to apparatus for carrying out said method.

The charging material for electrical furnaces usually consists of mixtures of raw materials of various kinds and of varying granular size and specific gravity, such as, for example, coke and lime in carbide furnaces; coke, raw phosphates and silica (and if necessary aluminium compounds) in phosphorus furnaces. It is only in the rarest cases that the ideal condition is realized, namely, that the size of the pieces or grains of the individual parts of the charge is so uniform that no segregation occurs in charging or in the heap formed on charging in the furnace. Reducing the pieces to uniform size is generally attended with too much expense, and owing to the different specific gravities of the constituents of the mixture, does not prevent segregation. Segregation, however, is of considerable disadvantage since it leads to very troublesome irregularities in the operation of the furnace, such as variations in the conductivity of the charge at various points, local displacements of the path taken by the current, short circuits, damage to the lining, impaired energy yield, and irregular removal of gas.

It has now been found that in spite of very considerable differences in the size of the pieces or the specific gravity of the constituents of the mixture, it is possible, by employing the method of charging hereinafter described with reference to the accompanying diagrammatic drawings to attain uniform distribution of a composite mixture of raw materials in an electric furnace, i. e., a distribution which is not liable to segregation.

In the drawings, Fig. 1, is a sectional elevation of one embodiment of the invention; Fig. 2 is a sectional plan on the line 2—2 of Fig. 1;

Figs. 3 and 4 are a partial sectional elevation and a partial sectional plan, respectively, of another embodiment of the invention;

Figs. 5 and 6 are a partial sectional elevation and a partial sectional plan, respectively, of a third embodiment of the invention; and

Figs. 7, 8 and 9 illustrate alternative modifications of the invention as applied to three-phase electric furnaces.

In the figures, which are more or less schematic representations of electric furnaces, 1 represents the shell of the furnace, 2 represents the wall or lining, 3 are electrodes, 4 and 4a are pipes for charging raw materials, 5a, 5b and 5c are distributing guides which will be more fully described hereinafter.

Figs. 10 and 11 show in a rather diagrammatic form the continuous flow of the charge within an open and within a closed furnace and the persistent conditions resulting therefrom.

According to the invention a definite path leading to the electrode is prescribed by means of guides for the material of the charge which is introduced in a continuous stream and any other movement of the same which may lead to segregation or other action is prevented. The guides employed consist of distributors 5a, 5b and 5c, which are arranged in the furnace at a definite, and if desired adjustable, height and inclination, in such a manner that they conduct the charge (which may be shovelled in by hand or introduced from bunkers through pipes 4) to the electrode or electrodes 3, by virtue of their inclined position. The pipes 4 may open direct into the distributing surfaces 5 (as in Figs. 3 and 4), or they may be kept separate therefrom (as in Figs. 1 and 2). These distributing surfaces may be made of cooled or uncooled sheet metal, refractory brick or other suitable material.

The shape of the distributing surfaces 5a, 5b and 5c is solely determined in accordance with the attainment of their purpose. When the charging pipe is in direct connection therewith, the triangular form 5b appears to be most suitable for the distributing vanes, the charge being admitted to one apex of the triangle from which it runs down in a continuous stream, at a rate corresponding to its consumption in the furnace, to the opposite lower side (facing the electrodes). In order to prevent premature lateral overflow, the distributing vane can be made concave or provided with a rim.

Preferably every electrode is surrounded according to its diameter by several of such distributing vanes. If several electrodes are disposed sufficiently close together to be served, for example, by one charging pipe, surrounded by the three electrodes of a three-phase alternating current furnace (Fig. 7), the distributing vanes may be allotted to a common pipe, or inasmuch as, owing to the limited space, segregation cannot very well occur between three electrodes, the arrangement of a central distributing vane can be dispensed with in this case, so that only the outwardly directed sides of the electrodes receive the charge of material through distributing vanes.

Where a free outlet is provided for the material from the charging pipe, the distributing vanes 5a may be approximately rectangular. The individual vanes may also consist (in case of one electrode) of a closed truncated cone (5c, Fig. 6), or, when there are three electrodes, these may be triangularly disposed in relation to three partially open truncated cones interconnected at the points of intersection.

Owing to the broadening of the current of material and to the check sustained at the electrodes, the manner in which the charge is distributed onto the vanes causes a uniform reduction in the speed of the individual parts and lessens the tendency to segregation during the consumption of the mixture in the furnace. Thus, for example, it prevents the coarser constituents from rolling away quicker than the finer constituents, and the latter from remaining at the electrode, as usually occurs in the case of a free slope as, for example, the known annular method of distribution at the electrode.

In the method of charging of this invention, materials, the constituents of which vary to an extraordinary degree in point of grain size, can be employed without danger of segregation. The distance between the electrode and the feeding edge of the distributing vane and the height and inclination of the latter can be adjusted according to working requirements.

In this method of charging, all the constituents of the mixture are bound to reach the electrodes in the prescribed relative proportions and must fall down thereon at the rate at which they melt away at the lower end of the electrodes. For example, prior to starting, the furnace may be charged uniformly to the desired height, and such portions of the charge as are situated outside the range of action of the electrode will remain substantially unconsumed, the supply of new material remaining restricted to the reaction zone. (Fig. 10 and 11.) By this means, not only is the melting or reaction zone concentrated in a definite and invariable area, where the full action of the heating current can occur, but

also the uniformity of the throughput of material is assured. At the same time, uniform discharge of the reaction gases is secured, these flowing in counter-current to the cold charging mixture which descends directly along the electrodes, and preheating said mixture. The result of this heat exchange is that the gases generated during the reaction escape at a temperature of only a few hundred degrees centigrade, while the mean temperature of the charge in the furnace, outside the reaction zone, is increased to such a slight extent that cooling the distributing vanes can generally be dispensed with.

The new method of distribution is of special importance for closed electrical furnaces (Figs. 3 and 4), where, owing to its uniform action, it can be developed into a purely mechanical charging method which is not liable to any disturbances resulting from the operation of the furnace.

The mixture of raw material in this case is placed, for example, in elevated bunkers outside the furnace, and is passed from these to the electrodes through the cover of the furnace in closed pipes which are automatically kept full and which open into the distributing vanes at the required points.

Moreover, the hereindescribed method is not restricted to the use of the aforesaid mixtures of crushed or comminuted raw material, but homogeneous (for example, briquetted) charging stock can be fed in the same way. Similarly, even with other than round electrodes (for example, sheaves of block electrodes), the new method of charging can be employed if the distributing surfaces be modified accordingly. The field of application of the method is also not restricted to the use of circular furnaces; Figs. 8 and 9 showing embodiments for rectangular furnaces. It is essential in all cases that the charge should be admitted direct to the zone around the electrode as being the zone of consumption.

It has already been proposed to feed the charge to the electrodes into closed vertical furnaces from closed bunkers by leading the material at intervals over chutes to the electrode and causing it to drop down along the latter. However, this method of charging lacks the characteristic feature of passing the charging stock in a continuous stream which is automatically regulated, from the bunker, over the distributing surfaces to the electrode, and along the latter, as far as the furnace hearth, in uninterrupted connection and corresponding to the rate of consumption.

The effect obtained by the present invention cannot be obtained in the known processes because, after leaving the sliding surfaces, the material drops freely onto the heap and thereby undergoes segregation.

Exhaustive researches have shown that it

is only by the complete avoidance of any free movement of the constituents of the charge that the result attained by the present invention can be attained.

I claim:

5 1. An electrical furnace comprising, in combination, an electrode extending into the lower part of the furnace, means for passing the charge towards the electrode, said means
10 comprising at least one distributing surface slantingly protruding towards and into close proximity of the lower part of the electrode, so as to allow the charge after having passed over the distributing surface to descend into
15 the reaction zone in contact with the electrode through the gap, thus formed, and means for withholding the charge from the upper part of the electrode, said means being placed within the furnace at a moderate distance
20 above said distributing surface.

2. An electrical furnace comprising, in combination, an electrode extending into the lower part of the furnace, at least one substantially plane-shaped distributing surface
25 slantingly protruding towards and into close proximity of the lower part of the electrode, so as to allow the charge after having passed over the distributing surface to descend into the reaction zone in contact with the electrode through the gap, thus formed, and at
30 least one pipe-like conduit for the charge descending into the furnace, at least part of the circumference of the lower aperture of said conduit being arranged at a moderate distance
35 above said distributing surface.

3. An electrical furnace comprising, in combination, an electrode extending into the lower part of the furnace, at least one shovel-shaped distributing surface slantingly protruding towards and into close proximity of
40 the lower part of the electrode, so as to allow the charge after having passed over the distributing surface to descend into the reaction zone in contact with the electrode through the gap, thus formed, and at least one pipe-like conduit for the charge descending into the furnace, at least part of the circumference of the lower aperture of said conduit being arranged at a moderate distance
45 above said distributing surface.
50

In testimony whereof, I affix my signature.

GUSTAV PISTOR.

55

60

65