

(12) INTERNATIONAL APPLICATION PUBLISHED UNDER THE PATENT COOPERATION TREATY (PCT)

(19) World Intellectual Property Organization  
International Bureau



(43) International Publication Date  
15 February 2001 (15.02.2001)

PCT

(10) International Publication Number  
**WO 01/11409 A2**

- 
- (51) International Patent Classification<sup>7</sup>: G02B 23/24 LAMPORT, Ronald, B.; 4 Benoit Avenue, Pelham, NH 03076 (US). KELLY, David, L.; 31 Brookside Road, Westford, MA 01886 (US).
- (21) International Application Number: PCT/US00/40599
- (22) International Filing Date: 8 August 2000 (08.08.2000) (74) Agent: REES, Dianne, M.; Testa, Hurwitz & Thibault, LLP, High Street Tower, 125 High Street, Boston, MA 02110 (US).
- (25) Filing Language: English
- (26) Publication Language: English (81) Designated States (*national*): DE, GB, JP.
- (30) Priority Data: 09/370,756 9 August 1999 (09.08.1999) US (84) Designated States (*regional*): European patent (AT, BE, CH, CY, DE, DK, ES, FI, FR, GB, GR, IE, IT, LU, MC, NL, PT, SE).
- (71) Applicant: LIGHTLAB IMAGING, LLC. [US/US]; 133 Littleton Road, Westford, MA 01886 (US). Published:  
— Without international search report and to be republished upon receipt of that report.
- (72) Inventors: SWANSON, Eric; 13R Oakwood Road, Ac-  
ton, MA 01720 (US). PETERSEN, Christopher, L.; 120  
Evergreen Lane, Carlisle, MA 01741 (US). McNAMARA,  
Edward; 67 High Street, Chelmsford, MA 01824 (US).  
For two-letter codes and other abbreviations, refer to the "Guidance Notes on Codes and Abbreviations" appearing at the beginning of each regular issue of the PCT Gazette.



**WO 01/11409 A2**

---

(54) Title: ULTRA-SMALL OPTICAL PROBES, IMAGING OPTICS, AND METHODS FOR USING SAME

(57) Abstract: Ultra-small optical probes comprising a single-mode optical fiber and a lens which has substantially the same diameter as the optical fiber. The optical fiber and lens are positioned in a probe housing which is in the form of an insertional medical device such as a guidewire. Connector elements are provided to facilitate the attachment of the probe to an optical system and the quick disconnection of the probe from the optical system. The probe is used to obtain optical measurements *in situ* in the body of an organism and can be used to guide interventional procedures by a surgeon.

## Ultra-Small Optical Probes, Imaging Optics, and Methods For Using Same

### FIELD OF THE INVENTION

The present invention relates to the design and manufacture of ultra-small optical probes and methods of using the same. More particularly, the invention relates to the use of such probes in optical beam delivery and optical imaging techniques, such as Optical Coherence Tomography (OCT).

### BACKGROUND OF THE INVENTION

5 Medical diagnostic techniques which rely on measuring the optical properties of a narrow, twisting lumen (e.g., small arteries and veins) or a small space (e.g., pulmonary airways) require ultra-small optical probes. These probes in turn require ultra-small imaging lenses and associated scanning and beam director elements. There exists a need in the art for ultra-small  
10 optical probes capable of being used in diagnostic medical devices such as guidewires, catheters, endoscopes, bronchoscopes, needles, and trocars.

The design of ultra-small optical probes for medical diagnosis has been limited by constraints on lens size. GRaded INdex (GRIN) lenses coupled to a fold mirror have been used in the design of a 1 mm catheter. However, although able to image the aperture of a single-mode fiber  
15 onto a vessel wall, the GRIN lens catheter known in the art cannot be scaled smaller than 1 mm since the diameter of the GRIN lens itself is on the order of 1 mm.

Techniques for making very small lenses have been described in the literature. However, these lens have small working distances and although suitable for coupling into laser diodes, do not offer the > 1mm working distance and the > 1mm depth-of-field required to image the  
20 internal structures of a human body *in situ*. Microlenses also have been described that can be used for high-power (short focal length) designs. These type of lenses typically use balls or micro-tapers that yield an overall lens diameter bigger than that of a single-mode fiber or have focal lengths that are too short for imaging the internal structures of a body *in situ*. Microlenses that are designed specifically for highly multimode fibers pose different theoretical  
25 considerations than do lenses which may be used with single-mode fibers and those described in the art reduce the size of the original beam rather than increasing it.

- 2 -

The present invention provides an optical fiber-lens system which can deliver light from a single-mode fiber, providing minimum back-reflection and minimum loss of light while delivering a nearly diffraction limited image in the focal plane of a sample. The optical fiber-lens system in combination with beam steering and scanning elements can be used as an optical probe to navigate small, tortuous paths within the human body.

### **SUMMARY OF THE INVENTION**

The present invention provides an optical imaging probe comprising a single-mode optical fiber optically coupled to a lens which has substantially the same diameter as the optical fiber. In another embodiment of the invention, the optical imaging probe comprises a coreless fiber optically coupled to the single-mode fiber and the lens. In a further embodiment of the invention, the lens is in communication with a beam director.

The invention also provides an optical probe including a graded index lens. In another embodiment of the invention, the optical probe comprises a fold mirror. In one embodiment of the invention the fold mirror is spaced apart from the lens, while in another embodiment of the invention, the fold mirror is in physical contact with the lens.

The present invention also provides an optical probe having an optical fiber at least partially contained within a probe housing. In another embodiment, the probe housing is in the form of an insertional medical device, such as a guidewire, an endoscope, bronchoscope, a catheter, a needle, and a trocar.

The present invention also provides connectors to connect and disconnect the probe from an optical system. The connectors of the present invention have a first end for coupling to the probe housing of the optical probe and a second end for coupling to the optical system. In another embodiment of the invention, the probe housing is in the form of a guidewire and the first end of the connector has a diameter which is substantially the same size as the diameter of the guidewire.

In one embodiment of the invention, the optical probe comprises a pull back mechanism in communication with one of the housing and the optical fiber. Actuation of the pull back mechanism causes linear motion of at least one of the probe housing and optical fiber relative to the longitudinal axis of the optical fiber.

The present invention also provides an ultra-small lens for use with the optical probes. In one embodiment of the invention, the lens has a working distance of  $> 1$  mm. In a further embodiment of the invention, the depth of field of the lens is  $> 1$  mm. The invention also provides a method of manufacturing an ultra-small lens having these properties. In one

embodiment, a graded index fiber is spliced to a coreless fiber. The coreless fiber is then precision cleaved at a predetermined position and spliced to a single-mode fiber. The graded index fiber is then precision cleaved at a proper distance to produce a lens with desired optical properties (e.g., a large working distance and depth of field).

5 The invention also relates to a method of measuring the optical properties of a test sample *in situ*. An optical probe is positioned in proximity to the test sample, the optical probe comprising a single-mode optical fiber optically coupled to a lens which is substantially the same diameter as the optical fiber. An optical beam is then transmitted from the optical probe to a sample *in situ* and light transmitted from the sample is detected.

10

### **BRIEF DESCRIPTION OF THE DRAWINGS**

The foregoing and other objects, features, and advantages of the present invention, as well as the invention itself, will be more fully understood from the following descriptions of preferred embodiments, when read together with the accompanying drawings, in which:

Figure 1 shows the relationship between resolution and depth of field for a Gaussian beam.

15

Figures 2A-E show optical fiber-lens systems having different types of microlenses according to embodiments of the invention.

Figure 3 is a graph showing the relationship between beam waist size and lens radius of curvature.

20

Figure 4 shows an optical probe according to one embodiment of the invention including a single-mode optical fiber and a lens which is substantially the same diameter as the optical fiber.

Figure 5 shows an optical probe according to one embodiment of the invention including a fold mirror spaced apart from a microlens.

Figure 6 shows an optical probe according to one embodiment of the invention including a fold mirror in physical contact with a microlens.

25

Figure 7 shows an optical probe according to one embodiment of the invention directing a beam for forward imaging of a sample.

Figure 8 shows an optical probe according to one embodiment of the invention where the probe includes a housing in the form of a guidewire.

30

Figures 9A-C show views of a quick disconnect unit according to one embodiment of the invention. Figure 9A shows a connector in the form of a ferule. Figure 9B shows a quick disconnect unit in which the ferule and optical probe are seated within a quick disconnect housing. Figure 9C shows an enlarged view of a quick disconnect unit where the unit includes a split-sleeve.

- 4 -

Figure 10 shows an optical probe having a spring at the tip according to one embodiment of the invention and adapted for use as an imaging guidewire.

Figures 11A-C show an optical probe according to one embodiment of the invention in which the probe housing is covered by a spring.

5 Figure 12 shows a schematic diagram of a window in the housing of an optical probe according to one embodiment of the invention.

### **DETAILED DESCRIPTION OF THE INVENTION**

The present invention discloses the design of an ultra-small optical imaging probe that can perform circumferential imaging of a sample. The invention also provides methods of  
10 manufacturing the micro-optical elements (e.g., microlenses and beam directors) that form the distal imaging optics of such a probe. The present invention provides probes with lenses less than ~300  $\mu\text{m}$  in diameter which simultaneously have a working distance that can extend up to several millimeters.

#### **Micro-Optical Elements**

15 For many imaging systems (e.g., OCT imaging systems), light is emitted from an single-mode optical fiber and focused on a sample using a lens. Retro-reflected light is then coupled back through the lens into the fiber. In contrast to optical systems which rely on multimode optical fibers where the beam waist location and the classical image location are nearly coincident, in optical systems including single-mode optical fibers which emit a nearly Gaussian  
20 beam, the waist location and the classical image location can be significantly different. This difference must be taken into account when designing lens to be coupled with single mode optical fibers in order to attain the desired image location and depth of field.

In OCT and other imaging or light delivery/collection applications, the best optical performance is obtained when light impinges on a sample that is located within the depth of field  
25 of the lens. This ensures that any light back-reflected from a sample will be efficiently directed back through the single mode fiber. Light back-reflected farther and farther outside the working distance of the lens is received less and less efficiently by the single-mode optical fiber and hence is less detectable by the imaging system. Increasing the depth of field of the lens allows an optical probe to image farther into a vessel or space into which the probe is inserted. Figure 1  
30 shows the relationship between the spot size of a light beam transmitted through a single-mode optical fiber and the depth of field that can be generated assuming a Gaussian beam and a working distance of 3 mm. The trade-off between depth of field (e.g., 1, 2, 3, 4, and 8 mm) and corresponding beam spot size (14, 20, 25, 29, and 41  $\mu\text{m}$ ) for a wavelength of 1.33  $\mu\text{m}$  is clearly

- 5 -

apparent. The depth of field is inversely related to the square of the beam spot size; thus, decreasing the beam spot size concurrently decreases the depth of field. Thus, the challenge in making small optical systems has been to achieve a both a large working distance and a large depth of field and still maintain a small optical probe diameter and small beam spot size. Optical systems having small beam spot sizes *and* large working distance have previously only been  
5 obtained at the expense of increasing lens size, and therefore ultimately at the expense of increasing the size of the optical probe.

In small optical imaging probes known in the art, a single-mode fiber 125  $\mu\text{m}$  in diameter is typically glued to a commercial 700  $\mu\text{m}$  Graded Index (GRIN) lens using ultraviolet-cured  
10 optical adhesive ("UV glue"). The GRIN lens in turn is UV-glued to a 700  $\mu\text{m}$  fold mirror, such as a prism, forming an optical chain comprising the single-mode optical fiber, the GRIN lens, and the fold mirror. The proximal end of the GRIN lens is fixedly held within a rotatable torque cable. The entire assembly (i.e., optical chain and torque cable) is contained within a sheathing. The sheathing is typically transparent to the wavelength of light contained with the single-mode  
15 fiber or includes a transparent window near the fold mirror.

While this type of imaging optical probe can achieve the resolution, depth of field, and beam spot sizes illustrated in Figure 1, it does so at the expense of size. The entire assembly of such a probe is approximately 1 mm in diameter even though the optical fiber within the device is only 125  $\mu\text{m}$  in diameter and the largest beam size required to obtain a suitable working distance for  
20 imaging is less than 100  $\mu\text{m}$  (see Figure 1). This large diameter limits the use of probes known in the art to imaging openings significantly greater than 1 mm. In the human body (and in other non-medical applications) there is a pressing need to miniaturize the diameter of the imaging probe so that smaller vessels can be navigated. For example, guidewire applications require that the entire outside diameter of the guidewire may be only 350  $\mu\text{m}$  in order to fit in most catheter  
25 devices. However, typical optical probes have difficulty in being scaled down to the diameter required for a guidewire because the lenses of such probes typically have a diameter on the order of 1 mm.

Most small optical probes known in the art also suffer from large back-reflections of light as it is difficult to match the indices of refraction of the various optical elements of the probe (e.g.,  
30 lens and fold mirror/prism) to each other. These back-reflections can significantly impact the quality of images obtained, particularly in OCT applications where large back-reflections lead to an effect known in the art as blindness – whereby a large reflection tends to saturate the front-

- 6 -

end electronics of the detecting component of the imaging system, rendering small reflections generated by the actual sample undetectable.

The present invention provides methods to design miniature lenses **2** (~250  $\mu\text{m}$  in diameter) that can achieve optical parameters similar to those shown in Figure 1.

5 In different embodiments of the invention, microlens **2** are provided which include the following optical properties:

- A lens **2** diameter of less than about 300  $\mu\text{m}$  (preferably less than about 150  $\mu\text{m}$ );
- A working distance  $>1$  mm;
- 10 • A depth of field  $>1$  mm;
- A spot size of  $<100$   $\mu\text{m}$ ;
- Ability to work within a medium with an index of refraction  $>1$  (e.g., within a saline or blood-filled environment) without destroying the image quality;
- Ability to rotate or perform circumferential scanning within a 400  $\mu\text{m}$   
15 diameter housing;
- Ability to achieve  $>20\%$  coupling efficiency from a fold mirror **3** located at the beam waist location of the lens **2**; (Coupling efficiency is defined here as the amount of light energy recoupled or redirected by the lens **2** system back into the fiber **1**.)
- 20 • Minimal back-reflections; and
- Ability to use as part of an ultra-small optical probe which forms a guidewire apparatus.

Figures 2A-E show microlenses **2** that can be manufactured efficiently according to the methods disclosed herein while achieving the parameters listed above. There are two basic types  
25 of lenses **2**: (1) lenses **2** that use a radiused end (Figures 2A-D) and (2) lens **2** that use a longitudinal or radially varying index (e.g., GRIN lenses) (Figure 2E). Combinations of both types of lens may also be used. In a preferred embodiment of the invention, all of the lenses **2** are optically coupled to a single-mode fiber **1**. A single-mode optical fiber **1** typically consists of an 80  $\mu\text{m}$  or 125  $\mu\text{m}$  cladding and a 4 to 10  $\mu\text{m}$  core as is known in the art.

30 In order to achieve the working distances and optical parameters shown in Figure 1, the lens **2** typically cannot be directly affixed to the single-mode fiber **1** because it is necessary that an optical beam transmitted through the optical fiber **1** first expand to the required beam diameter

- 7 -

prior to being focused by the lens 2. In one embodiment of the invention, the space between the lens 2 and the single-mode fiber 1 is filled by a coreless fiber 8. The length of the coreless fiber 8 is calculated by selecting optical properties the user desires in the optical probe. For example, to image (in air) with a 4 mm depth of field, a 29 μm spot size, and a 3 mm working distance  
 5 would require ~ 810 μm of coreless fiber 8 followed by a lens 2 with a spherical surface having a radius of curvature of ~225 μm.

Figure 3 shows the relationship between the beam spot size and the lens 2 radius of curvature for a coreless fiber 8 having a length of ~810 μm and lenses 2 with varying radii of curvature. The design of the lens 2 system can be accomplished with knowledge of Gaussian beam  
 10 propagation which is well detailed in many standard textbooks. The equations as applied to the newly disclosed microlenses 2 are outlined below.

First, single-mode Gaussian beams expand from their minimum (the “waist”) according to the well-known relationship:

$$\omega(z) = \omega_0 \sqrt{1 + \left(\frac{z}{z_0}\right)^2} \quad (1)$$

15 where  $\omega(z)$  is the beam radius at location  $z$ ,  $\omega_0$  is the beam waist which occurs by definition at  $z=0$ , and  $z_0$  is the Rayleigh range and is the distance at which the peak intensity falls to ½ of its value as measured at the beam waist. The Rayleigh range is given by  $\eta\pi\omega_0^2/\lambda$ , where  $\lambda$  is the wavelength of the light in a vacuum, and  $\eta$  is the index-of-refraction of the medium. The Rayleigh range thus dictates the depth of field of the lens 2, which is typically defined as twice  $z_0$   
 20 and is often called the confocal parameter. As shown in Figures 1 and 4, the distance from the waist location of the imaged beam back to the lens 2 surface is defined here as the working distance of the lens 2.

Second, the radius of curvature,  $R(z)$ , of a Gaussian beam follows another well-known relationship:

$$25 \quad R(z) = z_0 \left( \frac{z}{z_0} + \frac{z_0}{z} \right) \quad (2)$$

Equation 2 demonstrates that a Gaussian beam has an infinite radius of curvature (i.e., flat phase front) at the beam waist, and that at distances which are large compared to the Rayleigh range, a Gaussian beam will propagate much like a spherical wave centered at  $z = 0$  and can be treated in this regime with classical (geometrical) optics. In the case at hand, however, the  
 30 desired working distances ( $z$ ) and depth of fields ( $z_0$ ) are comparable and classical optics cannot



- 8 -

be used effectively. To solve this problem, a desired working distance and depth of field for lens 2 are chosen. These parameters determine the required beam waist size to be created by the lens 2. The required waist size and desired location of the beam waist in space in turn determine the required beam size, as well as the phase front radius of curvature (of the outgoing beam) at the lens 2 surface. Thus, the coreless fiber 8 between the single-mode fiber 1 and the lens 2 must allow the beam to expand from the exit of the single-mode fiber 1 to match the beam size required at the surface of the lens 2. The coreless fiber 8 must also bend the phase front of the incoming beam from the sample to match that of the outgoing beam transmitted through the single-mode fiber 1. Hence, the coreless fiber 8 and the lens 2 radius of curvature are uniquely determined given two input requirements (and given the single-mode fiber geometry and wavelength) – working distance and depth of field.

Using Equations 1 and 2 above, and assuming that the radial distances are small when compared to the longitudinal distances (the well-known paraxial approximation, a valid assumption for long-working-distance lens 2 designs as described herein), a simple relationship can be derived for the required radius of curvature:

$$\frac{1}{R_{lens}} = \frac{n_0}{n_1 - n_0} \left( \frac{1}{R_f} + \frac{n_1}{n_0 R_i} \right) \quad (3)$$

where  $R_{lens}$  is the radius of curvature of the lens 2 surface,  $n_1$  is the index of the coreless fiber 8,  $n_0$  is the index of the medium (nominally air or saline) in which the new waist is formed, and  $R_i$  and  $R_f$  are the curvatures of incoming and outgoing Gaussian beams, respectively. The required length of the coreless fiber 8 can be easily calculated using Equation 1. Thus, using the calculations described above (for a fixed lens 2 length and which is parameterized by the length of the coreless fiber 8), the appropriate radius of curvature of a lens 2 required to achieve the properties of large working distance and depth of field and small beam spot size may be determined.

Figure 3 is a graph showing the relationship between the beam spot size and the location of the beam waist for lenses 2 having a variety of curvatures calculated in this manner. It can be seen that a lenses 2 with a steep curvature (small radius of curvature) produces the smallest beam waist at the shortest distance as expected. Note that these equations are approximate and that more detailed and precise analysis can be preformed using commercially available physical

- 9 -

optics design packages. These include, but are not limited to, CODE V (Optical Research Associates, Pasadena, California), OSLO (Sinclair Optics, Inc., Fairport, New York) and GLAD (Fraunhofer IAO, Stuttgart, Germany) commercial optical beam and design packages.

Figure 4 is a schematic showing the properties of an optical beam obtained from an optical probe which includes the microlens **2** discussed above. In one embodiment, a single-mode fiber **1** is spliced or otherwise secured to the lens **2**. The lens **2** is approximately the same diameter as the single-mode optical fiber **1**. The optical fiber **1** may include a variety of thin coatings to ruggedize it which can be commercially purchased from Corning® (Corning Incorporated, Corning, New York), Spectran® (Spectran, Sturbridge, Massachusetts), and other commercial fiber optic companies. A 90 degree (or other suitable angle) fold mirror **3** is affixed to the lens **2** also using splicing or glue. The fold mirror **3** is coated with a high reflectance material or operates in total internal reflection. In one embodiment, the fold mirror **3** is made of metal and is located separately from the lens (e.g., as shown in Figure 5). In another embodiment of the invention, the fold mirror **3** is made by polishing another section of coreless fiber on a 45 degree (or other angle for forward or backward scanning) which is then metal- or dielectric-coated. In a further embodiment of the invention, the fold mirror **3** has a dichroic coating to allow one wavelength to reflect and one wavelength to simultaneously transmit through the mirror **3**.

It should be noted that although fold mirrors **3** are described in examples throughout the specification, any type of optical element which can steer a light beam and serve as a beam director **3** is encompassed within the scope of the invention. Thus, the terms “beam director” **3** and “fold mirror” **3** are used interchangeably herein.

As can be seen in Figure 4, the design of the microlenses **2** of the present invention minimizes the beam spot size at the working distance of the lens **2** and creates a nearly flat phase front of the beam at this location, i.e., forming a beam waist at a spot located at the working distance of the lens. The equations disclosed above predict a working distance (defined here as the beam waist distance as measured from the apex of the lens **2**) of 3mm for a lens 810  $\mu\text{m}$  in length, with a radius of 225  $\mu\text{m}$ , an operating wavelength of 1.32  $\mu\text{m}$ , and a material index of refraction of 1.45.

Referring again to Figures 2A-E, in one embodiment of the invention, coreless fiber **8** region is directly attached to a single-mode fiber **1**. As discussed above, in the coreless fiber **8** region an optical beam transmitted through the single-mode optical fiber **1** can gracefully expand to the required diameter of the lens **2** prior to focusing by the lens **2**. The coreless fiber **8** can have the same diameter as the single-mode fiber **1** cladding and can be directly fusion-spliced using

- 10 -

standard fusion splicer equipment, such as an Ericsson Fusion Splicer (Amherst Instruments, Amherst Fiber Optics, Brentwood, Tennessee) ,ensuring low loss, solid adhesion, and preservation of the single-mode Gaussian beam characteristics. Preferably, the coreless fiber **8** is index-matched to the single-mode fiber **1** to ensure minimum back-reflection and loss.

5       The optic fiber **1**-lens **2** assemblies in Figure 2A-D use lenses **2** with curved surfaces. The length of the coreless fiber **8** region and radius of curvature of the lenses **2** are chosen to obtain the required beam parameters (i.e., beam spot size, depth of field, and working distance) such as those shown in Figure 1 and described previously. A number of methods of manufacturing the required lenses **2** are encompassed within the scope of the invention. These include using heat  
10       from a fusion splicer to melt the end of a coreless fiber **8** where surface tension will create a nearly circularly symmetrical lens **2** (Figure 2A). In this embodiment, the fusion time and fusion current (heat) of the fusion splicer are adjusted and the manufacturer manipulates the end of the coreless fiber **8** relative to the fusion arc produced by the fusion splicer. Typically, to make large radius of curvature lenses **2** it is beneficial to run a relatively cool fusion arc (8-10 mA on an  
15       Ericsson fusion splicer, for example) for a long time (1 - 30 seconds) or to make a long series of very short, high temperature fusion spikes. In a further embodiment of the invention, it is possible to test the radius of curvature of the lens **2** in real-time by monitoring the output using a high magnification microscope between fusion treatments or by removing the lens **2** and placing it into a beam profiling device such as those available from Beamsan (Photon, Inc., Santa  
20       Clara, California). This way the recipe for the particular fusion splicer (or other heat treatment method) can be optimized for the particular lens parameters desired by an iterative method.

      In a further embodiment of the invention (Figure 2B), a small drop of UV or other suitable glue can be placed using a micropipette and cured on the end of the coreless fiber **8**. When assembling a lens with the UV glue technique, it is preferable to select a volume of glue and a  
25       type of glue with the proper surface tension and viscosity so that upon placing the glue on the end of the coreless fiber **8**, surface tension and viscosity cause the glue to "ball-up" with the desired surface profile and radius. With a large volume of glue approximately equal to a hemisphere on the end of the coreless fiber **8**, the radius of curvature will approximately equal the radius of the coreless fiber **8** (and therefore, also the radius of the single-mode fiber **1**). For  
30       smaller glue volumes, the radius can be increased to approximately 5 to 10 times the radius of the coreless fiber **8**.

      The radius of curvature of the lens **2** can further be slightly modified by locating the coreless fiber **8** vertically, with gravity pulling the glue down, to flatten the radius of curvature . In

- 11 -

another embodiment, the coreless fiber **8** is held upside down to slightly increase the radius of curvature. The amount of glue can be controlled using a micropipette or by sequentially transferring a large ball of glue from the end of one fiber to a coreless fiber **8** without any glue. The volume of the glue will tend to decrease by a factor of two for each transference. Other  
5 methods known by those skilled in the art can be used to setting the proper volume of glue to be placed on the end of the coreless fiber **8** and cured.

Commercially available ball lenses (with appropriate shaping) **2** can also be shaped to a diameter nearly equal to the single-mode optical fiber **1** diameter and secured to the end of the coreless fiber **8** using UV or another suitable glue as shown in Figure 2C. This can be  
10 accomplished by polishing the ball lenses **2** to form small, thin hemispheres or by coring the ball lenses **2** to form rod lenses **2**.

Finally, the end of the coreless fiber **8** distal to the single-mode fiber **1** can be mechanically ground using grinding and polishing techniques known in the art. In this embodiment, the end of the coreless fiber **8** forms the lens **2** as shown in Figure 2D. Ideally, the coreless fiber **8** is made  
15 to have the same index of refraction as the lens **2** to minimize loss and back-reflections of the optical beam transmitted from the single-mode fiber **1**. In this embodiment, the coreless fiber **8** and lens **2** are one integral unit.

In a further embodiment of the invention, radiused lenses **2** may be manufactured using reflow technology whereby a material (e.g., polymethyl methacrylate (PMMA)) is deposited on  
20 the end of the coreless fiber **8** and heated so that material reflows to form a nearly circularly symmetrical lens **2**.

In another embodiment of the invention, the radiused microlenses **2** of Figures 2A-D, as well as the flat lens **2** shown in Figure 2E, can be affixed to an external fold mirror **3**, as shown in Figure 5. The fold mirror **3** is metered (or registered) with respect to a lens **2** using a clear  
25 plastic or glass metering tubing or cover **9** of optical quality. Other types of metering are possible and encompassed within the scope of the invention. In one embodiment, a metal or non-optically transparent media is used and a small hole is cut or placed at an appropriate location with respect to the fold mirror **3**. If a small hole is cut or placed at the appropriate location above the fold mirror **3** to permit an optical beam to pass through the hole, the diameter  
30 of the metering tubing **9** (and thus the total outer diameter of the lens **2**/beam director **3** assembly) can easily be made to less than 250  $\mu\text{m}$ .

It is important to minimize the cylindrical lens effects of the metering tubing **9** shown in Figure 4. This cylindrical lens effect may be compounded when the ultra-small optical probe is

- 12 -

placed in saline or in another environment such as blood. In this case, the cylindrical surface of the tubing 9 (combined with the index of the sample medium) may act as a cylindrical lens more powerful than microlens 2 and can become a major detriment to the imaging quality of the system. However, the present invention provides methods to circumvent this effect. In one embodiment, a plastic metering tubing 9 is used and a flat spot 9fs is created in the tubing 9 by heat-treating the tubing 9.

Alternatively, it is possible to index-match the tubing 9 material to the sample medium. For example, if the probe is to be placed in saline or blood, both having an index of refraction of ~1.3, then the tubing 9 is made with a similar index of refraction, i.e., ~1.3. In a further embodiment of the invention, an optical transmitter is placed between the lens 2 and the fold mirror 3 which also has a similar index of refraction of ~1.3. When index-matching the lens 2, it is important to use a lens 2 that has a radiused end (Figures 2A-3D) to take into account differences between the refractive indices of the sample medium, the optical transmitter and the lens 2. Lenses 2 that have an aspheric surface are also within the scope of the invention.

Aspheric lenses are most easily made using the reflow technology described above. Finally, another method of avoiding the cylindrical lens effect of the metering tubing 9 is to simply avoid using a metering tubing 9 which is cylindrical. In one embodiment of the invention, the metering tubing 9 is made from commercially available square tubing (plastic or glass). Square tubing can also be made in several ways, such as by heat shrinking over a square metal wire or glass fiber, by extruding the tubing square, or by blow molding the tubing.

For many applications, the last lens 2 shown in Figure 2E is the preferred embodiment. This lens 2 can be made in several ways. In one embodiment of the invention, a lens 2 having a graded index of refraction is used. In this embodiment of the invention, radial (or longitudinal) variation in the index of refraction of the GRIN lens 2 causes the phase front of the light beam transmitted through the optical fiber 1 to be bent in a way which is analogous to the phase bending obtained from a conventional curved-surface lens. Materials for such lens 2 are commercially available and are known in the art as GRIN materials. Ideally, the gradient profile of the lens 2 is selected to be cylindrically symmetric and to decrease with a quadratic (or nearly quadratic) dependence on the radial distance from the center of the lens 2 as described in the following equation:

$$n(r) = n_c(1 - (A/2)(r/a)^\alpha) \quad (4)$$

- 13 -

where  $n(r)$  is the index of refraction,  $n_c$  is the index of refraction in the center of a selected fiber to which the GRIN lens is attached (the GRIN lens may be either a single-mode, coreless, or a type of multimode fiber),  $r$  is the radius,  $A$  is the index gradient coefficient,  $a$  is the core radius, and  $\alpha$  is the index power, which for a quadratic profile has a value of  $\sim 2$ . To minimize total back reflection, the center index of the lens **2** would be made to match the single-mode fiber **1** core (or the coreless fiber **8**) index. The equivalency of a GRIN lens **2** ( $\alpha = 2$ ) to a conventional lens is approximated by the following equation:

$$\frac{n_1 - n_0}{R_l} = n_c \frac{A}{a^2} l_{grin} \quad (5)$$

10

where  $l_{grin}$  is the length of the GRIN lens **2** required, and the other parameters are as given earlier.

It is possible to use standard or custom multimode optical fiber that has a nearly quadratic index profile to make these lenses **2**. Typical values of  $\alpha$  for lenses used in telecommunications applications have a value of 1.8-1.9. Values of  $\alpha$  close the ideal of 2.0 have been demonstrated both experimentally and theoretically to achieve acceptable Gaussian beam imaging. Thus, using commercial multimode fiber as a lens **2** material is a viable option. It is well-known that once a fiber "pre-form" (typically a large cylinder weighing several kilograms) is created with a given index gradient, it is possible to "pull" the final fiber to almost any desired diameter and thus achieve a variety of lens power and length combinations as can be seen from Equation (5). Further, it is even possible to post-machine a lens preform to change the core-to-cladding ratio and thus achieve an even wider variety of possible GRIN lenses **2**. Thus, there are a variety of techniques available which allow one to take standard telecommunications fiber pre-forms and to modify the final fiber to suit the current purpose.

In one embodiment of the invention, multimode lenses with graded index profiles are made by using an industry-standard SMF-28 single-mode fiber **1** as the primary light guide, attaching  $\sim 750 \mu\text{m}$  of coreless fiber **8** (for beam expansion), and then attaching  $\sim 100 \mu\text{m}$  of multimode fiber ( $\alpha$  of 1.8,  $A$  of 0.038) to the coreless fiber **8**. The multimode fiber then serves as the lens **2**. The multimode fiber is precision cleaved at a predetermined position based on calculations described above to achieve a desired working distance and depth of field.

30

- 14 -

A graded index lens **2** made by the disclosed method can achieve a beam waist radius size of ~30  $\mu\text{m}$  and a beam waist location of nearly 2 mm from the fiber tip of the optical probe (i.e., the distal end of the GRIN lens). The lens **2** has a very high Gaussian beam quality, where quality is defined as the deviation of the measured beam intensity profile from the ideal Gaussian profile.

5 Beam quality is important, both for image quality considerations, and for light recoupling efficiency considerations. The multimode fiber forming the lens **2** can be similar to standard Spectran® 62.5/125 multimode fiber. However, it is also desirable to have a larger ratio of core to cladding. In one embodiment of the invention, fiber similar to 62.5/125 multimode fiber is ordered from commercial sources (e.g., Lucent® Technologies, Murray Hill, New Jersey;  
10 SpecTran Specialty Optics, Avon, Connecticut) and the fiber is drawn to the size of 105/125 multimode fiber. The graded index profile is then simply scaled down from 62.5 to 105  $\mu\text{m}$  in diameter.

The coreless fiber **8** can be eliminated if the gradient coefficient is reduced enough to allow the beam to expand to its required diameter while traversing the GRIN lens **2**. Commercially  
15 available multimode fiber as well as GRIN lens known in the art have a gradient coefficient that is too strong (i.e., an  $\alpha$  coefficient that is too large) for the designs presented here. However, the present invention provides methods to achieve customized gradients. To calculate the required GRIN gradient profile for a lens **2**, the standard ABCD matrix formalism for treating Gaussian beam propagation in the paraxial approximation can be used. The ABCD matrix describing the  
20 propagation from a single-mode fiber **1** through a GRIN material and into the medium interface is given by:

$$\begin{bmatrix} A & B \\ C & D \end{bmatrix} = \begin{bmatrix} \cos(l_{grin} A') & \frac{n_{smf}}{n_c} \sin(l_{grin} A') \\ -\frac{n_c A}{n_0} \sin(l_{grin} A') & \frac{n_{smf}}{n_0} \cos(l_{grin} A') \end{bmatrix} \quad (6)$$

25 where  $A'$  is  $(\sqrt{A})/a$ , and  $n_{smf}$  is the index of the single-mode fiber **1**. The ABCD law for the transformation of Gaussian beams can be used to solve for the  $A'$  parameter given the other material parameters and, as before, the desired depth of field and working distance. With some algebraic manipulation, two equations can be derived:

- 15 -

$$\frac{1}{\omega_f^2} = \frac{1}{\omega_i^2} \left( \cos^2(l_{grin} A') + \left( \frac{n_c A' \pi \omega_i^2}{\lambda} \right)^2 \sin^2(l_{grin} A') \right) \quad (7)$$

$$\frac{1}{W_D} = \left( \frac{n_{smf}}{n_0} \right)^2 \frac{1}{\sin(l_{grin} A') \cos(l_{grin} A') \left( \left( \frac{\pi \omega_i^2}{\lambda_{smf}} \right)^2 \frac{n_c A'}{n_0} - \frac{n_{smf}^2}{n_c n_0 A'} \right)} + \frac{n_c A' \sin(l_{grin} A')}{n_0 \cos(l_{grin} A')} \quad (8)$$

5 where  $w_f$  is the final (imaged) beam waist radius,  $w_i$  is the initial beam waist radius at the exit of the single-mode fiber **1**,  $\lambda$  is the free-space wavelength,  $\lambda_{smf}$  is the wavelength inside the single-mode fiber **1**, and  $W_D$  is the working distance (e.g., location of the imaged waist). For example, given a desired depth of field of 4 mm and a working distance of 3mm, with  $\lambda$  equal to 1.32  $\mu\text{m}$ , Equations (7) and (8) can be iteratively solved to yield  $A' = 1.2074 \text{ mm}^{-1}$  and  $l_{grin} = 1.41 \text{ mm}$ ,  
 10 starting with standard Corning® SMF-28 fiber and imaging in air. Again these formulae are approximations to the exact solution and it is possible to use numerical optical design software, such as CODE V (Optical Research Associates, Pasadena, California), OSLO (Sinclair Optics, Inc., Fairport, New York) and GLAD (Fraunhofer IAO, Stuttgart, Germany), to get more precise lens **2** designs, although these models are not as instructive as the equations presented above.

15 Elimination of the coreless fiber **8** region results in a significant savings in the complexity of the lens **2** system as the number of fusion splices and precision cuts is reduced two-fold. Another advantage of customizing the GRIN material is that the effects of the fold mirror **3** (i.e., the impact of additional optical length and material indices) can be incorporated into the algebraic equations discussed above and/or into physical models so that the A coefficient can be  
 20 optimized for the complete system including beam director/fold mirror **3**.

One significant advantage of the lens **2** system in Figure 2E over the radiused lenses **2** shown in Figures 2A-3D is that an optical probe comprising this type of lens **2** can be immersed in saline or in another environment (e.g., blood or tissue) with an refractive index not equal to 1 and can still be used to image. The reason for this is that while conventional lenses perform all of the  
 25 bending of the phase front of the light beam from the optical fiber **1** directly at the interface *between* the sample medium and lens medium, GRIN materials perform the phase bending *within* the GRIN medium itself. Moreover, as shown in Figure 6, an integral fold mirror **3** can be directly attached to the lens **2**.



- 16 -

In one embodiment of the invention, the fold mirror **3** is be made by purchasing “D-core” fiber (i.e., a fiber formed in the shape of the letter “D”) or square fiber (such as obtained from Lucent Technologies, Murray Hill, New Jersey, SpecTran Specialty Optics, Avon, Connecticut) or by polishing a fiber to have a flat facet along its length to create the desired D-shape. The D-  
5 fiber is then spliced onto a GRIN/multimode fiber lens **2** and the end is polished on a 45 degree angle (or other suitable angle for forward or reverse imaging) to reflect the outgoing beam from the single-mode optical fiber **1** through the flat of the D (thus avoiding parasitic cylindrical lens effects). The mirror **3** can then be either metal -or dielectric-coated or, as mentioned above, can  
10 be coated with a dichroic beam splitter to allow simultaneous forward and side imaging via different wavelengths. Alternatively, if the angle of the fold mirror **3** is greater or less than the angle for total internal reflection of the fold mirror **3**, as given by Snell's law (~45 degrees in silica/air interface), then it is not necessary to coat the mirror **3**.

The total diameter of the optical lens **2** /fold mirror **3** in Figure 6 can easily be made less than 250  $\mu\text{m}$  while obtaining the desired beam parameters (e.g., as shown in Figure 1). Further, the  
15 lens **2** can be made using standard fusion splicing and polishing techniques, and thus can be low cost, with minimal back-reflections and maximal performance. It is also possible to make the integral fold mirror **3** of Figure 6 by first fusion splicing a short section of coreless fiber **8** to the GRIN lens **2**, then polishing the edge of fold mirror **3** flat or on a slight angle. In a further  
20 embodiment of the invention, it is possible to make a section of a coreless fiber **8** square-shaped or D-shaped during the fiber draw to form the fold mirror **3**. The fold mirror **3** can also be made using polishing, cleaving, or sawing techniques.

In another embodiment of the invention shown in Figure 7, a section of a coreless fiber is optically coupled to the lens **2** and is placed between the lens **2** and the sample to act as a beam  
25 director **3**. In this embodiment, the beam director **3** is polished on an angle to yield a prism effect. If the beam director **3** is then spun circumferentially, the beam transmitted through the single-mode optical fiber **1** will sweep out, or scan, a conical section. Such a scan can be useful for applications where the probe is adapted for use as an insertional medical device, such as a small guidewire, catheter, endoscope, bronchoscope, needle, or trocar.

### **Imaging Applications For Ultra-Small Optical Probes**

30 The invention provides ultra-small optical probes which can be used to measure the optical properties of a test sample *in situ*. In one embodiment of the invention, shown in Figure 8, the ultra-small optical probe is coupled to an optical system **16** and the probe is placed in proximity to a test sample(in this embodiment, a blood vessel **17**). An optical beam is

- 17 -

transmitted from the probe to the sample *in situ*; and light transmitted from the sample is detected. As defined herein, the term "*in situ*" means without removing the sample from its natural location and includes imaging internal vessels, spaces, or channels inside the body of a human being. As defined herein, the term "test sample" is used to refer to any sample for which  
5 measurements of optical properties are desired. The term "test" does not imply that the sample relates to a pathological condition or even that the optical properties of the sample are unknown; however, the probes and methods of the present invention may be used to diagnose and intervene in pathological conditions.

The invention also relates to connectors **12** and **15** which connect the ultra-small optical  
10 probes to optical beam delivery and imaging systems **16**. The connectors allow the user to quickly connect and disconnect a probe from an optical imaging system **16**, and in particular, from a driving mechanism which drives the optical probe to perform scanning of a sample. In one embodiment of the invention, the ultra-small optical probe comprises a housing **11** which is in the form of an insertional medical device and is used to image narrow, tortuous lumens or  
15 small spaces *in situ* within the body of an organism. Although medical applications are discussed further below, it should be clear to those of ordinary skill in the art that the ultra-small optical probes disclosed herein can be used to measure the optical properties of a variety of spaces (e.g., imaging channels or spaces in articles of manufacture) and that such applications are also encompassed within the scope of the present invention.

In one embodiment of the invention, the ultra-small optical probe comprises a probe housing  
20 **11** which is in the form of an insertional medical device. Figure 8 shows an embodiment of the invention in which the probe housing **11** is a guidewire. Other types of insertional medical devices are also contemplated, and are encompassed within the scope of the invention. These include, but are not limited to, , bronchoscopes, needles, endoscopes and trocars. The  
25 guidewires of the present invention may also be used as components of other insertional medical devices (e.g., adapted for fitting into the guidewire lumen of a catheter). Guidewire housing **11** materials include, but are not limited to, metal, plastic, hypotubes, and the like.

In one embodiment of the invention shown in Figure 8, the miniature optical fiber **1**/optics  
30 lens **2**/beam director **3** assembly of the ultra-small optical probe is housed inside a small guidewire housing **11** (typically < 0.018" in diameter). As shown, an OCT or other optical imaging or beam delivery system (e.g., a photodynamic therapy system or fluorescence system), is connected to the probe housing **11** via a rotatable fiber optic joint (RFOJ) **13** using detachable electrical connectors **12** and **15** and optical connectors (including single-mode fiber **1**). The

- 18 -

RFOJ **13** is used to circumferentially spin or rotate a single-mode fiber **1** or a miniature torque fiber within the probe housing **11**. This device can be similar to the one described in U.S.S.N: 08/607,787, filed 2/27/96, the entire disclosure of which is herein incorporated by reference.

Single-mode fibers **1** used in this embodiment of the invention are those known in the art and typically consist of a ~ 4-10  $\mu\text{m}$  core, a 80-125  $\mu\text{m}$  cladding, and a 250-900  $\mu\text{m}$  protective buffer. To minimize the diameter of the fiber **1** the protective buffer can be removed. Alternatively, the protective buffer can be replaced with a relatively thin (1  $\mu\text{m}$  to 50  $\mu\text{m}$ ), high strength, low friction coating to fit within the small opening defined by of the optical probe housing **11**. Such high strength coatings can be obtained from commercial fiber houses such as Corning® and Spectran®. Thus, the single-mode fiber **1** can be directly torqued to perform rotational scanning or a miniature torque cable can be added to aid in torching the fiber **1**. It is important that the internal diameter of the guidewire housing **11** be made to have minimal friction and burrs.

In one embodiment of the invention, the output of the RFOJ **13** is connected to a disposable connector **12** that consists of an FC/APC male to female connector with minimal loss and back-reflections. In a further embodiment of the invention, disposable connector **12** is used to cross the sterile/non-sterile boundary **14**. In another embodiment of the invention, the RFOJ **13**, as well as the connector **12**, are housed in a disposable sterile bag to allow repeated use of the RFOJ **13** by eliminating contaminants. The bag covers the RFOJ **13** and associated proximal coupling hardware to prevent any patient or sample bodily contaminants from touching the hardware. Thus, after a patient exam the bag can be removed and thrown away without the need to sterilize the RFOJ **13** and proximal coupling hardware. Such bags are standard in intravascular ultrasound devices and are required in such medical procedures by the Food and Drug Administration.

In one embodiment of the invention, the output of the disposable connector **12** is connected to a quick disconnect unit **15**. The purpose of the quick disconnect unit **15** is to allow the physician/user to quickly disconnect both the guidewire housing **11** and another insertional or interventional medical instrument to which the guidewire housing **11** is coupled from the disposable connector **12** and RFOJ **13**. The other insertional/interventional medical device is then passed over the guidewire housing **11** for interchange with still other devices or for manipulation by the physician/user. Insertional/interventional medical devices to which the guidewire housing **11** may be coupled include, but are not limited to, a pass or exchange

- 19 -

catheter, a balloon angioplasty device, a stent delivery device, an artherectomy catheter, and a drug delivery device.

For example, if the physician is viewing an arterial lesion in a blood vessel **17** that he/she determines will require an interventional procedure, he/she quickly disconnects the guidewire housing **11** from the RFOJ **13** via the quick disconnect unit **15** (shown in Figures 8 and 9), slides  
5 a suitable interventional device over the guidewire, reconnects the housing **11** to the RFOJ **13**, and begins imaging using imaging system **16**. Using an imaging display output of the imaging system **16** physician/user can easily see when the interventional device is over the lesion. By being able to watch the placement of the interventional device during the interventional  
10 procedure the physician/user can inspect the lesion after the interventional device is removed.

In further embodiments of the invention, the physician uses the guidewire probe and the interventional device in an atherectomy procedure (or other surgical cutting procedure) where the optical probe allows the physician/user to determine where to cut. In a further embodiment of the invention, the interventional device used in conjunction with the guidewire probe is a drug  
15 delivery device where the image produced on a display screen of the optical system **16** allows the physician/user to determine how much of a drug to inject per unit time. In a further embodiment of the invention, the optical imaging system **16** used is an OCT system and the interventional device used is a stent. In this embodiment of the invention, the length and type of stent is determined before the procedure and the amount of inflation of the stent is controlled as  
20 the stent is being deployed, using information obtained from the optical probe and imaging system **16**.

In the embodiment of the invention where the probe housing **11** is a guidewire, it is preferred that the diameter of that portion of the quick disconnect unit **15** which is adjacent to a first end of the guidewire housing **11** (the end closest to the disconnect unit **15**) not exceed the maximum  
25 diameter of the guidewire housing **11** (e.g., 0.014 inches) to allow the easy exchange of other insertional/interventional devices over the guidewire housing **11**.

Figures 9A-C show the mechanical design of the quick disconnect unit **15** according to one embodiment of the invention. In this embodiment, a single-mode fiber **1** which is polished (or cleaved) at one end is contained within ferules **18** having a 0.014" outside diameter (Figure 9A).  
30 The ferules **18** are generally tubular structures which can be made from a wide variety of materials including, but not limited to, ceramic, glass, metal and plastic. The ferules **18** are precision-manufactured to tight tolerances both diametrically and between the inside and outside diameters of the ferules **18** and the single-mode optical fiber **1**/lens **2**/mirror **3**, to ensure proper

- 20 -

alignment between these optical elements. For example, if the core diameter of the optical fiber 1 is  $\sim 5 \mu\text{m}$ , then the tolerance is less than  $1 \mu\text{m}$ . To help alleviate the requirement for a tight tolerance, it is possible to use miniature lenses 2 similar to the lenses disclosed herein to increase the mode size of the fiber 1 and to collimate light between facets of the fiber 1. This would then allow a dramatic increase in the alignment tolerances required. A rough rule of thumb is that the alignment tolerance is approximately 10% of the beam diameter at the lens 2 facet. In a further embodiment of the invention, the ferule 18 is also keyed and angle-polished (as is done with commercial FC/APC connectors) to minimize back-reflections.

The polished single-mode optical fiber 1/lens 2/mirror 3/ferule 18 assembly is then fit within a ferule collar 19 (Figure 9B). The ferule collar 19 is slit radially (the slit not visible on this scale drawing) to the center to facilitate side loading of the single-mode optical fiber 1/lens 2/mirror 3 /ferule 18 assembly into the housing 23 of the quick disconnect unit 15. Slitting the components radially allows the single-mode optical fiber 1/lens 2/mirror 3 /ferule 18 assembly to be quickly removed from the quick disconnect unit 15 to facilitate passage of an insertional/interventional medical device over the probe housing 11. In a further embodiment of the invention, an elastomeric spring 22 is provided at the end of the ferule collar 18 closest to the housing 23 of the quick disconnect unit 15.

The single-mode optical fiber 1/lens 2/mirror 3 /ferule 18 assembly is set within an endcap 20 which is also radially slit (slit not visible in Figure 10B) to the center. The endcap 20 is screwed into a split sleeve 21 contained within the housing 23 of the quick disconnect unit until it can no longer be turned. As the endcap 20 is being inserted, the ferules 18 are being pressed into the split sleeve 21. The split sleeve 21 is cut axially to allow for radial expansion. It is manufactured with a precision inside diameter that is slightly smaller than that of the ferules 18. The split sleeve 21 is contained sufficiently loosely within the housing 23 of the quick disconnect unit 15 allowing it to self-center itself. Interference created between the inside diameter of the split sleeve 21 and the outside diameter of the ferules 18 is used to align the ferules 18 radially and to maintain concentricity with the split sleeve 21, the end cap 20, and the ferule collar 19.

In the embodiment of the invention where an elastomeric spring 22 is provided in proximity to the ferule collar 19, fully engaging the endcap 20 compresses the elastomeric spring 22, applying an axial load that forces the ferules 18 containing the optical fiber 1 and the split sleeve 21 together. In one embodiment of the invention, the elastomeric spring 22 is split radially to the center. The axial force created by the compressed spring 22 and the precision radial alignment

- 21 -

between the ferules **18** and split sleeve **21** creates a reliable optical connection between the optical elements of the ultra-small probe.

In a preferred embodiment of the invention, the probe housing **11** together with the portion of the connector device proximal to the probe housing **11** is not substantially greater in diameter than the outer diameter of a standard guidewire so that a physician/user can quickly disconnect the optical probe from the RFOJ **13** and exchange other medical devices over the probe housing **11** and connector elements. In a further embodiment of the invention, the split sleeve **21** and the housing **23** of the quick disconnect unit **15** are designed so that the distal side of the quick disconnect **15** (away from the optical imaging system **16**) includes a 0.014 inch ferule **18**, but the proximal side has a much larger ferule **18** (e.g., > 1mm). In this configuration, the quick disconnect unit **15** is compatible with standard commercially available fiber optical connectors.

In another embodiment of the invention, the RFOJ **13** is also coupled to a longitudinal translation/pull back device **25** as shown in Figure 8. The purpose of the pull back device **25** is to permit longitudinal scanning of the lens **2**/beam director **3** of the optical probe/guidewire. This can be accomplished by actuating the pull back mechanism **25** to move one of the guidewire housing **11** and the optical fiber **1** along a longitudinal axis of the optical fiber. Movement is effected by pulling back a mechanical linkage **26** which is coupled to the guidewire housing **11** and the RFOJ **13** as shown in Figure 8. The linkage **26** can be made by several methods as known by those skilled in the art, such as by using linear stepper stages or coil winding technology.

In one embodiment of the invention, the ferules **18** and guidewire housing **11** are mechanically linked using standard techniques for affixing rotary joints as known in the art. In another embodiment of the invention, the optical fiber **1** is pulled back within the housing **11** of the guidewire. In this case, the quick disconnect unit **15** is modified to allow relative longitudinal motion between the single-mode optical fiber **1** and the guidewire housing **11**. In a further embodiment of the invention, where the optical probe/guidewire is part of another insertional medical device, such as a catheter, the entire optical probe/guidewire may be pulled back. This prevents the guidewire from damaging a vessel **17** and allows easy repositioning of the optical probe/guidewire after pull back. Using the pull back option, the optical probe/guidewire/catheter/optical system may be used as a diagnostic catheter, mapping out potential areas of intervention for a cardiologist, for example.

In another embodiment of the invention, the RFOJ **13** is eliminated in favor of a high-speed longitudinal scanning mechanism, such as a galvanometer driven translation mechanism. This

- 22 -

type of scanning mechanism uses a Galvanometer motor coupled to a linear ball-bearing slide which is in turn coupled to the optical fiber **1**. The slide is coupled to the motor using a flexure that translates the rotational motion of the galvanometer into linear translation of the slide and optical fiber **1**. The high-speed scanning mechanism is used to "push-pull" the fiber back and forth at high speed past a transparent section in the probe housing **11** (e.g., a window **24**). Thus, a longitudinal image instead of a circumferential image is obtained. A galvanometer driven translation mechanism may be obtained from commercial sources (e.g., General Scanning, Incorporated, Watertown, Massachusetts).

It should be obvious those of skill in the art that there are other types of connector elements that can be used and these are encompassed within the scope of the invention. For example, in one embodiment of the invention, the quick disconnect unit **15** and the disposable connector **12** are separable elements, while in another embodiment of the invention the quick disconnect unit **15** and disposable connector **12** are part of a single connector device. In the latter embodiment, the output of the RFOJ **13** also has ferules **18** which are the same size as that of the quick disconnect **15** and directly connects to the quick disconnect housing **23** so that the disposable connector **12** and quick disconnect **15** are thereby integrated into one assembly.

A guidewire housing **11** according to one embodiment of the invention is shown in more detail in Figure 10. In this embodiment, the proximal end of the housing **11** mates with the quick disconnect unit **15**. In one embodiment of the invention, the optical fiber **1** is free to spin relative to the housing **11** but is fixed longitudinally so that the quick disconnect ferule **18** and housing **11** cannot be separated. The combination of circumferential scanning from the spinning fiber **1** within the guidewire housing **11**, and longitudinal scanning when the pull back mechanism **25** is used, allows a three-dimensional profile of a vessel **17** to be collected. Using the optical system **16**, an image can be displayed and manipulated to allow the physician/user to view the vessel **17** on the imaging system's display monitor.

The probe housing **11** is fabricated so as to transmit light from the single-mode optical fiber **1** through at least a section of the housing **11** to the sample. Similarly, light retroreflected from the sample also passes through at least a section of the housing **11** back to the single-mode optical fiber **1**. Thus, in a preferred embodiment of the invention, a section of the housing **11** is at least partially transparent.

In one embodiment of the invention where probe housing **11** is in the form of a guidewire, the housing **11** includes an opening **24**, such as a window, which is in optical communication with the lens **2** and beam director **3**. The opening/window **24** is secured in the housing **11** wall

- 23 -

to allow the lens **2**/beam director **3** to image through the guidewire housing **11** and onto the sample (e.g., a blood vessel **17** wall). In a further embodiment of the invention, the beam director **3** is in proximity to a section of the housing **11** which is at least partially transparent, e.g., the opening/window **24**. In another embodiment of the invention, the housing **11** itself is made of plastic or another suitable material that may be transparent to optical radiation. In this embodiment of the invention, no opening or window **24** is needed. In a further embodiment, the housing **11** may comprise a hole (e.g., a slot, a notch, a port, a cutout), or a plurality of holes, through which the beam from the single-mode optical fiber **1** may be directed for scanning of the sample. As defined herein an "opening" may be uncovered and completely open or may be covered by a transparent material.

The design of the opening/window **24** (in Figures 8, 10, and 11A-C) is an important part of the overall optical probe design. The window **24** allows light from an optical fiber **1** to be transmitted through the housing wall **11**. Using standard precision machining and joining technologies, it is possible to incorporate suitable window **24** materials into the housing **11**. Windows **24** that are formed into transparent tubes that exhibit the same or similar outside diameter and shape as the primary housing **11** are greatly preferred since they are easiest to join to the housing **11**. This ensures that the completed assembly does not exhibit any sharp edges or discontinuities, a critical consideration in medical applications. Flat window **24** materials can be used, as discussed above with respect to the metering tubing **9**. While flat window **24** materials make the optical imaging properties of the probe easier to deal with, flat windows cannot be made to accommodate 360 degree scanning and therefore cannot be used when a circumferential scanning guidewire optical probe is desired.

If circular/cylindrical windows **24** are chosen, consideration must be given to the effects of the window **24** material and window **24** shape on the quality of the image that the probe can produce. Standard equations from classical optics give a good insight into the nature of the problems encountered (Figure 13):

$$\frac{n_1}{f_1} = \frac{n_2}{f_2} = \frac{n_2 - n_1}{R_1} - \frac{n_2 - n_3}{R_2} + \frac{(n_2 - n_3)(n_2 - n_1)t}{n_2 R_1 R_2} \quad (9)$$

where  $n_1$  is the medium index to the left of the window **24**,  $n_2$  is the index of the window **24** material itself,  $n_3$  is the index in the medium to the right of the window **24**,  $R_1$  is the inner radius of curvature,  $R_2$  is the outer radius, and  $t$  is the window **24** thickness. It becomes apparent from



- 24 -

examining the above equation that to minimize the effects of the window **24** which could lead to poor image quality (i.e., by driving the focal lengths  $f_1$  and  $f_2$  towards  $\infty$ ), the most important issue is matching the three indices, followed by decreasing the thickness of the window **24** material. Decreasing the thickness of the window **24** material also drives the inner and outer radius of curvature closer, further minimizing the cylindrical focusing effects of a window having a curved surface by increasing the radius of curvatures.

It is understood that the above equation is for a window with a spherical surface, whereas when using the circular/cylindrical windows of the present invention, the effect is only in the direction parallel to the housing **11** axis. However, the above equation serves to illustrate the importance of matching the index of refraction of the window **24** with that of the medium to obtain better image quality.

A flat window **24** (i.e. driving the radii towards  $\infty$ ) will also minimize detrimental effects on imaging. In a further embodiment of the invention, a window **24** section is made in a square or hexagonal form to allow radial scanning of a sample. In this embodiment, as the flat window **24** would still distort the scanning of the beam, a scan correction algorithm is programmed into a processor which is part of the optical system **16**. Thus, circular windows are preferred. Window **24** materials which possess desired qualities (index, material strength, optical transmission, material optical quality, sterilizability, and so forth) include, but are not limited to, fluoropolymers, other plastics, glass, and the like.

In a further embodiment of the invention, a series of small holes are provided in the proximal section of the housing **11** wall to allow the outside sample medium (e.g., water or saline) to fill any interstitial gaps between the lens **2**, beam director **3**, and the inner radius of the window **24**, to further aid in index-matching and to reduce unwanted Fresnel reflections. In a further embodiment of the invention, the space between the lens **2** and the window **24** is filled and sealed with an optical transmitter including a gel, an oil, or other suitable materials, to perform the desired refraction index matching.

Choosing the proper index-matching fluid can be accomplished using the following relationship:

$$\frac{n_2 - n_1}{R_1} = \frac{n_2 - n_3}{R_2} \quad (10)$$

where the parameters are as given above. Here  $n_1$  is the index of the matching fluid or gel,  $n_2$  is the index of the window **24** material, and  $n_3$  is the index of refraction of the surrounding sample medium. Given that the window **24** dimensions and index of refraction are fixed, choosing the

- 25 -

matching material according to the above relationship will effectively neutralize the optical effects of the window 24 to first order.

In a one embodiment of the invention, the index-matching material is placed in the optical probe/guidewire just prior to patient use. Gaussian beam modeling, as previously described, can be employed to more accurately assess the effect of a curved window 24 on image quality, allowing engineering design decisions to be made when choosing materials and shapes. Finally, it is possible to eliminate any window altogether by simply providing a series of slots or holes in the housing 11 wall. In this embodiment, the larger the fraction of holes in the housing 11 wall (e.g., a hypotube), the larger the fraction scan area. The number of holes in the housing 11 is optimized to maximize image quality while maintaining structural integrity.

The probe housing 11 may further comprise elements found in standard guidewires. In one embodiment (Figure 10), a spring 25 is affixed to the opening/window 24 of the guidewire housing 11. The spring 25 allows the optical probe/guidewire flexibility in navigating tortuous pathways in the body. The spring 25 is configured so as not to cover at least a section of the housing 11 which includes the opening/window 24. In a further embodiment of the invention (Figures 11A-C), the opening 24 comprises a clear section of hypotube and two sets of springs 25 are provided; each set stopping short of the opening 24/hypotube. In one embodiment, a flat safety ribbon is used to ensure that both ends of the spring coil 25 remain attached. In another embodiment of the invention, the spring 25 can be continually wound to be one unit. The opening 24/hypotube is affixed to both ends of the spring with an adhesive or by mechanical means. Safety ribbons can also be used. In another embodiment of the invention, the spring 25 includes a radio-opaque tip 28. In a further embodiment of the invention, the entire spring 25 comprises radio-opaque material. By providing a radio-opaque tip 28 or radio-opaque material, the passage of the optical probe/guidewire through a lumen is easily visualized using an angiography monitor, for example.

In another embodiment of the invention, a mechanism to flush sample medium (e.g., blood) from the optical probe/guidewire is provided in order to improve the penetration depth of the image. In one embodiment of the invention, flushing is done automatically using the optical system 16 (e.g., an OCT system) or manually, using standard flushing catheters passed over, or adjacent to, the guidewire housing 11.

Although a guidewire is shown and discussed in Figures 8-11A-C, it is clear that the lens 2 technology and scanning mechanisms described with respect to the Figures can be used for a

- 26 -

wide range of other medical (and non-medical) probes such as miniature catheters, endoscopes, bronchoscopes, needles, and trocars.

Having thus described certain embodiments of the present invention, various alterations, modifications, and improvements will be apparent to those skilled in the art. Such variations, 5 modifications and improvements are intended to be within the spirit and scope of the invention. Accordingly, the foregoing description is by way of example only and is not intended to be limiting.

What is claimed is:

- 27 -

**CLAIMS**

- 1 1. An optical imaging probe, comprising a single-mode optical fiber optically coupled to a  
2 lens, wherein the lens is substantially the same diameter as the optical fiber.
- 1 2. The optical imaging probe of claim 1, further comprising a coreless fiber optically  
2 coupled to the single-mode fiber and the lens.
- 1 3. The optical imaging probe of claim 1, wherein the lens is in optical communication with  
2 a beam director.
- 1 4. The optical imaging probe of claim 3, wherein the beam director is a fold mirror.
- 1 5. The optical imaging probe of claim 1, wherein the lens comprises a graded index  
2 material.
- 1 6. The optical imaging probe of claim 5, wherein the lens is in optical communication with  
2 an optical transmitter having a substantially uniform refractive index.
- 1 7. The optical imaging probe of claim 5, wherein the lens has a substantially flat facet.
- 1 8. The optical imaging probe of claim 5, wherein the lens comprises an angled facet.
- 1 9. The optical probe of claim 1, further comprising a fold mirror in optical communication  
2 with the lens.
- 1 10. The optical probe of claim 9, wherein the fold mirror is in physical contact with the lens.
- 1 11. The optical probe of claim 9, wherein the fold mirror is spaced apart from the lens.
- 1 12. The optical probe of any of claims 9-12, wherein the fold mirror comprises a dichroic  
2 coating.
- 1 13. The optical probe of claim 3, wherein the beam director is a prism.
- 1 14. The optical probe of claim 1, wherein the optical fiber is at least partially contained  
2 within a probe housing.
- 1 15. The optical probe of claim 14, wherein the optical fiber is rotatable within the probe  
2 housing.
- 1 16. The optical probe of claim 14, wherein the probe housing is in the form of an insertional  
2 medical device.
- 1 17. The optical probe of claim 14, wherein the insertional medical device comprises any of a  
2 guidewire, an endoscope, a bronchoscope, a catheter, a needle, and a trocar.
- 1 18. The optical probe of claim 17, wherein the insertional medical device is a guidewire.
- 1 19. The optical probe of claim 14, wherein a section of the probe housing is at least partially  
2 transparent.
- 1 20. The optical probe of claim 14, wherein the probe housing comprises a window.

- 28 -

- 1 21. The optical probe of claim 20, further comprising a beam director positioned so as to  
2 direct and receive a light beam through the window.
- 1 22. The optical probe of claim 14, further comprising a connector having a first end for  
2 coupling to the probe housing and a second end for coupling to an optical system.
- 1 23. The optical probe of claim 22, wherein the probe housing is in the form of a guidewire  
2 and the first end of the connector has a diameter which is substantially the same size as  
3 the diameter of the guidewire.
- 1 24. The optical probe of claim 22, further comprising a rotating fiber optic joint for rotatably  
2 coupling the optical fiber to the optical system.
- 1 25. The optical probe of claim 14, further comprising a pull back mechanism in  
2 communication with one of the housing and the optical fiber, wherein actuation of the  
3 pull back mechanism causes linear motion of at least one of the probe housing and the  
4 optical fiber relative to a longitudinal axis of the optical fiber.
- 1 26. The optical probe of claim 19 or 20, wherein the section of the housing which is at least  
2 partially transparent has substantially the same refractive index as the medium in which  
3 the housing is immersed.
- 1 27. The optical probe of claim 28, wherein the space in said probe housing comprises any of  
2 a fluid, a gel, and an oil.
- 1 28. The optical probe of claim 1, wherein the working distance of the lens is  $>1$  mm.
- 1 29. The optical probe of claim 1, wherein the depth of field of the lens is  $> 1$ mm.
- 1 30. The optical probe of claim 18, further comprising a spring surrounding the housing.
- 1 31. The optical probe of claim 30, wherein the spring comprises a radio-opaque marker.
- 1 32. The optical probe of claim 14, wherein the walls of the probe housing define a hole.
- 1 33. A method of measuring the optical properties of a test sample *in situ*, comprising:  
2 positioning an optical probe in proximity to the sample, the optical probe  
3 comprising a substantially single-mode optical fiber optically coupled to a lens, the lens  
4 having substantially the same diameter as the optical fiber;  
5 transmitting an optical beam from the optical probe to a sample *in situ*; and  
6 detecting light transmitted from the sample.
- 1 34. The method of claim 33, wherein the method further comprises the step of comparing the  
2 optical properties of the test sample to optical properties of a control sample.
- 1 35. A method of making a microlens, comprising:  
2 providing a graded index fiber;

- 29 -

3 splicing the graded index fiber to a coreless fiber;  
4 precision cleaving the coreless fiber to a predetermined distance;  
5 splicing the coreless fiber to a single-mode fiber; and  
6 precision cleaving the graded index fiber to a distance selected to provide a  
7 microlens with desired optical properties.

Gaussian Beam Propagation

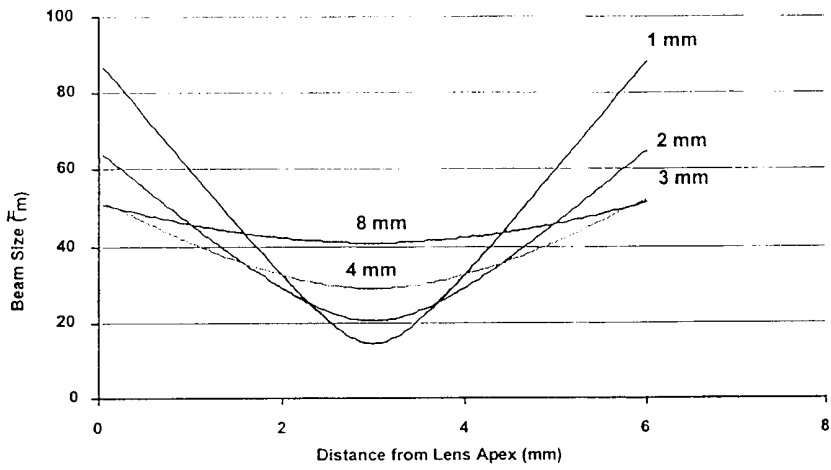
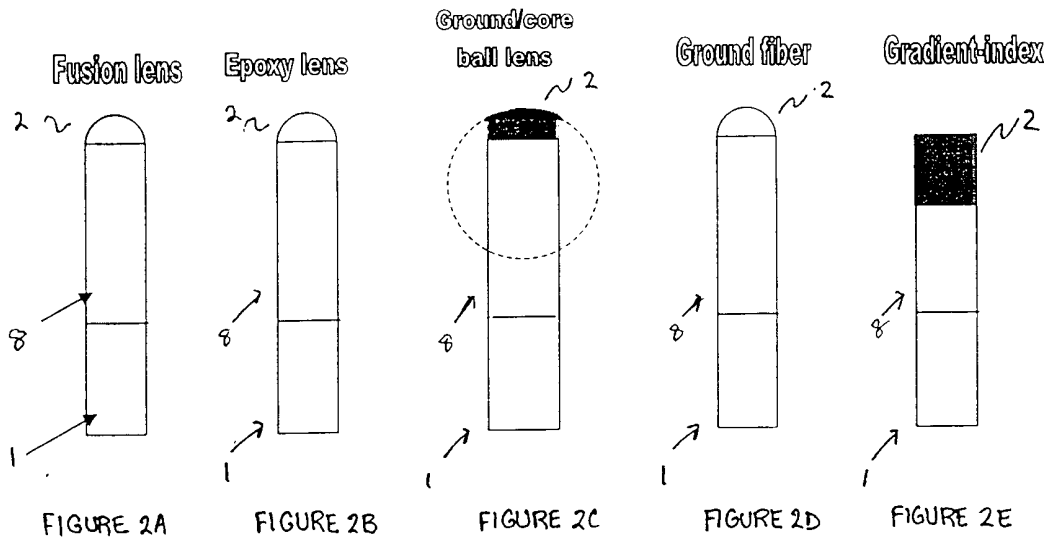

FIGURE 1





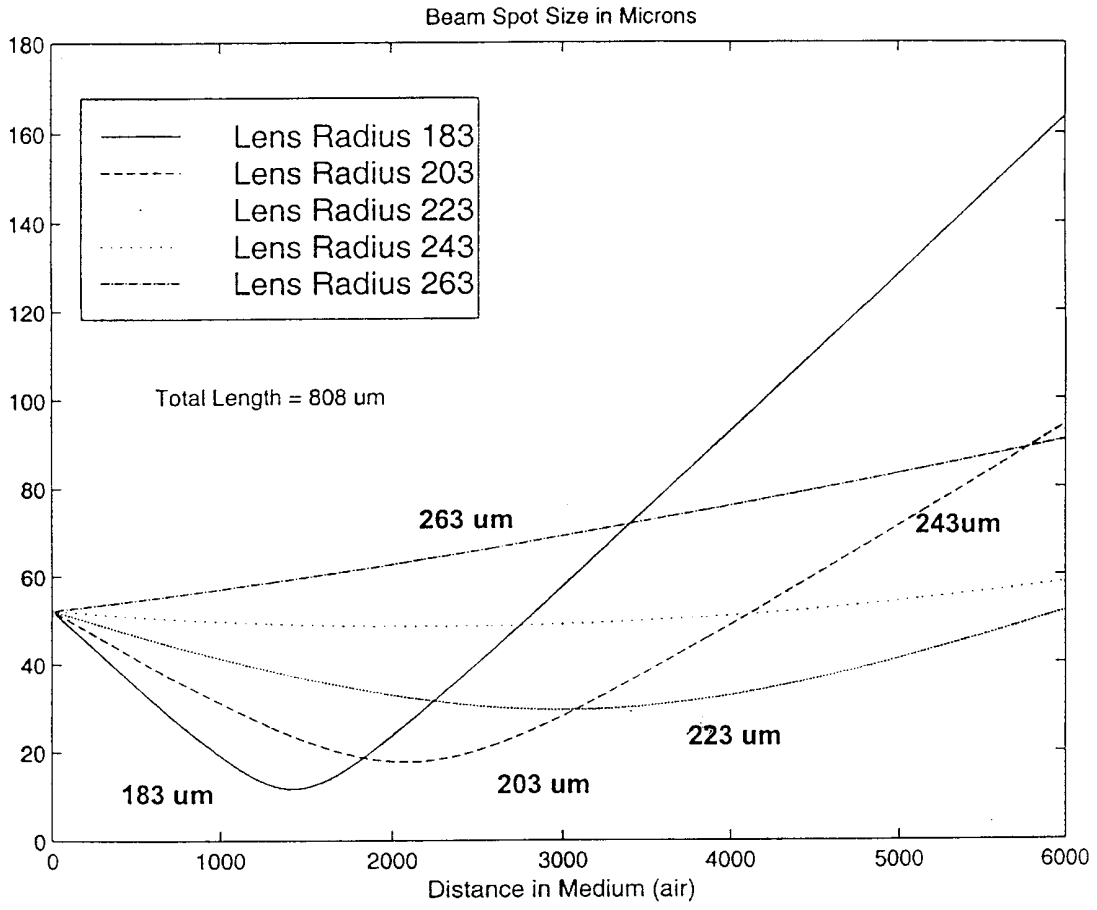

FIGURE 3

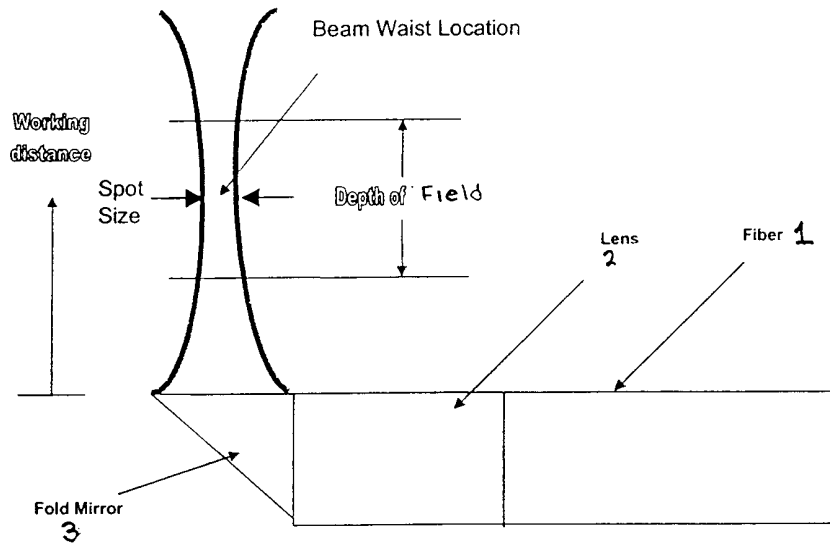

FIGURE 4

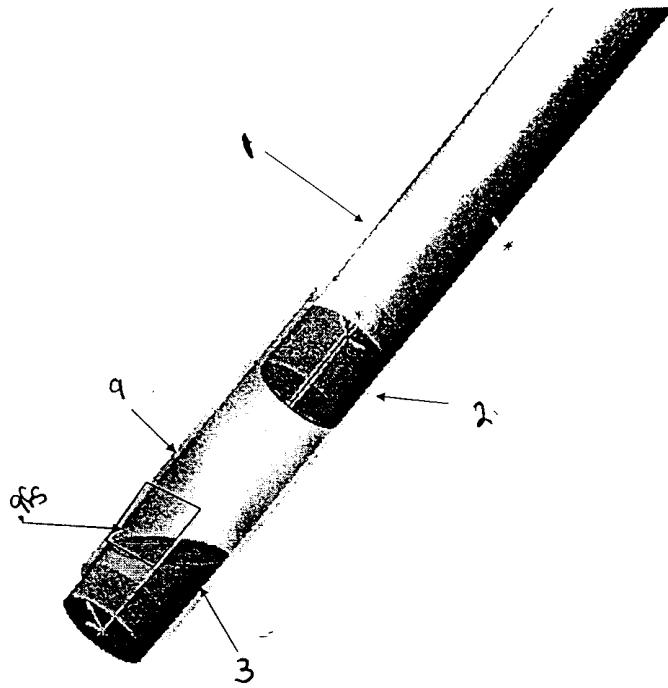

FIGURE 5

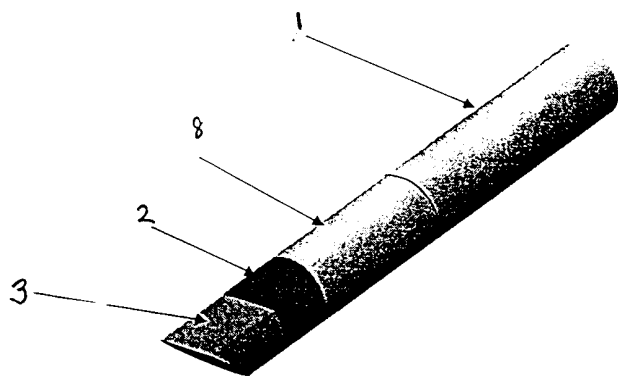

FIGURE 6

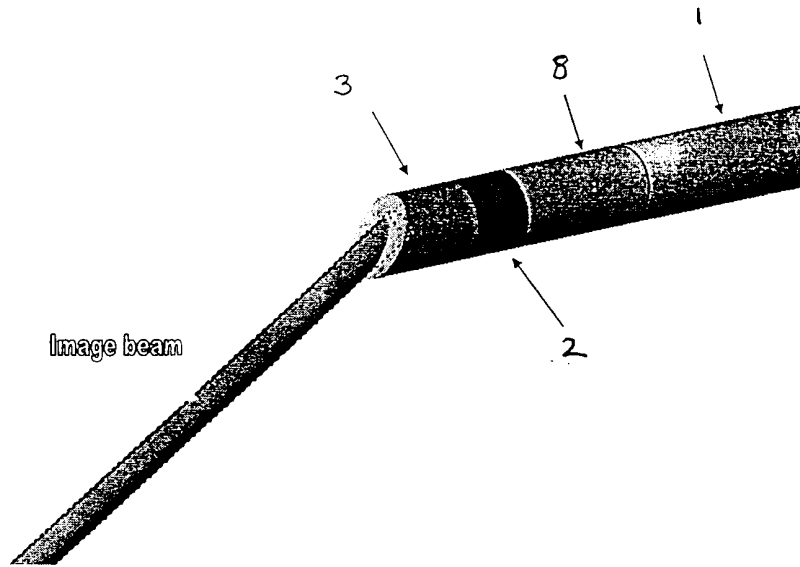

FIGURE 7

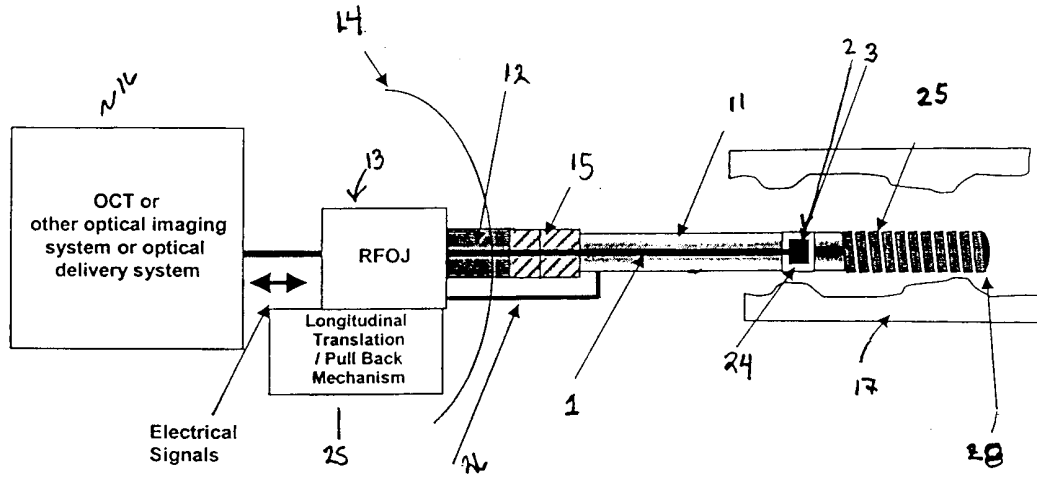

FIGURE 8

FIGURE 9B

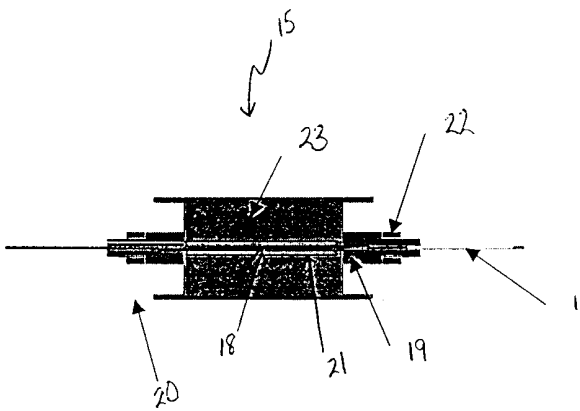

FIGURE 9A

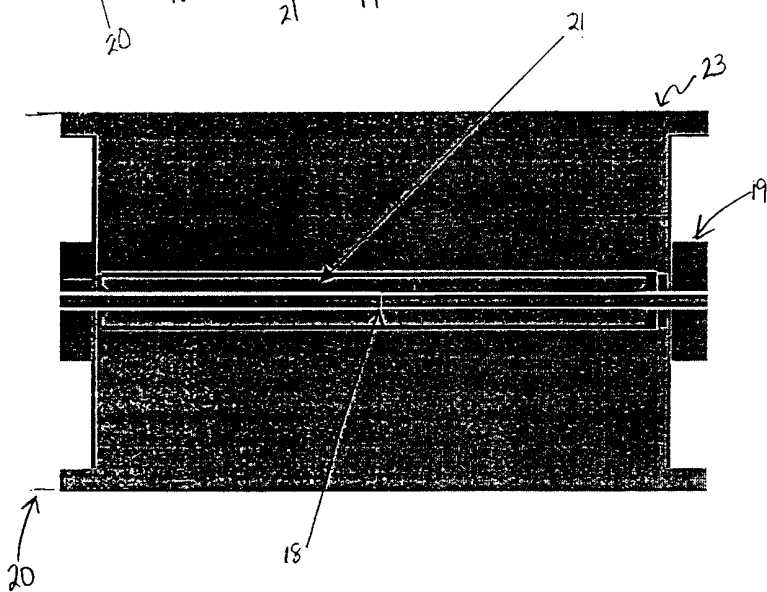

FIGURE 9C

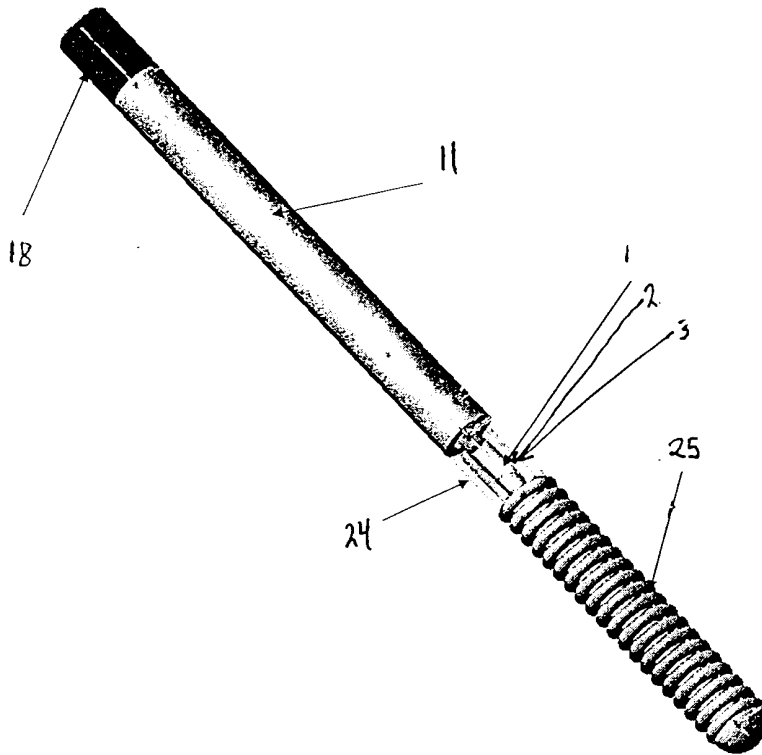

FIGURE 10



FIGURE 11 A

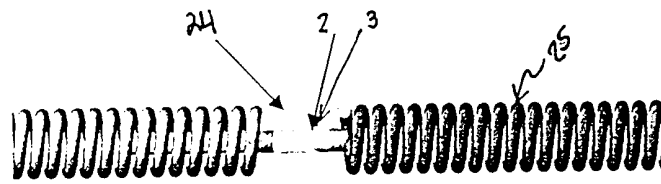

FIGURE 11 B

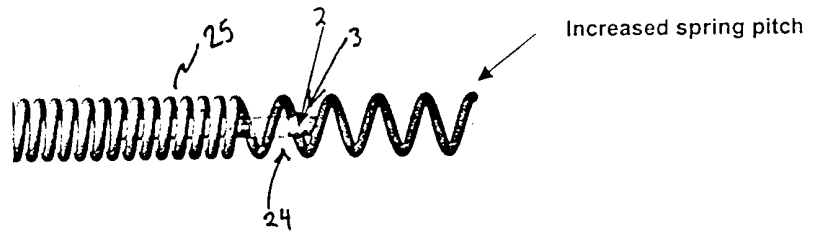
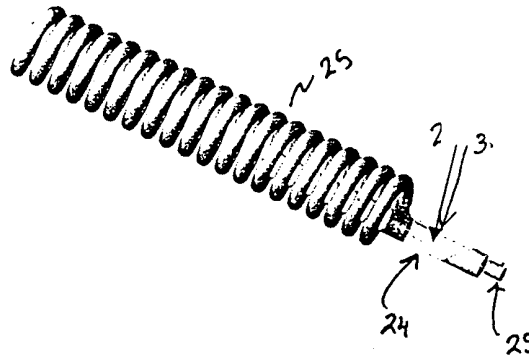

FIGURE 11 C



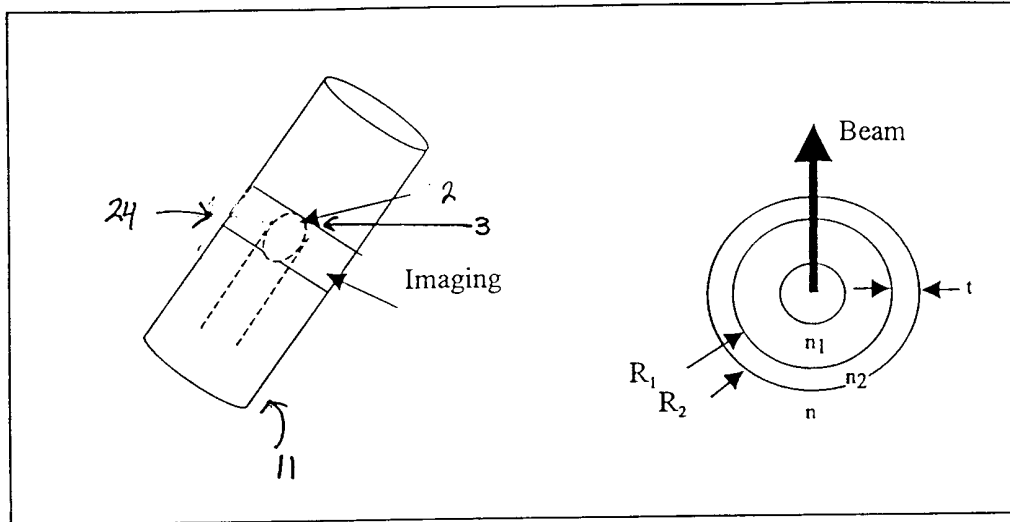

FIGURE 12