



US006993801B2

(12) **United States Patent**  
Marko et al.

(10) **Patent No.:** US 6,993,801 B2  
(45) **Date of Patent:** Feb. 7, 2006

(54) **VARIABLE RAMP ASSEMBLIES AND SYSTEM THEREFOR**

(75) Inventors: **Neil L. Marko**, Hillsdale, MI (US);  
**Charles A. Heitmeyer**, Napoleon, OH (US)

(73) Assignee: **Land Wave Products, Inc.**, Pioneer, OH (US)

(\* ) Notice: Subject to any disclaimer, the term of this patent is extended or adjusted under 35 U.S.C. 154(b) by 168 days.

(21) Appl. No.: **10/613,168**

(22) Filed: **Jul. 3, 2003**

(65) **Prior Publication Data**

US 2005/0000042 A1 Jan. 6, 2005

(51) **Int. Cl.**  
**E04F 11/00** (2006.01)

(52) **U.S. Cl.** ..... **14/69.5**

(58) **Field of Classification Search** ..... 14/69.5,  
14/71.1; 104/275; 254/88

See application file for complete search history.

(56) **References Cited**

**U.S. PATENT DOCUMENTS**

2,450,648 A	*	10/1948	Felzer	254/88
3,970,300 A		7/1976	von Wendt et al.	
4,129,916 A		12/1978	Schlesinger et al.	
4,285,514 A		8/1981	Romero	
4,484,739 A		11/1984	Kreinbuhl et al.	
4,712,264 A		12/1987	Voith	
4,817,224 A	*	4/1989	Visnaw et al.	14/69.5
4,900,217 A		2/1990	Nelson	
5,066,000 A		11/1991	Dolan	
5,137,497 A		8/1992	Dubeta	
5,214,817 A		6/1993	Allen	
5,277,436 A		1/1994	Frank et al.	
5,341,533 A	*	8/1994	Seitz	14/69.5

5,347,672 A		9/1994	Everard et al.	
5,440,773 A		8/1995	Lentini	
5,446,937 A		9/1995	Haskins	
5,509,244 A		4/1996	Bentzon	
5,524,310 A		6/1996	Farnen	
5,566,622 A	*	10/1996	Ziaylek et al.	104/275
5,599,235 A		2/1997	Lynberg	
5,673,517 A	*	10/1997	Stanclift	49/468
5,688,078 A	*	11/1997	Hammer	405/286
5,718,412 A		2/1998	Levanas	
5,740,575 A		4/1998	Gordon	
5,749,615 A		5/1998	Itson	
5,765,707 A	*	6/1998	Kenevan	220/4.28
5,777,266 A	*	7/1998	Herman et al.	174/68.1
5,855,076 A	*	1/1999	Warner et al.	33/562
5,860,867 A		1/1999	Deusen	
5,897,438 A		4/1999	Kunz et al.	
5,946,756 A		9/1999	Mapp	
6,042,480 A		3/2000	Labelson	

(Continued)

**FOREIGN PATENT DOCUMENTS**

GB	2240801 A	*	8/1991
WO	200102667 A	*	1/2001

*Primary Examiner*—Robert E. Pezzuto

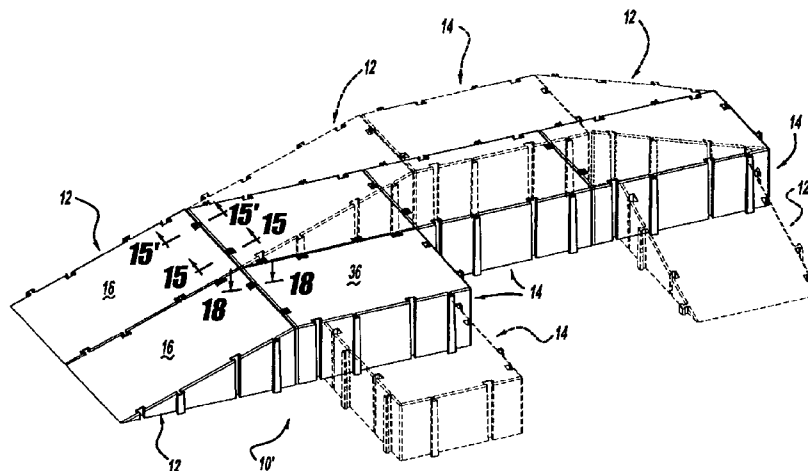
*Assistant Examiner*—Alexandra K. Pechhold

(74) *Attorney, Agent, or Firm*—Harness, Dickey & Pierce, P.L.C.

(57) **ABSTRACT**

A variable stackable ramp system for forming ramp assemblies for providing challenging obstacle courses including ones for aerial lift for sport jumping with skateboards, inline skates, bicycles and the like. The ramp system includes ramp modules of at least two different configurations with one being an inclined ramp module having an inclined upper riding or support surface and a straight ramp module having a generally horizontal straight upper riding or support surface. The ramp modules are adapted to be interconnected horizontally and vertically in a variety of orientations to provide ramp assemblies of selectively different overall configurations.

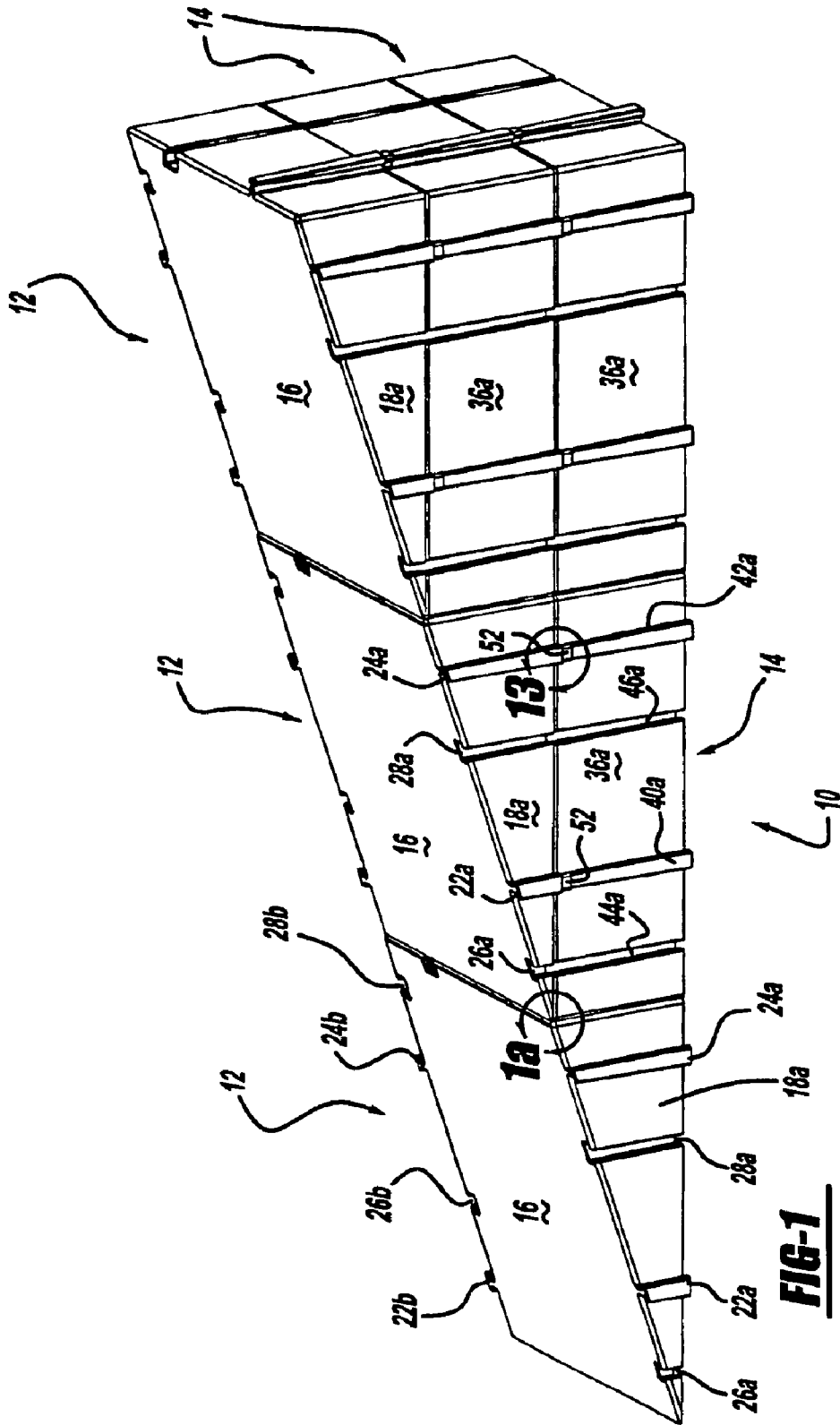
**47 Claims, 15 Drawing Sheets**



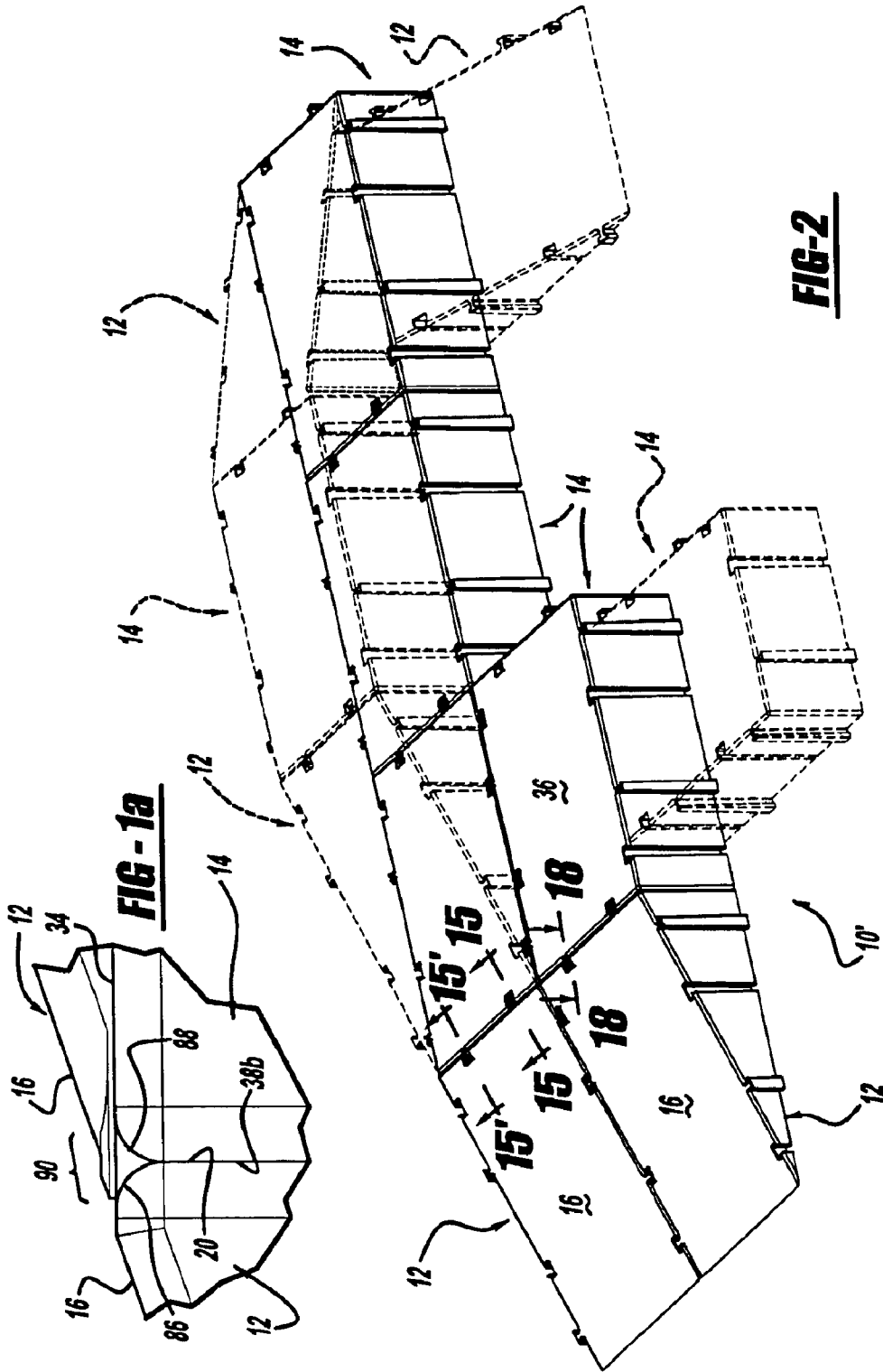
U.S. PATENT DOCUMENTS

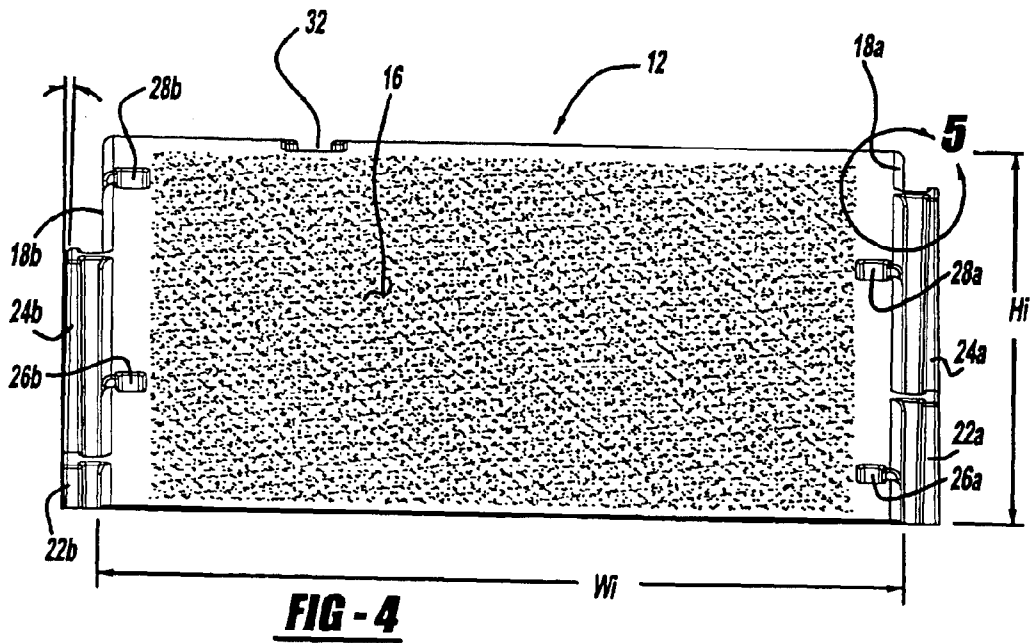
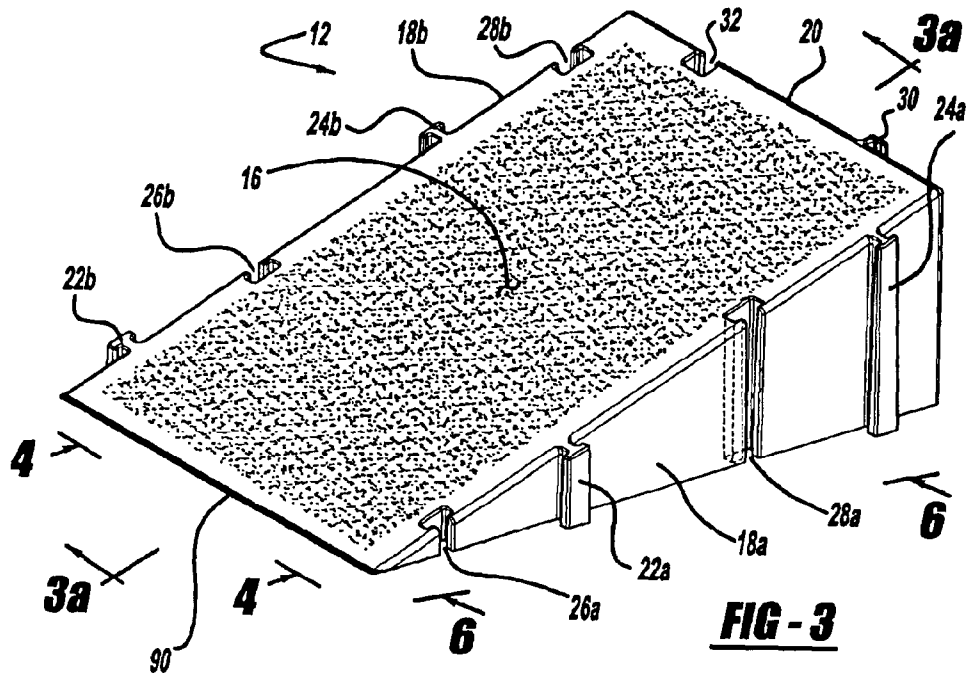
6,439,543	B1	*	8/2002	Peckham .....	254/88	6,695,707	B1	2/2004	Fernandez	
6,463,613	B1		10/2002	Thompson		6,715,177	B1	4/2004	Lagergren-Julander	
6,481,036	B1	*	11/2002	Duvall .....	14/69.5	6,745,422	B1	6/2004	Emerson, Jr.	
6,654,977	B1		12/2003	Chin		6,782,577	B2	8/2004	Rieber et al.	
6,672,968	B2		1/2004	Montolio .....	472/89	2002/0124332	A1	* 9/2002	Janowak .....	14/69.5
6,676,529	B2		1/2004	Pernal .....	472/89					

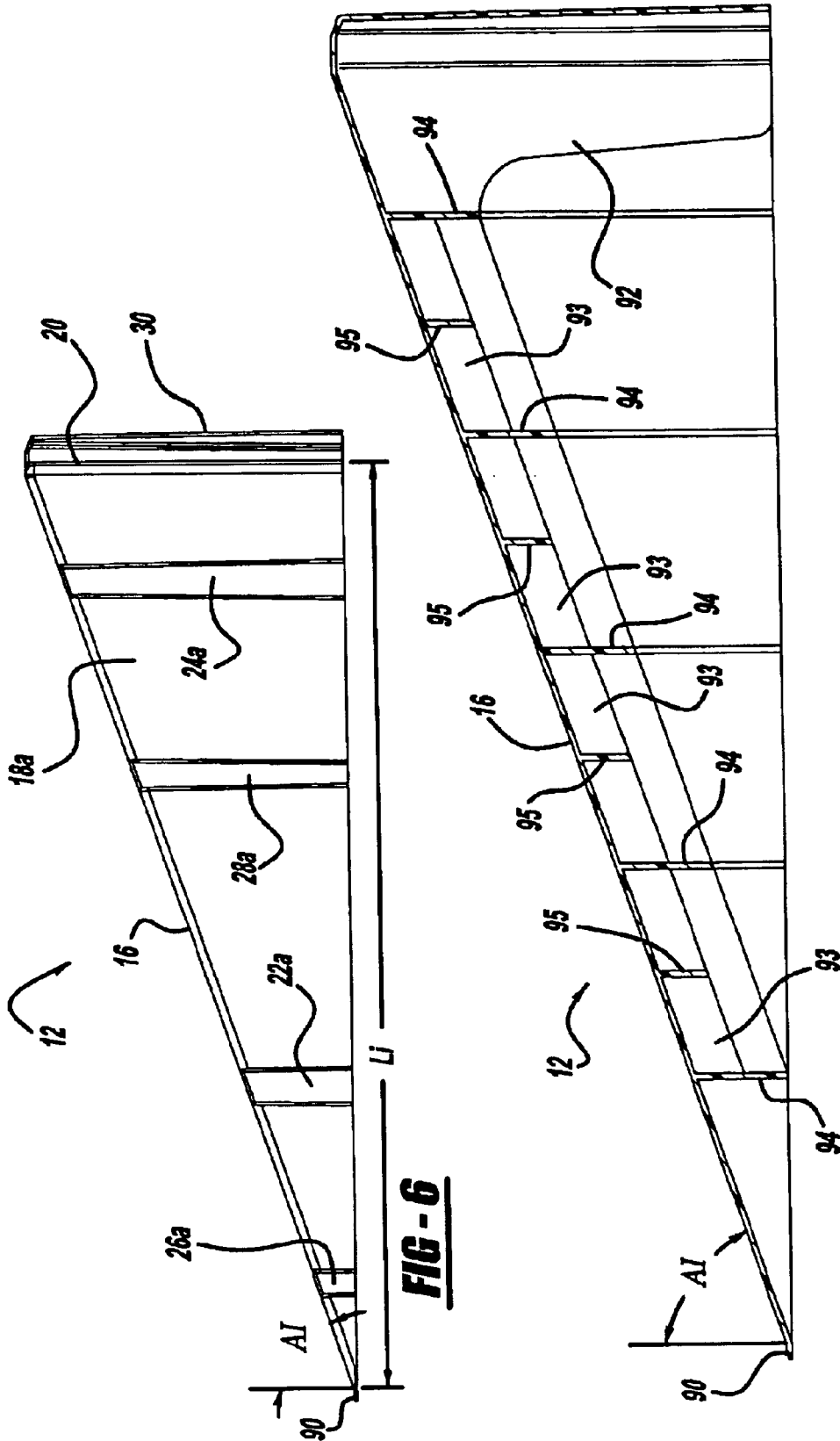
\* cited by examiner

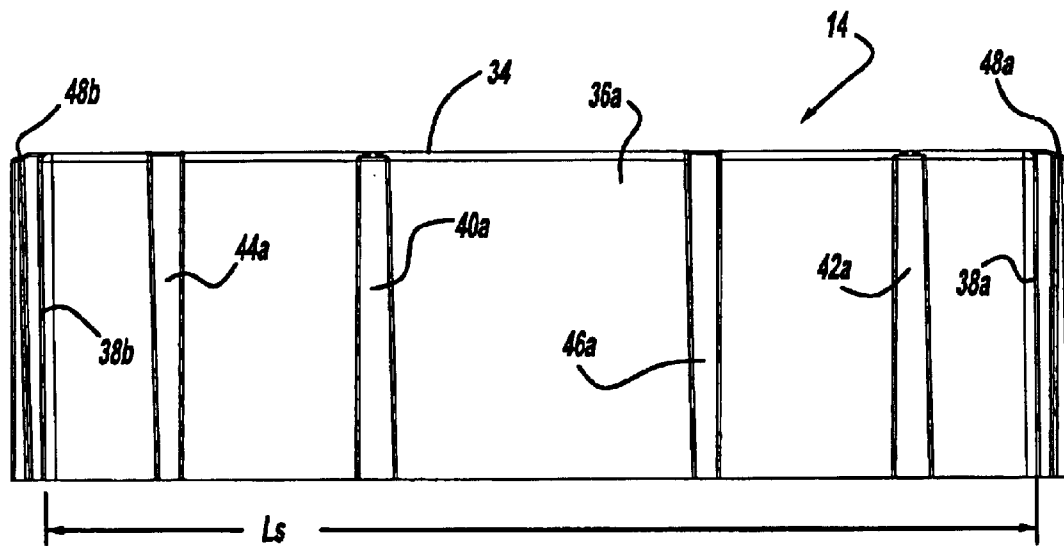
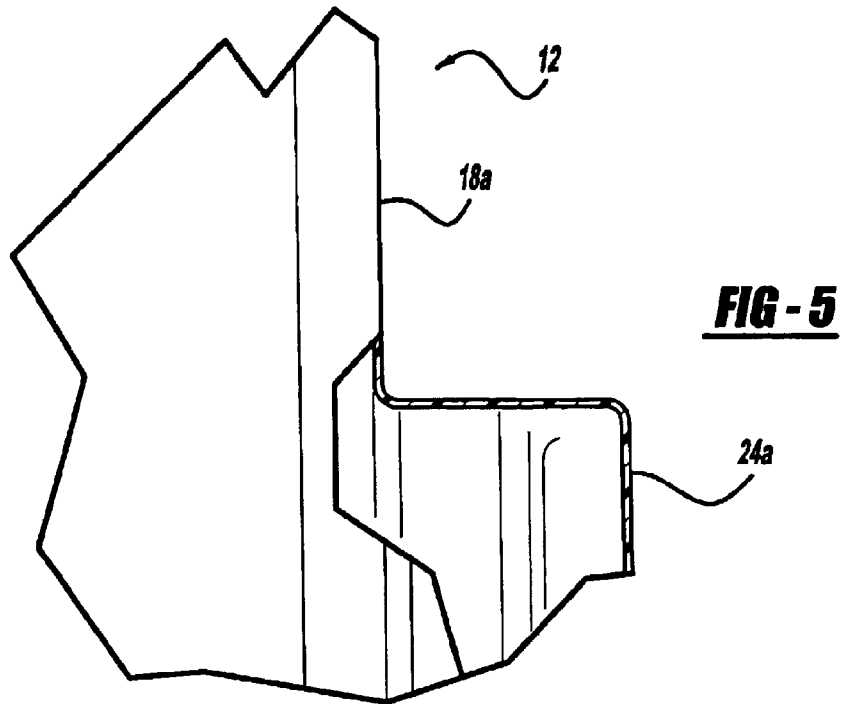


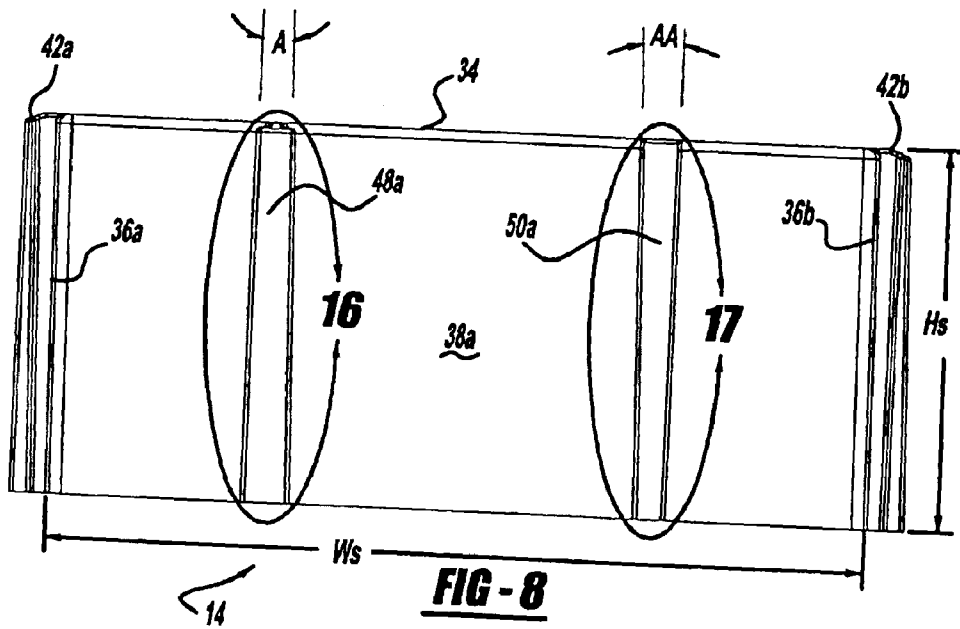
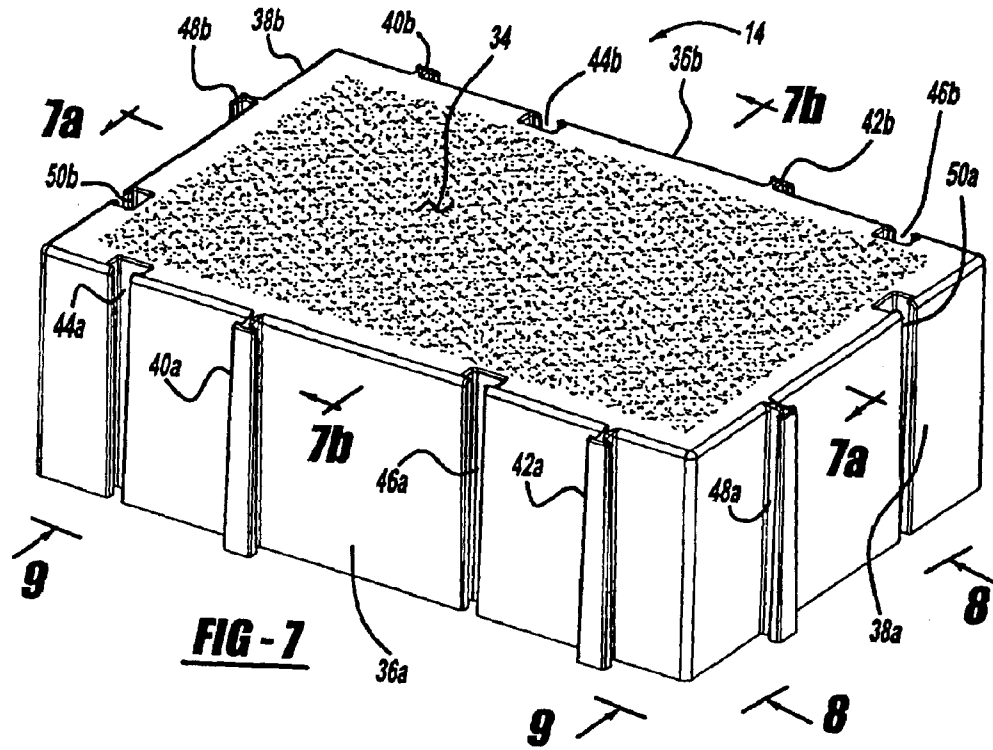
**FIG-1**



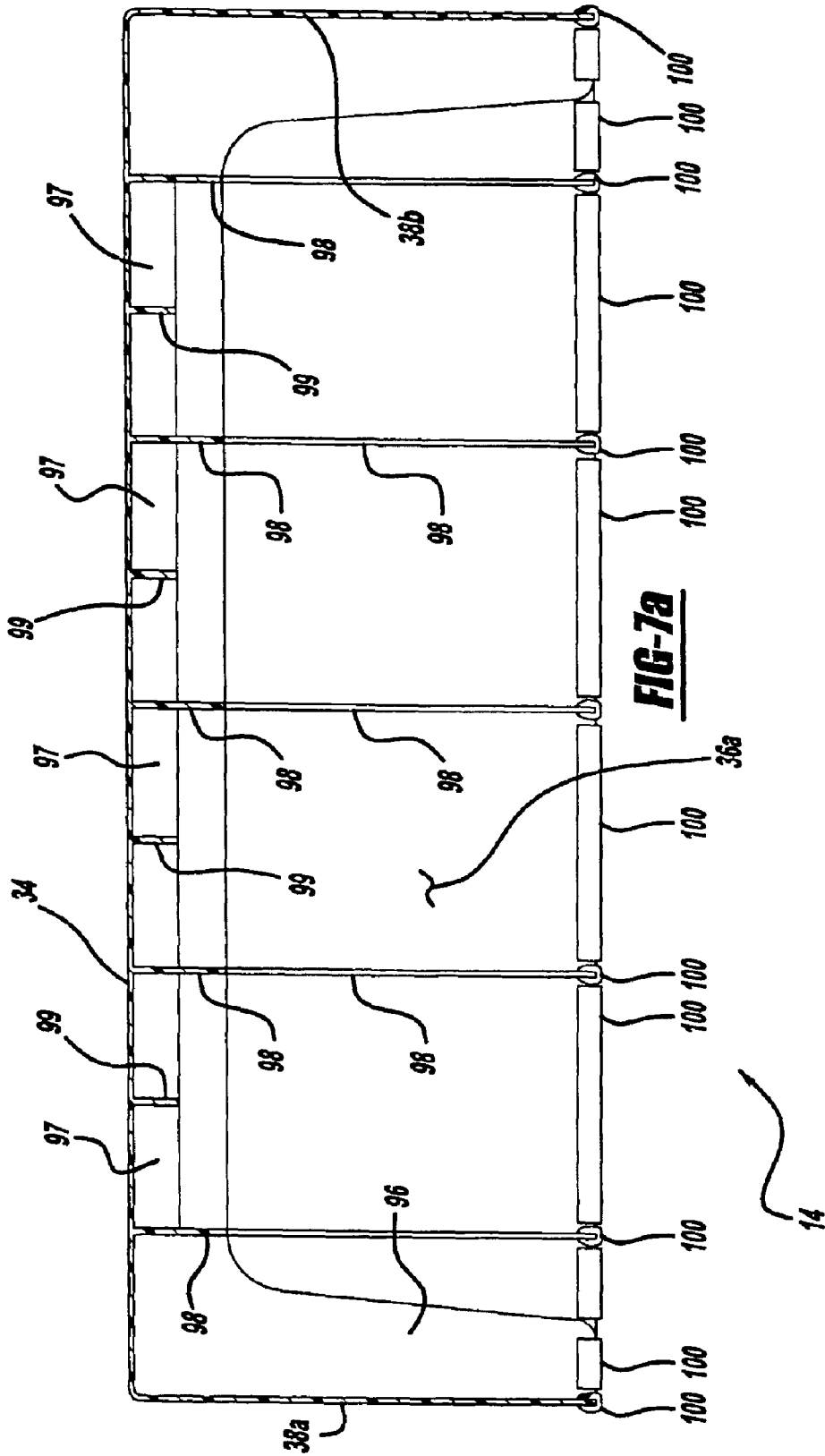




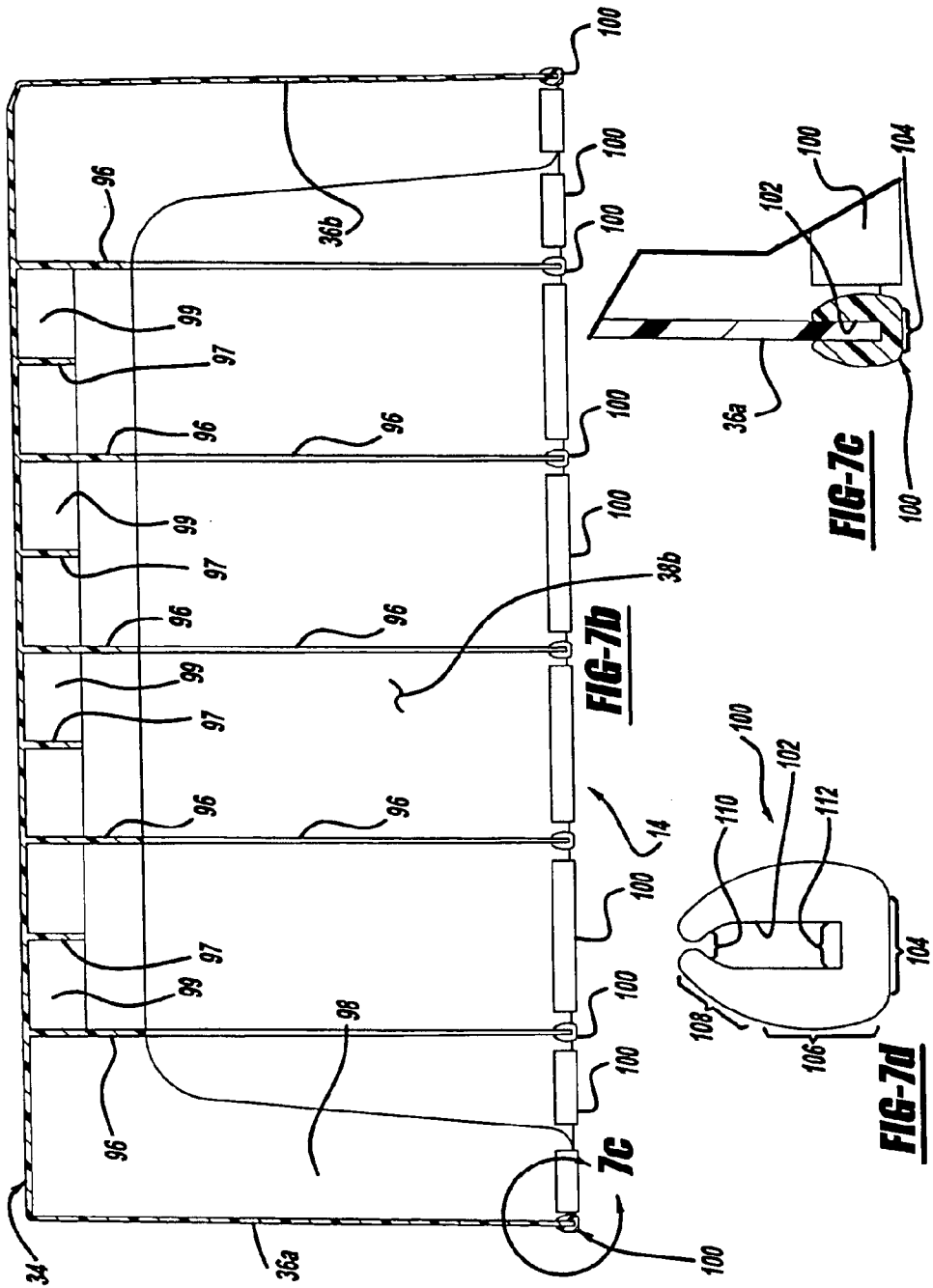


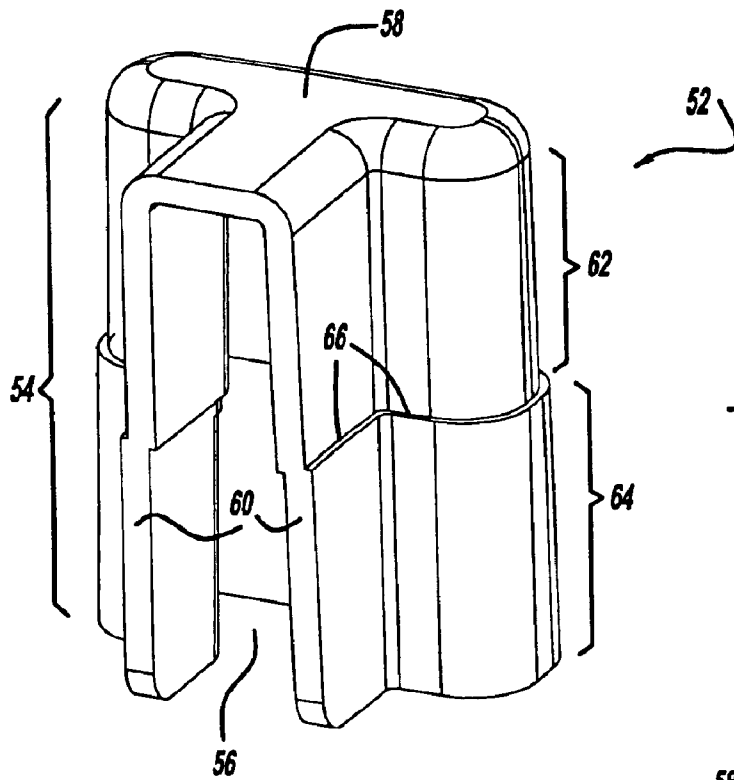




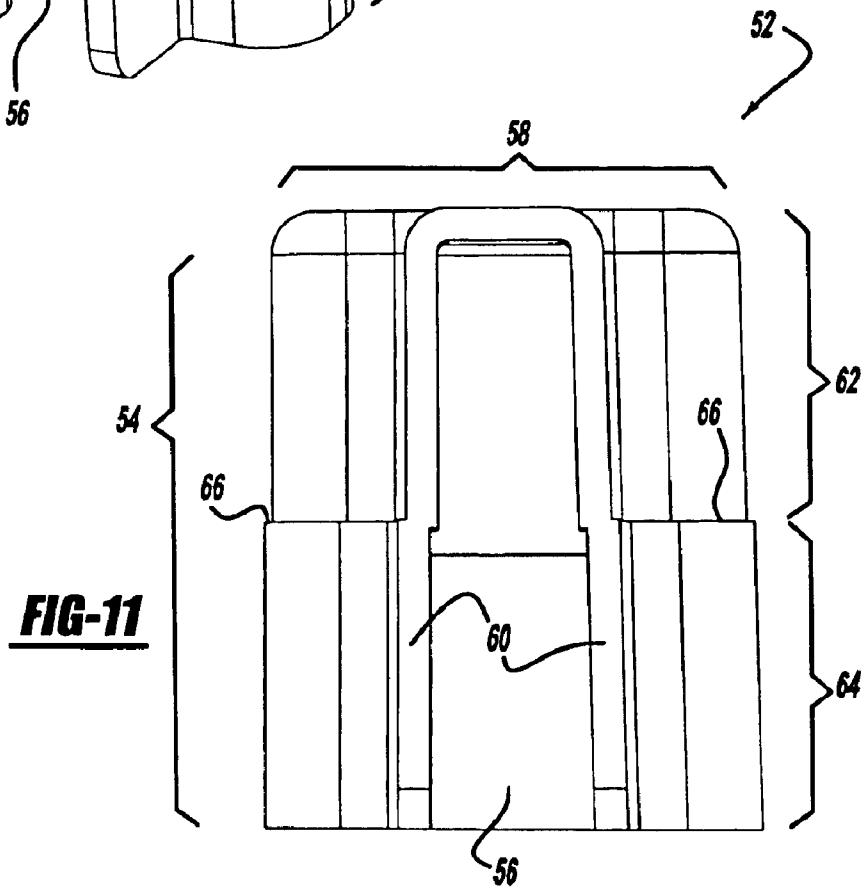


**FIG-7a**

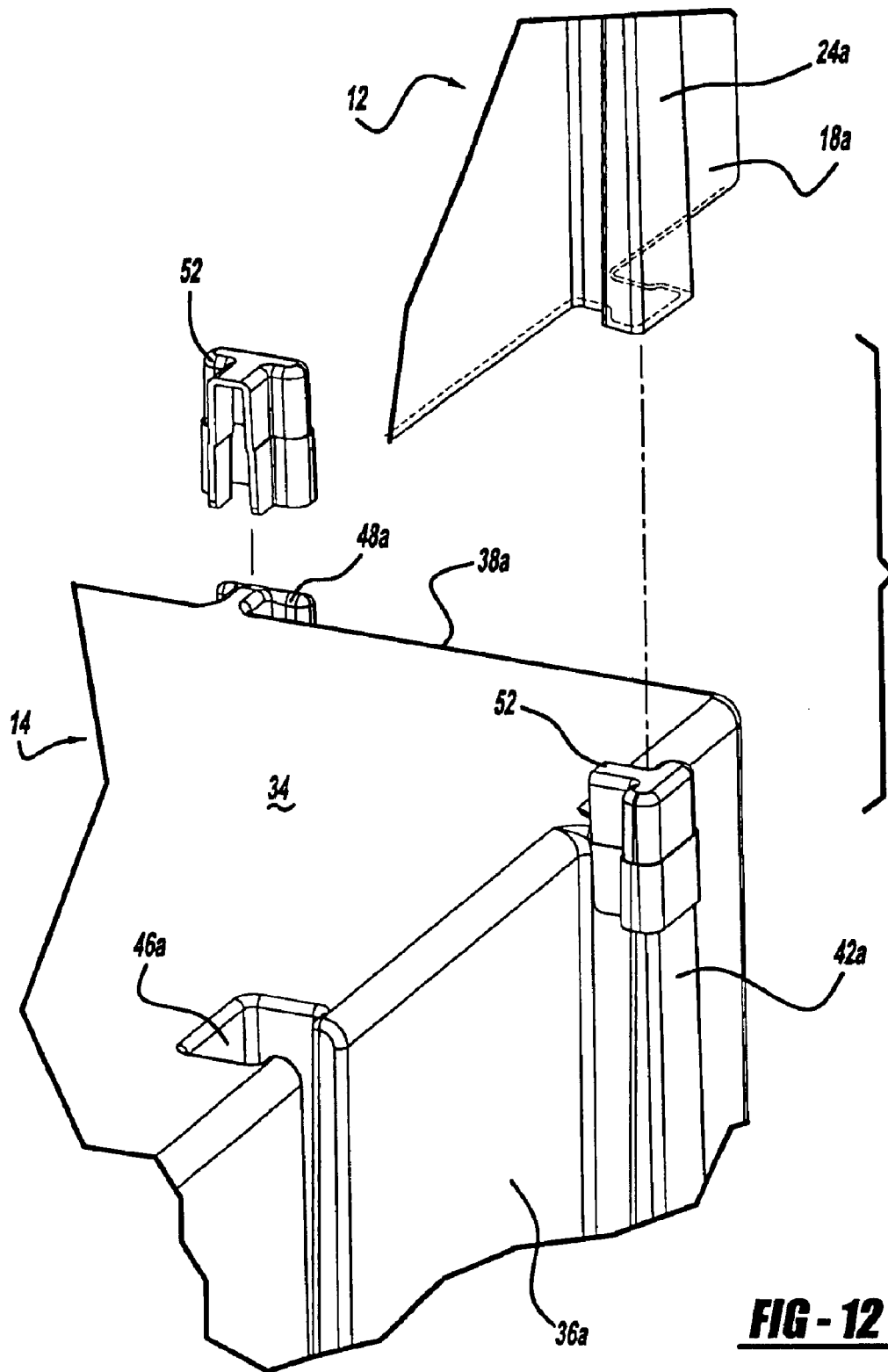




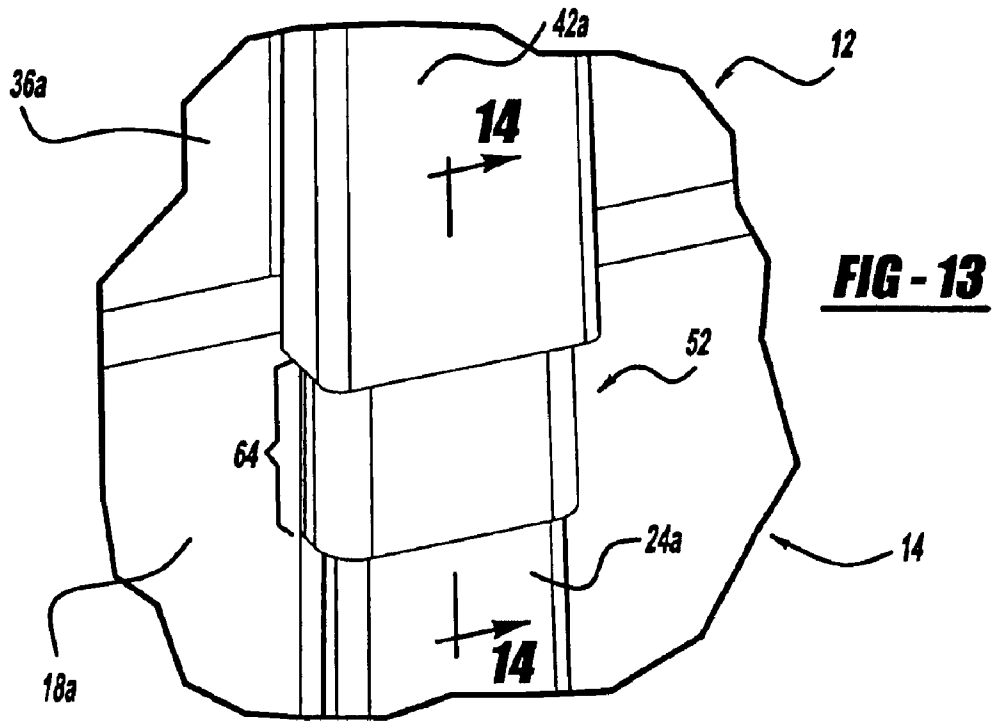
**FIG-10**



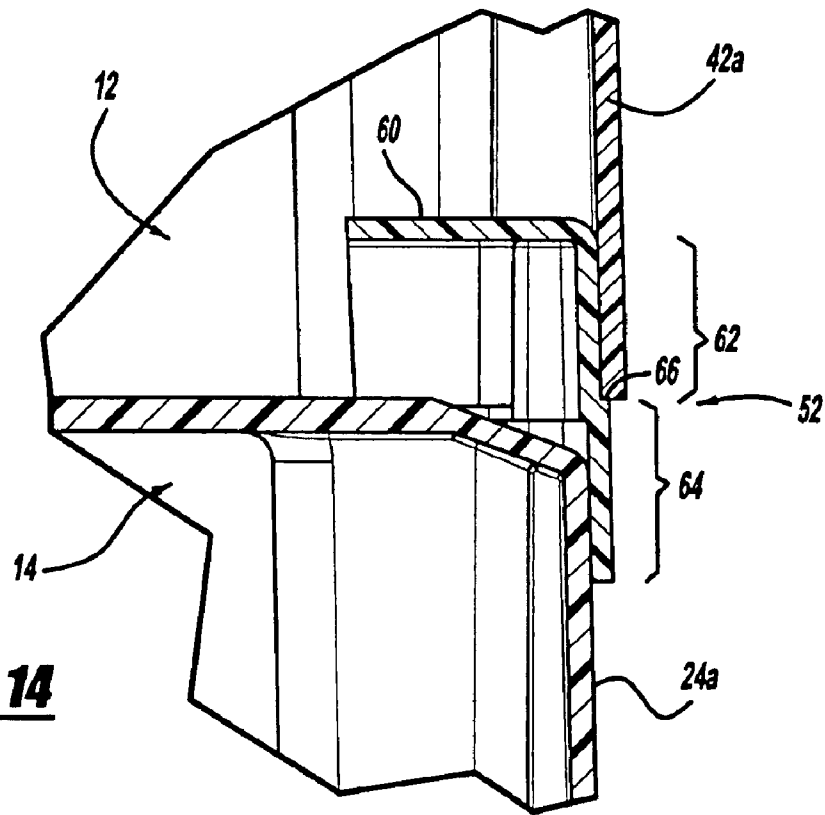
**FIG-11**



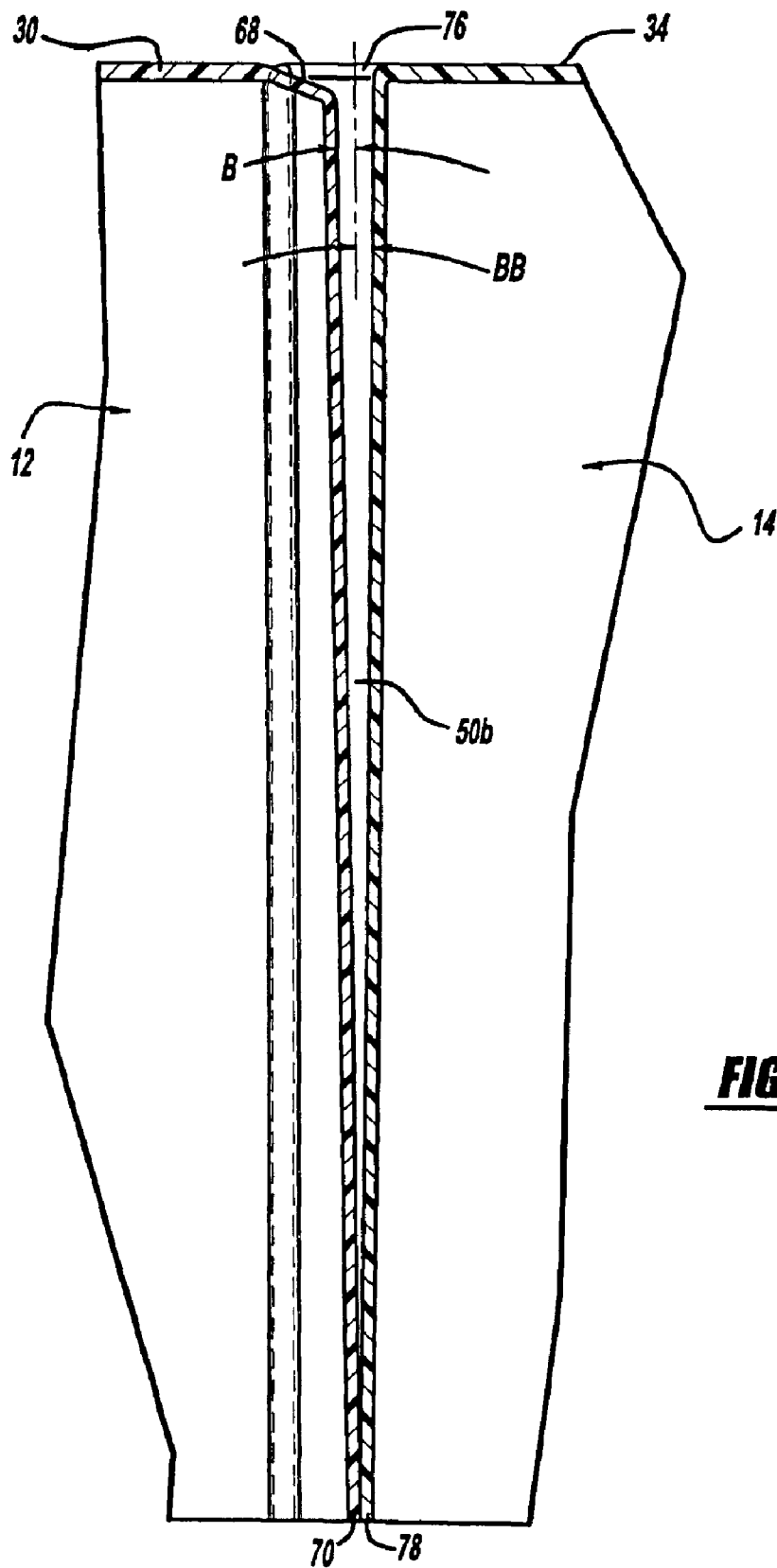
**FIG - 12**



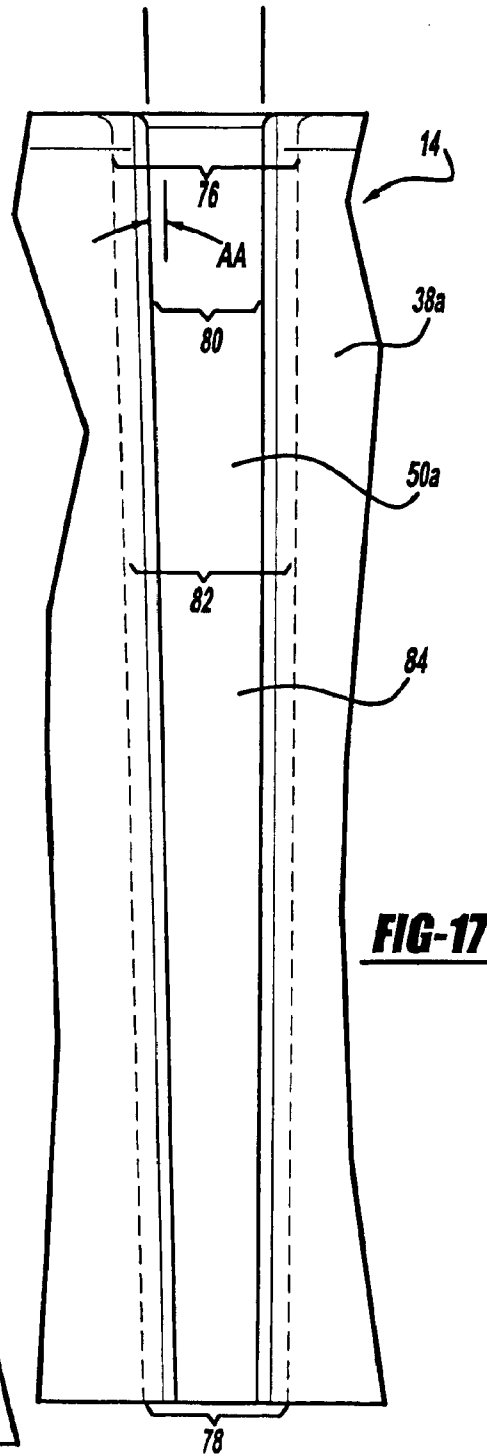
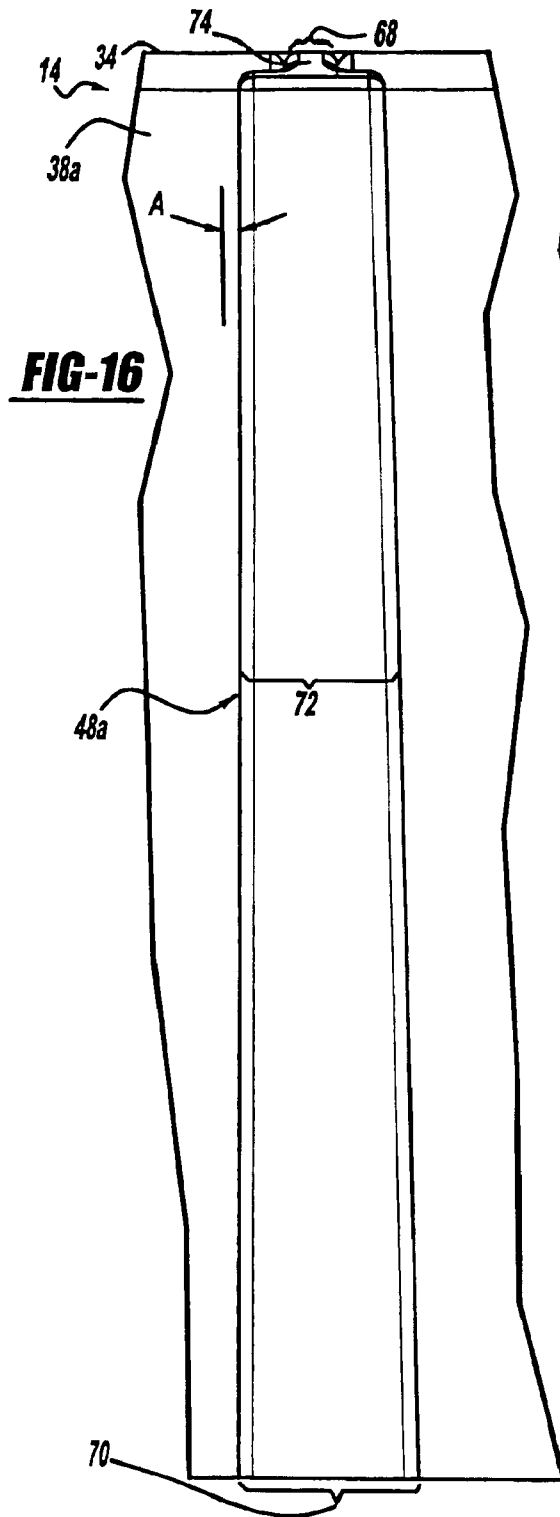
**FIG - 13**

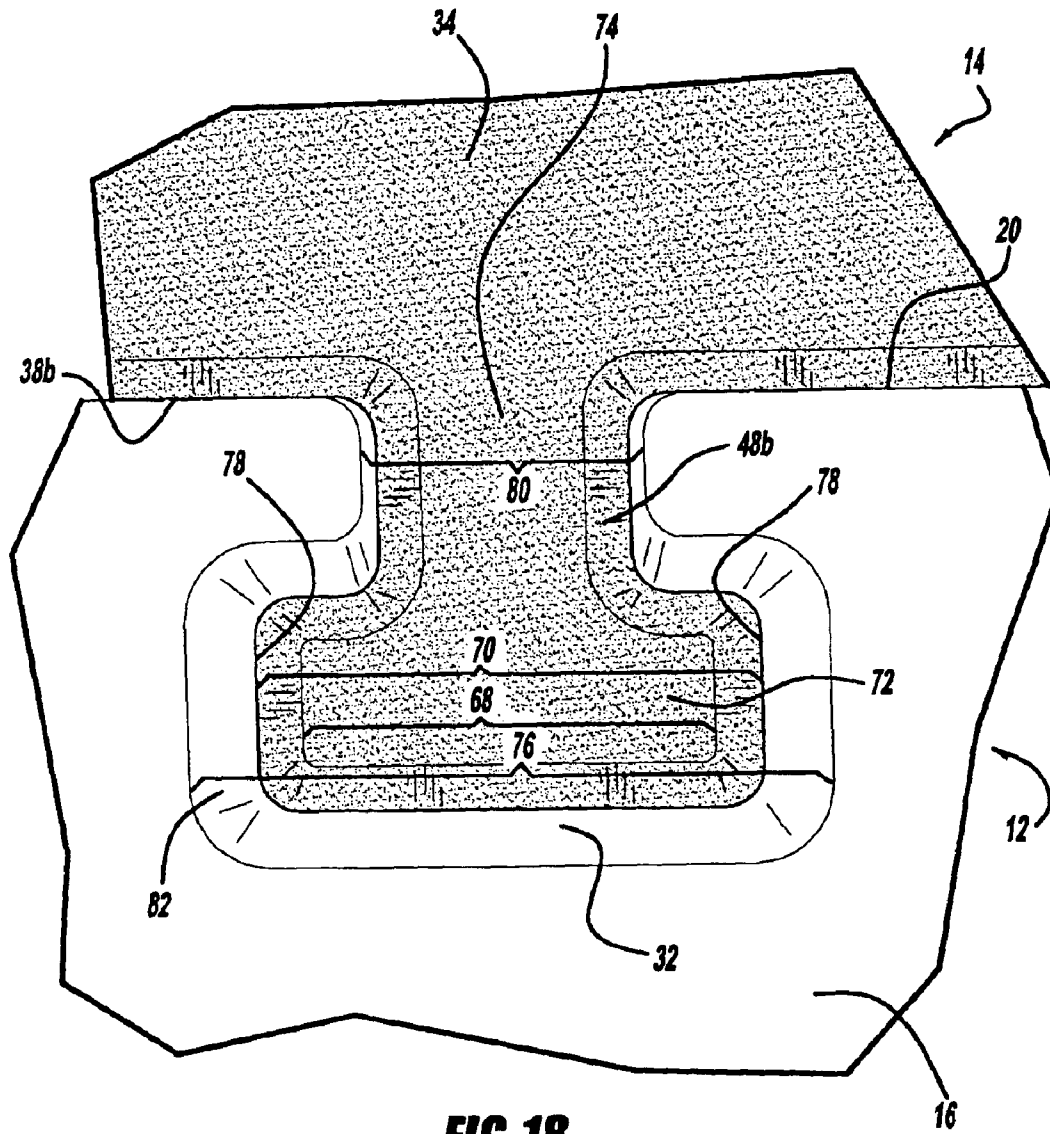


**FIG - 14**



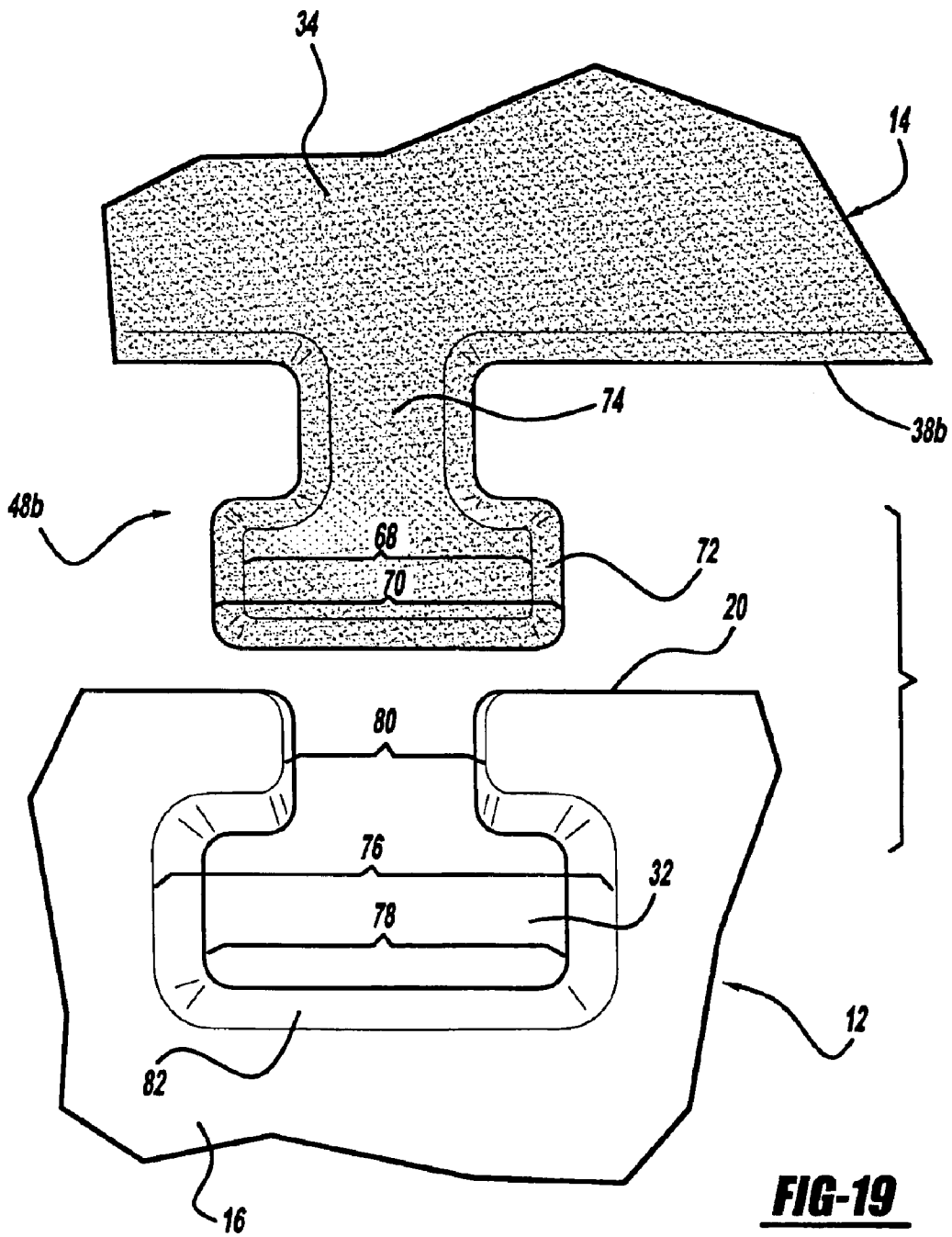
**FIG-15**





**FIG-18**





**FIG-19**

1

## VARIABLE RAMP ASSEMBLIES AND SYSTEM THEREFOR

### FIELD OF THE INVENTION

The present invention relates to ramps for providing aerial lift for sport jumping with skateboards, inline skates, bicycles and the like and, more particularly, a system for creating ramp assemblies that can be readily assembled to selectively provide obstacle courses of a variety of configurations with different challenge levels and can be readily disassembled for transport or storage.

### BACKGROUND OF THE INVENTION

There are a variety of ramp designs for skateboard, inline skates and bicycle enthusiasts for performing simple aerial jumps or complex aerial acrobatics or other forms of ramp challenges. Such activities are generally performed on straight inclined ramp surfaces or arcuate surfaces some of which may extend as much as a half pipe. In addition there are collapsible and/or modular ramp assemblies some of which are used for the transport of wheeled vehicles such as wheelchairs, carts and the like.

Even with prior modular or collapsible ramp assemblies such structures provide only limited, selective versatility of the final desired configuration and hence use.

In the present invention a system for modular ramp assemblies is provided comprising a plurality of similar ramp modules of at least two different structures which can be selectively assembled together vertically and horizontally to define ramp assemblies having a variety of desired overall configurations. Here one of the modules is an inclined ramp module having an inclined upper support, or riding surface and another module a straight module having a straight, flat upper support or riding surface. These surfaces are adapted to be readily operatively joined together to form configurations with desired contours.

With the versatile system of the present invention the modules can be selectively assembled to provide ramp assemblies of multiple lengths, multiple widths and multiple ramp elevations along with a large variety of overall contours. In addition the modules are provided with unique interfitting structures whereby the modules can be readily manually assembled and disassembled without the need for special tools. In addition each module is of a relatively lightweight structure to facilitate handling.

### SUMMARY OF THE INVENTION

In the present invention, a unique modular ramp system is provided to permit the user to selectively vary the overall contour of the ramp assembly as finally assembled.

Here a plurality of modules of at least two different configurations are used. A first module is provided with an inclined upper support or riding surface with the inclined surface extending substantially over the entire upper surface. A second module is substantially rectangular having a straight, generally horizontal planar upper support or riding surface extending substantially over the entire upper surface.

In one form the first and second modules are of substantially the same width and length. In addition the upper end of the inclined surface of the inclined ramp module is of substantially the same height as the uniform height of the rectangular module to provide continuity between the support surfaces when operatively connected together in line. This then facilitates assembly of the modules together in a large variety of selected configurations.

2

In addition, a simple, unique structure is provided for selectively interconnecting the modules together length wise (end-to-end), width wise (side-by-side), width-to-length (end-to-side) and/or stacked one on top of the other. This simple structure facilitates an ease of assembly and disassembly of the modules into a variety of overall structural ramp assemblies.

At the same time the capability of providing a selective variety of configurations of ramp assemblies can be done with the use of modules of only two different structures. This then minimizes the overall cost of manufacture for a reasonable cost to the end user.

Therefore, it is an object of the present invention to provide ramp modules of unique structures for facilitating the formation of ramp assemblies of different overall contours.

It is another object of the present invention to provide a modular ramp system having a plurality of ramp modules which can be connected together horizontally and vertically in a variety of ways to provide ramp assemblies of numerous, selectively desirable overall contours.

It is another object of the present invention to provide a modular ramp system including a plurality of ramp modules of different constructions with a structure facilitating relatively easy assembly and disassembly.

It is another object of the present invention to provide a modular ramp system including a plurality of ramp modules of two different structures to provide ramp assemblies of selectively desirable contours.

It is also an object of the present invention to provide ramp modules of unique structures for forming unique structural ramp assemblies.

It is still another object of the present invention to provide a unique modular ramp system.

Further areas of applicability of the present invention will become apparent from the detailed description provided hereinafter. It should be understood that the detailed description and specific examples, while indicating the preferred embodiment of the invention, are intended for purposes of illustration only and are not intended to limit the scope of the invention.

### BRIEF DESCRIPTION OF THE DRAWINGS

The present invention will become more fully understood from the detailed description and the accompanying drawings, wherein:

FIG. 1 is a perspective view of one form of a ramp assembly including inclined ramp modules having an inclined, straight upper riding or support surface and straight modules having a straight, planar, generally horizontal upper riding or support surface;

FIG. 1a is an enlarged fragmentary view of a portion of the ramp assembly taken generally in the Circle 1a in FIG. 1;

FIG. 2 is a perspective view similar to FIG. 1 with a number of inclined ramp modules and straight ramp modules shown in phantom and illustrating different possible horizontal and vertical interconnections between modules for forming a variety of different ramp assemblies;

FIG. 3 is an upper perspective view of an inclined ramp module with T-shaped connecting protrusions and T-shaped connecting grooves for connection with other ramp modules;

FIG. 3a is a longitudinal sectional view along the length of the inclined ramp module of FIG. 3 and taken generally along the line and in the direction of the Arrows 3a—3a in FIG. 3;

3

FIG. 4 is a front end elevational view of the inclined ramp module of FIG. 3 taken in the direction of the Arrows 4—4 in FIG. 3;

FIG. 5 is an enlarged fragmentary view with some parts shown in section of the portion of the inclined ramp module of FIG. 4 taken generally in the Circle 5 in FIG. 4;

FIG. 6 is a side elevational view of the inclined ramp module of FIG. 3 taken in the direction of the Arrows 6—6 in FIG. 3;

FIG. 7 is an upper perspective view of a straight ramp module with T-shaped connecting protrusions and T-shaped connecting grooves for connection with other ramp modules;

FIG. 7a is a longitudinal sectional view along the length of the straight ramp module of FIG. 7 and taken generally along the line and in the direction of the Arrows 7a—7a in FIG. 7;

FIG. 7b is a transverse sectional view along the width of the straight ramp module of FIG. 7 and taken generally along the line and in the direction of the Arrows 7b—7b in FIG. 7;

FIG. 7c is an enlarged, fragmentary sectional view of a bottom portion of the straight ramp module of FIG. 7 taken generally in the Circle 7c in FIG. 7b depicting the slip resistant foot member as applied to the bottom end of one of the side walls of the straight ramp module;

FIG. 7d is an enlarged end elevational view of the foot member of FIG. 7c;

FIG. 8 is an end elevational view of the straight ramp module of FIG. 7 taken in the direction of the Arrows 8—8 in FIG. 7;

FIG. 9 is a side elevational view of the straight ramp module of FIG. 7 taken in the direction of the Arrows 9—9 in FIG. 7;

FIG. 10 is a front, upper perspective view of a connector for securing the ramp modules together when stacked vertically;

FIG. 11 is a front elevational view of the connector of FIG. 10;

FIG. 12 is an exploded, fragmentary view showing the layered connection prior to assembly between a straight ramp module on the bottom and an inclined ramp module on top with connectors of FIGS. 10 and 11 for securing the ramp modules together;

FIG. 13 is a fragmentary pictorial view to enlarged scale taken generally in the Circle 13 in FIG. 1 and showing the layered connection of a straight ramp module on the bottom and an inclined ramp module stacked on top of the straight ramp module and secured together with the connector of FIGS. 10 and 11;

FIG. 14 is a fragmentary sectional view of the layered connection between the straight and inclined ramp modules by the connector of FIGS. 10 and 11 taken generally along the line and in the direction of the Arrows 14—14 in FIG. 13;

FIG. 15 is a fragmentary vertical sectional view to enlarged scale of the confronting surfaces of the T-shaped protrusion of the lower inclined ramp module and the T-shaped groove of the adjacent lower straight module of FIG. 2 when connected together and taken generally along the line and in the direction of the Arrows 15—15 in FIG. 2, with the section line in the direction of Arrows 15'—15' in FIG. 2 providing a view which would be a mirror image of FIG. 15 and thus that view has been omitted for purposes of simplicity;

4

FIG. 16 is a fragmentary view to enlarged scale of the T-shaped connecting protrusion of the straight ramp module of FIG. 8 taken generally in the Circle 16 in FIG. 8;

FIG. 17 is a fragmentary view to enlarged scale of the T-shaped connecting groove of the straight ramp module of FIG. 8 taken generally in the Circle 17 in FIG. 8;

FIG. 18 is a fragmentary view to enlarged scale taken generally vertically downwardly in the direction of the Arrows 18—18 in FIG. 2 depicting the upper end of the connection between a T-shaped connecting protrusion on the straight ramp module and a T-shaped connecting groove on the inclined ramp module; and

FIG. 19 is a fragmentary view depicting the T-shaped protrusion and T-shaped groove of FIG. 18 separated prior to assembly.

#### DETAILED DESCRIPTION OF THE PREFERRED EMBODIMENTS

The following description of the preferred embodiment(s) is merely exemplary in nature and is in no way intended to limit the invention, its application, or uses.

Looking now to FIG. 1, a modular ramp assembly 10, of one form, is shown and is made up of a plurality of inclined ramp modules 12 of one uniform structure and straight ramp modules 14 of a second uniform structure. The inclined ramp modules 12 are generally of a right triangular, wedge shape while the straight ramp modules 14 are generally of a rectangular box shape. Both the inclined ramp modules 12 and straight ramp modules 14 are of a generally lightweight, hollow construction to be described.

FIGS. 3, 4 and 6 show the inclined ramp module 12, to have an inclined, straight, planar rectangular upper support or riding surface 16 supported on opposite sides by generally triangularly shaped side walls 18a and 18b and at the upper end by a generally rectangularly shaped end wall 20. The side wall 18a has a plurality of longitudinally spaced T-shaped connecting protrusions 22a and 24a and a plurality of longitudinally spaced T-shaped connecting channel grooves 26a and 28a. As can be seen the connecting protrusions 22a and 24a are alternately spaced relative to the connecting channel grooves 26a and 28a. The opposite side wall 18b has T-shaped connecting protrusions 22b and 24b which are longitudinally offset from the opposite sided connecting protrusions 22a and 24a and are substantially in transverse alignment with the T-shaped channel grooves 26a and 28a, respectively. Likewise, the side wall 18b has T-shaped channel grooves 26b and 28b which are substantially in transverse alignment with the T-shaped protrusions 22a and 24a, respectively. Such alignment serves a connecting purpose to be described. The end wall 20 has a T-shaped connecting protrusion 30 and a T-shaped connecting channel groove 32. FIG. 5 is a fragmentary partially sectioned view depicting the upper end of the T-shaped protrusion 24a.

FIGS. 7, 8 and 9 show the straight ramp module 14.

As will be seen the T-shaped protrusions and T-shaped grooves provide a unique and simple way of slidably connecting the ramp modules to form assemblies of a variety of horizontal and vertical configurations.

The straight ramp module 14 has a generally horizontal rectangular, straight or planar upper riding or support surface 34 which is supported on opposite sides by generally rectangularly shaped side walls 36a and 36b and at opposite ends by generally rectangularly shaped front and rear end walls 38a and 38b, respectively. The side wall 36a has a pair of longitudinally spaced T-shaped connecting protrusions

**40a** and **42a** and a plurality of longitudinally spaced T-shaped connecting channel grooves **44a** and **46a**. Again, the connecting protrusions **40a** and **42a** are alternately spaced relative to the connecting channel grooves **44a** and **46a**. The opposite side wall **36b** has T-shaped connecting protrusions **40b** and **42b** which are longitudinally offset from the opposite side protrusions **40a** and **42a** and are substantially in transverse alignment with the T-shaped channel grooves **44a** and **46a**. Likewise the side wall **36b** has T-shaped connecting channel grooves **44b** and **46b** which are longitudinally offset from the opposite side channel grooves **44a** and **46a** and are substantially in transverse alignment with the T-shaped protrusions **40a** and **42a**, respectively.

The front end wall **38a** has a T-shaped connecting protrusion **48a** and a transversely spaced T-shaped connecting channel groove **50a**. The rear end wall **38b** has a T-shaped connecting protrusion **48b** in longitudinal alignment with the T-shaped channel groove **50a** and a transversely spaced T-shaped connecting channel groove **50b** in longitudinal alignment with the T-shaped protrusion **48a**.

In all of the above, the T-shaped protrusions and T-shaped grooves on the inclined ramp modules **12** and on the straight ramp modules **14** are of similar constructions and equally spaced with the T-shaped protrusions adapted to slidingly fit within the T-shaped channel grooves to connect an inclined module **12** and straight ramp module **14** together end-to-end. In this regard the shortened T-shaped protrusions **22a, b** and **24a, b** and shortened T shaped channel grooves **26a, b** and **28a, b** of the inclined ramp modules **12** are of substantially the same contour as the full length T-shaped protrusion **30** and channel groove **32** at their same lower sections.

At the same time, the transverse spacing between the protrusion **30** and channel groove **32** in the end wall **20** of inclined ramp modules **12** and between the end protrusions **48a** and **48b** and end channel grooves **50a** and **50b** in end walls **38a** and **38b** of the straight ramp modules **14** is inversely the same to provide interfitting end-to-end connection. Also the longitudinal spacing between the side protrusions **22a, 24a** and side channel grooves **26b, 28b** and side protrusions **22b, 24b** and side channel grooves **26a, 28a** in side walls **18a, 18b** of the inclined ramp modules **12** is inversely the same to provide interfitting side-by-side connection between two inclined ramp modules.

Along the same line, the protrusion **48a** and channel groove **50a** in the end wall **38a** of the straight ramp modules **14** are longitudinally in line with the channel groove **50b** and protrusion **48b**, respectively, in the opposite end wall **38b** to provide end-to-end connection. Also the longitudinal spacing between the channel grooves **44a, 46a** on side wall **36a** and protrusions **40b, 42b** on side wall **36b** is the same placing them in transverse alignment and the spacing between protrusions **40a, 42a** on side wall **36a** and channel grooves **44b, 46b** is the same also placing these in transverse alignment to provide interfitting side-by-side connection between two straight ramp modules **14**.

In this regard, it can be seen from FIG. 2 that the inversely uniform spacing of T-shaped connecting grooves and T-shaped connecting projections on the end and side surfaces of the inclined ramp modules **12** and straight ramp modules **14** are uniform whereby the end wall **20** of the inclined ramp module **12** can also be connected to either of the side walls **36a, 36b** of the straight ramp modules **14** and likewise either end wall **38a, 38b** of a straight ramp module **14** can be connected to either of the side walls **36a, 36b** of another straight ramp module **14**. Thus the inclined ramp modules **12** and straight ramp modules **14** can be connected

together in a substantial variety of vertical and horizontal combinations. Examples of such variations in assembly are shown in FIG. 2 with some members shown in phantom. In this regard, it can be seen in FIG. 2 that ramp assemblies can be selectively erected with inclined ramps **12** at the beginning and end such that there may be little or no aerial left. This clearly shows that ramp assemblies can be assembled to provide obstacle courses of a selected variety of challenge levels. It can also be seen then that the orientation of the T-shaped projections and T-shaped grooves of the inclined ramp modules **12** and straight ramp modules **14** facilitates the ease of assembly since no particular orientation is required for end-to-end or side-to-side connection.

As can be seen from FIG. 1, the width and height of the end wall **20** of the inclined ramp modules **12** and of the end walls **38a** and **38b** of the straight ramp modules **14** are the same such that an inclined ramp module **12** and straight ramp module **14** are in an in-line alignment when assembled end-to-end. In addition the lengths of the inclined ramp modules **12** and the straight ramp modules **14** are the same to provide alignment for vertical stacking when an inclined ramp module **12** is stacked on top of a straight ramp module **14**.

In order to secure the different ramp modules together for vertical stacking a separate connecting member is provided. Looking now to FIGS. 10 and 11 a connector **52** is shown and is of a generally open structure having an inner substantially enclosed portion **54** having an opening **56** at its lower end and a closed cap portion **58** at its upper end. A generally U-shaped, open flanged, channel **60** extends outwardly from the forward side. The connector **52** has an upper section **62** and a lower section **64**. The lower section **64** is somewhat larger transversely than the upper section **62** to define an outer alignment and stop ridge **66** which serves a purpose to be described.

The T-shaped connecting protrusions, such as **22a, 24a**, and T-shaped channel grooves, such as **26a, 28a**, are uniquely constructed for connecting the inclined ramp modules **12** and straight ramp modules **14** together, side-by-side or end-to-end. At the same time the connectors **52**, T-shaped protrusions and T-shaped channel grooves are uniquely constructed for providing connections between the inclined ramp modules **12** and straight ramp modules **14** for vertical stacking.

All of the T-shaped projections and T-shaped channel grooves are of an identical configuration and construction except for the shortened T-shaped protrusions **22a, b** and **24a, b** and shortened T-shaped channel grooves **26a, b** and **28a, b** on the side walls **18a, 18b** of the inclined ramp modules **12**. However, the configuration of the shortened T-shaped projections and T-shaped grooves are the same as the corresponding lower portions of the full length T-shaped projections and T-shaped grooves.

A representative example of the structure of the full length T-shaped protrusions and T-shaped channel grooves can be seen in FIG. 16 which is of the T-shaped protrusion **48a** and FIG. 17 which is of the T-shaped channel groove **50a**. These views are taken from FIG. 8 which, as can be seen, is at the front end wall **38a** of the straight ramp module **14**. Other features of the T-shaped protrusions **48a** and of the T-shaped channel groove **50a** can be seen in FIGS. 12, 15, 18 and 19.

Looking now to FIGS. 16, 18 and 19 the T-shaped protrusion **48a** is of a tapered construction with a narrower upper end **68** tapering to a wider lower end **70**. The protrusion **48a** has an outer rectangular section **72** connected to the end wall **38a** by a narrower neck section **74**. The rectangular

section 72 and neck section 74 are similarly tapered and in one form of the invention the taper angle A was selected to be around 1.5°. As can be seen in FIG. 12, the protrusion 48a is of a hollow construction with the neck section 74 opening into the generally hollow interior of the straight ramp module 14. The T-shaped protrusion 48a is closed at the upper end 68 and open at the lower end 70. In this regard, the shorter T-shaped protrusions on the side walls 18a and 18b of the inclined ramp module 12 are also hollow and closed at their upper ends as can be seen with the T-shaped protrusion 24 in FIG. 5.

Looking now to FIGS. 17, 18 and 19, the T-shaped channel groove 50a is also of a tapered construction but which is of a reverse taper relative to that of the T-shaped protrusion 48a. Thus the channel groove 50a tapers from a wider upper end 76 to a narrower lower end 78. The T-shaped channel groove 50a has an outer, slotted narrow neck section 80 connected to a wider inner rectangular groove section 82. The rectangular groove section 82 is closed at its inner surface 84 whereby the channel groove 50a is not open to the hollow interior of the straight ramp module 14. As can be seen in FIG. 17, the neck section 80 and rectangular groove section 82 are similarly tapered at an angle AA of around 1.5° which is thus substantially the same as the reverse taper angle A of the T-shaped protrusion 48a.

Looking now to FIGS. 18 and 19, the size of the T-shaped protrusion 48a at its wider lower end 70 is substantially the same as the size of the T-shaped channel groove 50a at its narrower lower end 78 to provide mating engagement at the location. However, the size of the narrower upper end 68 of the T-shaped protrusion 48a is less than the size of the wider upper end 76 of the T-shaped channel groove 50a to provide a preselected clearance for a purpose to be seen.

FIG. 15 shows the vertical relationship of the T-shaped protrusion 48a when interconnected into the T-shaped channel groove 50b. Here it can be seen that the outer rectangular section 72 is angled inwardly lengthwise from the lower end 70 to the upper end 68 at an angle B. The inner surface 84 of the rectangular groove section 82 of the T-shaped groove 50a is also angled inwardly lengthwise from the lower end 78 to the upper end 76 at angle BB. Here in one form of the invention the angle B was set at around 0.75° while the angle BB was also set at around 0.75°. This provides a preselected clearance at the upper ends 68, 76 while the lower ends 70, 78 are in mating engagement.

The noted clearances facilitate assembly of the ramp modules together for horizontal in-line connection, i.e. end-to-end, side-to-side or end-to-side. The clearance also facilitates assembly of the ramp modules in a variety of vertically stacked relationships. In addition while the tapers and inclinations of the T-shaped protrusions 48a and T-shaped channel grooves 50a facilitate assembly they also facilitate manufacture by assisting in ejection of the modules from the molds in the molding process.

As noted in order to securely stack one ramp module upon another, the connectors 52 are used. This can be seen in FIGS. 12-14 where an inclined ramp module 12 is being stacked upon a straight ramp module 14. First each of the connectors 52 is located over the upper end 68 of the T-shaped protrusions such as protrusions 42a and 48a. Here the lower section 64 of the connector 52 will fit snugly on the upper end 68. With the connectors 52 in place next the inclined ramp module 12 is placed on top of the straight ramp module 14 with the T-shaped protrusion 24a on the side wall 18a and protrusion 30 on the end wall 20 in line with the T-shaped protrusion 42a on the side wall 36a and

the T-shaped protrusion 48a on the front end wall 38a. The opening at the lower end 70 of the T-shaped protrusion 48a is of a contour to move over the upper section 62 of the connector 52 with the bottom side of the lower end 70 of the T-shaped protrusion 48a engaging the outer stop ridge 66. The inclined ramp module 12 is pressed downwardly until the bottom of the inclined ramp module 12 engages the straight, planar upper riding or support surface 34 of the straight ramp module 14.

Where the vertical stacking is an inclined ramp module 12 on a straight ramp module 14, connectors 52 will be applied to the T-shaped protrusions on both side walls 36a, 36b and the front end wall 38a. Where a straight ramp module 14 is stacked on top of another straight ramp module 14, then connectors 52 will be applied to each of the T-shaped protrusions on both side walls 36a, 36b and both end walls 38a, 38b.

In the event, it is desired to double the width of the ramp assembly 10, a second straight ramp module 14 will first be secured side-by-side to the first straight ramp module 14 with the opposite side wall 36b located next to the side wall 36a. Here the T-shaped protrusions 40a, 42a will be connected with the T-shaped grooves 44b, 46b and the T-shaped grooves 44a and 46a will be connected with the T-shaped protrusions 40b, 42b. Now the connectors 52 will be located over the T-shaped protrusions 40a, 42a and in a generally clearance fit in the related T-shaped grooves 44b, 46b. The clearance between the upper end of a T-shaped protrusion 48b and the upper end of a T-shaped groove 32 can be readily seen in FIGS. 18 and 19. Now the inclined ramp module 12 will be assembled onto the first straight ramp module 14, as noted. Next a second inclined ramp module 12 will be placed on top of the second straight ramp module 14 with the T-shaped protrusions 22b, 24b on side wall 18b located in the T-shaped grooves 26a, 28a on side wall 18a and also with the T-shaped protrusions 22a, 24a on the side wall 18a located in the T-shaped grooves 26b, 28b on the side wall 18b. In addition further stacked connection could be provided between the side-to-side surfaces utilizing connectors 52 between the T-shaped protrusion 40b and 42b on the straight ramp module 14 and the T-shaped protrusions 22b and 24b on the inclined ramp module 12. It can be seen, however, that the straight ramp module 14 can be connected side-by-side with two side walls 36a or two side walls 36b connected together by simply rotating the second ramp module 14 by 180°. This will bring the T-shaped protrusions 22a, 24a and the T-shaped grooves 26a, 26b on the second side wall 18a in alignment with the T-shaped grooves 26a, 26b and T-shaped protrusions 22a, 24a on the first side wall 18a. The same versatility is true in connecting one end wall 38a to another end wall 38a or 38b to 38b for end-to-end connection.

As can be seen from FIGS. 1 and 2, the ramp system of the present invention permits the user to create ramp assemblies of varying configurations. An example of one such ramp assembly 10 is shown in FIG. 1. Here a first inclined ramp module 12 is connected end-to-end with a first straight ramp module 14 at ground level. This is done simply by slidably moving the T-shaped protrusion 48b on the end wall 38b into the T-shaped channel groove 32 on the end wall 20 and at the same time moving the T-shaped channel groove 50b on the end wall 38b over the T-shaped protrusion 30 on the end wall 20. In this regard a similar connection could be made with the end wall 38a. Next the overall length can be extended by connecting a second straight ramp module 14 end-to-end with the first straight ramp module 14 at ground level. This is done similarly to the above by placing the

T-shaped protrusion **48b** on the rear end wall **38b** into the T-shaped channel groove **50a** on the front end wall **38a** and slidably moving the T-shaped channel groove **50b** on the rear end wall **38b** over the T-shaped protrusion **48a** on the front end wall **38a**.

Now a second inclined ramp module **12** is placed on the upper riding or support surface **34** on the first straight ramp module **14**. These stacked ramp modules **12** and **14** are then connected together by use of the connectors **52**. Looking now to FIGS. **10–12**, connectors **52** are located over the upper ends of the T-shaped protrusions **40a, b** and **42a, b** on the side wall **36a** of straight ramp module **14** and on the T-shaped protrusion **48a** on the front end wall **38a**.

Now to extend the height of the ramp assembly **10** as shown a third straight ramp module **14** is located on the planar upper support surface **34** of the second straight ramp module **14**. As this is done the T-shaped channel groove **50b** and T-shaped protrusion **48b** on the rear end wall **38b** of the second straight module **14** are interconnected with the T-shaped protrusion **30** and T-shaped channel groove **32** on the front end wall **20** of the second inclined module **12**. At the same time connectors **52** have already been located on the upper ends of the T-shaped protrusions **40a, b** and **42a, b** of the second straight module **14** and are moved into the lower ends of the aligned T-shaped protrusions **40a, b** and **42a, b** on the third straight module **14**. This is done by moving the lower or bottom end of the T-shaped protrusions **40a, b** and **42a, b** over the upper section **62** of the connectors **52** against the outer stop ridge **66**.

Now the assembly **10** is completed by locating a third inclined ramp module **12** on the planar upper support surface **34** of the third straight ramp module **14**. Again the connectors **52** are first located over the upper ends of the T-shaped protrusions **40a, b** and **42a, b** and the T-shaped protrusions **22a, b** and **24a, b** are located over the upper section **62** of the connectors **52** to secure the modules together.

The outer edge of the riding or support surface **16** at the end wall **20** of the inclined ramp modules **12** and the outer edges of the riding or support surface **34** at the end walls **38a, b** of the straight ramp modules **14** are arcuately formed to avoid stress. Such arcuate outer edges **86** and **88** are shown in FIG. **1a**. In order to cover the slight gap between the adjacent edges **86** and **88** at the juncture of the end walls **20** and **38b**, the inclined riding or support surface **16** of the inclined module **12** is provided with a somewhat flexible, generally tapered lip **90** at its lower, front end. This provides for a relatively smooth transition between the two adjacent inclined support surfaces **16** on the lower and upper inclined ramp modules **12** so as to render the gap between the adjacent edges **86** and **88** substantially imperceptible to the user.

FIG. **2** shows examples of the variety of horizontal and vertical interconnections between the inclined ramp modules **12** and straight ramp modules **14** to provide a selective variety of modular ramp assemblies generally indicated by the numeral **10**. As noted a number of the inclined ramp modules **12** and straight modules **14**, are shown in phantom to indicate the variety of interconnections for different ramp assemblies. Thus the same end user can have the versatility of setting up ramp assemblies of different configurations for different objectives and even different uses, i.e. inline skates, skateboards, etc. This then allows the user to set up ramp assembly obstacle courses with different degrees of challenge.

Both the inclined upper riding or support surface **16** on the inclined ramp module **12** and the straight planar upper riding

or support surface **34** on the straight ramp module **14** can be roughened to enhance gripping of the engaging rolling member such as bike tires, skate rollers, etc. and to assist in traction and to inhibit slippage especially if wet. In one form, the roughened surfaces were formed in molding. However, it should be understood that such roughened surfaces could be created after molding. In this regard, it can be seen in FIG. **7** that in some forms of a ramp assembly the planar upper support surface **34** of at least one straight ramp module **14** will be exposed for engagement by the rolling member. For purposes of simplicity of the drawings only the inclined ramp module **12** in FIGS. **3** and **4** and straight ramp module **14** in FIG. **7** are shown with roughened surfaces.

As noted, both the inclined ramp modules **12** and straight ramp modules **14** are of a hollow construction and as such are designed to be molded from a plastic material. In one form of the invention the plastic material was a high density polyethylene (HDPE). In this regard, the connectors **52** can be molded from the same material.

In order to facilitate molding of the inclined ramp modules **12** and straight ramp modules **14** and to provide modules that are relatively light weight, a hollow structure is provided with numerous internal ribs.

Such a structure for the inclined ramp module **12** can be seen in the longitudinal section of FIG. **3a**. There, a plurality of longitudinally extending main ribs **92** connect the inclined riding or support surface **16** with the end wall **20**. Only one rib **92** is shown for purposes of simplicity. At the same time a plurality of transverse main ribs **94** are connected between the inclined support surface **16**, the side walls **18a, 18b**, and the longitudinal ribs **92**. The center portions of the ribs **92** and **94** are of a reduced vertical length while the sides extend to the bottom.

The internal structure for the straight ramp module **14** can be seen in FIGS. **7a** and **7b**. FIG. **7a** shows a plurality of longitudinally extending main ribs **96** which connect the riding or support surface **34** with end walls **38a, b**. FIG. **7b** shows a plurality of transversely extending main ribs **98** which connect the support surface **34** with the side walls **36a, b** and are interconnected with the longitudinal ribs **96**. Again the center portions of the ribs **96** and **98** are of a reduced vertical length while the sides extend to the bottom. These structures facilitate the molding process and the production of the inclined modules **12** and straight module **14** of a lightweight structure.

In one form of the invention the inclined module **12** and straight module **14**, generally of the construction noted, each has five generally equally spaced longitudinal main ribs **92** and **96**, respectively, and five generally equally spaced transverse main ribs **94, 98**, respectively. As noted the longitudinal main ribs **92** and **96** extend for substantially the full length of the ramp modules **12** and **14** while the transverse main ribs **94** and **98** extend for substantially the full width of the ramp modules **12** and **14**. In addition, the inclined module **12** has four longitudinal rib segments **93** in between the five longitudinal main ribs **92** and four transverse rib segments **95** in between the five transverse main ribs **94**. The rib segments **93** and **95** are also connected to the support surface **16** but do not extend for the full length or full width of the inclined ramp module **12**. Similarly, each of the straight ramp modules **14** has four longitudinal rib segments **97** in between the five longitudinal main ribs **96** and four transverse rib segments **99** in between the five transverse main ribs **98**. The rib segments **97** and **99** are also connected to the planar support surface **34** but which do not extend for the full length or full width of the straight ramp module **14**.

11

As can be seen the overall strength and rigidity of the riding or support surfaces **16** and **34** are thereby substantially enhanced. Also it can be seen that the outer lower ends of the main ribs **92** and **94** of the inclined ramp module **12** and the main ribs **96** and **98** of the straight ramp module **14** extend to the bottom of the respective ramp modules **12** and **14**. These then provide a distributed support surface against the ground or when engaged with the riding or support surfaces **34** when in a stacked condition.

In this regard, in one form of the invention the inclined modules **12** and straight modules **14** were made with side walls **18a, b** and **36a, b** of the same longitudinal length (Li, Ls), and end walls **20** and **38a, b** of the same transverse width (Wi, Ws), and of the same vertical height (Hi, Hs). As such in one form, the longitudinal length (Li, Ls), was around **36** inches, the transverse width (Wi, Ws) was around **25.5** inches and the vertical height (Hi, Hs) was around **12** inches. In this regard, the tapered lip **90** extends longitudinally slightly past the length Li of side walls **18a, b** at the lower end to provide the desired coverage of the gap between the confronting edges **86** and **88** of the adjacent end walls **20** and **38b**. Also in this form the angle of inclination AI of the riding or support surface **16** of the inclined module **12** was selected to be around **19°**. With such a structure the support surfaces **16** and **34** and main ribs **92, 94, 96** and **98** could be made of a relatively small gauge or thickness. As such the support surfaces **16** and **34** could be made around **0.140** inches thick; the side walls **18a, b** and **36a, b** and end walls **20** and **38a, b** could be made around **0.100** inches thick; and the main ribs **92, 94, 96** and **98** could be made around **0.060** inches thick. The rib segments **93, 95, 97** and **99** could be of the same thickness as the main ribs **92, 94, 96** and **98**. Some of the above structures would be somewhat slightly tapered to facilitate molding. Such hollow, relatively thin wall constructions can produce generally lightweight ramp modules, i.e. around **17** pounds for the straight module **14** and around **11** pounds for the inclined module **12**. Yet it is believed that the constructions as noted can safely handle loads at least up to **300** pounds.

In order to provide resistance to slippage on the ground level a foot member can be provided to be selectively placed on portions of the bottom ends of the side walls **18a, b** and **36a, b** and the end walls **20** and **38a, b**. Such a foot member **100** can be seen in FIG. **7c** as applied to side wall **36a** and in FIG. **7d** prior to application to a side wall **36a**. Here the foot member **100** is provided of a generally U-shaped cross-section having an open channel **102** which is of a size to be snugly located on the bottom end of the outer side walls and outer end walls of the inclined ramp modules **12** and straight ramp modules **14** of a ramp assembly.

Looking now to FIG. **7d** the U-shaped foot member **100** has a substantially wider bottom engagement segment **104** to provide a desired amount of surface contact with the surface on which the ramp assembly **10** is located to inhibit slippage. The foot member **100** has a lower section **106** which is of a generally uniform wall thickness and is connected to an upper tapered section **108** of varying reduced wall thickness. At the same time an upper open end **110** of the foot member **100** is partially closed while the lower end **112** is of a width substantially the same as the wall thickness of the outer side walls **18a, b** and **36a, b** and outer end walls **36a, b**. Thus the foot member **100** can be resiliently moved through the open end **110** onto the outer side walls **18a, b** and **36a, b** and end walls **38a, b** with the upper section **108** closing to grip the side walls and end walls to assist in retaining the foot member **100** in place. In addition the foot member **100** can also be applied to the outer lower ends of the main ribs **92,**

12

**94, 96** and **98**. In this regard, the main ribs **92, 94, 96** and **98** are of a lesser thickness than that of the side walls **18a, b** and **36a, b** and end walls **20** and **38a, b**. This will provide a clearance with the lower end **112** of the channel **102**. However, the open end **110** of the foot member **100** will still be moved apart resiliently upon application over the main ribs **92, 94, 96** and **98** and will be closed to grip the main ribs **92, 94, 96** and **98** to retain the foot member **100** in place. The foot member **100** is also made of a generally resilient, elastic material such as an EPDM rubber of around **75** to around **80** durometer whereby discontinuities in the ground supporting surface can also be substantially accommodated. The foot member **100** can be simply made of strips which can be cut to preselected limited lengths to fit the accessible portions at the bottom ends of the outer side walls **18a, b** and **36a, b** and outer end walls **38a, b**. It could also be applied to the end wall **20** only where a single inclined ramp module **12** is used alone. In one form, the engagement segment **104** was made around **0.30** inches wide. For purposes of simplicity the foot member **100** is shown only applied to the straight ramp module **14** in FIGS. **7a** and **7b**. It should be understood that the foot member **100** may not need to be applied to each of the multiple locations as shown. It should be noted that even where the foot member **100** is not applied to the main ribs **92, 94, 96** and **98**, there could still be ground contact by the lower ends of the main ribs when riding load is being applied as the foot member **100** elastically deforms.

Thus it can be seen that the ramp assemblies of various configurations can be readily assembled and disassembled by vertical sliding movement to engage or disengage the T-shaped protrusions from the T-shaped channel grooves and a simple type of action for stacking or unstacking the ramp modules.

The description of the invention is merely exemplary in nature and, thus, variations that do not depart from the gist of the invention are intended to be within the scope of the invention. Such variations are not to be regarded as a departure from the spirit and scope of the invention.

What is claimed is:

**1.** A ramp system for forming ramp assemblies of selectively variable configurations for providing aerial lift to users of rideable wheeled recreational products including skates, skateboards and bicycles comprising ramp modules of at least two different configurations, one of said at least two ramp module configurations being an inclined ramp module having an upper support surface which is inclined for substantially its full engageable riding length and is supported on generally triangularly shaped side walls substantially over its length, said inclined ramp module having an end wall at one end of said side walls and at the upper end of said inclined surface, another of said at least two module configurations being a straight ramp module having a generally horizontal, planar upper support surface supported on generally rectangularly shaped side walls substantially over its length, said straight ramp module having end walls at opposite ends of said side walls and said straight support surface, said inclined ramp module having a bottom side engageable with a ground surface and alternatively adapted to be supported upon said planar support surface of said straight ramp module in a stacked relationship, said straight ramp module having a bottom side engageable with a ground surface, said end wall of said inclined ramp module adapted to be secured to one of said end walls of said straight ramp module for end-to-end assembly,

said end wall of said inclined ramp module and said end walls of said straight ramp module having substantially the same transverse width and substantially the same

13

vertical height and with said side walls of said inclined ramp module and said side walls of said straight ramp module having substantially the same longitudinal length, said transverse width of said end walls of said straight and inclined ramp modules being no greater than said longitudinal length of said side walls of said straight ramp module.

2. The ramp system of claim 1 with said bottom side of said straight ramp module adapted to be supported on said planar support surface of another of said straight ramp modules in a stacked relationship.

3. The ramp system of claim 1 with either of said end walls at the ends of said straight ramp module adapted to be secured to the opposite end wall of another of said straight ramp modules and to said end wall of said inclined ramp module for end-to-end assembly with connecting means integrally formed on each of said end walls and adapted to interengage each other to secure said ramp modules together.

4. The ramp system of claim 1 wherein said inclined and straight upper support surfaces being of a substantially uniform contour and having a textured, roughened finish to inhibit slippage.

5. The ramp system of claim 1 wherein said ramp modules of at least two different configurations are made from a high density plastic such as a high density polyethylene.

6. The ramp system of claim 1 wherein the angle of inclination of said inclined upper support surface on said inclined ramp module is about 19°, said end wall of said inclined ramp module and said end walls of said straight ramp module each having a transverse width of around 25.5 inches and vertical height of around 12 inches, said side walls of said inclined ramp module and said side walls of said straight ramp module having a longitudinal length of around 36 inches.

7. The ramp system of claim 1 with said inclined ramp module being of a generally hollow structure with said triangularly shaped side walls and end wall being of a relatively thin wall thickness, the lower extremities of said triangularly shaped side walls and end wall defining the bottom side of said inclined ramp module, said inclined ramp module having a plurality of longitudinally and transversely extending internal ribs, at least some of said internal ribs having at least a bottom portion extending inwardly and downwardly from said upper surface with substantially no distortion of said upper support surface to substantially the same location as the extremities of said triangularly shaped side walls and said end wall to provide further support for said inclined ramp module at said bottom side, said straight ramp module being of a generally hollow structure with said rectangularly shaped side walls and said end walls at opposite ends being of a relatively thin wall thickness, the lower extremities of said rectangularly shaped side walls and said end walls defining the bottom side of said straight ramp module, said straight ramp module having a plurality of longitudinally and transversely extending internal ribs of a generally thin wall thickness,

at least some of said internal ribs having at least a bottom portion extending inwardly and downwardly from said flat upper surface with substantially no distortion of said flat upper support surface to substantially the same location as the extremities of said rectangularly shaped side walls and said end wall to provide further support for said straight ramp module at said bottom side, at least some of said ribs extending inwardly from the bottom of said inclined upper support surface with the contour of said upper support surface being substantially uniformly flat over its length including the area

14

where said some of said ribs extend inwardly from the bottom of said inclined surface.

8. The ramp system of claim 1 with said end wall of said inclined ramp module and said end walls of said straight ramp module constructed to be connected to said side walls of said straight ramp module for end-to-side alignment.

9. The ramp system of claim 1 with said lengths of said inclined ramp module and said straight ramp module being selected such that when one inclined ramp module is connected in end-to-end assembly with one straight ramp module and a second inclined ramp module is supported on said straight ramp module, said inclined upper surfaces of said inclined ramp modules are in angular alignment with substantially no gap between their adjacent ends.

10. A ramp system for forming ramp assemblies of selectively variable configurations for providing aerial lift to users of rideable wheeled recreational products including skates, skateboards and bicycles comprising ramp modules of at least two different configurations, one of said at least two ramp module configurations being an inclined ramp module having an upper support surface which is inclined for substantially its full engageable riding length and is supported on generally triangularly shaped side walls substantially over its length, said inclined ramp module having an end wall at one end of said side walls and at the upper end of said inclined surface, another of said at least two module configurations being a straight ramp module having a generally horizontal, planar upper support surface supported on generally rectangularly shaped side walls substantially over its length, said straight ramp module having end walls at opposite ends of said side walls and said straight support surface, said inclined ramp module having a bottom side engageable with a ground surface and alternatively adapted to be supported upon said planar support surface of said straight ramp module in a stacked relationship, said straight ramp module having a bottom side engageable with a ground surface, said end wall of said inclined ramp module adapted to be secured to one of said end walls of said straight ramp module for end-to-end assembly, said inclined ramp module and said straight ramp module being of substantially the same length,

said inclined ramp module being of a generally hollow structure with said triangularly shaped side walls and end wall being of a relatively thin wall thickness, the lower extremities of said triangularly shaped side walls and end wall defining the bottom side of said inclined ramp module, said upper support surface being substantially uniformly flat over its length, said inclined ramp module having a plurality of generally flat internal ribs extending longitudinally and transversely across the bottom of said flat upper support surface at spaced intervals with substantially no distortion of said flat upper support surface, at least some of said internal ribs having end sections with a bottom portion extending inwardly from said flat upper surface and downwardly to substantially the same location as the extremities of said triangularly shaped side walls and said end wall to provide further support for said flat upper support surface and said side walls and end wall of said inclined ramp module at said bottom side.

11. The ramp system of claim 10 with said straight ramp module being of a generally hollow structure with said rectangularly shaped side walls and said end walls at opposite ends being of a relatively thin wall thickness, the lower extremities of said rectangularly shaped side walls and said end walls defining the bottom side of said straight ramp module, said planar upper surface being substantially uni-



15

formly flat over its length, said straight ramp module having a plurality of generally flat internal ribs extending longitudinally and transversely across the bottom of said flat upper support surface at spaced intervals with substantially no distortion of said flat upper support surface, at least some of said internal ribs having end sections with a bottom portion extending inwardly and downwardly from said flat upper surface to substantially the same location as the extremities of said rectangularly side walls and said end walls to provide further support for said flat upper support surface and said side walls and end walls of said straight ramp module at said bottom side.

**12.** The ramp system of claim **10** including a foot member which is a strip-like generally U-shaped resilient structure adapted to be located on edges on at least one of said bottom side of said inclined ramp module and said bottom side of said straight module for contacting the ground surface to inhibit slippage,

said foot member adapted to be applied to the edges on at least one of said lower extremities of said triangularly shaped side walls and to the edges at said bottom portion of said some of said ribs of said inclined ramp module,

said U-shaped structure having a channel portion with side sections spaced to accept said edges of varying thickness of said lower extremities of said triangularly shaped side walls and said some of said ribs, said channel portion having an opening at its upper end with said side sections being located proximate to each other to at least partially close said opening and adapted to be resiliently moved apart when said edges are moved into said channel portion and to close to resiliently grip said edges to retain said foot member to said edges.

**13.** A ramp system for forming ramp assemblies of selectively variable configurations for providing aerial lift to users of rideable wheeled recreational products including skates, skateboards and bicycles comprising ramp modules of at least two different configurations, one of said at least two ramp module configurations being an inclined ramp module having an upper support surface which is inclined for substantially its full engageable riding length and is supported on generally triangularly shaped side walls substantially over its length, said inclined ramp module having an end wall at one end of said side walls and at the upper end of said inclined surface, another of said at least two module configurations being a straight ramp module having a generally horizontal, planar upper support surface supported on generally rectangularly shaped side walls substantially over its length, said straight ramp module having end walls at opposite ends of said side walls and said straight support surface, said inclined ramp module having a bottom side engageable with a ground surface and alternatively adapted to be supported upon said planar support surface of said straight ramp module in a stacked relationship, said straight ramp module having a bottom side engageable with a ground surface, said end wall of said inclined ramp module adapted to be secured to one of said end walls of said straight ramp module for end-to-end assembly, said inclined ramp module and said straight ramp module being of substantially the same length,

said straight ramp module being of a generally hollow structure with said rectangularly shaped side walls and said end walls at opposite ends being of a relatively thin wall thickness, the lower extremities of said rectangularly shaped side walls and said end walls defining the bottom side of said straight ramp module, said planar upper surface being substantially uniformly flat over its

16

length, said straight ramp module having a plurality of generally flat internal ribs extending longitudinally and transversely across the bottom of said flat upper support surface at spaced intervals with substantially no distortion of said flat upper support surface, at least some of said internal ribs having end sections with a bottom portion extending inwardly and downwardly from said flat upper surface to substantially the same location as the extremities of said rectangularly shaped side walls and said end wall to provide further support for said flat upper support surface and side walls and end walls of said straight ramp module at said bottom side.

**14.** The ramp system of claim **13** including a foot member which is a strip-like generally U-shaped resilient structure adapted to be located on edges on at least one of said bottom side of said inclined ramp module and said bottom side of said straight module for contacting the ground surface to inhibit slippage, said foot member adapted to be applied to the edges on at least one of said lower extremities of said rectangularly shaped side walls and to the edges at said bottom portion of said some of said ribs of said straight ramp module, said U-shaped structure having a channel portion with side sections spaced to accept said edges of varying thickness of said lower extremities of said rectangularly shaped side walls and said some of said ribs, said channel portion having an opening at its upper end with said side sections being located proximate to each other to at least partially close said opening and adapted to be resiliently moved apart when said edges are moved into said channel portion and to close to resiliently grip said edges to retain said foot member to said edges.

**15.** A ramp system for forming ramp assemblies of selectively variable configurations for providing aerial lift to users of rideable wheeled recreational products including skates, skateboards and bicycles comprising ramp modules of at least two different configurations, one of said at least two ramp module configurations being an inclined ramp module having an inclined upper support surface supported on generally triangularly shaped side walls substantially over its length, said inclined ramp module having an end wall at one end of said side walls and at the upper end of said inclined surface, another of said at least two module configurations being a straight ramp module having a generally horizontal, planar upper support surface supported on generally rectangularly shaped side walls substantially over its length, said straight ramp module having end walls at opposite ends of said side walls and said straight support surface, said inclined ramp module having a bottom side engageable with a ground surface and alternatively adapted to be supported upon said planar support surface of said straight ramp module in a stacked relationship, said straight ramp module having a bottom side engageable with a ground surface, said end wall of said inclined ramp module adapted to be secured to one of said end walls of said straight ramp module for end-to-end assembly, a foot member which is a strip-like generally U-shaped resilient structure adapted to be located on edges on at least one of said bottom side of said inclined ramp module and said bottom side of said straight module for contacting the ground surface to inhibit slippage,

said U-shaped structure having a channel portion with side sections spaced to accept said edges of varying thickness, said channel portion having an opening at its upper end with said side sections being located proximate to each other to at least partially close said opening and adapted to be resiliently moved apart when said edges are moved into said channel portion and to

17

close to resiliently grip said edges to retain said foot member to said edges.

16. A ramp system for forming ramp assemblies of selectively variable configurations for providing aerial lift to users of rideable wheeled recreational products including skates, skateboards and bicycles comprising ramp modules of at least two different configurations, one of said at least two ramp module configurations being an inclined ramp module having an upper support surface which is inclined for substantially its full engageable length and is supported on generally triangularly shaped side walls substantially over its length, said inclined ramp module having an end wall at one end of said side walls and at the upper end of said inclined surface, another of said at least two module configurations being a straight ramp module having a generally horizontal, planar upper support surface supported on generally rectangularly shaped side walls substantially over its length, said straight ramp module having end walls at opposite ends of said side walls and said straight support surface, said inclined ramp module having a bottom side engageable with a ground surface and alternatively adapted to be supported upon said planar support surface of said straight ramp module in a stacked relationship, said straight ramp module having a bottom side engageable with a ground surface, said end wall of said inclined ramp module adapted to be secured to one of said end walls of said straight ramp module for end-to-end assembly, first attachment means for connecting selected ones of said inclined ramp modules and said straight ramp modules for end-to-end alignment, said first attachment means comprising at least one T-shaped protrusion and at least one T-shaped channel groove both integrally formed on said end wall of said inclined ramp module and on said end wall of said straight ramp module with the same spacing between each, said T-shaped protrusion on one of said ramp modules adapted to be slidingly, matingly moved into said T-shaped channel groove on another of said ramp modules with said T-shaped protrusion on said another of said ramp modules being slidingly, matingly moved into said T-shaped channel groove on said one of said ramp modules,

said T-shaped protrusions having an attaching structure at their ends which are constructed to be vertically in line when two of said ramp modules are in a stacked assembly, separate connecting means constructed to engage said attaching structures of stacked ramp modules when in line to connect said ramp modules together in the stacked condition.

17. The ramp system of claim 16 including second attachment means for connecting selected ones of said inclined ramp modules and said straight ramp modules for side-by-side alignment.

18. The ramp system of claim 17 with said second attachment means comprising at least one T-shaped protrusion and at least one T-shaped channel groove integrally formed on said triangularly shaped side walls of said inclined ramp module and on said rectangularly shaped side walls of said straight ramp module with the same spacing between each, said T-shaped protrusion on one of said inclined ramp modules adapted to be slidingly, matingly moved into said T-shaped channel groove on another of said inclined ramp modules with said T-shaped protrusion on said another of said inclined ramp modules being slidingly, matingly moved into said T-shaped channel groove on said one of said inclined ramp modules, said T-shaped protrusion on one of said straight ramp modules adapted to be slidingly, matingly moved into said T-shaped channel groove on another of said straight ramp modules with said T-shaped

18

protrusion on said another of said straight ramp modules being slidingly, matingly moved into said T-shaped channel groove on said one of said straight ramp modules.

19. The ramp system of claim 18 with said T-shaped channel grooves and said T-shaped protrusions of said first and second attachment means being equally spaced with said T-shaped protrusions and said T-shaped channel grooves of said first attachment means being operable with said T-shaped protrusions and said T-shaped channel grooves of said second attachment means for connecting selected ones of said inclined ramp modules and said straight ramp modules for end-to-side alignment, the width of said inclined ramp modules being no greater than the length of said straight ramp modules.

20. A ramp system for forming ramp assemblies of selectively variable configurations for providing aerial lift to users of rideable wheeled recreational products including skates, skateboards and bicycles comprising ramp modules of at least two different configurations, one of said at least two ramp module configurations being an inclined ramp module having an inclined upper support surface supported on generally triangularly shaped side walls substantially over its length, said inclined ramp module having an end wall at one end of said side walls and at the upper end of said inclined surface, another of said at least two module configurations being a straight ramp module having a generally horizontal, planar upper support surface supported on generally rectangularly shaped side walls substantially over its length, said straight ramp module having end walls at opposite ends of said side walls and said straight support surface, said inclined ramp module having a bottom side engageable with a ground surface and alternatively adapted to be supported upon said planar support surface of said straight ramp module in a stacked relationship, said straight ramp module having a bottom side engageable with a ground surface, said end wall of said inclined ramp module adapted to be secured to one of said end walls of said straight ramp module for end-to-end assembly, first attachment means for connecting selected ones of said inclined ramp modules and said straight ramp modules for end-to-end alignment, said first attachment means comprising at least one T-shaped protrusion and at least one T-shaped channel groove on said end wall of said inclined ramp module and on said end wall of said straight ramp module with the same spacing between each, said T-shaped protrusion on one of said ramp modules adapted to be slidingly, matingly moved into said T-shaped channel groove on another of said ramp modules with said T-shaped protrusion on said another of said ramp modules being slidingly matingly moved into said T-shaped channel groove on said one of said ramp modules, said T-shaped protrusions having a configuration tapering from a large protrusion section on its lower end to a small protrusion section at its upper end, said T-shaped channel groove having a configuration tapering from a small groove section at its lower end to a large groove section at its upper end,

said large protrusion section at the lower end of said T-shaped protrusion adapted to be located in said small groove section at the lower end of said T-shaped channel groove with a relatively close tolerance fit.

21. The ramp system of claim 20 including second attachment means for connecting selected ones of said inclined ramp modules and said straight ramp modules for side-by-side alignment, said second attachment means comprising at least one T-shaped protrusion and at least one T-shaped channel groove on said triangularly shaped side walls of said inclined ramp module and on said rectangularly

19

shaped side walls of said straight ramp module with the same spacing between each, said T-shaped protrusion on one of said inclined ramp modules adapted to be slidingly, matingly moved into said T-shaped channel groove on another of said inclined ramp modules with said T-shaped protrusion on said another of said inclined ramp modules being slidingly, matingly moved into said T-shaped channel groove on said one of said inclined ramp modules, said T-shaped protrusion on one of said straight, ramp modules adapted to be slidingly, matingly moved into said T-shaped channel groove on another of said straight ramp modules with said T-shaped protrusion on said another of said straight ramp modules being slidingly, matingly moved into said T-shaped channel groove on said one of said straight ramp modules, said T-shaped protrusion having a configuration tapering from a large protrusion section on its lower end to a small protrusion section at its upper end,

said T-shaped channel groove having a configuration tapering from a small groove section at its lower end to a large groove section at its upper end,

said large protrusion section at the lower end of said T-shaped protrusion adapted to be in said smaller groove section at the lower end of said T-shaped channel groove with a relatively close tolerance fit.

22. A ramp system for forming ramp assemblies of selectively variable configurations for providing aerial lift to users of rideable wheeled recreational products including skates, skateboards and bicycles comprising ramp modules of at least two different configurations, one of said at least two ramp module configurations being an inclined ramp module having an upper support surface which is inclined for substantially its full engageable riding length and is supported on generally triangularly shaped side walls substantially over its length, said inclined ramp module having an end wall at one end of said side walls and at the upper end of said inclined surface, another of said at least two module configurations being a straight ramp module having a generally horizontal, planar upper support surface supported on generally rectangularly shaped side walls substantially over its length, said straight ramp module having end walls at opposite ends of said side walls and said straight support surface, said inclined ramp module having a bottom side engageable with a ground surface and alternatively adapted to be supported upon said planar support surface of said straight ramp module in a stacked relationship, said straight ramp module having a bottom side engageable with a ground surface, said end wall of said inclined ramp module adapted to be secured to one of said end walls of said straight ramp module for end-to-end assembly, said inclined ramp module and said straight ramp module being of substantially the, same length, first attachment means for connecting selected ones of said inclined ramp modules and said straight ramp modules for end-to-end alignment and second attachment means for connecting selected ones of said inclined ramp modules and said straight ramp modules for side-by-side alignment, said first attachment means comprising at least one T-shaped protrusion and at least one T-shaped channel groove both integrally formed on said end wall of said inclined ramp module and on said end wall of said straight ramp module with the same spacing between each, said T-shaped protrusion on one of said ramp modules adapted to be slidingly, matingly moved into said T-shaped channel groove on another of said ramp modules with said T-shaped protrusion on said another of said ramp modules being slidingly, matingly moved into said T-shaped channel groove on said one of said ramp modules, said second attachment means comprising at least one T-shaped protrusion

20

and at least one T-shaped channel groove both integrally formed on said triangularly shaped side walls of said inclined ramp module and on said rectangularly shaped side walls of said straight ramp module, said T-shaped protrusion on one of said inclined ramp modules adapted to be slidingly, matingly moved into said T-shaped channel groove on another of said inclined ramp modules with said T-shaped protrusion on said another of said inclined ramp modules being slidingly, matingly moved into said T-shaped channel groove on said one of said inclined ramp modules, said T-shaped protrusion on one of said straight, ramp modules adapted to be slidingly, matingly moved into said T-shaped channel groove on another of said straight ramp modules with said T-shaped protrusion on said another of said straight ramp modules being slidingly, matingly moved into said T-shaped channel groove on said one of said straight ramp modules,

said T-shaped protrusions having an attaching structure at their ends which are constructed to be vertically in line when two of said ramp modules are in a stacked assembly, separate connecting means constructed to engage said attaching structures of stacked ramp modules when in line to connect said ramp modules together in the stacked condition.

23. A ramp system for forming ramp assemblies of selectively variable configurations for providing aerial lift to users of rideable wheeled recreational products including skates, skateboards and bicycles comprising ramp modules of at least two different configurations, one of said at least two ramp module configurations being an inclined ramp module having an inclined upper support surface supported on generally triangularly shaped side walls substantially over its length, said inclined ramp module having an end wall at one end of said side walls and at the upper end of said inclined surface, another of said at least two module configurations being a straight ramp module having a generally horizontal, planar upper support surface supported on generally rectangularly shaped side walls substantially over its length, said straight ramp module having end walls at opposite ends of said side walls and said straight support surface, said inclined ramp module having a bottom side engageable with a ground surface and alternatively adapted to be supported upon said planar support surface of said straight ramp module in a stacked relationship, said straight ramp module having a bottom side engageable with a ground surface, said end wall of said inclined ramp module adapted to be secured to one of said end walls of said straight ramp module for end-to-end assembly, said ramp system being formable in a stacked relationship with a first said inclined ramp module at the entrance at the ground surface connected end-to-end with one said straight ramp module at the ground surface, and including a second inclined ramp module supported on said planar support surface on said straight ramp module with said inclined surfaces of said first and second inclined ramp modules being in line, said ramp system including first attachment means for connecting selected ones of said inclined ramp modules and said straight ramp modules for end-to-end alignment, said first attachment means comprising at least one T-shaped protrusion and at least one T-shaped channel groove on said end wall of said inclined ramp module and on said end wall of said straight ramp module with the same spacing between each, said T-shaped protrusion on one of said ramp modules adapted to be slidingly, matingly moved into said T-shaped channel groove on another of said ramp modules with said T-shaped protrusion on said another of said ramp modules being slidingly matingly moved into said T-shaped channel

21

groove on said one of said ramp modules, said T-shaped protrusions having a configuration tapering from a large protrusion section on its lower end to a small protrusion section at its upper end,

said T-shaped channel groove having a configuration tapering from a small groove section at its lower end to a large groove section at its upper end,

said large protrusion section at the lower end of said T-shaped protrusion adapted to be in said small groove section at the lower end of said T-shaped channel groove with a relatively close tolerance fit and with a peripheral gap at the upper ends of said T-shaped protrusion and said T-shaped channel groove,

said T-shaped protrusion being open at its lower end, connecting means for connecting said second inclined ramp module to said straight ramp module when in a stacked assembly, said connecting means including a generally T-shaped connector having a T-shaped opening at its lower end, said T-shaped opening adapted to fit over the upper end of the T-shaped protrusion on said straight ramp module,

the upper end of said T-shaped connector adapted to fit within the opening at the lower end of said T-shaped protrusion whereby said second inclined ramp module and said straight ramp module will be secured together in the stacked condition.

24. The ramp system of claim 23 with said upper end of said T-shaped connector having a stop portion adapted to engage said lower end of said T-shaped protrusion to provide a preselected, limited amount of movement of said upper end of said T-shaped connector within said lower end of said T-shaped protrusion.

25. A ramp system for forming ramp assemblies of selectively variable configurations for providing aerial lift to users of rideable wheeled recreational products including skates, skateboards and bicycles comprising ramp modules of at least two different configurations, one of said at least two ramp module configurations being an inclined ramp module having an inclined upper support surface supported on generally triangularly shaped side walls substantially over its length, said inclined ramp module having an end wall at one end of said side walls and at the upper end of said inclined surface, another of said at least two module configurations being a straight ramp module having a generally horizontal, planar upper support surface supported on generally rectangularly shaped side walls substantially over its length, said straight ramp module having end walls at opposite ends of said side walls and said straight support surface, said inclined ramp module having a bottom side engageable with a ground surface and alternatively adapted to be supported upon said planar support surface of said straight ramp module in a stacked relationship, said straight ramp module having a bottom side engageable with a ground surface, said end wall of said inclined ramp module adapted to be secured to one of said end walls of said straight ramp module for end-to-end assembly, said ramp system being formable in a stacked relationship with a first said inclined ramp module at the entrance at the ground surface connected end-to-end with one said straight ramp module at the ground surface, and including a second inclined ramp module supported on said planar support surface on said straight ramp module with said inclined surfaces of said first and second inclined ramp modules being in line, said ramp system including first attachment means for connecting selected ones of said inclined ramp modules and said straight ramp modules for end-to-end alignment, connecting means for connecting said second inclined ramp module to

22

said straight ramp module when in a stacked assembly, said inclined ramp modules having a generally resilient lip structure extending from the lower end of said inclined surfaces,

said lip structure being of a preselected length to locate said lip structure of said second inclined ramp module proximate to the upper end of said inclined surface of said first inclined ramp module to provide a generally smooth transition between said inclined surfaces.

26. A ramp system for forming ramp assemblies of selectively variable configurations for providing aerial lift to users of rideable wheeled recreational products including skates, skateboards and bicycles comprising ramp modules of at least two different configurations, one of said at least two ramp module configurations being an inclined ramp module having an inclined upper support surface supported on generally triangularly shaped side walls substantially over its length, said inclined ramp module having an end wall at one end of said side walls and at the upper end of said inclined surface, another of said at least two module configurations being a straight ramp module having a generally horizontal, planar upper support surface supported on generally rectangularly shaped side walls substantially over its length, said straight ramp module having end walls at opposite ends of said side walls and said straight support surface, said inclined ramp module having a bottom side engageable with a ground surface and alternatively adapted to be supported upon said planar support surface of said straight ramp module in a stacked relationship, said straight ramp module having a bottom side engageable with a ground surface, said end wall of said inclined ramp module adapted to be located adjacent to one of said end walls of said straight ramp module for end-to-end assembly,

the longitudinal length of said triangularly shaped side walls of said inclined ramp module and the longitudinal length of said straight ramp module being substantially the same and the transverse width of said inclined ramp module and said straight ramp module being substantially the same to facilitate location of said bottom side of said inclined ramp module in a stacked aligned location upon said planar support surface of said straight ramp module,

said end wall of said inclined ramp module being substantially of the same size as said end walls of said straight ramp module to facilitate end-to-end location and alignment,

said ramp system formed in a stacked relationship with a first said inclined ramp module at the entrance at the ground surface connected end-to-end with one said straight ramp module at the ground surface, and including a second inclined ramp module supported on said planar support surface on said straight ramp module with said inclined surfaces of said first and second inclined ramp modules being in line, said ramp system including first attachment means for connecting selected ones of said inclined ramp modules and said straight ramp modules for end-to-end alignment, said first attachment means comprising at least one T-shaped protrusion and at least one T-shaped channel groove on said end wall of said inclined ramp module and on said one end wall of said straight ramp module with the same spacing between each, said T-shaped protrusion on one of said ramp modules adapted to be slidingly, matingly moved into said T-shaped channel groove on another of said ramp modules with said T-shaped protrusion on said another of said ramp modules being slidingly matingly moved into said T-shaped channel

23

groove on said one of said ramp modules, said T-shaped protrusions having a configuration tapering from a large protrusion section on its lower end to a small protrusion section at its upper end,  
 said T-shaped channel groove having a configuration tapering from a small groove section at its lower end to a large groove section at its upper end,  
 said large protrusion section at the lower end of said T-shaped protrusion adapted to be in said small groove section at the lower end of said T-shaped channel groove with a relatively close tolerance fit and with a peripheral gap at the upper ends of said T-shaped protrusion and said T-shaped channel groove,  
 said T-shaped protrusion being open at its lower end, connecting means for connecting said second inclined ramp module to said straight ramp module when in a stacked assembly, said connecting means including a connector having an opening at its lower end, said opening adapted to fit over the upper end of the T-shaped protrusion on said straight ramp module,  
 the upper end of said connector adapted to fit within the opening at the lower end of said T-shaped protrusion whereby said second inclined ramp module and said straight ramp module will be secured together in the stacked condition.

27. A ramp system for forming ramp assemblies of selectively variable configurations for providing aerial lift to users of rideable wheeled recreational products including skates, skateboards and bicycles comprising ramp modules of at least two different configurations, one of said at least two ramp module configurations being an inclined ramp module having an inclined upper support surface supported on generally triangularly shaped side walls substantially over its length, said inclined ramp module having an end wall at one end of said side walls and at the upper end of said inclined surface, another of said at least two module configurations being a straight ramp module having a generally horizontal, planar upper support surface supported on generally rectangularly shaped side walls substantially over its length, said straight ramp module having end walls at opposite ends of said side walls and said straight support surface, said inclined ramp module having a bottom side engageable with a ground surface and alternatively adapted to be supported upon said planar support surface of said straight ramp module in a stacked relationship, said straight ramp module having a bottom side engageable with a ground surface, said end wall of said inclined ramp module adapted to be located adjacent to one of said end walls of said straight ramp module for end-to-end assembly,

the longitudinal length of said triangularly shaped side walls of said inclined ramp module and the longitudinal length of said straight ramp module being substantially the same and the transverse width of said inclined ramp module and said straight ramp module being substantially the same to facilitate location of said bottom side of said inclined ramp module in a stacked aligned location upon said planar support surface of said straight ramp module,

said end wall of said inclined ramp module being substantially of the same size as said end walls of said straight ramp module to facilitate end-to-end location and alignment, said ramp system including a foot member which is a strip-like generally resilient structure adapted to be located on at least one of the edges including edges at said bottom side of said inclined ramp module and said bottom side of said straight module for contacting the ground surface to inhibit slippage,

24

said edges including the edges of said lower extremities of said triangularly shaped side walls and the edges at said bottom portion of said some of said ribs of said inclined ramp module and the edges of said lower extremities of said rectangularly shaped side walls and the edges at said bottom portion of said some of said ribs of said straight ramp module,

said foot member when applied to said at least one of the edges defining a channel portion when applied with side sections accepting said edges of varying thickness of said lower extremities of said triangularly shaped side walls of said inclined ramp module and said some of said ribs of said inclined ramp module and of said straight ramp module, said channel portion as applied having an opening at its upper end with said side sections being adapted to at least partially close said opening and adapted to be apart when said edges of said inclined ramp module and of said straight ramp module are moved into said channel portion and to close to grip said edges to retain said foot member to said at least one of said edges.

28. A ramp system for forming ramp assemblies of selectively variable configurations for providing aerial lift to users of rideable wheeled recreational products including skates, skateboards and bicycles comprising ramp modules of at least two different configurations, one of said at least two ramp module configurations being an inclined ramp module having an inclined upper support surface supported on generally triangularly shaped side walls substantially over its length, said inclined ramp module having an end wall at one end of said side walls and at the upper end of said inclined surface, another of said at least two module configurations being a straight ramp module having a generally horizontal, planar upper support surface supported on generally rectangularly shaped side walls substantially over its length, said straight ramp module having end walls at opposite ends of said side walls and said straight support surface, said inclined ramp module having a bottom side engageable with a ground surface and alternatively adapted to be supported upon said planar support surface of said straight ramp module in a stacked relationship, said straight ramp module having a bottom side engageable with a ground surface and alternatively adapted to be supported on said planar support surface of another of said straight ramp modules in a stacked relationship, said end wall of said inclined ramp module adapted to be secured to one of said end walls of said straight ramp module for end-to-end assembly, either one of said end walls at one end of said straight ramp module adapted to be secured to an end wall of another of said straight module for end-to-end assembly,

first attachment means for connecting selected ones of said inclined ramp modules and said straight ramp modules for end-to-end alignment, said first attachment means comprising at least one T-shaped protrusion and at least one T-shaped channel groove on said end wall of said inclined ramp module and on said end wall of said straight ramp module with the same spacing between each, said T-shaped protrusion on one of said ramp modules adapted to be slidingly, matingly moved into said T-shaped channel groove on another of said ramp modules with said T-shaped protrusion on said another of said ramp modules being slidingly matingly moved into said T-shaped channel groove on said one of said ramp modules, said T-shaped protrusions having a configuration tapering from a large protrusion section on its lower end to a small protrusion section at its upper end, said T-shaped channel groove having a

25

configuration tapering from a small groove section at its lower end to a large groove section at its upper end, said large protrusion section at the lower end of said T-shaped protrusion adapted to be located in said small groove section at the lower end of said T-shaped channel groove with a relatively close tolerance fit.

29. A ramp system for forming ramp assemblies of selectively variable configurations for providing aerial lift to users of rideable wheeled recreational products including skates, skateboards and bicycles comprising ramp modules of at least two different configurations, one of said at least two ramp module configurations being an inclined ramp module having an inclined upper support surface supported on generally triangularly shaped side walls substantially over its length, said inclined ramp module having an end wall at one end of said side walls and at the upper end of said inclined surface, another of said at least two module configurations being a straight ramp module having a generally horizontal, planar upper support surface supported on generally rectangularly shaped side walls substantially over its length, said straight ramp module having end walls at opposite ends of said side walls and said straight support surface, said inclined ramp module having a bottom side engageable with a ground surface and alternatively adapted to be supported upon said planar support surface of said straight ramp module in a stacked relationship, said straight ramp module having a bottom side engageable with a ground surface and alternatively adapted to be supported on said planar support surface of another of said straight ramp modules in a stacked relationship, said end wall of said inclined ramp module adapted to be secured to one of said end walls of said straight ramp module for end-to-end assembly, either one of said end walls at one end of said straight ramp module adapted to be secured to the opposite end wall of another of said straight module for end-to-end assembly, said ramp being formable in a stacked relationship with a first said inclined ramp module at the entrance at the ground surface connected end-to-end with one said straight ramp module at the ground surface, and including a second inclined ramp module supported on said planar support surface on said straight ramp module with said inclined surfaces of said first and second inclined ramp modules being in line, said ramp system including first attachment means for connecting selected ones of said inclined ramp modules and said straight ramp modules for end-to-end alignment, said first attachment means comprising at least one T-shaped protrusion and at least one T-shaped channel groove on said end wall of said inclined ramp module and on said one end wall of said straight ramp module with the same spacing between each, said T-shaped protrusion on one of said ramp modules adapted to be slidingly, matingly moved into said T-shaped channel groove on another of said ramp modules with said T-shaped protrusion on said another of said ramp modules being slidingly matingly moved into said T-shaped channel groove on said one of said ramp modules, said T-shaped protrusions having a configuration tapering from a large protrusion section on its lower end to a small protrusion section at its upper end,

said T-shaped channel groove having a configuration tapering from a small groove section at its lower end to a large groove section at its upper end,

said large protrusion section at the lower end of said T-shaped protrusion adapted to be located in said small groove section at the lower end of said T-shaped channel groove with a relatively close tolerance fit and with a peripheral gap at the upper ends of said T-shaped protrusion and said T-shaped channel groove,

26

said T-shaped protrusion being open at its lower end, connecting means for connecting said second inclined ramp module to said straight ramp module when in a stacked assembly, said connecting means including a generally T-shaped connector having a T-shaped opening at its lower end, said T-shaped opening adapted to fit over the upper end of the T-shaped protrusion on said straight ramp module,

the upper end of said T-shaped connector adapted to fit within the opening at the lower end of said T-shaped protrusion whereby said second inclined ramp module and said straight ramp module will be secured together in the stacked condition.

30. A ramp system for forming ramp assemblies of selectively variable configurations for providing aerial lift to users of rideable wheeled recreational products including skates, skateboards and bicycles comprising at least one ramp module of a configuration being an inclined ramp module being of a hollow construction with an inclined upper support surface supported on generally triangularly shaped side walls substantially over its length, said inclined ramp module having an end wall at one end of said side walls and at the upper end of said inclined surface, said inclined ramp module having a bottom side engageable with a ground surface, said end wall of said inclined ramp module adapted to be secured to an end wall of another ramp module of a hollow construction for end-to-end assembly, attachment means for selectively connecting said inclined ramp module and said other ramp module for end-to-end alignment, said attachment means comprising at least one T-shaped protrusion integrally formed on said end wall of said inclined ramp module and an end wall of said other ramp module and at least one T-shaped channel groove integrally formed on said end wall of said inclined ramp module and the end wall of said other ramp module, said T-shaped protrusions adapted to be slidingly, matingly moved into said T-shaped channel grooves, said T-shaped protrusions having a generally hollow construction opening to the inside of said modules and being closed at the top.

31. A ramp system for forming ramp assemblies of selectively variable configurations for providing aerial lift to users of rideable wheeled recreational products including skates, skateboards and bicycles comprising at least one ramp module of a configuration being an inclined ramp module having an inclined upper support surface supported on generally triangularly shaped side walls substantially over its length, said inclined ramp module having an end wall at one end of said side walls and at the upper end of said inclined surface, said inclined ramp module having a bottom side engageable with a ground surface, said end wall of said inclined ramp module adapted to be secured to an end wall of another ramp module for end-to-end assembly, attachment means for selectively connecting said inclined ramp module and said other ramp module for end-to-end alignment, said attachment means comprising at least one T-shaped protrusion integrally formed on one of said end wall of said inclined ramp module and an end wall of said other ramp module and at least one T-shaped channel groove integrally formed on the other one of said end wall of said inclined ramp module and the end wall of said other ramp module, said T-shaped protrusion adapted to be slidingly, matingly moved into said T-shaped channel groove, said inclined ramp module being of a generally hollow structure with said triangularly shaped side walls and end wall being of a relatively thin wall thickness, the lower extremities of said triangularly shaped side walls and end wall defining the bottom side of said inclined ramp module, said upper

support surface being substantially uniformly flat over its length, said inclined ramp module having a plurality of generally flat internal ribs extending longitudinally and transversely across the bottom of said flat upper support surface at spaced intervals with substantially no distortion of said flat upper support surface, at least some of said internal ribs having end sections with a bottom portion extending inwardly and downwardly to substantially the same location as the extremities of said triangularly shaped side walls and said end wall to provide further support for said flat upper surface and said walls and end wall of said inclined ramp module at said bottom side.

**32.** A ramp system for forming ramp assemblies of selectively variable configurations for providing aerial lift to users of rideable wheeled recreational products including skates, skateboards and bicycles comprising at least one ramp module of a configuration being an inclined ramp module having an inclined upper support surface supported on generally triangularly shaped side walls substantially over its length, said inclined ramp module having an end wall at one end of said side walls and at the upper end of said inclined surface, said inclined ramp module having a bottom side engageable with a ground surface, said end wall of said inclined ramp module adapted to be secured to an end wall of another ramp module for end-to-end assembly, attachment means for selectively connecting said inclined ramp module and said other ramp module for end-to-end alignment, said attachment means comprising at least one T-shaped protrusion integrally formed on one of said end wall of said inclined ramp module and an end wall of said other ramp module and at least one T-shaped channel groove integrally formed on the other one of said end wall of said inclined ramp module and the end wall of said other ramp module, said T-shaped protrusion adapted to be slidably, matingly moved into said T-shaped channel groove, said T-shaped protrusions having a configuration tapering from a large protrusion section on its lower end to a small protrusion section at its upper end, said T-shaped channel groove having a configuration tapering from a small groove section at its lower end to a large groove section at its upper end, said large protrusion section at the lower end of said T-shaped protrusion adapted to be located in said small groove section at the lower end of said T-shaped channel groove with a relatively close tolerance fit.

**33.** A ramp system for forming ramp assemblies of selectively variable configurations for providing aerial lift to users of rideable wheeled recreational products including skates, skateboards and bicycles comprising a plurality of ramp modules including at least one ramp module of a configuration being an inclined ramp module having an inclined upper support surface supported on generally triangularly shaped side walls substantially over its length, said inclined ramp module having an end wall at one end of said side walls and at the upper end of said inclined surface, said inclined ramp module having a bottom side engageable with a ground surface, said end wall of said inclined ramp module adapted to be secured to an end wall of another ramp module for end-to-end assembly, attachment means for selectively connecting said inclined ramp module and said other ramp module for end-to-end alignment, said attachment means comprising at least one first attachment structure integrally formed on one of said end wall of said inclined ramp module and on an end wall of said other ramp module and at least one second attachment structure integrally formed on the other one of said end wall of said inclined ramp module and the end wall of said other ramp module, said first and second attachment structures being of

different interfitting constructions with said first attachment structure adapted to be engaged with said second attachment structure to lockingly secure said ramp modules together with said inclined ramp module being of a generally hollow structure with said triangularly shaped side walls and end wall being of a relatively thin wall thickness, the lower extremities of said triangularly shaped side walls and end wall defining the bottom side of said inclined ramp module, said upper support surface being substantially uniformly flat over its length, said inclined ramp module having a plurality of generally flat internal ribs extending longitudinally and transversely across the bottom of said flat upper support surface at spaced intervals with substantially no distortion of said flat upper support surface, at least some of said internal ribs having end sections with a bottom portion extending inwardly and downwardly to substantially the same location as the extremities of said triangularly shaped side walls and said end wall to provide further support for said flat upper support surface and said side walls and end wall of said inclined ramp module at said bottom side.

**34.** A ramp system for forming ramp assemblies for providing aerial lift to users of rideable wheeled recreational products including skates, skateboards and bicycles comprising ramp modules of at least two different configurations, one of said at least two ramp module configurations being an inclined ramp module having an inclined upper support surface supported on generally triangularly shaped side walls substantially over its length,

said inclined ramp module having an end wall at one end of said side walls and at the upper end of said inclined surface,

another of said at least two module configurations being a straight ramp module having a generally horizontal, planar upper support surface supported on generally rectangularly shaped side walls substantially over its length,

said straight ramp module having end walls at opposite ends of said side walls and said straight support surface, said inclined ramp module having a bottom side engageable with a ground surface and alternatively adapted to be supported upon said planar support surface of said straight ramp module in a stacked relationship, said straight ramp module having a bottom side engageable with a ground surface, said end wall of said inclined ramp module adapted to be secured to one of said end walls of said straight ramp module for end-to-end assembly,

said ramp system being formable in a stacked relationship with a first said inclined ramp module at the entrance at the ground surface connected end-to-end with said straight ramp module at the ground surface, and including a second inclined ramp module supported on said planar support surface on said straight ramp module with said inclined surfaces of said first and second inclined ramp modules being in line,

said ramp system including first attachment means for connecting selected ones of said inclined ramp modules and said straight ramp modules for end-to-end alignment,

said ramp system including second attachment means for connecting said inclined ramp modules side-by-side and for connecting said straight ramp modules side-by-side,

said second attachment means comprising at least one T-shaped protrusion and at least one T-shaped channel groove on said side wall of said inclined ramp module

29

and on said side wall of said straight ramp module with the same spacing between each,

said T-shaped protrusion on said second inclined ramp module adapted to be in line with said T-shaped protrusion on said straight ramp module when supported on said upper support surface of said straight ramp module, said T-shaped protrusion on said another of said ramp modules being slidably matingly movable into said T-shaped channel groove on said one of said ramp modules,

said T-shaped protrusions having a configuration tapering from a large protrusion section on its lower end to a small protrusion section at its upper end, said T-shaped channel groove having a configuration tapering from a small groove section at its lower end to a large groove section at its upper end, said large protrusion section at the lower end of said T-shaped protrusion adapted to be located in said small groove section at the lower end of said T-shaped channel groove with a relatively close tolerance fit and with a peripheral gap at the upper ends of said T-shaped protrusion and said T-shaped channel groove, said T-shaped protrusion being open at its lower end,

connecting means for connecting said second inclined ramp module to said straight ramp module when in a stacked assembly, said connecting means including a connector having an opening at its lower end, said opening adapted to fit over the upper end of the T-shaped protrusion on said straight ramp module, the upper end of said connector adapted to fit within the opening at the lower end of said T-shaped protrusion on said second inclined ramp module whereby said second inclined ramp module and said straight ramp module will be secured together in the stacked condition.

**35.** The ramp system of claim **34** with said first attachment means comprising at least one T-shaped protrusion and at least one T-shaped channel groove on said end wall of said inclined ramp module and on said end walls of said straight ramp module with the same spacing between each,

said T-shaped protrusion on one of said ramp modules adapted to be slidably, matingly moved into said T-shaped channel groove on another of said ramp modules with said T-shaped protrusion on said another of said ramp modules being slidably matingly moved into said T-shaped channel groove on said one of said ramp modules,

said T-shaped protrusions having a configuration tapering from a large protrusion section on its lower end to a small protrusion section at its upper end,

said T-shaped channel groove having a configuration tapering from a small groove section at its lower end to a large groove section at its upper end, said large protrusion section at the lower end of said T-shaped protrusion adapted to be in said small groove section at the lower end of said T-shaped channel groove with a relatively close tolerance fit and with a peripheral gap at the upper ends of said T-shaped protrusion and said T-shaped channel groove, said T-shaped protrusion being open at its lower end,

said T-shaped protrusion and said T-shaped channel groove on the end wall of said second inclined ramp being in line with said T-shaped protrusion and said T-shaped channel groove on the end wall of said straight ramp module when supported on said upper support surface,

said opening of said connector adapted to fit over the upper end of said T-shaped protrusion on said end wall

30

of said straight ramp module, the upper end of said connector adapted to fit within the opening at the lower end of said T-shaped protrusion on said end wall of said second inclined ramp whereby said second inclined ramp module and said straight ramp module will be secured together in the stacked condition.

**36.** The ramp system of claim **35** with said connectors of said connecting means being T-shaped with said opening at said lower end being T-shaped and adapted to fit over the upper end of the T-shaped protrusions on said inclined and straight ramp modules and with said upper ends of said T-shaped protrusions of said inclined and straight ramp modules adapted to fit within the opening at said lower ends of said T-shaped protrusions whereby said second inclined ramp module and said straight ramp module will be secured together in the stacked condition.

**37.** A modular system for forming modular assemblies of selectively variable configurations for providing support to users comprising a plurality of straight modules each having a generally horizontal, planar upper support surface supported on generally rectangularly shaped side walls substantially over its length, said straight modules having generally rectangularly shaped end walls at opposite ends of said side walls and said straight support surface, said straight modules each having a bottom side engageable with a ground surface, said end walls of said straight modules adapted to be secured to said end walls of another of said straight modules for end-to-end assembly, said side walls of said straight modules adapted to be secured to said side walls of another of said straight modules for side-by-side assembly, attachment means for selectively connecting said straight modules for end-to-end alignment and for side-by-side alignment, said attachment means comprising at least one T-shaped protrusion and at least one T-shaped channel groove both integrally formed on said end walls and said side walls of said straight modules with the same spacing between each, said T-shaped protrusions on one of said straight modules adapted to be slidably, matingly moved into said T-shaped channel grooves on another of said straight modules with said T-shaped protrusion on said another of said straight modules being slidably, matingly moved into said T-shaped channel groove on said one of said straight modules, said T-shaped protrusion and said T-shaped channel groove being of a reverse tapered construction with said T-shaped protrusion partially engaging said T-shaped channel groove with a preselected close fit at their bottom surfaces when assembled.

**38.** The modular system of claim **37** with said bottom side being alternatively adapted to be supported on said planar support surface of another of said straight modules in a stacked relationship, connecting means for connecting said straight modules together when in a stacked assembly, said connecting means operable with the T-shaped protrusions on said straight modules when stacked whereby said straight modules will be secured together in the stacked condition.

**39.** The modular system of claim **38**, with said straight module being of a generally hollow structure with said generally rectangularly shaped side walls and said end walls at opposite ends being of a relatively thin wall thickness, the lower extremities of said generally rectangularly shaped side walls and said end walls defining the bottom side of said straight module, said straight module having a plurality of longitudinally and transversely extending generally flat internal ribs, at least some of said internal ribs having at least a bottom portion extending downwardly to substantially the same location as the extremities of said generally rectangularly shaped side walls and said end walls to provide further



31

support for said straight module at said bottom side, at least some of said internal ribs extending generally inwardly from said planar upper support surface with substantially no distortion of said planar upper support surface.

40. The modular system of claim 37 being formed as a ramped system and including an inclined module having an inclined upper support surface supported on generally triangularly shaped side walls, said inclined module having an end wall at one end of said side walls and at the upper end of said inclined surface, said inclined module having a bottom side engageable with a ground surface, said end wall of said inclined module adapted to be connected to one of said walls of said straight module, said end wall of said inclined module and said walls of said straight module being of substantially the same vertical height, second attachment means for connecting said inclined module and said straight modules, said second attachment means comprising at least one T-shaped protrusion and at least one T-shaped channel groove both integrally formed on said end wall of said inclined module with the same spacing between each as said T-shaped protrusion and said T-shaped channel groove on said straight module, said T-shaped protrusion on said inclined module adapted to be slidingly, matingly moved into said T-shaped channel groove on said straight module with said T-shaped protrusion on said straight module being slidingly, matingly moved into said T-shaped channel groove on said inclined module.

41. The modular system of claim 37 with said walls of said straight module having a vertical height of no less than around 12 inches.

42. A modular system for forming modular assemblies of selectively variable configurations for providing support to users comprising a plurality of straight modules each having a generally horizontal, planar upper support surface supported on generally rectangularly shaped side walls substantially over its length, said straight modules having generally rectangularly shaped end walls at opposite ends of said side walls and said straight support surface, said straight modules each having a bottom side engageable with a ground surface, said end walls of said straight modules adapted to be secured to said end walls of another of said straight modules for end-to-end assembly, said side walls of said straight modules adapted to be secured to side walls of another of said straight modules for side-by-side assembly, attachment means for selectively connecting said straight modules for end-to-end alignment and for side-by-side alignment, said attachment means comprising at least one T-shaped protrusion and at least one T-shaped channel groove both integrally formed on said end walls and said side walls of said straight modules with the same spacing between each, said T-shaped protrusions on one of said straight modules adapted to be slidingly, matingly moved into said T-shaped channel grooves on another of said straight modules with said T-shaped protrusion on said another of said straight modules being slidingly matingly moved into said T-shaped channel groove on said one of said straight modules,

said T-shaped protrusions having a configuration tapering from a large protrusion section on its lower end to a small protrusion section at its upper end, said T-shaped channel groove having a configuration tapering from a small groove section at its lower end to a large groove section at its upper end,

said large protrusion section at the lower end of said T-shaped protrusion adapted to be located in said small groove section at the lower end of said T-shaped channel groove with a relatively close tolerance fit.

43. The modular system of claim 42 with said bottom side of said straight modules being alternatively adapted to be

32

supported on said planar support surface of another of said straight modules in a stacked relationship,

said large protrusion section at the lower end of said T-shaped protrusion when located in said small groove section at the lower end of said T-shaped channel groove with a relatively close tolerance fit having a peripheral gap at the upper ends of said T-shaped protrusion and said T-shaped channel groove,

said T-shaped protrusion being open at its lower end,

connecting means for connecting said straight modules when in a stacked assembly, said connecting means including a generally T-shaped connector having a T-shaped opening at its lower end, said T-shaped opening adapted to fit over the upper end of the T-shaped protrusion on said straight module,

the upper end of said T-shaped connector adapted to fit within the opening at the lower end of said T-shaped protrusion whereby said straight modules will be secured together in the stacked condition.

44. The modular system of claim 43 with said straight module being of a generally hollow structure with said generally rectangularly shaped sidewalls and said end walls at opposite ends being of a relatively thin wall thickness, the lower extremities of said generally rectangularly shaped side walls and said end walls defining the bottom side of said straight module, said straight module having a plurality of longitudinally and transversely extending internal ribs, at least some of said internal ribs having at least a bottom portion extending downwardly to substantially the same location as the extremities of said generally rectangularly shaped side walls and said end walls to provide further support for said straight module at said bottom side, at least some of said internal ribs extending generally inwardly from said planar upper support surface.

45. The modular system of claim 42 being formed as a ramped system and including an inclined module having an inclined upper support surface supported on generally triangularly shaped side walls, said inclined module having an end wall at one end of said side walls and at the upper end of said inclined surface, said inclined module having a bottom side engageable with a ground surface, said end wall of said inclined module adapted to be connected to one of said walls of said straight module, said end wall of said inclined module and said walls of said straight module being of substantially the same vertical height, second attachment means for connecting said inclined module and said straight modules, said second attachment means comprising at least one T-shaped protrusion and at least one T-shaped channel groove both integrally formed on said end wall of said inclined module with the same spacing between each as said T-shaped protrusion and said T-shaped channel groove on said straight module, said T-shaped protrusion on said inclined module adapted to be slidingly, matingly moved into said T-shaped channel groove on said straight module with said T-shaped protrusion on said straight module being slidingly, matingly moved into said T-shaped channel groove on said inclined module.

46. The modular system of claim 42 being formed as a ramped system and including an inclined module having an inclined upper support surface supported on generally triangularly shaped side walls, said inclined module having a bottom side adapted to be supported upon said planar support surface of said straight module in a stacked relationship,

the longitudinal length of said triangularly shaped side walls of said inclined module and the longitudinal

33

length of said straight module being substantially the same to facilitate location of said bottom side of said inclined module in a stacked aligned location upon said planar support surface of said straight module, said end wall of said inclined module and said walls of said straight module being of substantially the same vertical height, second attachment means comprising at least one T-shaped protrusion and at least one T-shaped channel groove on said walls of said inclined module with the same spacing between each as said T-shaped protrusion and said T-shaped channel groove on said straight modules,

said T-shaped protrusions having a configuration tapering from a large protrusion section on its lower end to a small protrusion section at its upper end,

said T-shaped channel groove having a configuration tapering from a small groove section at its lower end to a large groove section as its upper end,

said large protrusion section at the lower end of said T-shaped protrusion adapted to be in said small groove

34

section at the lower end of said T-shaped channel groove with a relatively close tolerance fit and with a peripheral gap at the upper ends of said T-shaped protrusion and said T-shaped channel groove,

said T-shaped protrusion being open at its lower end, connecting means for connecting said inclined module to said straight module when in a stacked assembly, said connecting means including a connector having an opening at its lower end, said opening adapted to fit over the upper end of the T-shaped protrusion on said straight module,

the upper end of said connector adapted to fit within the opening at the lower end of said T-shaped protrusion whereby said inclined module and said straight module will be secured together in the stacked condition.

47. The modular system of claim 42 with said walls of said straight module having a vertical height of no less than around 12 inches.

\* \* \* \* \*