



US 20090162259A1

(19) **United States**

(12) **Patent Application Publication**  
Nowak et al.

(10) **Pub. No.: US 2009/0162259 A1**

(43) **Pub. Date: Jun. 25, 2009**

(54) **HIGH EFFICIENCY UV CURING SYSTEM**

**Related U.S. Application Data**

(76) Inventors: **Thomas Nowak**, Sunnyvale, CA (US); **Juan Carlos Rocha-Alvarez**, Cupertino, CA (US); **Andrzej Kaszuba**, San Jose, CA (US); **Scott A. Hendrickson**, Brentwood, CA (US); **Dustin W. Ho**, Fremont, CA (US); **Sanjeev Baluja**, San Francisco, CA (US); **Tom Cho**, Palo Alto, CA (US); **Josephine Chang**, Sunnyvale, CA (US); **Hichem M'saad**, Santa Clara, CA (US)

(63) Continuation of application No. 11/124,908, filed on May 9, 2005.

**Publication Classification**

(51) **Int. Cl.**  
**B01J 19/08** (2006.01)  
(52) **U.S. Cl.** ..... **422/186.3**  
(57) **ABSTRACT**

An ultraviolet (UV) cure chamber enables curing a dielectric material disposed on a substrate and in situ cleaning thereof. A tandem process chamber provides two separate and adjacent process regions defined by a body covered with a lid having windows aligned respectively above each process region. One or more UV sources per process region that are covered by housings coupled to the lid emit UV light directed through the windows onto substrates located within the process regions. The UV sources can be an array of light emitting diodes or bulbs utilizing a source such as microwave or radio frequency. The UV light can be pulsed during a cure process. Using oxygen radical/ozone generated remotely and/or in-situ accomplishes cleaning of the chamber. Use of lamp arrays, relative motion of the substrate and lamp head, and real-time modification of lamp reflector shape and/or position can enhance uniformity of substrate illumination.

**Correspondence Address:**

**PATTERSON & SHERIDAN, LLP - - APPM/TX**  
**3040 POST OAK BOULEVARD, SUITE 1500**  
**HOUSTON, TX 77056 (US)**

(21) Appl. No.: **12/393,851**

(22) Filed: **Feb. 26, 2009**

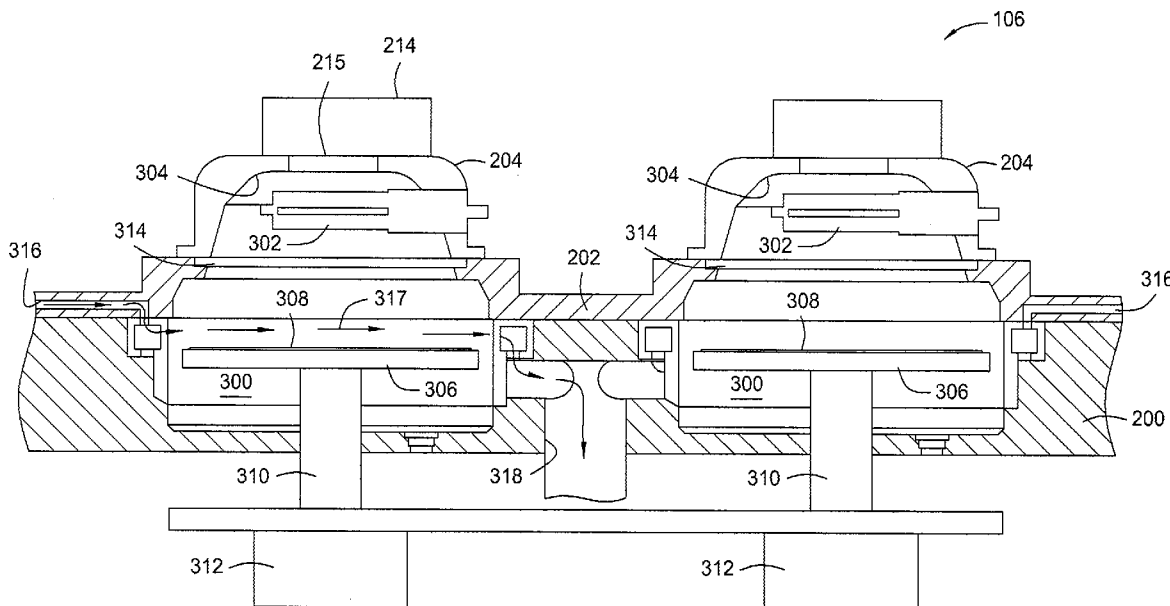

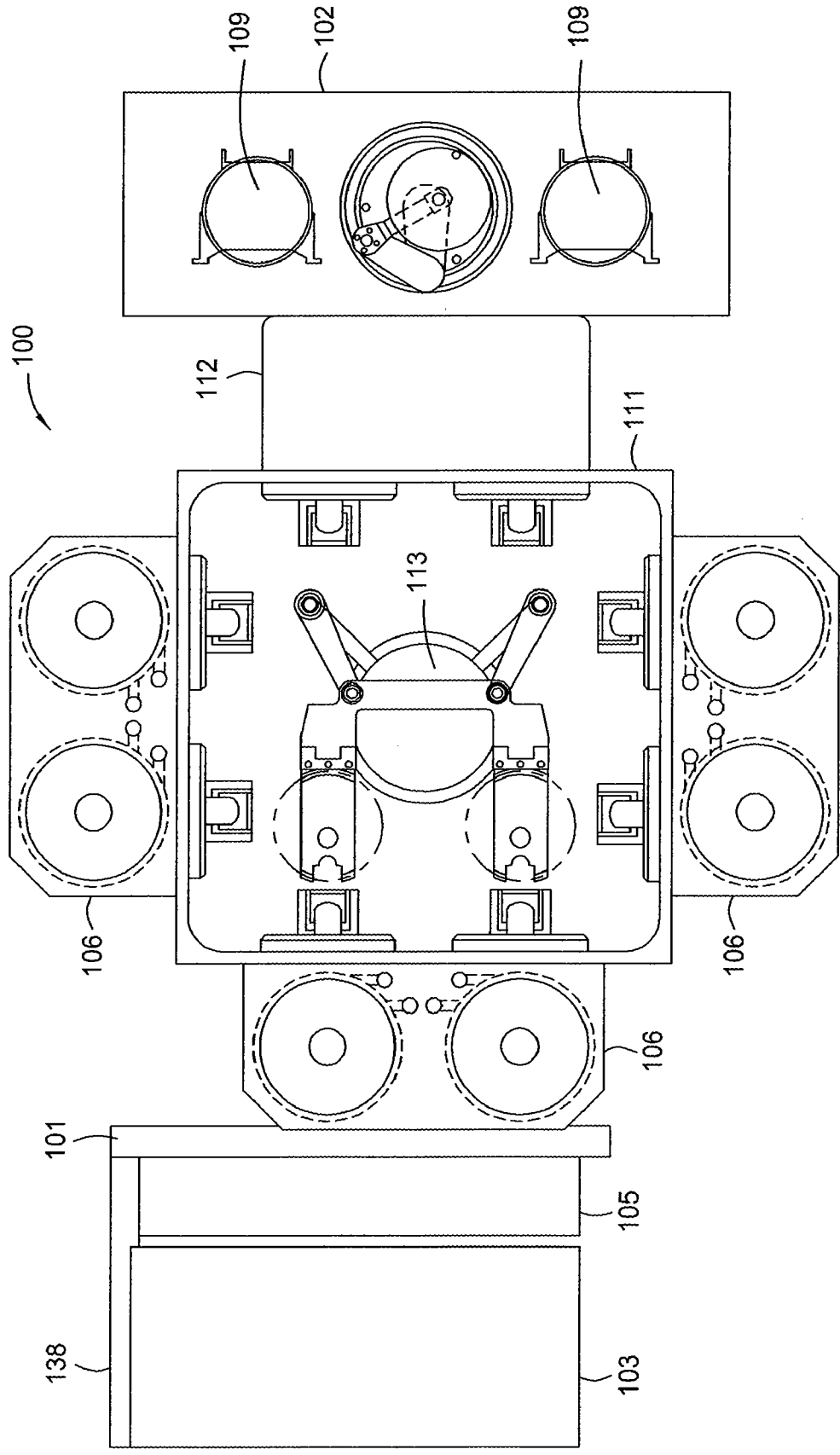

FIG. 1

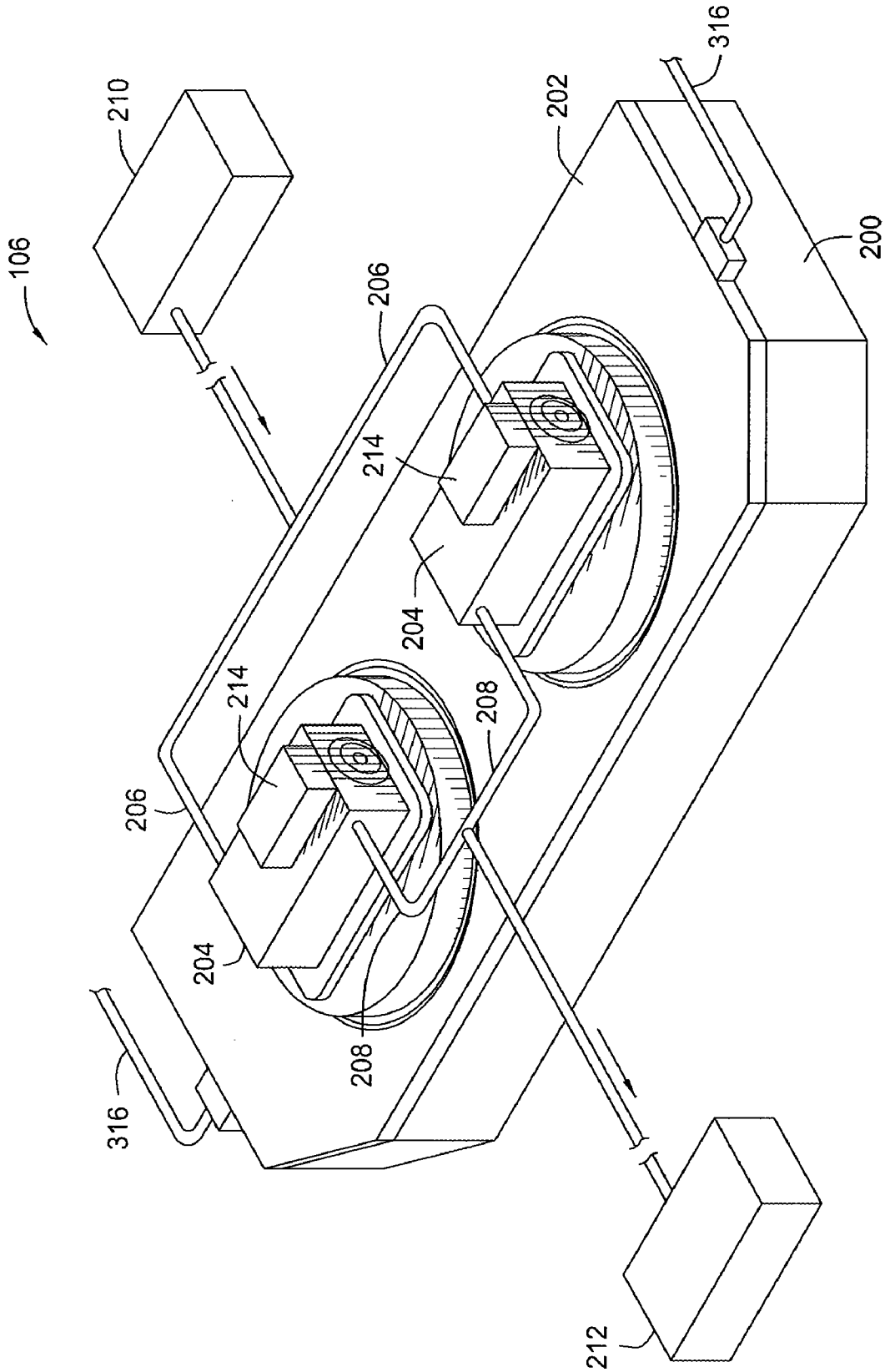

FIG. 2

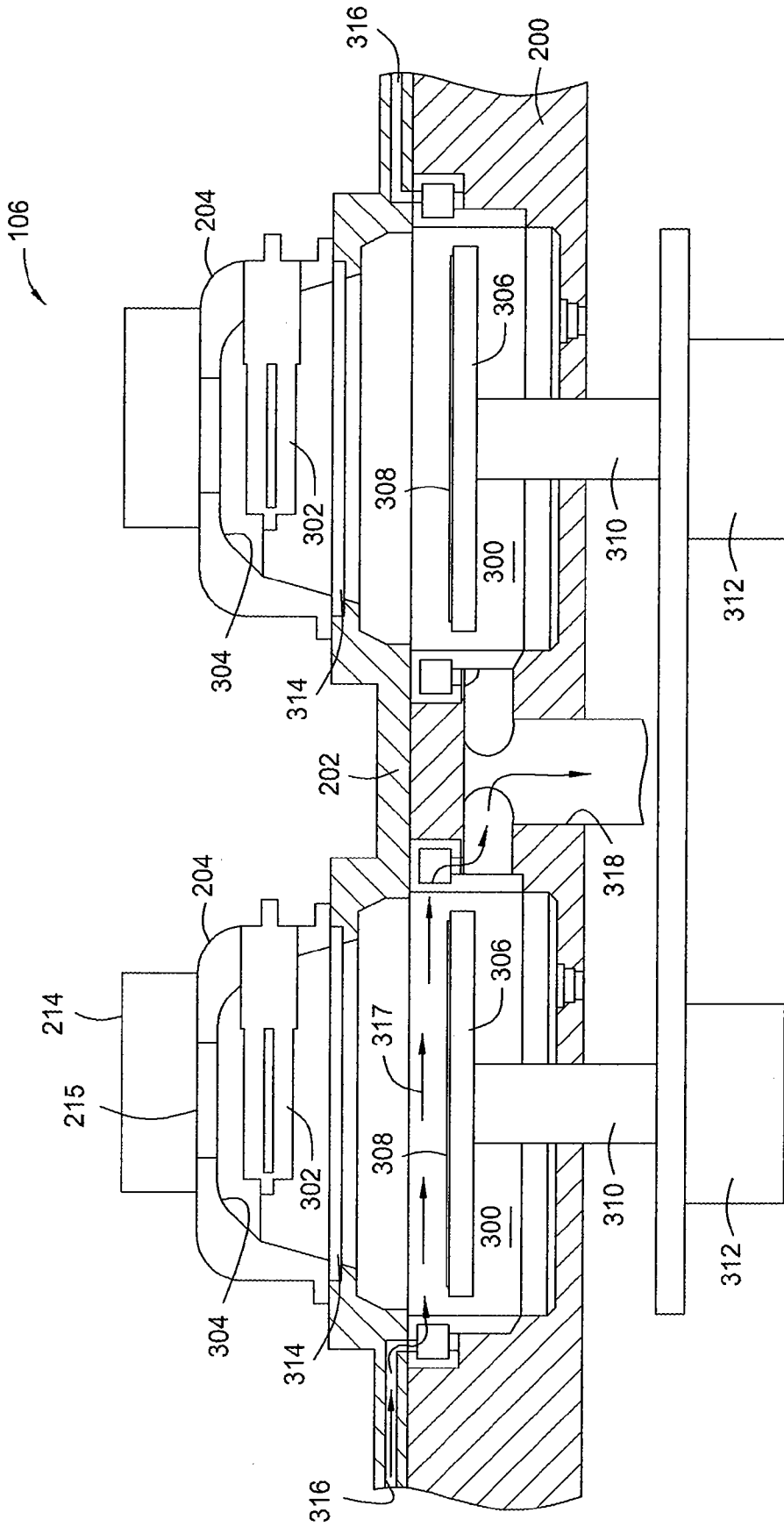

FIG. 3

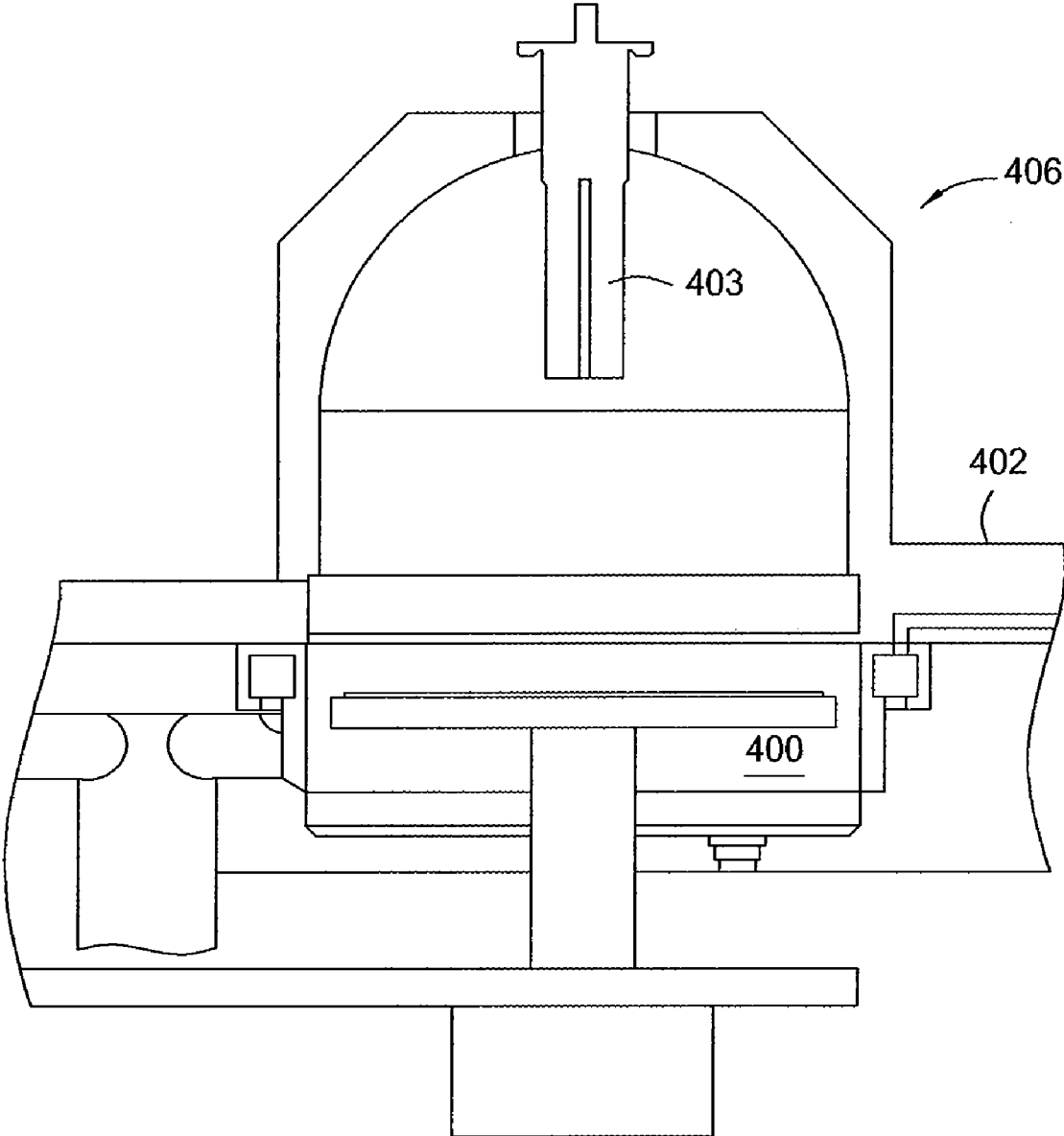

FIG. 4

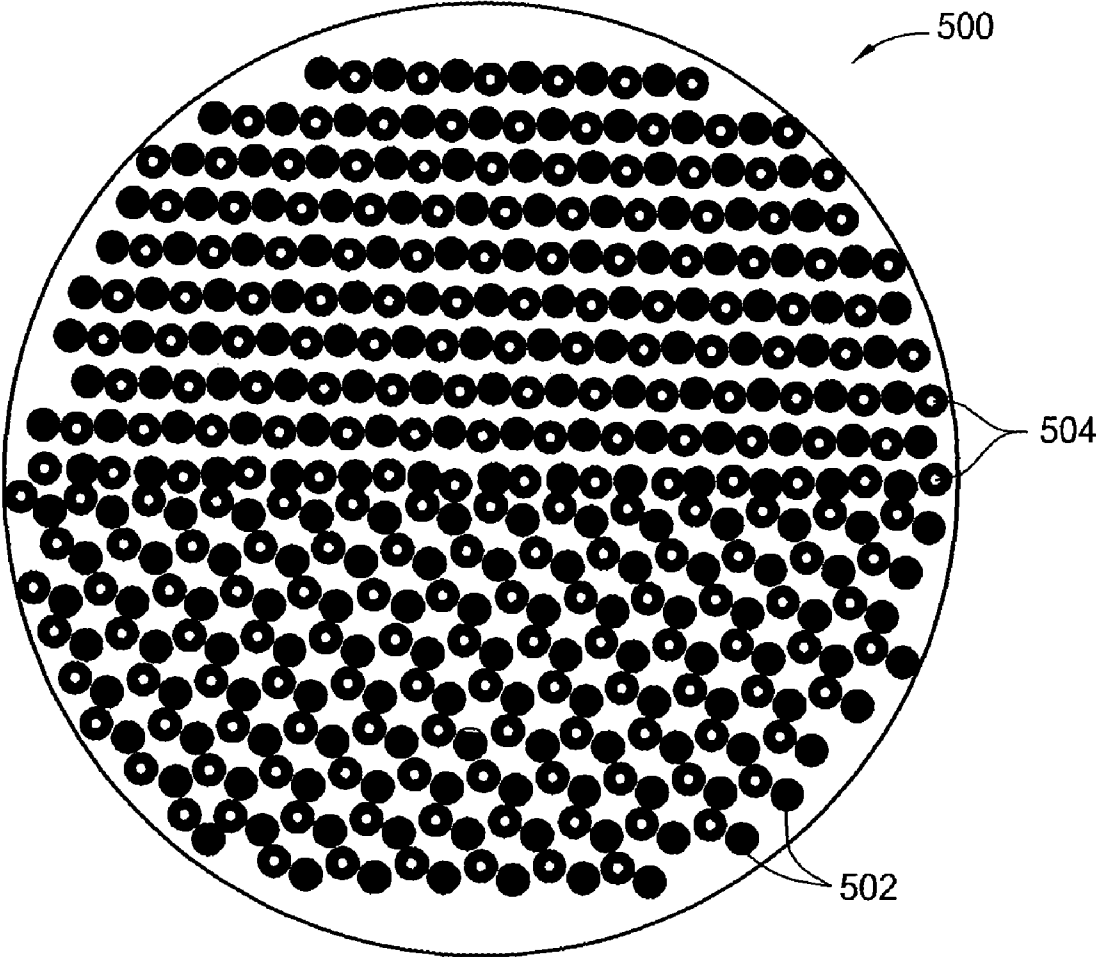

FIG. 5

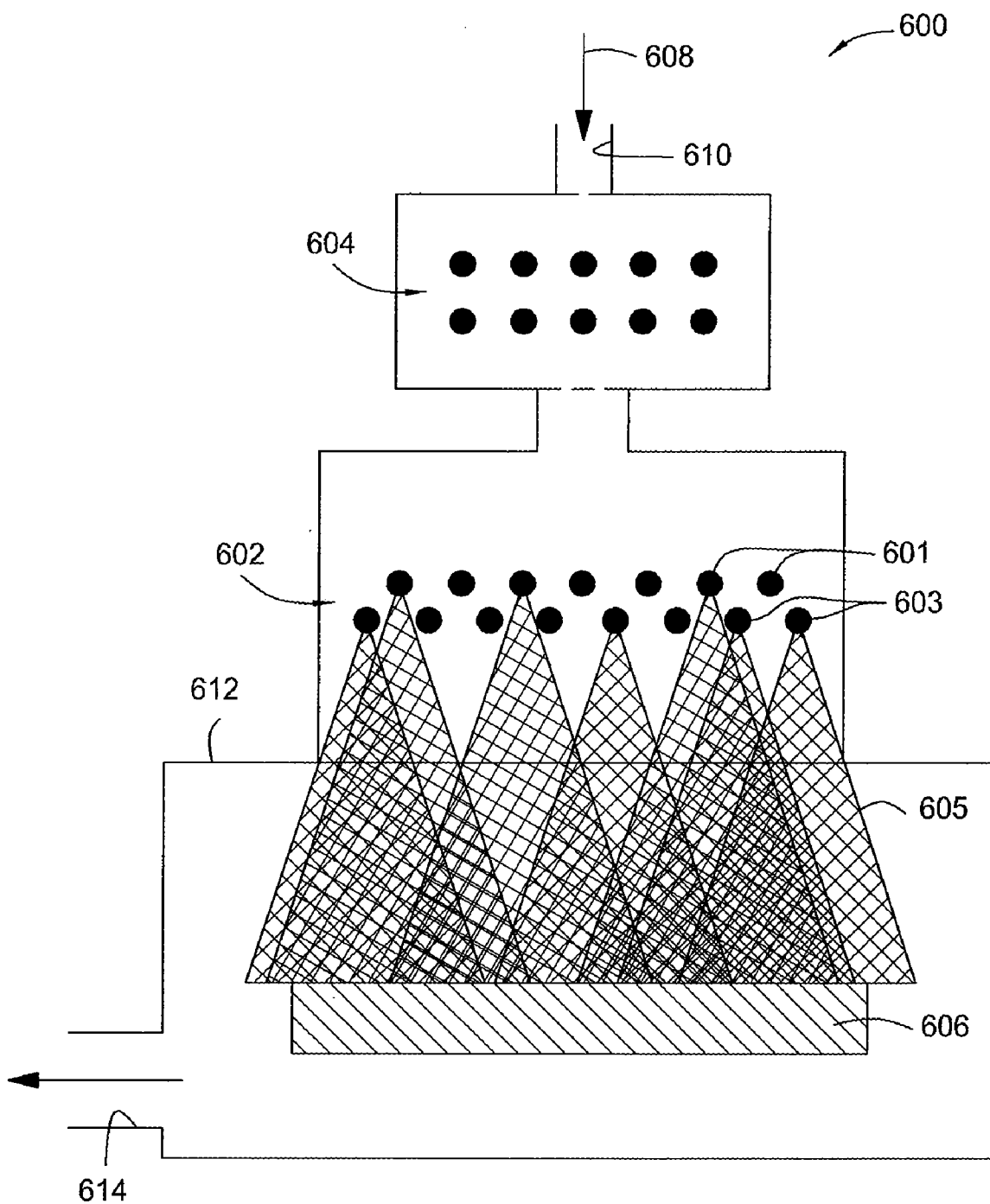

FIG. 6

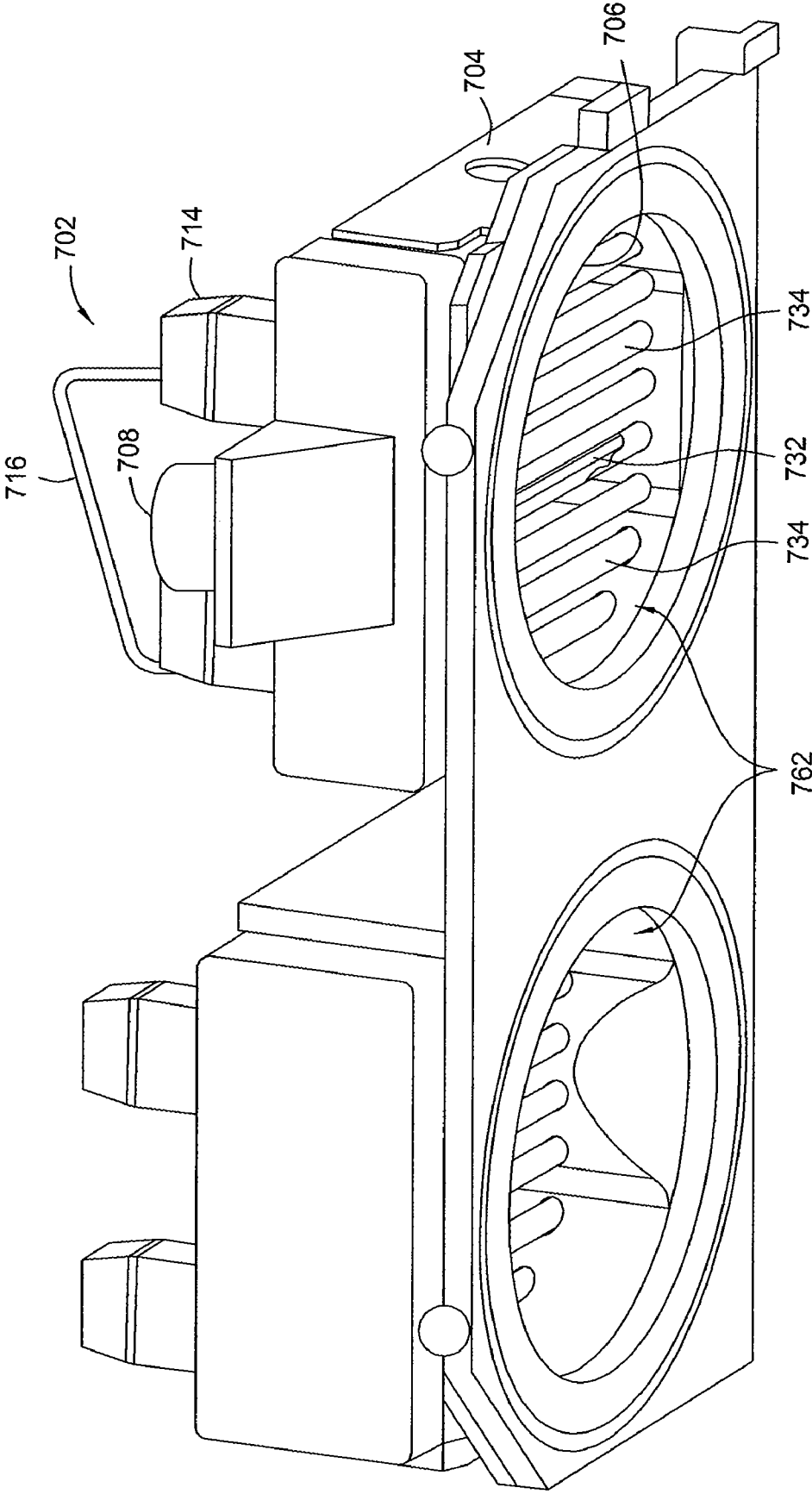

FIG. 7



## HIGH EFFICIENCY UV CURING SYSTEM

### CROSS-REFERENCE TO RELATED APPLICATIONS

[0001] This application is a continuation of co-pending U.S. patent application Ser. No. 11/124,908 (APPM/009433), filed May 9, 2005.

### BACKGROUND OF THE INVENTION

[0002] 1. Field of the Invention

[0003] Embodiments of the invention generally relate to an ultraviolet (UV) cure chamber. More particularly, embodiments of the invention relate to a tandem UV chamber for performing cure processes of dielectric films on substrates and clean processes of surfaces within the tandem chamber.

[0004] 2. Description of the Related Art

[0005] Silicon oxide (SiO), silicon carbide (SiC) and carbon doped silicon oxide (SiOC) find extremely widespread use in the fabrication of semiconductor devices. One approach for forming silicon containing films on a semiconductor substrate is through the process of chemical vapor deposition (CVD) within a chamber. Organosilicon supplying materials are often utilized during CVD of the silicon containing films. As a result of the carbon present in such a silicon supplying material, carbon containing films can be formed on the chamber walls as well as on the substrate.

[0006] Water is often a by-product of the CVD reaction of organosilicon compounds and can be physically absorbed into the films as moisture. Moisture in the air inside the substrate fab provides another source of moisture in un-cured films. The ability of the film to resist water uptake while in queue for subsequent manufacturing processes is important in defining a stable film. The moisture is not part of stable films, and can later cause failure of dielectric material during device operation.

[0007] Accordingly, undesirable chemical bonds and compounds such as water are preferably removed from a deposited carbon containing film. More importantly, thermally unstable organic fragments of sacrificial materials (resulting from porogens used during CVD to increase porosity) need to be removed. It has been suggested to utilize ultraviolet radiation to aid in the post treatment of CVD silicon oxide films. For example, U.S. Pat. Nos. 6,566,278 and 6,614,181, both to Applied Materials, Inc. and incorporated herein in their entirety, describe use of UV light for post treatment of CVD carbon-doped silicon oxide films.

[0008] Therefore, there exists a need in the art for a UV curing chamber which can be used to effectively cure films deposited on substrates. A further need exists for a UV curing chamber that can increase throughput, consume a minimum of energy and be adapted for in situ cleaning processes of surfaces within the chamber itself.

### SUMMARY OF THE INVENTION

[0009] Embodiments of the invention generally relate to an ultraviolet (UV) cure chamber for curing a dielectric material disposed on a substrate. In one embodiment, a tandem process chamber provides two separate and adjacent process regions defined by a body covered with a lid having bulb isolating windows aligned respectively above each process region. The bulb isolating windows are implemented with either one window per side of the tandem process chamber to isolate one or many bulbs from the substrate in one large

common volume, or with each bulb of an array of bulbs enclosed in its own UV transparent envelope which is then in direct contact with the substrate treating environment. One or more UV bulbs per process region are covered by housings coupled to the lid and emit UV light that is directed through the windows onto substrates located within the process regions.

[0010] The UV bulbs can be an array of light emitting diodes or bulbs utilizing any of the state of the art UV illumination sources including but not limited to microwave arcs, radio frequency filament (capacitively coupled plasma) and inductively coupled plasma (ICP) lamps. Additionally, the UV light can be pulsed during a cure process. Various concepts for enhancing uniformity of substrate illumination include use of lamp arrays which can also be used to vary wavelength distribution of incident light, relative motion of the substrate and lamp head including rotation and periodic translation (sweeping), and real-time modification of lamp reflector shape and/or position.

[0011] Residues formed during the curing process are organic/organosilicon and are removed using an oxygen radical and ozone based clean. Production of the necessary oxygen radicals can be done remotely with the oxygen radicals transported to the curing chamber, generated in-situ or accomplished by running these two schemes simultaneously. Since the oxygen radicals generated remotely recombine very rapidly back into molecular oxygen (O<sub>2</sub>), the key to remote oxygen based clean is to generate ozone remotely and to transfer this ozone into the curing chamber where the ozone is then allowed to dissociate into oxygen radicals and oxygen molecules when it comes into contact with heated surfaces inside the curing chamber. Consequently, the ozone is essentially a vehicle for transporting oxygen radicals into the curing chamber. In a secondary benefit of the remote ozone clean, ozone that does not dissociate in the cure chamber can also attack certain organic residues thereby enhancing the oxygen radical clean. Methods of generating the ozone remotely can be accomplished using any existing ozone generation technology including, but not limited to dielectric barrier/corona discharge (e.g., Applied Materials Ozonator) or UV-activated reactors. According to one embodiment, the UV bulbs used for curing the dielectric material and/or additional UV bulb(s) that can be remotely located are used to generate the ozone.

### BRIEF DESCRIPTION OF THE DRAWINGS

[0012] So that the manner in which the above recited features of the present invention can be understood in detail, a more particular description of the invention, briefly summarized above, may be had by reference to embodiments, some of which are illustrated in the appended drawings. It is to be noted, however, that the appended drawings illustrate only typical embodiments of this invention and are therefore not to be considered limiting of its scope, for the invention may admit to other equally effective embodiments.

[0013] FIG. 1 is a plan view of a semiconductor processing system in which embodiments of the invention may be incorporated.

[0014] FIG. 2 is a view of a tandem process chamber of the semiconductor processing system that is configured for UV curing.

[0015] FIG. 3 is a partial section view of the tandem process chamber that has a lid assembly with two UV bulbs disposed respectively above two process regions.

[0016] FIG. 4 is a partial section view of a lid assembly with a UV bulb having a long axis oriented vertically above a process region.

[0017] FIG. 5 is a partial view of a bottom surface of a lid assembly that utilizes an array of UV lamps.

[0018] FIG. 6 is a schematic of a process chamber with a first array of UV lamps selected for curing and a second array of UV lamps selected for activating a cleaning gas.

[0019] FIG. 7 is an isomeric view of a lid assembly for disposal on a tandem process chamber with exemplary arrays of UV lamps arranged to provide UV light to two process regions of the chamber.

#### DETAILED DESCRIPTION

[0020] FIG. 1 shows a plan view of a semiconductor processing system 100 in which embodiments of the invention may be incorporated. The system 100 illustrates one embodiment of a Producer™ processing system, commercially available from Applied Materials, Inc., of Santa Clara, Calif. The processing system 100 is a self-contained system having the necessary processing utilities supported on a mainframe structure 101. The processing system 100 generally includes a front end staging area 102 where substrate cassettes 109 are supported and substrates are loaded into and unloaded from a loadlock chamber 112, a transfer chamber 111 housing a substrate handler 113, a series of tandem process chambers 106 mounted on the transfer chamber 111 and a back end 138 which houses the support utilities needed for operation of the system 100, such as a gas panel 103, and a power distribution panel 105.

[0021] Each of the tandem process chambers 106 includes two processing regions for processing the substrates (see, FIG. 3). The two processing regions share a common supply of gases, common pressure control and common process gas exhaust/pumping system. Modular design of the system enables rapid conversion from any one configuration to any other. The arrangement and combination of chambers may be altered for purposes of performing specific process steps. Any of the tandem process chambers 106 can include a lid according to aspects of the invention as described below that includes one or more ultraviolet (UV) lamps for use in a cure process of a low K material on the substrate and/or in a chamber clean process. In one embodiment, all three of the tandem process chambers 106 have UV lamps and are configured as UV curing chambers to run in parallel for maximum throughput.

[0022] In an alternative embodiment where not all of the tandem process chambers 106 are configured as UV curing chambers, the system 100 can be adapted with one or more of the tandem process chambers having supporting chamber hardware as is known to accommodate various other known processes such as chemical vapor deposition (CVD), physical vapor deposition (PVD), etch, and the like. For example, the system 100 can be configured with one of the tandem process chambers 106 as a CVD chamber for depositing materials, such as a low dielectric constant (K) film, on the substrates. Such a configuration can maximize research and development fabrication utilization and, if desired, eliminate exposure of as-deposited films to atmosphere.

[0023] FIG. 2 illustrates one of the tandem process chambers 106 of the semiconductor processing system 100 that is configured for UV curing. The tandem process chamber 106 includes a body 200 and a lid 202 that can be hinged to the body 200. Coupled to the lid 200 are two housings 204 that are

each coupled to inlets 206 along with outlets 208 for passing cooling air through an interior of the housings 204. The cooling air can be at room temperature or approximately twenty-two degrees Celsius. A central pressurized air source 210 provides a sufficient flow rate of air to the inlets 206 to insure proper operation of any UV lamp bulbs and/or power sources 214 for the bulbs associated with the tandem process chamber 106. The outlets 208 receive exhaust air from the housings 204, which is collected by a common exhaust system 212 that can include a scrubber to remove ozone potentially generated by the UV bulbs depending on bulb selection. Ozone management issues can be avoided by cooling the lamps with oxygen-free cooling gas (e.g., nitrogen or helium).

[0024] FIG. 3 shows a partial section view of the tandem process chamber 106 with the lid 202, the housings 204 and the power sources 214. Each of the housings 204 cover a respective one of two UV lamp bulbs 302 disposed respectively above two process regions 300 defined within the body 200. Each of the process regions 300 includes a heating pedestal 306 for supporting a substrate 308 within the process regions 300. The pedestals 306 can be made from ceramic or metal such as aluminum. Preferably, the pedestals 306 couple to stems 310 that extend through a bottom of the body 200 and are operated by drive systems 312 to move the pedestals 306 in the processing regions 300 toward and away from the UV lamp bulbs 302. The drive systems 312 can also rotate and/or translate the pedestals 306 during curing to further enhance uniformity of substrate illumination. Adjustable positioning of the pedestals 306 enables control of volatile cure by-product and purge and clean gas flow patterns and residence times in addition to potential fine tuning of incident UV irradiance levels on the substrate 308 depending on the nature of the light delivery system design considerations such as focal length.

[0025] In general, embodiments of the invention contemplate any UV source such as mercury microwave arc lamps, pulsed xenon flash lamps or high-efficiency UV light emitting diode arrays. The UV lamp bulbs 302 are sealed plasma bulbs filled with one or more gases such as xenon (Xe) or mercury (Hg) for excitation by the power sources 214. Preferably, the power sources 214 are microwave generators that can include one or more magnetrons (not shown) and one or more transformers (not shown) to energize filaments of the magnetrons. In one embodiment having kilowatt microwave (MW) power sources, each of the housings 204 includes an aperture 215 adjacent the power sources 214 to receive up to about 6000 W of microwave power from the power sources 214 to subsequently generate up to about 100 W of UV light from each of the bulbs 302. In another embodiment, the UV lamp bulbs 302 can include an electrode or filament therein such that the power sources 214 represent circuitry and/or current supplies, such as direct current (DC) or pulsed DC, to the electrode.

[0026] The power sources 214 for some embodiments can include radio frequency (RF) energy sources that are capable of excitation of the gases within the UV lamp bulbs 302. The configuration of the RF excitation in the bulb can be capacitive or inductive. An inductively coupled plasma (ICP) bulb can be used to efficiently increase bulb brilliancy by generation of denser plasma than with the capacitively coupled discharge. In addition, the ICP lamp eliminates degradation in UV output due to electrode degradation resulting in a longer-life bulb for enhanced system productivity. Benefits of the power sources 214 being RF energy sources include an increase in efficiency.

[0027] Preferably, the bulbs 302 emit light across a broad band of wavelengths from 170 nm to 400 nm. The gases selected for use within the bulbs 302 can determine the wavelengths emitted. Since shorter wavelengths tend to generate ozone when oxygen is present, UV light emitted by the bulbs 302 can be tuned to predominantly generate broadband UV light above 200 nm to avoid ozone generation during cure processes.

[0028] UV light emitted from the UV lamp bulbs 302 enters the processing regions 300 by passing through windows 314 disposed in apertures in the lid 202. The windows 314 preferably are made of an OH free synthetic quartz glass and have sufficient thickness to maintain vacuum without cracking. Further, the windows 314 are preferably fused silica that transmits UV light down to approximately 150 nm. Since the lid 202 seals to the body 200 and the windows 314 are sealed to the lid 202, the processing regions 300 provide volumes capable of maintaining pressures from approximately 1 Torr to approximately 650 Torr. Processing or cleaning gases enter the process regions 300 via a respective one of two inlet passages 316. The processing or cleaning gases then exit the process regions 300 via a common outlet port 318. Additionally, the cooling air supplied to the interior of the housings 204 circulates past the bulbs 302, but is isolated from the process regions 300 by the windows 314.

[0029] In one embodiment, each of the housings 204 include an interior parabolic surface defined by a cast quartz lining 304 coated with a dichroic film. The quartz linings 304 reflect UV light emitted from the UV lamp bulbs 302 and are shaped to suit both the cure processes as well as the chamber clean processes based on the pattern of UV light directed by the quartz linings 304 into the process regions 300. For some embodiments, the quartz linings 304 adjust to better suit each process or task by moving and changing the shape of the interior parabolic surface. Additionally, the quartz linings 304 preferably transmit infrared light and reflect ultraviolet light emitted by the bulbs 302 due to the dichroic film. The dichroic film usually constitutes a periodic multilayer film composed of diverse dielectric materials having alternating high and low refractive index. Since the coating is non-metallic, microwave radiation from the power sources 214 that is downwardly incident on the backside of the cast quartz linings 304 does not significantly interact with, or get absorbed by, the modulated layers and is readily transmitted for ionizing the gas in the bulbs 302.

[0030] In another embodiment, rotating or otherwise periodically moving the quartz linings 304 during curing and/or cleaning enhances the uniformity of illumination in the substrate plane. In yet another embodiment, the entire housings 204 rotate or translate periodically over the substrates 308 while the quartz linings 304 are stationary with respect to the bulbs 302. In still another embodiment, rotation or periodic translation of the substrates 308 via the pedestals 306 provides the relative motion between the substrates 308 and the bulbs 302 to enhance illumination and curing uniformity.

[0031] For cure processes for carbon containing films, the pedestals 306 are heated to between 350° C. and 500° C. at 1-10 Torr, preferably 400° C. The pressure within the processing regions 300 is preferably not lower than approximately 0.5 Torr in order to enhance heat transfer to the substrate from the pedestals 306. Substrate throughput increases by performing the cure processes at low pressure in order to accelerate porogen removal as evidenced by the fact that the rate of shrinkage of the deposited films increases as pressure

decreases. Further, the stability of the resulting dielectric constant upon exposure to moisture in the ambient atmosphere of the fab improves when the cure process occurs at a lower pressure. For example, under the same conditions a cure process at 75 Torr created a film with a dielectric constant,  $\kappa$ , of 2.6 while a cure process at 3.5 Torr created a film with a  $\kappa$  of 2.41. After completion of a standard accelerated stability test, the dielectric constant of the film cured at 75 Torr increased to 2.73 while the  $\kappa$  of the film cured at 3.5 Torr increased approximately half as much to 2.47. Thus, the lower pressure cure produced a lower dielectric constant film with approximately half the sensitivity to ambient humidity.

#### Example 1

[0032] A cure process for a carbon doped silicon oxide film includes introduction of fourteen standard liters per minute (slm) of helium (He) at eight Torr for the tandem chamber 106 (7 slm per side of the twin) via each inlet passage 316. For some embodiments, the cure processes use nitrogen (N<sub>2</sub>) or argon (Ar) instead or as mixtures with He since primary concern is absence of oxygen unless other components are desired for reactive UV surface treatments. The purge gas essentially performs two main functions of removing curing byproducts and promoting uniform heat transfer across the substrate. These non-reactive purge gases minimize residue build up on the surfaces within the processing regions 300.

[0033] Additionally, hydrogen can be added to beneficially remove some methyl groups from films on the substrates 300 and also scavenge oxygen which is released during curing and tends to remove too many methyl groups. The hydrogen can getter residual oxygen remaining in the chamber after the oxygen/ozone based clean and also oxygen out-gassed from the film during the cure. Either one of these sources of oxygen can potentially damage the curing film by photo-induced reactions of oxygen radicals formed by the short wavelength UV potentially used in the cure and/or by binding with methyl radicals to form volatile byproducts that can leave the final film poor in methyl, yielding poor dielectric constant stability and/or excessively high film stress. Care must be exercised in the amount of hydrogen introduced into the cure process since with a UV radiation wavelength less than approximately 275 nm the hydrogen can form hydrogen radicals that can attack carbon-carbon bonds in the film and also remove methyl groups in the form of CH<sub>4</sub>.

[0034] Some cure processes according to aspects of the invention utilize a pulsed UV unit which can use pulsed xenon flash lamps as the bulbs 302. While the substrates 308 are under vacuum within the processing regions 300 from approximately 10 milli Torr to approximately 700 Torr, the substrates 308 are exposed to pulses of UV light from the bulbs 302. The pulsed UV unit can tune an output frequency of the UV light for various applications.

[0035] For clean processes, the temperature of the pedestals 306 can be raised to between about 100° C. and about 600° C., preferably about 400° C. With the UV pressure in the processing regions 300 elevated by the introduction of the cleaning gas into the region through the inlet passages 316, this higher pressure facilitates heat transfer and enhances the cleaning operation. Additionally, ozone generated remotely using methods such as dielectric barrier/corona discharge or UV activation can be introduced into the processing regions 300. The ozone dissociates into O<sup>-</sup> and O<sub>2</sub> upon contact with the pedestals 306 that are heated. In the clean process, elemental oxygen reacts with hydrocarbons and carbon spe-

cies that are present on the surfaces of the processing regions **300** to form carbon monoxide and carbon dioxide that can be pumped out or exhausted through the outlet port **318**. Heating the pedestals **306** while controlling the pedestal spacing, clean gas flow rate, and pressure enhances the reaction rate between elemental oxygen and the contaminants. The resultant volatile reactants and contaminants are pumped out of the processing regions **300** to complete the clean process.

[0036] A cleaning gas such as oxygen can be exposed to UV radiation at selected wavelengths to generate ozone in-situ. The power sources **214** can be turned on to cause UV light emission from the bulbs **302** in the desired wavelengths, preferably about 184.9 nm and about 253.7 nm when the cleaning gas is oxygen, directly onto the surfaces to be cleaned and indirectly by focusing with the quartz linings **304**. For example, UV radiation wavelengths of 184.9 nm and 253.7 nm optimizes cleaning using oxygen as the cleaning gas because oxygen absorbs the 184.9 nm wavelength and generates ozone and elemental oxygen, and the 253.7 nm wavelength is absorbed by the ozone, which devolves into both oxygen gas as well as elemental oxygen.

#### Example 2

[0037] For one embodiment, a clean process includes introduction of 5 slm of ozone and oxygen (13 wt % ozone in oxygen) into the tandem chamber, split evenly within each processing region **300** to generate sufficient oxygen radicals to clean deposits from surfaces within the processing regions **300**. The O<sub>3</sub> molecules can also attack various organic residues. The remaining O<sub>2</sub> molecules do not remove the hydrocarbon deposits on the surfaces within the processing regions **300**. A sufficient cleaning can occur with a twenty minute clean process at 8 Torr after curing six pairs of substrates.

[0038] FIG. 4 illustrates a partial section view of a lid assembly **402** with a UV bulb having a long axis **403** oriented vertically above a process region **400**. The shape of the reflector in this embodiment is different than in any of the other embodiments. In other words, the reflector geometry must be optimized to ensure maximum intensity and uniformity of illumination of the substrate plane for each lamp shape, orientation and combination of single or multiple lamps. Only one half of a tandem process chamber **406** is shown. Other than the orientation of the bulb **403**, the tandem process chamber **406** shown in FIG. 4 is similar to the tandem process chamber **106** shown in FIGS. 2 and 3. Accordingly, the tandem process chamber **406** can incorporate any of the aspects discussed above.

[0039] FIG. 5 shows a partial view of a bottom surface **500** of a lid assembly that utilizes an array of UV lamps **502**. The array of UV lamps **502** can be disposed within a housing above a tandem process chamber instead of single bulbs as depicted in the embodiments shown in FIGS. 2-4. While many individual bulbs are depicted, the array of UV lamps **502** can include as few as two bulbs powered by a single power source or separate power sources. For example, the array of UV lamps **502** in one embodiment includes a first bulb for emitting a first wavelength distribution and a second bulb for emitting a second wavelength distribution. The curing process can thus be controlled by defining various sequences of illumination with the various lamps within a given curing chamber in addition to adjustments in gas flows, composition, pressure and substrate temperature. In addition on a multi-curing chamber system, the curing process can be further refined by defining sequences of treatments in each of

the tandem curing chambers each of which is controlled independently with respect to parameters such as lamp spectrum, substrate temperature, ambient gas composition and pressure for the specific portion of the cure for which each is used.

[0040] The array of UV lamps **502** can be designed to meet specific UV spectral distribution requirements to perform the cure process and the clean process by selecting and arranging one, two or more different types of individual bulbs within the array of UV lamps **502**. For example, bulbs may be selected from low pressure Hg, medium pressure Hg and high pressure Hg. UV light from bulbs with a wavelength distribution particularly suited for cleaning can be directed to the entire process region while UV light from bulbs with a wavelength distribution particularly suited for curing can be directed specifically to the substrate. Additionally, bulbs within the array of UV lamps **502** directed specifically at the substrate may be selectively powered independently from other bulbs within the array of UV lamps **502** such that select bulbs are turned on for either the clean process or the cure process.

[0041] The array of UV lamps **502** can utilize highly efficient bulbs such as UV light emitting diodes. UV sources powered by microwave or pulsed sources have a conversion efficiency of five percent compared to low power bulbs, such as 10 W-100 W, that can be in the array of UV lamps **502** to provide a conversion efficiency of about twenty percent. With the microwave power source ninety five percent of the total energy is converted to heat that wastes energy and necessitates extra cooling requirements while only five percent of the energy is converted to UV emission. The low cooling requirement of the low power bulbs can allow the array of UV lamps **502** to be placed closer to the substrate (e.g., between one and six inches) to reduce reflected UV light and loss of energy.

[0042] Furthermore, the bottom surface **500** of the lid assembly can include a plurality of gas outlets **504** interleaved within the array of UV lamps **502**. Accordingly, curing and cleaning gases can be introduced into a process region within a chamber from above (see, FIGS. 6 and 7).

[0043] FIG. 6 schematically illustrates a process chamber **600** with a first array of UV lamps **602** selected for curing and a second array of UV lamps **604** remotely located and selected for activating a cleaning gas. The first array of UV lamps **602** is divided into a first group of bulbs **601** having a first wavelength distribution and a second group of bulbs **603** having a second wavelength distribution. Both groups of bulbs **601**, **603** within the first array of UV lamps **602** focus UV light (depicted by pattern **605**) onto a substrate **606** during a cure process. Thereafter, the cleaning gas (depicted by arrows **608**) is introduced through inlet **610** and subjected to UV radiation from the second array of UV lamps **604** to preferably generate ozone. Subsequently, ozone enters a process region **612** where oxygen free radicals caused by activation of the ozone clean the processing region **612** prior to being exhausted via outlet **614**.

[0044] FIG. 7 shows an isomeric view of a lid assembly **702** for disposal on a tandem process chamber (not shown) with exemplary arrays of individually isolated UV lamps **762** arranged to provide UV light to two process regions of the chamber. Similar to the embodiment shown in FIGS. 2 and 3, the lid assembly **702** includes a housing **704** coupled to an inlet (not visible) along with a corresponding outlet **208** oppositely located on the housing **704** for passing cooling air across UV lamp bulbs **732** covered by the housing **704**. In this embodiment with the arrays of individually isolated UV lamps **762**, the cooling air is directed into and passes through

an annulus defined between each bulb 732 and a window or UV transmitting protective tube surrounding each bulb 732 individually. An interior roof 706 of the housing 704 can provide a reflector for directing the UV light to a substrate and a blocker to facilitate diffusion of gases supplied into a top of the housing by gas inlet 716.

[0045] Any of the embodiments described herein can be combined or modified to incorporate aspects of the other embodiments. While the foregoing is directed to embodiments of the present invention, other and further embodiments of the invention may be devised without departing from the basic scope thereof, and the scope thereof is determined by the claims that follow.

What is claimed is:

1. An ultraviolet (UV) curing chamber for curing dielectric materials disposed on substrates, comprising:

a body defining first and second process regions that are separate and adjacent to one another;

a lid coupled to a top of the body to cover the first and second process regions, wherein the lid includes first and second quartz windows aligned respectively above the first and second process regions;

first and second UV sources disposed respectively above the first and second windows;

first and second housings coupled to the lid and respectively covering the first and second UV sources; and first and second reflectors disposed respectively in the first and second housings and each of the first and second reflectors are movable to adjust patterns of UV light directed by the reflectors into the process regions.

2. The UV curing chamber of claim 1, wherein gas inlets into the first and second process regions are adapted to supply ozone to the process regions for a cleaning process.

3. The UV curing chamber of claim 1, further comprising a central air source in fluid communication with an interior of the first housing and an interior of the second housing to cool the first and second UV sources disposed therein.

4. The UV curing chamber of claim 3, further comprising a common exhaust system in fluid communication with the interior of the first housing and the interior of the second housing to collect heated air therein and remove ozone from the air.

5. The UV curing chamber of claim 1, further comprising first and second heated and movable pedestals disposed respectively within the first and second process regions for supporting the substrates.

6. The UV curing chamber of claim 1, further comprising at least one power source for activation of the first and second UV sources and each of the at least one power source being at least one microwave generator.

7. The UV curing chamber of claim 1, further comprising at least one power source for activation of the first and second UV sources, each power source being at least one radio frequency generator.

8. The UV curing chamber of claim 1, wherein each of the first and second UV sources comprise one or more UV bulbs.

9. The UV curing chamber of claim 8, wherein each of the one or more UV bulbs have long axes oriented vertically with respect to first and second substrates located respectively in the first and second process regions.

10. The UV curing chamber of claim 8, wherein the UV curing chamber is mounted on a transfer chamber.

11. The UV curing chamber of claim 1, wherein the first and second housings have respective first and second quartz linings coated with dichroic films.

12. The UV curing chamber of claim 8, wherein of the first and second UV sources each comprise a first UV bulb and a second UV bulb.

13. The UV curing chamber of claim 12, wherein the first UV bulb emits UV light of a first wavelength distribution different from a second wavelength distribution emitted by the second UV bulb.

14. The UV curing chamber of claim 12, wherein the first UV bulb is capable of being turned on independently of the second UV bulb.

15. An ultraviolet (UV) curing chamber for curing dielectric materials disposed on substrates, comprising:

a body defining first and second process regions that are separate and adjacent to one another;

a lid coupled to a top of the body to cover the first and second process regions, wherein the lid includes first and second quartz windows aligned respectively above the first and second process regions;

first and second UV sources disposed respectively above the first and second windows; and

first and second housings coupled to the lid and respectively covering the first and second UV sources and the first and second housings have respective first and second quartz linings coated with dichroic films.

16. The UV curing chamber of claim 15, wherein the dichroic film comprises a periodic multilayer film composed of non-metallic dielectric materials having alternating high and low refractive index.

17. The UV curing chamber of claim 15, further comprising first and second heated and movable pedestals disposed respectively within the first and second process regions for supporting the substrates.

18. The UV curing chamber of claim 15, further comprising at least one power source for activation of the first and second UV sources, each power source being at least one microwave generator or at least one radio frequency generator.

19. The UV curing chamber of claim 15, wherein the first and second UV sources comprise one or more UV bulbs having long axes oriented vertically with respect to first and second substrates located respectively in the first and second process regions.

20. The UV curing chamber of claim 15, wherein the UV curing chamber is mounted on a transfer chamber.

\* \* \* \* \*