

10



Europäisches Patentamt
European Patent Office
Office européen des brevets

11 Publication number:

**0 084 685
B1**

12

EUROPEAN PATENT SPECIFICATION

43 Date of publication of patent specification: **10.07.85**

51 Int. Cl.⁴: **G 08 B 25/00, G 08 B 27/00**

21 Application number: **82200087.3**

22 Date of filing: **26.01.82**

54 **Alarm control center.**

43 Date of publication of application:
03.08.83 Bulletin 83/31

45 Publication of the grant of the patent:
10.07.85 Bulletin 85/28

84 Designated Contracting States:
DE FR GB IT NL SE

58 References cited:
**EP-A-0 021 232
DE-A-3 023 598
US-A-3 925 763
US-A-4 095 220**

**ERICSSON REVIEW, vol. 56, no. 4, 1979,
Stockholm, C. HAGLAND et al. "ALARMCOM-a
Computer-Controlled Alarm Communication
System", pages 142 to 150
WIRELESS WORLD, vol. 84, no. 1515, 1978,
Haywards Heath, R.J. CHANCE "Multiplexed
Alarm", pages 73,74**

73 Proprietor: **N.V. Philips' Gloeilampenfabrieken
Groenewoudseweg 1
NL-5621 BA Eindhoven (NL)**

72 Inventor: **Ulicki, Edward M.
c/o INT. OCTROOIBUREAU B.V. Prof. Holstlaan 6
NL-5656 AA Eindhoven (NL)**
Inventor: **Schlisser, Gabor
c/o INT. OCTROOIBUREAU B.V. Prof. Holstlaan 6
NL-5656 AA Eindhoven (NL)**

74 Representative: **Strijland, Wilfred et al
INTERNATIONAAL OCTROOIBUREAU B.V. Prof.
Holstlaan 6
NL-5656 AA Eindhoven (NL)**

EP 0 084 685 B1

Note: Within nine months from the publication of the mention of the grant of the European patent, any person may give notice to the European Patent Office of opposition to the European patent granted. Notice of opposition shall be filed in a written reasoned statement. It shall not be deemed to have been filed until the opposition fee has been paid. (Art. 99(1) European patent convention).

Description

Background of the invention

The invention relates to centralized monitor and control systems for monitoring the condition of alarm sensors and for controlling different alarm outputs depending on the alarm sensor condition. Although several sensor configurations are feasible the only type mentioned for reasons of convenience will be the sensor loop. Specifically, the invention relates to an alarm control center as recited in the preamble of Claim 1.

In prior art multiple sensor loop systems, the sensor loop and alarm outputs had to be connected to the central system in a specific order of connection for proper operation of the system. For an initial installation, these systems performed adequately. However, with many industrial buildings, the security requirement and usage of various rooms and areas will change thereby requiring the adding, deleting and reassigning of several sensor loops. With the prior art systems, these changes may be very extensive and tedious to implement while also prone to numerous errors.

Specifically, a paper by C. Hagland, et al, Alarmcon—a computer-controlled alarm communication system, Ericsson review, Vol. 56, No. 4, 1979, p. 142—150 describes a relevant prior art system. Notably, this reference describes the provision of several security levels according to a daily or otherwise predetermined cycle. It has been found that these transitions between these different security levels must be controlled sensibly: a "real alarm" condition at a high security level instant may not be obscured by a transition to a lower security level. Alternatively a "critical" situation at a low security level instant should not trigger a "real alarm" condition simply because a short delay was incurred for example, because a temporarily high workload took somewhat more time than expected. It is an object of the invention to control transitions between respective security levels while minimizing the risk for obscuring real alarm situations and/or rash generation of such situations. The object of the invention is realized by the characterizing features of claim 1. Further advantageous features are recited in the dependent claims.

The physical facility associated with a sensor loop may be a door or window. In that case "closed" would be the standard condition, while "open" would be a hazardous condition. Of course in certain circumstances, the hazardous condition would be allowable. The physical facility may also be the air condition in a room. A certain temperature range and/or a certain clearness of the air would represent the standard condition. Alternatively, a higher temperature range or a diminished clearness of the air would be caused by fire and/or smoke and thus represent a hazardous condition. Alarm output elements could be represented by high-power sirens, local audio buzzers, self-acting telephone dialers or displays (single lamps, seven segment

LED's or the like, or even video displays). Preferably, the control center comprises switching means for periodically turning off and on selected circuits during power outages.

The input sensor array provides signals to an analog input system located in the alarm control center. The purpose of the analog input system is to provide necessary signal conditioning of the signals received from the external environment. The analog input system also provides protecting circuitry so that the alarm control center may be safe from sabotage.

The processor portion of the alarm control center is a microprocessor-organized special purpose computer which receives the sensor signals after analog to digital conversion. The latter is the primary signal measured by the processor.

If there are deviations from prescribed limits, the processor functions to provide alarms via the alarm output system and also to communicate conditional changes to a higher level station (such as a central console or processor station) via its controller for external communications).

The processor also has local control and display. Control is via a keyboard. This keyboard may be energized by an operator, or an installer, provided he has the proper coded key to use the system. When a user is present, and has the proper key inserted, the display on the alarm control center is activated and provides detailed information regarding system operation.

The alarm output system is a combined software and hardware configuration, which is programmable to allow a variety of different alarm schemes to be implemented under user control. The alarm output system is connected to an external alarm array which may include sirens, autodialers, local audio buzzers and display.

In addition to local control of the alarm control center, there is also a remote bus built into this system. The remote bus input/output system is capable of handling up to 16 peripherals, which may include a remote control unit, a card reader and keyboard, door control units, printers, etc.

The alarm control center has an external-communications controller. The external communications-controller is designed to provide an interface through the PTT network to a higher level system. In most cases the higher level system is an alarm central station.

Brief description of the drawings

With the above and additional objects and advantages in mind as will hereinafter appear, the invention will be described with reference to the accompanying drawings in which:

Fig. 1 is a block diagram of the main components of the alarm control center;

Fig. 2 shows a schematic of a typical sensor loop;

Fig. 3 is a block diagram of the alarm control center;

Fig. 4 shows a block diagram of a typical remote control unit;

Fig. 5 shows in block diagram form the external communications board;

Fig. 6 shows in block diagram form the power supply board of the invention;

Fig. 7 provides in block diagram form, the organization of the software used to control the alarm control center; and

Fig. 8 provides in block diagram form the organization of the software used to control a typical remote control unit.

Description of the preferred embodiment

In Fig. 1 there is shown in block diagram form the major components of the alarm control center. For simplicity, the respective interconnections between the subsystems and functional blocks have not been shown. These components include an input/output board 100, a processor board 200, an external communications board 300 and a power supply board 400, each provided with printed wiring and mounted discrete and integrated circuit modules.

The I/O board 100 represents the interfacing of the processor to the external world. The analog inputs and signal alarm outputs are mounted on this board. The analog inputs originate from external sensor loops which inputs are multiplexed under microprocessor control, the multiplex output signal being provided to the processor board 200 for further processing. The relevant subsystems 110, 120, 130 will be described hereinafter. The processor board 200 contains among other elements the processor itself (205), associated memory (210/215), control inputs via keyboard and operator/tamper switches (220), a digital display and indicator lights (225) and an analog-to-digital converter (230).

The external communications board 300 provides interface to a telephone system. Contained on this board is an interface transformer with wire protection and the necessary hardware to automatically dial, through the telephone exchange, to a central alarm station. After the central station has been dialed, the communications board 300 contains the hardware to sense the connection and a modem to facilitate two-way data transmission. This communications board 300 also includes necessary circuitry for secure data transmission including block check character generation and detection means and encryption and decryption means.

The power supply board 400 provides an interface to the line voltage and a battery pack. The output of the power supply board 400 provides the necessary voltages and currents for operating the micro-processor system, the input sensor array, the alarm output, as well as some peripheral devices (not shown). Means are contained on the power supply board 400 for detecting the loss of line voltage, failure of the battery pack, or failure of the power supply itself.

The input/output board

The Input/Output board 100 is capable of receiv-

ing the analog signals from thirty-two separate sensor loops. Fig. 2 shows a typical sensor loop and the relevant circuitry on the input/output board 100. The sensor is indicated by reference number 102 and may comprise up to ten individual 560-ohm sensors connected in a series loop. 12 volt DC power is applied to one end of each sensor loop 102 from the power supply board 400 through respective resistors R1, which typically are 5.6 K-ohms, the other end of the each sensor loop 102 being connected to ground. With this configuration, assuming a balanced loop, 6 volts DC will appear at the junction of resistor R1 and the sensor loop 102, when the sensor loop resistance is 5.6 kohms.

In certain situations fire detection sensors are used. These sensors are characteristically low impedance devices. Thus, for retaining flexibility, a resistor R2 of 680 ohms is provided in parallel with resistor R1 to lower the overall effective resistance. Depending then on which loop the fire detection devices are situated, a jumper may be inserted across the terminals 104 thereby connecting R2 in parallel with R1. The input/output board 100 also has a resistor R3 connected to the junction of R1 and the sensor loop 102, which resistor R3 provides the analog signal from the sensor loop 102.

In order to protect the system from sabotage, each input sensor signal includes a line protection circuit 110 which comprises a diode 112 in parallel with a capacitor 114 which coupled the loop signal from resistor R3 to ground. The diode 112 is selected to conduct at 15 volts. So arranged, the line protection circuit 110 provides protection from high voltage as well as RF signals being induced on the sensor leads.

The input loop signal is then passed to a 32-to-1 multiplexer 120, which is controlled via signals on a bus 122 from the processor board 200. In a typical arrangement, the multiplexer 120 may comprise four 8-to-1 multiplexers having the inputs coupled to the respective 32 sensor loops while the outputs therefrom are coupled to a 4-to-1 multiplexer. This configuration would allow for the exclusive scanning of predetermined groups of sensor inputs as well as the scanning of all the sensor inputs. For simplicity only one input contact has been shown.

The output of the multiplexer 120 is then connected to a signal conditioner 130 which comprises an inverting amplifier 132 which also provides a level shift so that the input signal, which nominally is at 6 volts DC, is scaled down to 2 volts (inverted) for use on the processor board 200. This is accomplished by applying the output of the multiplexer 120 to the inverting input of the amplifier 132 while applying 4 volts DC, taken from a voltage divider 134, to the non-inverting input thereof.

The input/output board 100 also contains eight alarm relays 140 which are shown schematically in Fig. 3. These may be arranged as normally opened, while they can be selectively closed by the installer. Those relays may be energized

individually under the control of the processor and may be used to activate, for example alarms, lights, horns, sirens, or any other desired output.

The processor board

The processor board 200 is the basic control board in the alarm control center. This board 200 is shown in Fig. 3 and includes a microprocessor 205, ROM memory 210, RAM memory 215, an input keyboard 220, a four digit LED display 225 and an analog-to-digital converter 230. A suitable microprocessor which may be used in this system is the Intel 8039 which includes 128 words of internal RAM not shown separately. The primary interconnecting data path is formed by bus 207, data and address/control lines not being shown separately. The external ROM memory 210 contains the system program. Also accesses by the 8-bit bus is the external RAM memory 215 which has a total of 1024×8 bits of memory. Since this is a volatile memory, a battery shown hereinafter is provided therefor in the event of the loss of line voltage by way of battery back-up power system. A latch 235 is included for address latching by both the ROM 210 and RAM 215.

The analog input signals are passed through the A/D converter 230 which converts this signal to an 8-bit digital code which is transmitted to the microprocessor 205 by the 8-bit I/O bus.

In parallel with the keyboard 220, the microprocessor 205 receives input digital data of various switch inputs 240 through a 16-bit I/O bus expander 250. The switch inputs include:

1. operator switch
2. calibration switch
3. tamper switch
4. installer switch
5. walk test switch
6. initialization switch
7. line voltage
8. battery
9. power supply.

A second 16-bit I/O bus expander 260 is used to provide the systems outputs. Signals from the microprocessor 205 carried over the 8-bit bus cause the bus expander 260 to activate the appropriate alarm relay in a plurality of relays 140.

Elements 102/110, 120, 130 have been shown in the previous figure. The control by way of line 122 may be effected by appropriate signals on bus 207.

The alarm control center has provisions for being remotely operated. When the protected premises are being secured for the night, for example, means are provided whereby the system may be activated at or near the exit door. To this end, peripheral devices 270 are coupled to the microprocessor 205 via a two-wire two-way bus 268.

There are nine different types of peripheral devices 270 which can be used with the alarm control center. These include a basic remote

control unit (BRCU), display RCU (DRCU), DRCU with electric strike lock (ESL), security enable RCU (SRCU), SRCU with ESL, logging printer unit (LPU), interface control unit (ICU), door control unit (DCU) and security enable alarm control center.

The peripheral devices 270, while having different configurations, are, in general, set up similarly as shown in Fig. 4. The remote bus data-in signal is passed through filter 271, buffer 272 and then to a microprocessor 273, which may be the same as microprocessor 205. Other inputs to the microprocessor 273 are from switched inputs 274 which may include a door sensor, a key switch and a tamper switch. In addition, communication with further peripherals 270A may be had along the same bus. Through a bus expander 275 the microprocessor 273 may interact with a card reader 276 and a keyboard 277, and may also activate a door relay 278. A carrier loss detection circuit 279 is also included and controls power to the peripheral device. This circuit 279, which may include a resistor/capacitor charging circuit not shown coupled to a threshold detector arranged to trigger if the voltage across the charging circuit is not discharged by the remote bus input, is coupled to the output of the filter 271 and has an output coupled to the microprocessor. Often, a separate display element 279A could be useful, for example one or two LED's.

External communications board

The external communications board 300 provides the interface of the alarm control center to the transmission system. This board performs the following functions:

1. Accept messages for transmission from the alarm control center to a higher level device;
2. Provide pulse or touch-tone dial capability for switched network applications;
3. Offer encryption/decryption facilities for messages requiring the same;
4. Compute block character check sums for each message transmitted;
5. Provide modem serial data transmission capacity;
6. Provide receiver tone and ring detection;
7. Provide voice transmission capability for eavesdropping;
8. Receive messages and provide error checking capabilities;
9. Automatic retransmission of messages having communication errors; and
10. Pass valid messages to the alarm control center.

Fig. 5 is a functional block diagram of the modules in the communication board 300, all of which are either commercially available items or have obvious constructions.

A microprocessor 305 is coupled to the bus 207 from the processor board 200. The microprocessor 305 may be Intel type number 8741. The microprocessor 305 has a first bus 310 coupled to a dual bus expander 315 (Intel 8243).

The output from the bus expander 315 is coupled, along with a second bus 320 from the microprocessor 305, to a Usart 325 type 8251A, an encryption/decryption module 330 type 8294, a pulse dialer 335 type 14409 and a tone dialer 340 type 14410 (both makes Motorola). The input to and output from the Usart 325 may be applied selectively to a V24 interface 345 to dedicated lines 3450 or to a modem 350 of type 14412. The selection is effected by switch 3250 that is microprocessor controlled. Block 324 symbolizes the provision of necessary synchronizing signals. The output from modem 350 is applied to telephone lines indicated by A, B, such as may be self-dialed. The interconnection is effected through a relay 355 that is controlled by the microprocessor 305, and by a switching circuit 360, controlled by the pulse dialer 335. Return data communicated via telephone lines A, B is processed through the switching circuit 360 and a filter amplifier 365 before being forwarded to modem 350 and Usart 325.

The relay 355 also selectively couples the switching circuit 360 with a voice alarm detector 370, having an eavesdropping microphone 375 coupled thereto, and to the tone dialer 340. To access the telephone lines A, B, the communications board 300 also includes a receiver tone detection circuit 380 and a ring detection circuit 384 both coupled to the microprocessor 305 through a switch 388 controlled via the bus expander 315.

Since some of the modules used on the external communications board 300 require -12 volts DC, a secondary power supply 390 is included thereon and is energized by the main power supply 400.

In another embodiment of the invention, the microprocessor 305 may be a type number Intel 8035 and communicates with the microprocessor 205 via the peripheral devices 270 remote bus.

Power supply board

Fig. 6 shows a block diagram of the power supply board 400. The power supply board 400 includes a transformer 410 which steps down the mains voltage on input line 409 to 18 volts AC. The transformer 410 includes several input taps so that it is adaptable to several line voltages. The 18 volt AC output from the transformer 410 is applied to a pair of diode bridges 420 for rectification. A stabilized 12 volt DC supply 430 is coupled to the output of the diode bridges 420 and provides the stabilized 12 volt DC used throughout the alarm control systems. A 5 volt DC regulator 440 is coupled to the 12 volt DC output to provide an output of 5 volts DC also used in the system. A stabilization sensing circuit 450 is included in the power supply board 400 which provides an output signal on line 451 to the microprocessor 205 when there is a failure in the stabilized 12 volt DC supply 430. In case of such failure a single or multiple line 452 is provided for either controlling a back-up facility, or for receiving emergency power therefrom, or both.

In the event of failure of the input line voltage, the power supply board 400 includes a battery pack 460 as a back-up power source. Coupled to the battery pack 460 is a sensing and switching circuit 470 which checks the condition of the battery pack 460 and provides an output signal on line 471 upon failure of the battery pack 460. A battery charging circuit 480 is coupled to the output of the diode bridges 420 and maintains the battery pack 460 at full charge.

When there is a loss of stabilization, the stabilization sensing circuit 450, in addition to its signalling output, disconnects the 12 volt DC supply from the output, disconnects the charging circuit 480 from the battery pack 460, and couples the battery pack 460 to the 12 volt DC output.

Notwithstanding the above, if the battery pack 460 output voltage falls below a certain level, the sensing circuit 470, in addition to its signal to the microprocessor 205, disconnects the battery pack 460 to prevent damage thereto due to extreme discharge. In certain cases an additional power output line 481 could provide emergency power to selected emergency signalling means.

These is also included on the power supply board 400, a line voltage sensing circuit 490 coupled to the output of the diode bridges 420 which signals the microprocessor 205 on line 491 upon failure of the line voltage.

Software

Fig. 7 provides a block diagram the organization of the software used to control the alarm control center. Each block represents a respective routine or software module. Solid lines represent changeovers between program modules within the operating condition. Dotted lines represent transitions that occur only once or only by way of synchronization. The Exec module 500 provides the communication and control of the entire software system. The system is first established as regards the mode of operation, assignment of critical parameter values and of the respective sensor loops via an initialization routine 510. This routine is hardware programmable so that when there is a loss of power followed by a power restoration or when a reset switch has been pressed, the system will go to the selected program initialization.

Following initialization, the Exec calls the various other routines as required, which will now be described.

A loop scanning routine 520 sequentially interrogates all the input sensor loops and decides whether an acceptable or a non-acceptable tolerance exists with respect to an initial reference value that is based on the type of sensor loop being examined. At initialization, the loop scanning routine 520 determines the existing voltage at the relevant sensor loop and if it is within an acceptable tolerance it takes this initial value as the reference voltage for that loop for all later determinations of sensor loop conditions.

If upon interrogation of a sensor loop a change in status, i.e. a deviation from the stored reference

value that is larger than a predetermined tolerance variation, is detected, the program presets a change counter to zero and furthermore stores the new condition. When in subsequent scans there is no change in status, i.e. no further excessive deviation from the stored "new" condition, the counter upon each successive scan is advanced by one and the counter position is compared with a maximum. Since the scanning of a particular loop is repeated approximately every 30 milliseconds, the counter is allowed to go to 5, representing 150 ms during which the input has been in the new condition. The loop scanner routine 520 then enters into a high speed mode dedicating its scanning to the particular loop only for 32 cycles. If during this period at least 70% of the time the input parameter value is in the new condition, then this status is processed as a valid input change. If no previous alarm exists for the loop, preparations are made to call the alarm processor routine 540.

The switch scanner routine 530 monitors the operation of the front panel keyboard, the installer and operator key switches, the alarm control center door tamper switch, the installer initialization and walk test switches, as well as the status of the line voltage, battery and power supply.

The switch scanner routine 530 will call the alarm processor routine 540 under the following conditions:

1. tamper switch detected when both the operator and installer switches are not set;
2. loss of line voltage;
3. failure of stand-by battery- and
4. failure of the power supply only, if the line voltage is present.

If in the case of failure of the stand-by battery there is also failure of either the line voltage or the power supply, the switch scanner routine 530 puts the alarm control center program into a "wait" state, stopping all further scanning and processing and returning to the Exec routine 500. The system may only be taken out of this "wait" condition by a hardware reset by the installer.

The alarm processing routine 540 receives the alarm calls triggered by failures in the input sensor loops, peripherals, tamper switches and hardware. For each alarm call, there are four possible modes of operation, namely night mode, guarded and unguarded, and day mode, guarded and unguarded. The alarm processing routine 540 first determines the particular mode of operation and then retrieves a preprogrammed table of alarm indications for the particular alarm call and mode of operation. The alarm indications are as follows:

1. ACC(ess) buzzer on
2. External alarm on
3. Power failure LED on
4. ACC alarm on
5. Deterrent siren and outdoor light on
6. I/O linkage
7. External autodial on
8. Spare

The alarm processing routine 540 then sets the bits for each specific output and then calls the alarm output generation routine 555.

The alarm output generation routine 555 performs the task of actuating (or deactuating) the various alarm relays based upon multi-bit words set by the alarm processing routine 540.

The scrolling routine 560 provides for the programming of the alarm control center by controlling the digital data being displayed, for example, linewise on a cathode ray tube and by storing on an appropriate position on the display the new information entered by an operator or an installer. In similar way the display could be effected as a plurality of digits on 7-element LED displays. This scrolling routine 560 is used in conjunction with the switch scanner routine 530 and depending upon whether the operator switch or the installer switch is set, established those functions which may be performed.

In particular, an installer is able to change system parameters such as assignment of sensor loops, output circuits and peripheral types. For each loop the installer can assign specific output linkages for output circuits, particularly relay positions for alarm conditions, while for peripherals, various security levels. An installer may also adjust all the various timing delays, for example entrance and exit delays, siren output and pause duration, and the operation of a real time clock.

An operator, however, may only inhibit and reenable the sensor loops, outputs, peripherals and the real time clock, and assign and cancel security card and cipher codes.

The time interrupt routine 570 operates under control of an internal 1 millisecond clock symbolized by subroutine block 574. The time interrupt in first place is used to control, as symbolized by subroutine block 571, among other things, the generation of audio signals at the alarm control center, such as the buzzer. By means of its subroutine module 572 the timer interrupt routine is coupled to the scrolling routine (as also indicated by a dotted interconnection line) in that it outputs and refreshes in a time multiplex fashion, the appropriate display digit or LED bit. By means of its subroutine module block 573 the time interrupt routine is also coupled to the remote bus processing routine 590 in that it controls the actual transmitting and receiving of data over the remote bus.

The auto test routine 580 is performed whenever a mode switching is required (e.g. from a "day" mode to a "night" mode) or under control of an operator or installer. During the routine, each sensor loop is forced into a high state for two scanning cycles by temporarily applying a higher-than nominal voltage by means not shown. Next, in similar manner a low state is applied for two scanning cycles and then the loop is allowed to assume its normal state. If any inconsistency occurs in the above testing or if a failure occurs in the battery, power supply, tamper switches or peripherals, switching from

day mode to night mode is inhibited. If required, an appropriate error message is displayed. A similar procedure is effected in case of other mode transitions.

The remote bus processing routine 590 forms the communication with the peripheral devices. The routine first checks whether there is an error in the received message. If so the routine discards the error message and communicates again with the peripheral device in question. Keeping track of the number of errors for the specific peripheral device, the remote bus processing routine 590 initiates an alarm call if a predetermined maximum is exceeded. Assuming the message is error free, the remote bus processing routine 590 updates the file for the particular peripheral device and appropriate processing procedures are initiated which include switching the system mode, indicating an alarm, or allowing a door to be opened.

In the event of the loss of line voltage or power supply failure, the remote bus processing routine 590 periodically stops and restarts remote bus communications. Each peripheral device 270 connected to the remote bus will then, through the use of the carrier loss detection circuit 279 contained therein, switch itself off thereby conserving battery power until the remote bus communications is restarted. In certain applications specific requirements must be fulfilled as imposed by a specific user. Block 591 is therefore reserved for user-defined software routines that would cooperate with further routines and or respective hard-ware facilities under control of Exec 500.

Fig. 8 provides in block diagram the organization of the software used for the peripheral devices. The system operation is controlled by a further Exec program 600. This Exec 600 has, in peripheral operation, a more limited role. Typically, a peripheral device may be a remote control unit designed to switch the system from day to night modes and back. Such a device would operate when a user inserted his coded key into the unit and turned it. The turning of the key would initiate a sequence which would provide, if the user leaves the premises at night, a visual display of those loops which would prevent proper operation, or loops which were previously inhibited by the user, or else a signal that the system was okay. Corresponding to Fig. 7, the Exec program 600 is reached from an initialization routine 605.

As modes are switched from day to night, this is signalled by LED's on the peripheral itself. The peripheral also generates an audio tone indicating that the user started the run counting of his exit delay. As the user opens doors to leave the premises, the audio tone changes in pitch so that the user knows that the system is functioning properly.

Incorporating these functions in a peripheral device, is handled by three routines called the scanning routine 610, the timer routine 620, and the remote bus processing routine 630.

5
10
15
20
25
30
35
40
45
50
55
60
65

A peripheral device is different from the alarm control center in that the scanning routine 610 scans both the input (relevant subroutine is symbolized by block 611) and the output (sub-routine symbolized by block 612), the only difference being the direction of scan. There is some limited processing of inputs in the peripheral devices, however major analysis of input signals from a peripheral device is performed by the alarm control center.

The timer program 620 in the peripheral has significance in that events are synchronized to system operation. There is a similar timing capability in the alarm control center, however it is incorporated as part of the scrolling routine 560, which is time synchronized to the external world.

As in the alarm control center, the peripheral device also contains a timer interrupt section 640. The timer interrupt 640 performs a similar function of audio generation, display generation and remote bus communication. It is the mirror image of the timer interrupt routine 570 in the alarm control center and has correspondingly a set-up with four sub-blocks (641, 642, 643, 644). A major difference however is the following. The timer interrupt routine 640 in the peripheral device must, by way of its internal timing subroutine block 644 be synchronized to the timer interrupt routine 570 of the alarm control center as has been shown in the figure. This is necessary to ensure proper data communication between the alarm control center and the peripheral device. Therefore, to ensure proper synchronization, the peripheral device utilizes the external interrupt to provide synchronization between the two units, within a few microseconds. This allows extremely reliable data communication on the remote bus 80, the remote bus communication routine 630 is linked to routine 643 in similar manner as are the routines 573/590 in Fig. 7.

System operation

The alarm control center is designed such that there are two levels of user interface, namely operator interface and installer interface, the normal operator interface to the system is used on entering and leaving the premises. When an owner of a store, which is protected by the alarm control center system, enters his premises, he initiates a procedure which switches his system from the night mode (full protection) to the day mode (reduced protection). This interface is handled through a remote control unit connected to the alarm control center. An alarm control center can handle up to 16 peripheral devices consisting of 9 different types. Each peripheral device has an individual address and an unique communication capability. Selection of the peripheral device requires an incorporation of it into the system which is the job of the skilled installer. As far as an operator is concerned, his interface has the primary function of day/night and night/day switching, and status display. In certain situations, more sophisticated capabilities

are provided such as card and cipher access control of selective areas, incorporation of electric strike locks and door strikes and using volume printers for remote camera control.

The operator switches the system by inserting his key into a remote device and turning his key. This initiates a sequence of events beginning with a test of the system status which ultimately leads to a display of the system condition at the time of key insertion, and, switching operating modes.

Similarly, when the operator leaves his premise at night he repeats the operation. He inserts his key into his remote control device, and if the display is proper, he leaves his premises. The system switches from "reduced protection" to "full protection" if all operational parameters are in accordance with predefined specifications.

In the event that there has been an alarm in the system, the operator is able to get preliminary information from his remote device, provided the particular device has the necessary display means. In any event, the operator can get full information by going to the alarm control center itself, inserting his operator key into the alarm control center and turning it. The system will display information which allows the operator to ascertain the nature of the problem.

The next level of user interface is the installer. In this case we have a higher level user. The installer requires more information from the system and also has more control over the alarm control center program. The installer normally sees the system as two different times. The first time is on initial installation. When the installer initially connects a system, he must perform individual installation of all the sensors necessary to protect the premises. He then proceeds to connect the wires to the alarm control center. Connection is done by an interconnection scheme which allows very rapid connection of individual wires into cable harnesses with connectors. The connectors allow rapid plug-in of sensor loops to the I/O board 100 inside the alarm control center. The installer at installation must connect the line voltage and battery to provide proper system operation. After a system has been wired in, it is necessary to check and align it. Checking alignment is automatically accomplished by the micro-processor contained in the alarm control center when the appropriate controls are pressed by the installer. In addition to checking and aligning the input loops, the alarm control center also forces the installer to step through all of the devices which he has the possibility of programming. This is done so that the installer knows what parameters are entered into the system and the alarm control center has the proper information to initiate its surveillance of the premises.

The second time the installer sees the system is when the user has a problem. In this case, the installer's information is similar to the user's information, namely the source of the problem. The major function which the installer uses is an automatic repeat viewing "walk test" of the individual loop creating problems.

Interfacing to the external environment is via two different types of interfaces. The first interface is the interface of peripheral devices connected to the alarm control center. This interface, the remote bus, is designed to work at aggregate distances of up to 500 meters. From 1 to 16 peripheral devices may be connected on the remote bus. Communication to peripheral devices utilizes synchronization to hardware interrupts between the alarm control center and the peripheral devices. Then communication begins with two modes of operation, namely individual peripheral addressing and group addressing. The two communication modes are intermixed so that fast response may be obtained to changes in individual peripheral status yet each peripheral may have its time for communication to establish full operational capability.

Communication to the external world is handled by a separate communications printed circuit board 300 which is mounted in the alarm control center. There is a possibility of using hierarchical communications modules. In the end it is designed that the alarm control center is able to be monitored programmed, and controlled by a central alarm station.

A different type of communication was necessary for the PTT interface as contrasted with the remote bus communications. This is because external communications requires a higher level of security since it is more vulnerable to attempts to damage the communications system. External communications use parity bits, block checking characters and echo back procedures to minimize the effect of noise and extraneous signals introduced into the communication line. Moreover, the alarm control center communications board 300 has the capability of providing encryption of the data to reduce the possibility of sabotage.

Claims

1. An alarm control center for interfacing with:
 - a. a plurality of input sensor loops (102), each of said loops having at least one sensor element, each sensor element having a respective electrical resistance range between a standard condition of an associated physical facility and a hazardous condition of such physical facility and
 - b. an array of alarm output elements (140) for outputting a plurality of respective audio-visual alarm signalizations,
 said alarm control center comprising:
 - 1.1 first means (510) for interchangeably preassigning respective alarm parameter values for each of said input sensor loops;
 - 1.2 second means for interchangeably preassigning respective alarm signalizations for each of said input sensor loops;
 - 1.3 scanning means (120) for sequentially scanning said plurality of input sensor loops;
 - 1.4 conditioning means (130) for conditioning the signals from each of the scanned sensor loops;

- 1.5 comparing means (520) for comparing the signal from each particular scanned input sensor loop with the corresponding pre-assigned alarm parameter value;
- 1.6 activating means (540, 555) for activating the associated alarm output elements under control of an output signal from said comparing means indicating a hazardous condition in the signal corresponding to the respective input sensor loop;
- 1.7 security level selecting means for selectively controlling a first security level mode of operation and a second security level mode of operation, wherein during the second security level mode all of said input sensor loops and alarm elements are operational while during the first security level mode certain of said input sensor loops and alarm outputs are inhibited,

characterized in that cycling means (580) are provided for automatically and conditionally controlling transitions between said respective modes at appropriate instants under the express condition of absence of an alarm condition signal at a said appropriate instant, but for inhibiting a transition upon presence of an alarm condition signal.

2. An alarm control center as claimed in claim 1, which furthermore comprises interface means (300) for receiving and operatively forwarding remotely originated control signals for controlling said scanning means, said comparing means, and said alarm activating means.

3. An alarm control center as claimed in claim 1 or 2, which furthermore comprises remote station means coupled to said interface means and having selector means for generating under external control activation/deactivation signals for further elements of said alarm control center.

4. An alarm control center as claimed in any of the claims 1 to 3, furthermore comprising a scanning selector (520) for under control of a warning signal selectively increasing the scanning rate of at least one particular input sensor loop with respect to its standard scanning rate for verifying the occurrence of an alarm condition in said at least one particular input sensor loop.

5. An alarm control center as claimed in any of the claims 1 to 4 which further comprises back-up battery (460) means for powering said alarm control signal under control of a signalling signal produced by a power outage sensor coupled to a mains-fed power supply means.

6. An alarm center as claimed in claim 5 which furthermore comprises secondary cycling means (590) repetitively switching on and off a remote station means coupled to said alarm control center under battery-powered conditions for extending battery operation time.

7. An alarm control center as claimed in claim 6, further comprising suspending means (279, 530) for under control of a low voltage condition of said battery back-up means suspending the

operation of said alarm control center for preventing excessive discharge of said back-up battery means.

5 Patentansprüche

1. Alarmsteuerzentrum zum Anschliessen an
 a. eine Anzahl von Eingangssensorschleifen (102) mit je zumindest einem Sensorelement, das je einen jeweiligen elektrischen Widerstandsbereich zwischen einem Normalzustand einer zugeordneten physikalischen Einrichtung und einem ungewissen Zustand einer durartigen physikalischen Einrichtung und
 b. eine Reihe von Alarmausgangselementen (140) zum Ausgeben einer Anzahl jeweiliger audio-visueller Alarmsignalisierungen;

wobei das Alarmsteuerzentrum folgende Mittel enthält:

- 1.1 Erste Mittel (510) für die austauschbare Zuordnung jeweiliger Alarmparameterwerte zu einer jeden der Eingangssensorschleifen;
- 1.2 zweite Mittel für die austauschbare Zuordnung jeweiliger Alarmsignalisierungen zu jeder der vorherigen Eingangssensorschleifen;
- 1.3 Abtaster (120) für die aufeinanderfolgende Abtastung der Anzahl von Eingangssensorschleifen;
- 1.4 Konditionierungsmittel (130) zum Konditionieren der Signale aus einer jeden der abgetasteten Sensorschleifen;
- 1.5 Komparatoren (520) zum Vergleichen des Signals aus jeder einzelnen abgetasteten Eingangssensorschleife mit dem entsprechenden vorher zugeordneten Alarmparameterwert;
- 1.6 Aktivierungsmittel (540, 555) zum Aktivieren der zugeordneten Alarmausgangselemente unter der Steuerung eines Ausgangssignals aus den Komparatoren, die eine unsichere Bedingung im Signal entsprechend der jeweiligen Eingangssensorschleife angeben;
- 1.7 Sicherheitspegelwählmittel zum selektiven Steuern einer ersten Sicherheitspegelbetriebsart und einer zweiten Sicherheitspegelbetriebsart, wobei während der zweiten Sicherheitspegelbetriebsart alle Eingangssensorschleifen und Alarmentelemente betriebsbereit sind, während bei der ersten Sicherheitspegelbetriebsart bestimmte Eingangssensorschleifen und Alarmausgänge blockiert sind,

dadurch gekennzeichnet, dass Durchlaufmittel (580) zum selbsttätigen und bedingten Steuern von Übergängen zwischen den jeweiligen Betriebsarten zu geeigneten Zeitpunkten unter der ausdrücklichen Bedingung der Abwesenheit eines Alarmzustandssignal zu einem geeigneten

Zeitpunkt, jedoch zur Blockierung eines Übergangs beim Auftreten eines Alarmzustands-signals vorgesehen sind.

2. Alarmsteuerzentrum nach Anspruch 1, dadurch gekennzeichnet, dass weiter im Alarmsteuerzentrum Schnittstellen (300) zum Empfangen und betriebsmässigen Weiserleiten fernübertragener Steuersignale zum Steuern der Abtastmittel, Komparatoren und Alarmaktivierungsmittel vorgesehen sind.

3. Alarmsteuerzentrum nach Anspruch 1 oder 2, dadurch gekennzeichnet, dass das Zentrum weiter Fernstationen in Verbindung mit den Schnittstellen enthält und Selektoren zum Erzeugen von Aktivierungs/Entaktivierungssignalen unter externer Steuerung für weitere Elemente des Alarmsteuerzentrums aufweist.

4. Alarmsteuerzentrum nach einem oder mehreren der Ansprüche 1 bis 3, dadurch gekennzeichnet, dass das Zentrum weiter einen Abtastselektor (520) zum Erhöhen der Abtastgeschwindigkeit zumindest einer speziellen Eingangssensorschleife in bezug auf ihre Normalabtastgeschwindigkeit unter der Steuerung eines Warnsignals zum Feststellen eines Alarmzustands in der zumindest einen besonderen Eingangssensorschleife.

5. Alarmsteuerzentrum nach einem der Ansprüche 1 bis 4, dadurch gekennzeichnet, dass das Zentrum weiter einer Reservebatterie (460) zur Verstärkung des Alarmsteuersignals unter der Steuerung eines Signalisierungssignals aus einem Stromausfallsensor in Verbindung mit einem netzgespeisten Stromversorgungsgerät enthält.

6. Alarmsteuerzentrum nach Anspruch 5, dadurch gekennzeichnet, dass das Zentrum weiter sekundäre Durchlaufmittel (590) zum wiederholten Ein- und Ausschalten eines Fernstationen in Verbindung mit dem Alarmsteuerzentrum unter batteriegespeisten Bedingungen zur Erweiterung der Batteriebetriebszeit enthält.

7. Alarmsteuerzentrum nach Anspruch 6, dadurch gekennzeichnet, dass das Zentrum weiter Blockierungsmittel (279, 530) zum Blockieren des Betriebs des Alarmsteuerzentrums unter der Steuerung eines Niederspannungszustands der Reservebatterie zur Verhinderung einer zu grossen Entladung der erwähnten Reservebatterie enthält.

Revendications

1. Centre de commande d'alarme à connecter à:
a. plusieurs boucles de capteurs d'entrée (102), chacune de ces boucles comportant au moins un élément capteur, chaque élément capteur présentant un intervalle de résistance électrique correspondant entre un état standard d'un moyen physique associé et un état dangereux de ce moyen physique, et

b. un ensemble d'éléments de sortie d'alarme (140) pour produire plusieurs signaux d'alarme audiovisuels correspondants,

le centre de commande d'alarme comprenant:

- 1.1 un premier moyen (510) pour préattribuer de manière interchangeable des valeurs paramétriques d'alarme correspondantes pour chacune des boucles de capteurs d'entrée,
- 1.2 un second moyen pour préattribuer de manière interchangeable des signaux d'alarme correspondants pour chacune des boucles de capteurs d'entrée;
- 1.3 un dispositif de balayage (120) pour balayer de manière séquentielle les diverses boucles de capteurs d'entrée;
- 1.4 un dispositif conditionneur (130) pour conditionner les signaux provenant de chacune des boucles de capteurs balayés;
- 1.5 un dispositif comparateur (520) pour comparer le signal provenant de chaque boucle de capteur d'entrée balayée particulière à la valeur paramétrique d'alarme préattribuée correspondante;
- 1.6 un dispositif d'activation (540, 555) pour activer les éléments de sortie d'alarme associés sous la commande d'un signal de sortie du dispositif comparateur indiquant un état dangereux dans le signal correspondant à la boucle de capteur d'entrée correspondante;
- 1.7 un dispositif sélecteur de niveau de sécurité pour commander sélectivement un mode de fonctionnement à un premier niveau de sécurité et un mode de fonctionnement à un second niveau de sécurité, dans lequel, pendant le mode du second niveau de sécurité, toutes les boucles de capteurs d'entrée et les éléments d'alarme sont opérationnels tandis que, pendant le mode du premier niveau de sécurité, certaines boucles de capteurs d'entrée et certains éléments de sortie d'alarme sont bloqués;

caractérisé en ce que des moyens de cyclage (580) sont prévus pour commander automatiquement et conditionnement des transitions entre les modes correspondants à des moment appropriés, à la condition expresse qu'un signal d'état d'alarme soit absent à un moment approprié, mais pour bloquer une transition si un signal d'état d'alarme est présent.

2. Centre de commande d'alarme suivant la revendication 1 qui comprend, en outre, une interface (300) destinée à recevoir et à transmettre activement des signaux de commande provenant d'une certaine distance pour commander le dispositif de balayage, le dispositif comparateur et le dispositif activateur d'alarme.

3. Centre de commande d'alarme suivant la revendication 1 ou 2 qui comprend, en outre, un poste à distance couplé à l'interface et comportant un dispositif sélecteur pour produire, sous une commande externe, des signaux d'activation/désactivation pour d'autres éléments du centre de commande d'alarme.

4. Centre de commande d'alarme suivant l'une

quelconque des revendications 1 à 3 comprenant, en outre, un sélecteur de balayage (520) pour, sous la commande d'un signal d'avertissement, augmenter sélectivement la vitesse de balayage d'au moins une boucle de capteur d'entrée particulière par rapport à sa vitesse de balayage standard afin de vérifier l'apparition d'un état d'alarme dans au moins ladite boucle de capteur d'entrée particulière.

5. Centre de commande d'alarme suivant l'une quelconque des revendications 1 à 4 qui comprend, en outre, une batterie de secours (460) destinée à produire le signal de commande d'alarme sous la commande d'un signal de signalisation produit par un détecteur de panne de courant couplé à un dispositif d'alimentation de courant alimenté par le secteur.

5

10

15

20

25

30

35

40

45

50

55

60

65

11

6. Centre de commande d'alarme suivant la revendication 5 qui comprend, en outre, un dispositif de cyclage secondaire (590) pour enclencher et déclencher de manière répétitive un poste situé à distance couplé au centre de commande d'alarme dans des conditions d'alimentation par des batteries pour prolonger la durée de vie des batteries.

7. Centre de commande d'alarme suivant la revendication 6 comprenant, en outre, un dispositif de suspension (279, 530) pour, sous la commande d'un état de basse tension de la batterie de secours, suspendre le fonctionnement du centre de commande d'alarme afin d'empêcher une décharge excessive des batteries de secours.

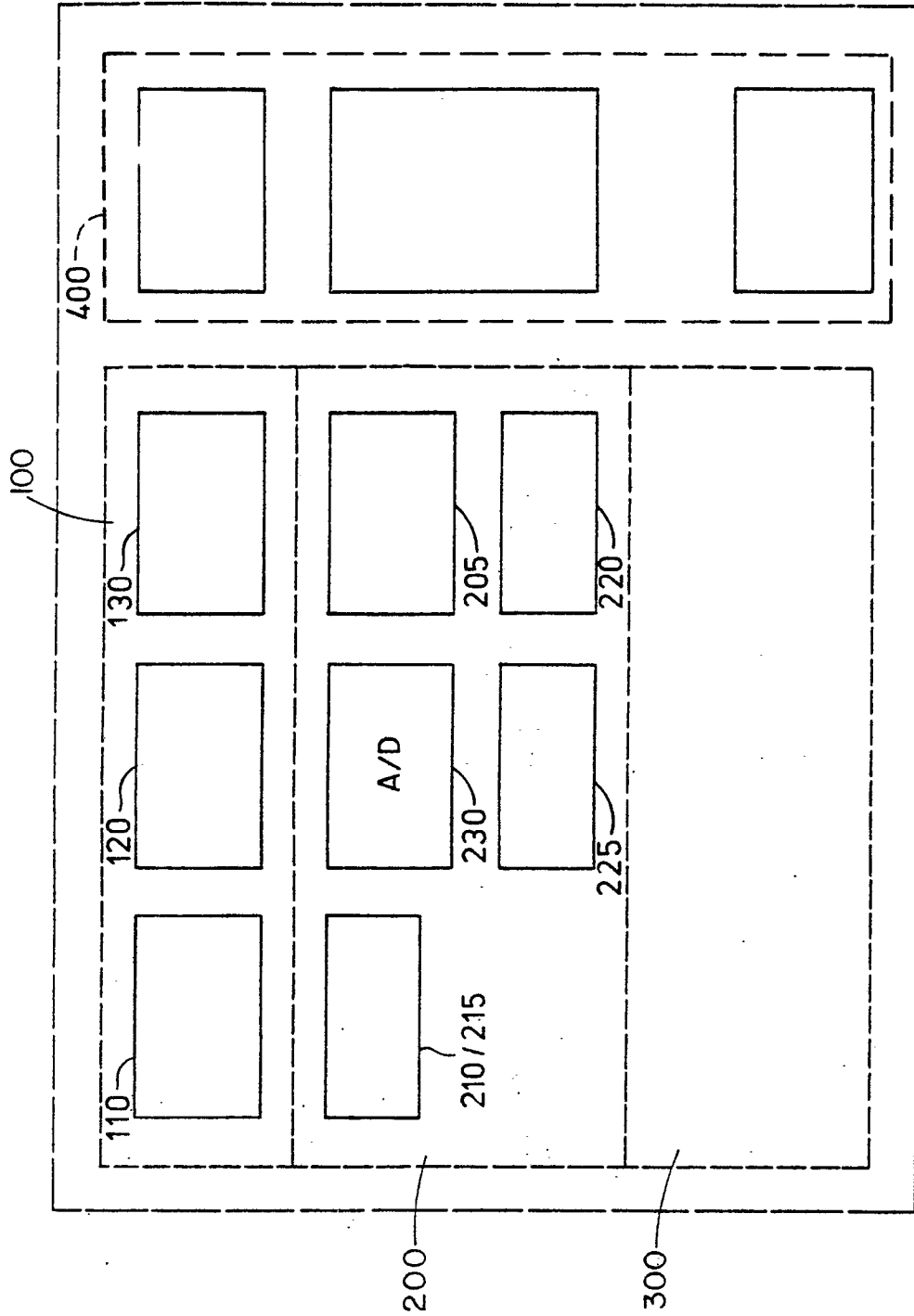

Fig. 1

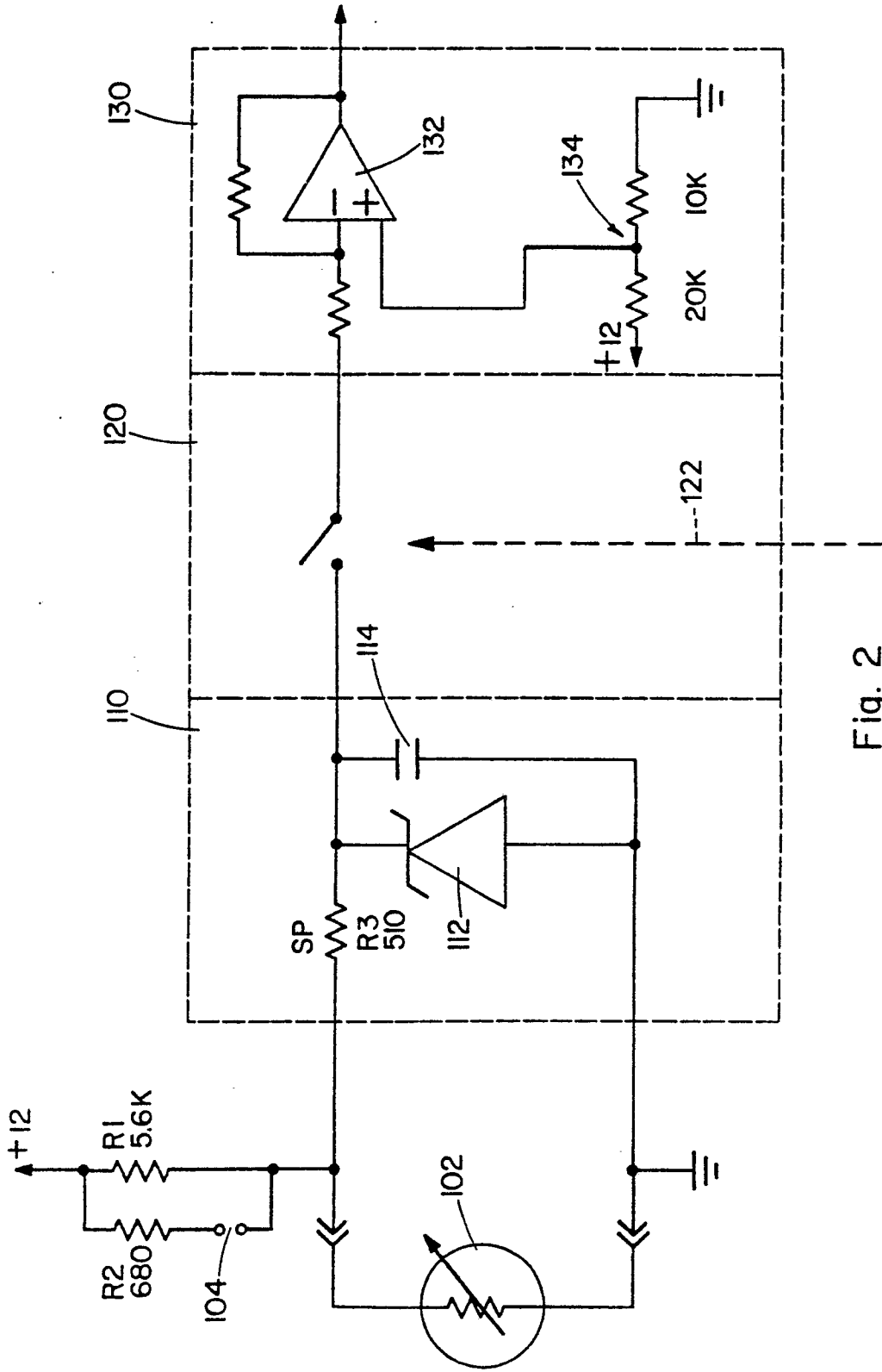

Fig. 2

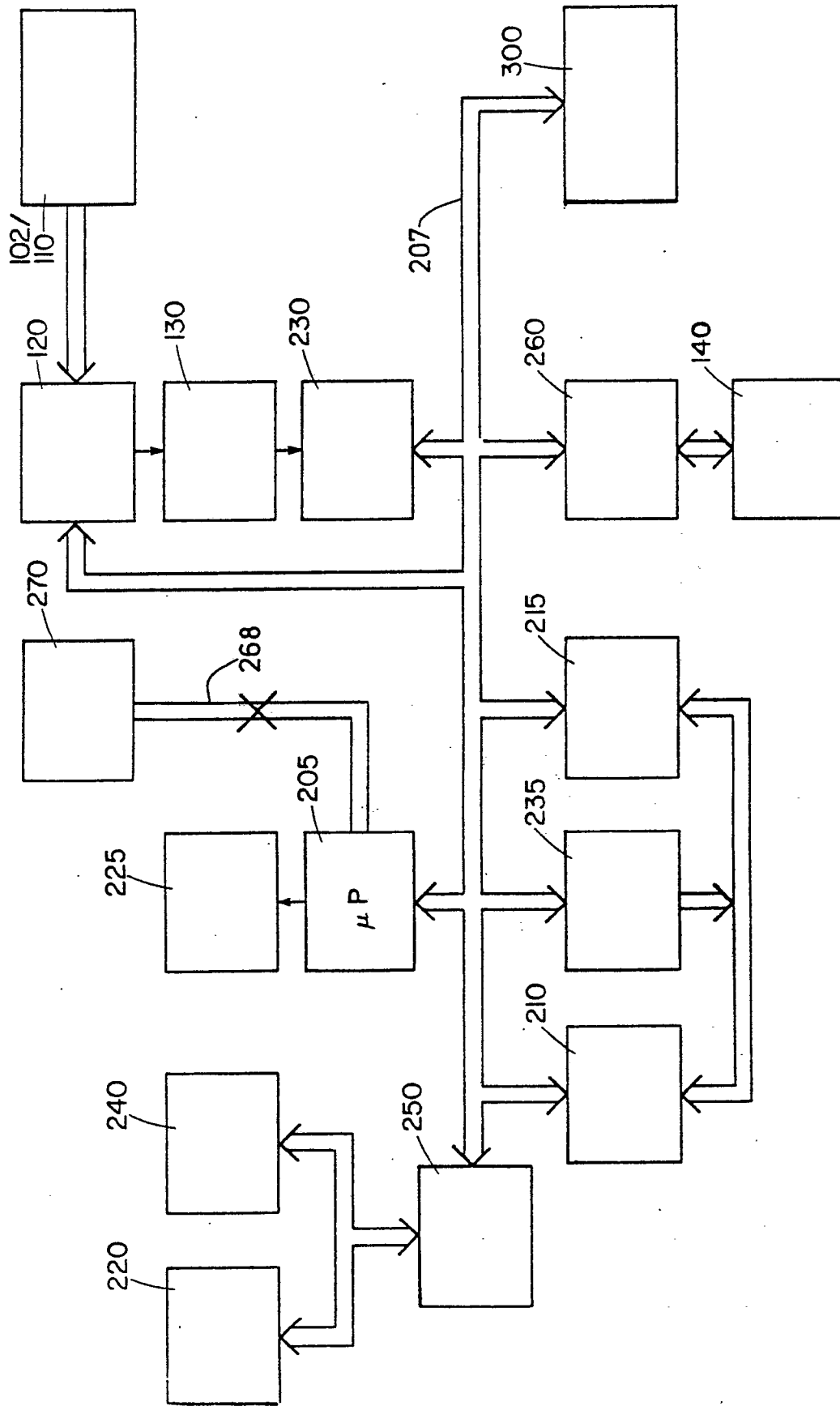

Fig. 3

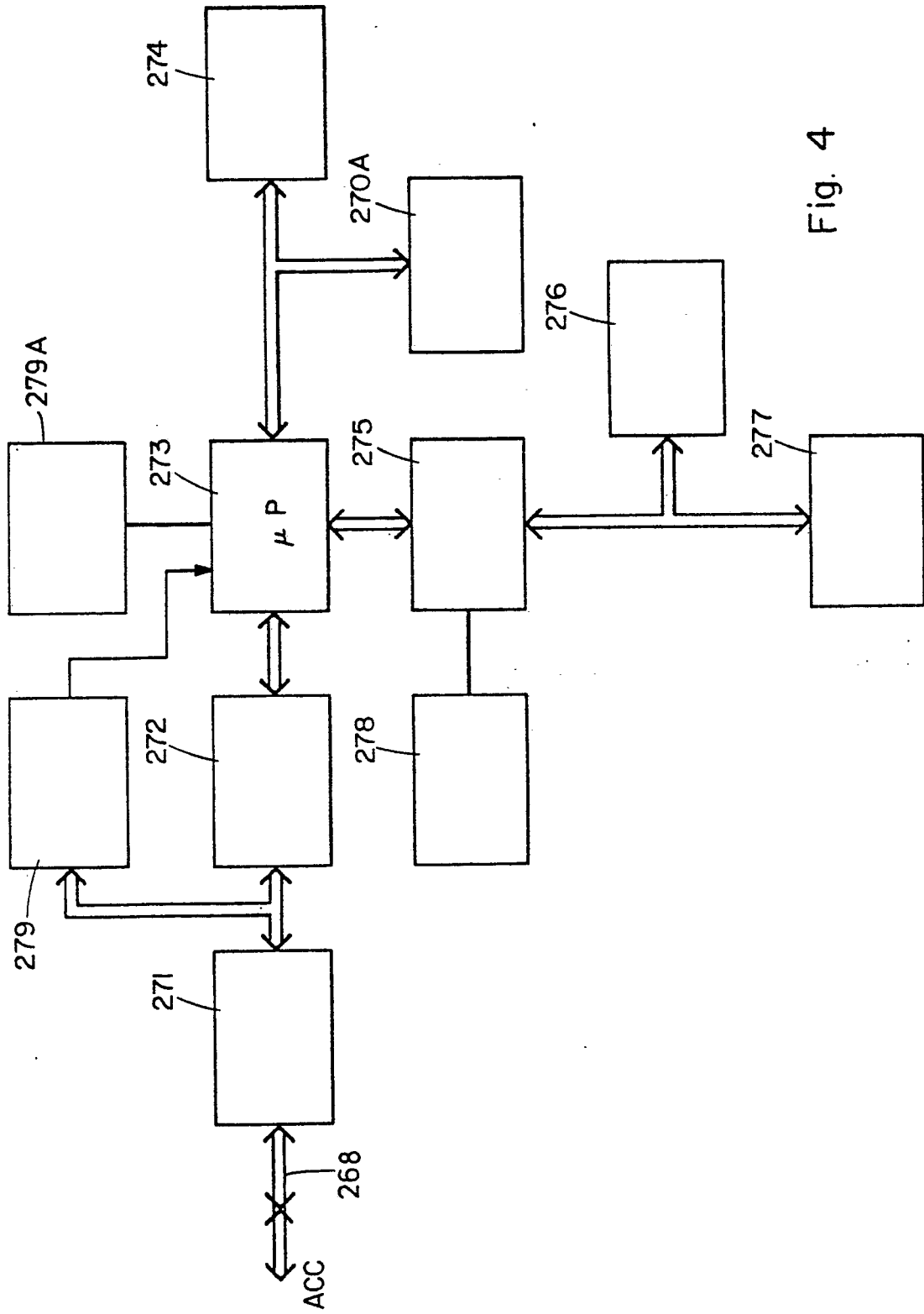

Fig. 4

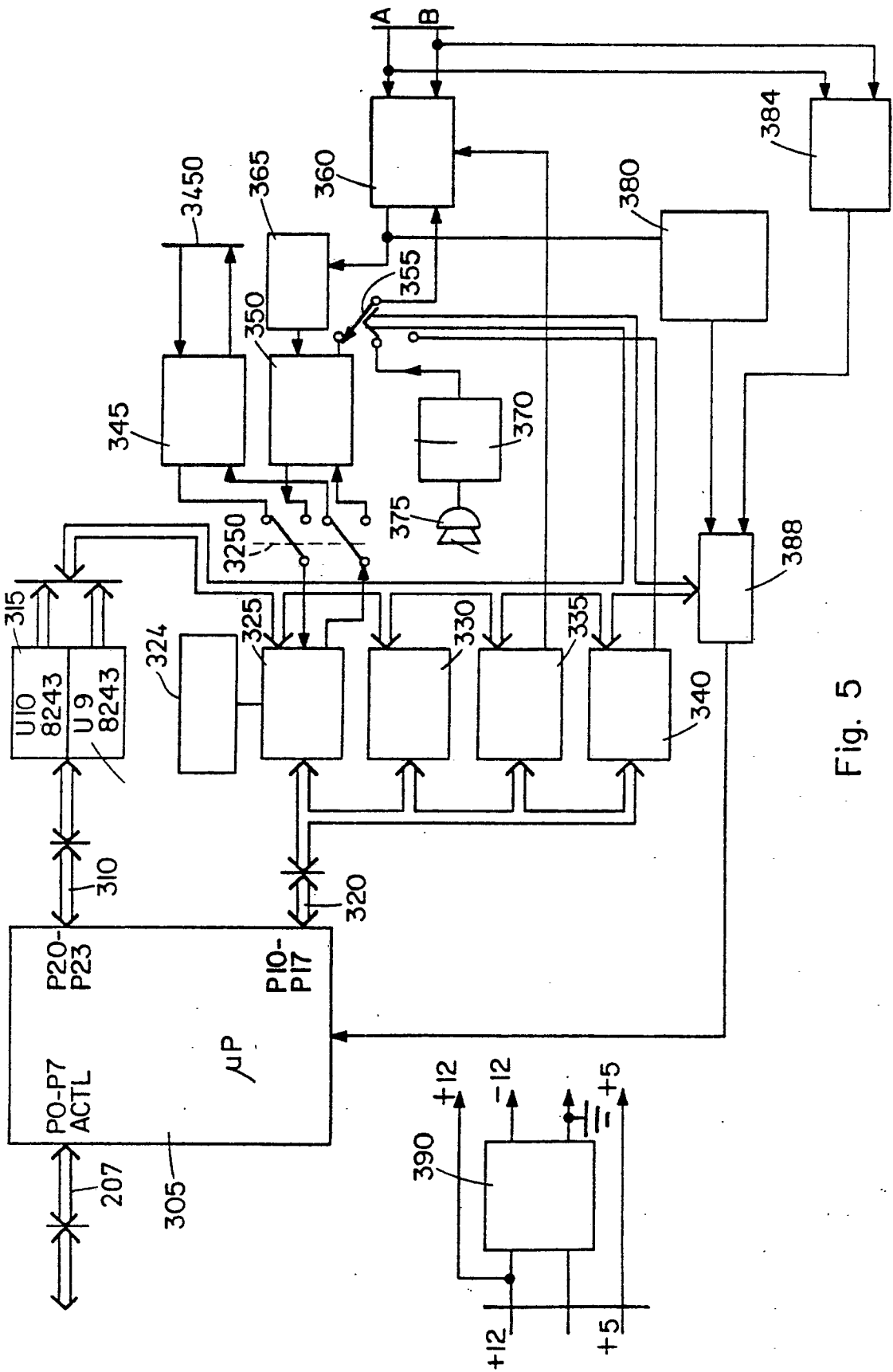

Fig. 5

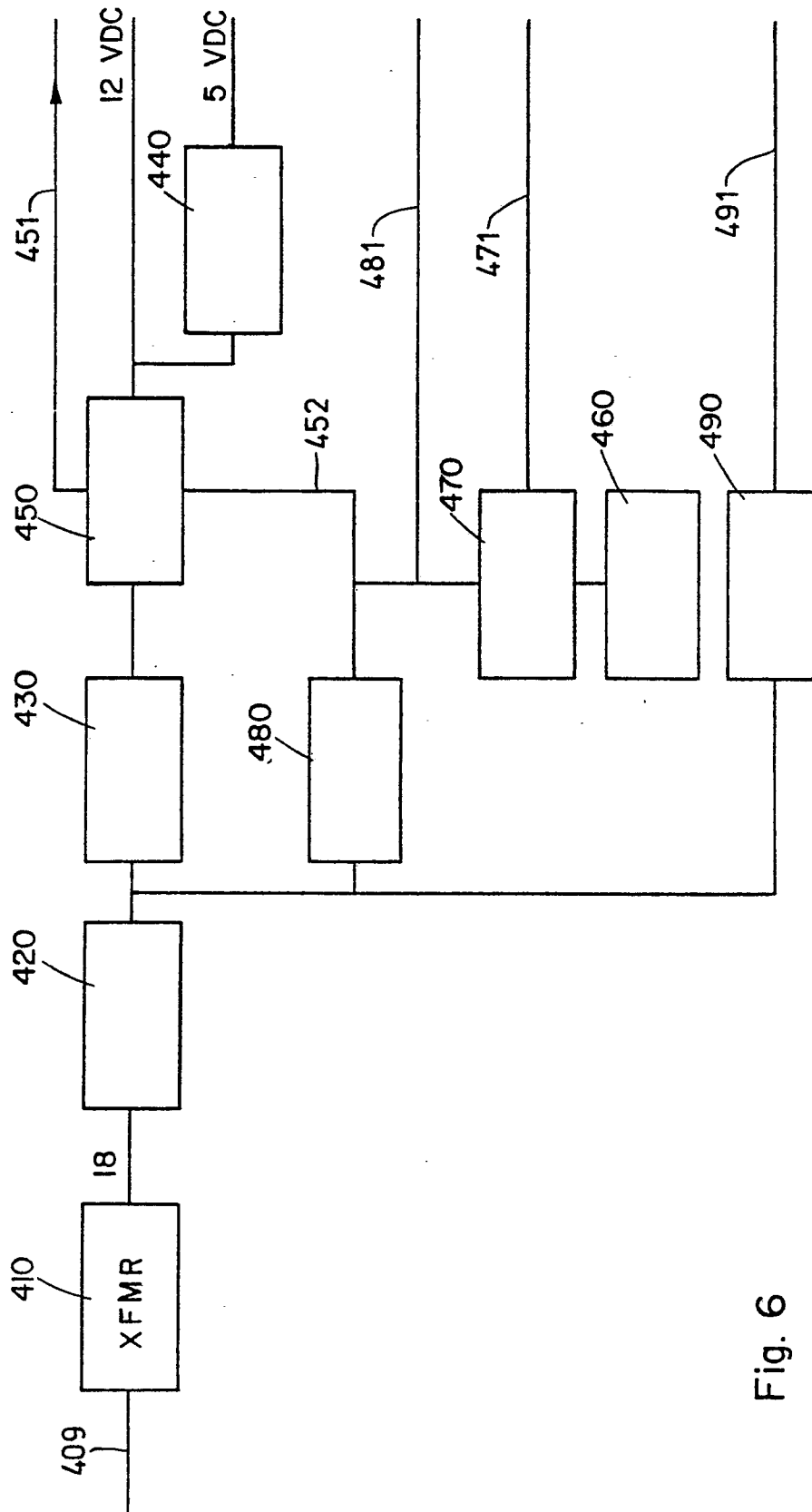

Fig. 6

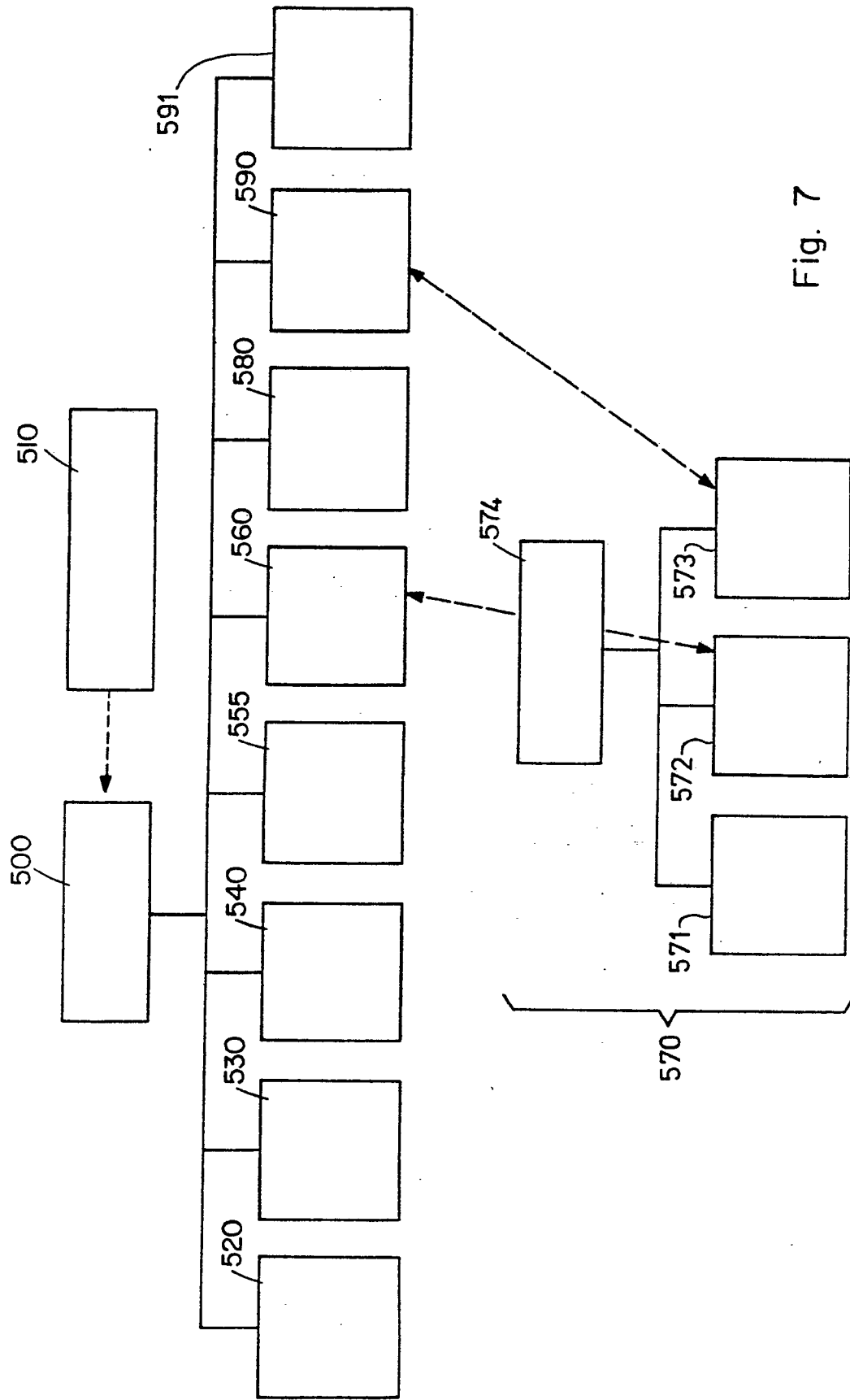

Fig. 7

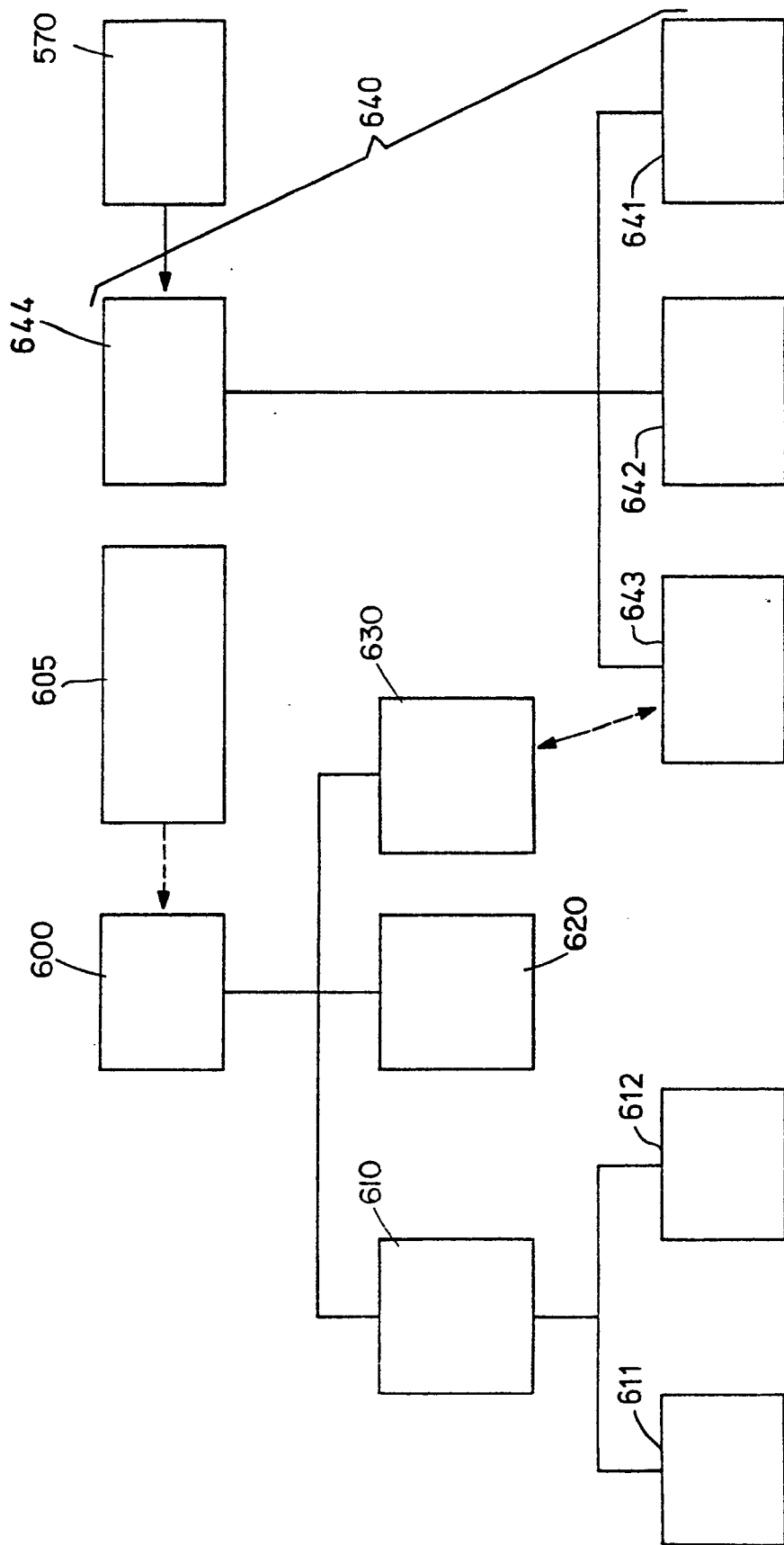

Fig. 8