

Aug. 27, 1963

V. MUTTART  
LOCK ASSEMBLY

3,101,965

Original Filed July 23, 1957

2 Sheets-Sheet 1

Fig. 1.

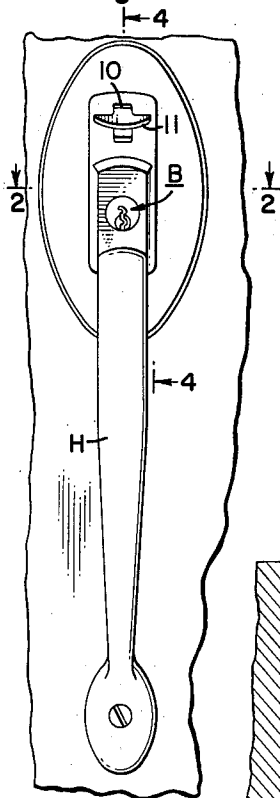

Fig. 2.

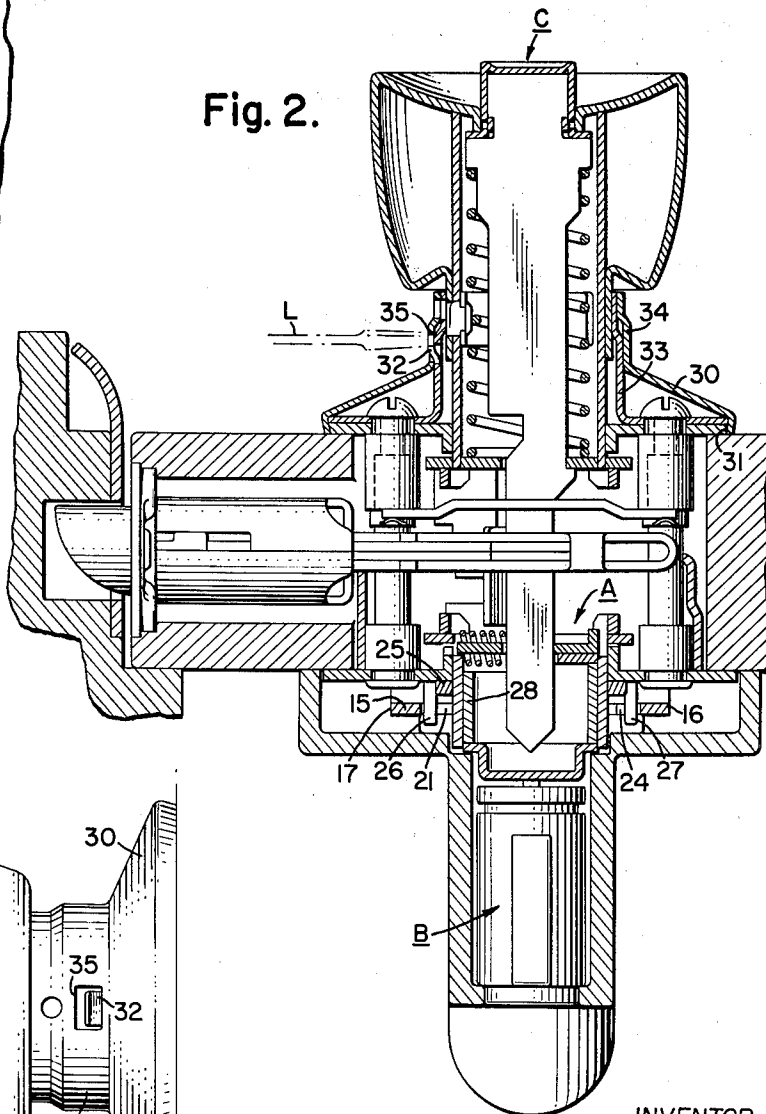
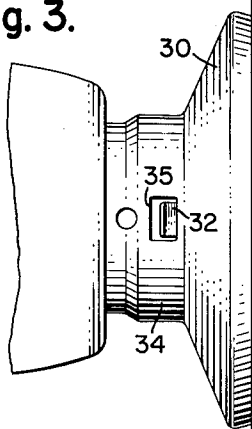

Fig. 3.



BY

INVENTOR  
VINCENT MUTTART

*Mark T. Basseches*

ATTORNEY

Aug. 27, 1963

V. MUTTART  
LOCK ASSEMBLY

3,101,965

Original Filed July 23, 1957

2 Sheets-Sheet 2

Fig. 4.

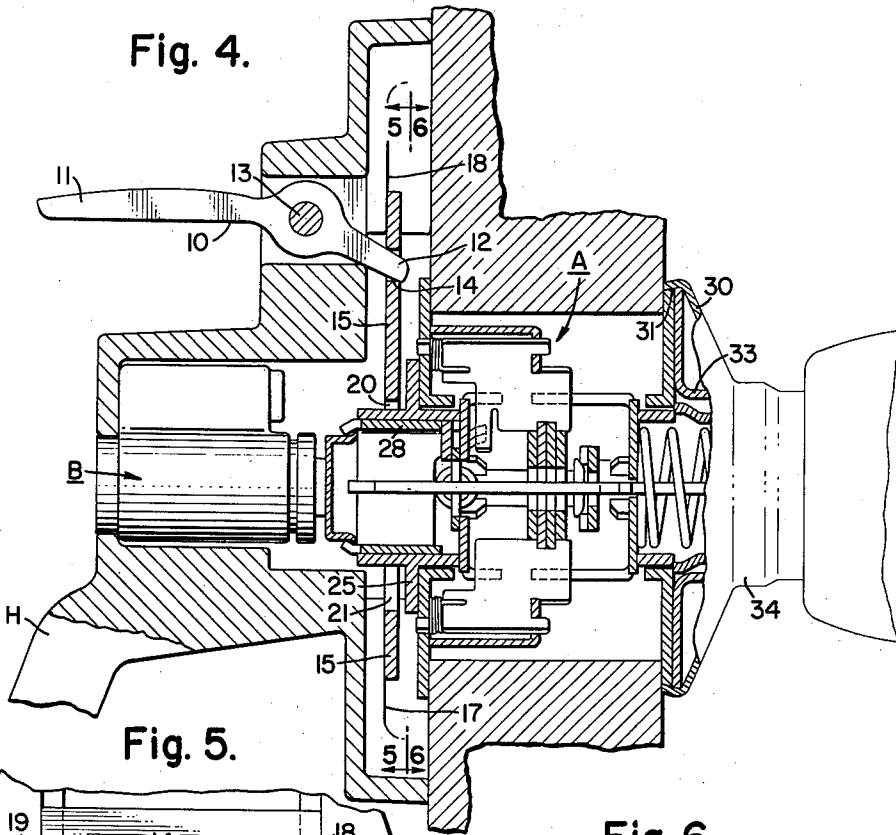

Fig. 5.

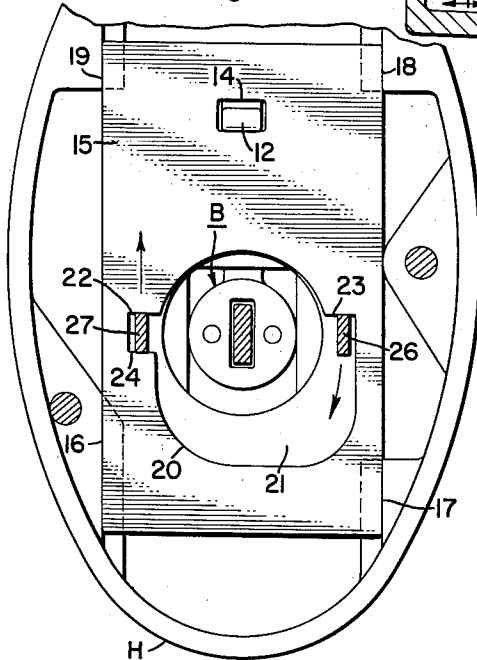
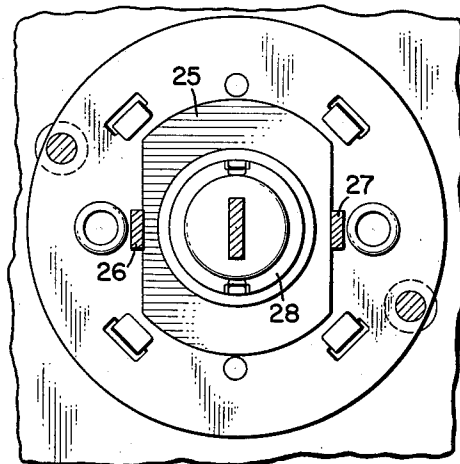

Fig. 6.



INVENTOR  
VINCENT MUTTART  
BY *Mark T. Basseches*  
ATTORNEY

1

3,101,965

**LOCK ASSEMBLY**

Vincent Muttart, Downey, Calif., assignor to Independent Lock Company, Fitchburg, Mass., a corporation of Massachusetts

Original application July 23, 1957, Ser. No. 673,591, now Patent No. 2,976,072, dated Mar. 21, 1961. Divided and this application Nov. 3, 1960, Ser. No. 70,870  
2 Claims. (Cl. 292—357)

This invention relates to cylindrical locks, and particularly to cylindrical locks of the type known as exit locks by reason of their frequent use upon the front doors of houses. More particularly, this invention relates to a cylindrical exit lock with a latch aperture assembly, knob operated from the inside and provided with a novel thumb lever mechanism for operation from the outside.

Still more particularly, this invention relates to a cylindrical exit lock having mounted on the inside door face a latch operating knob and a dogging push button or turnbutton and having mounted on the outside door face a novel thumb lever mechanism controlling the latch bolt when the pushbutton or turnbutton is in undogged position, and a key controlled mechanism capable of withdrawing the latch bolt independently of the position of the pushbutton or turnbutton.

This invention relates further to an assembly as above described which includes a rapidly demountable escutcheon plate.

As this invention is particularly well adapted for use with a cylindrical lock assembly in accordance with my copending application Serial No. 645,774, filed March 13, 1957, now Patent No. 2,966,054, granted December 27, 1960, I have illustrated my invention as used in conjunction therewith, but it should be understood that my invention may be adapted to various other lock assemblies, without departing from the spirit thereof.

Known to me are various lock assemblies employing a thumb lever as the mode of withdrawing the latch bolt. While no purpose would be served in now reviewing such known assemblies, I shall summarize the disadvantages most commonly experienced in their use.

Since it is at once apparent that the "throw" or arcuate distance which a thumb actuated lever can travel is relatively small as compared with the circumferential distance normally travelled by a rotating knob, some magnification of movement has heretofore been necessary to adapt a cylinder lock to thumb operation. Such magnification has frequently been accomplished by providing a thumb lever assembly with a fractional mechanical advantage. The disadvantages of such arrangement are obvious since the counterforces, such as latch bolt spring pressure and sliding friction, operating to retard latch withdrawal, are magnified. To overcome such magnified forces, it is necessary to exert thumb pressures, sometimes of a magnitude to render normal operation painful and difficult, if not impossible, particularly to some women and children.

A further fault commonly found in conventional thumb operated latch assemblies is the cumbersome and costly structure provided for communicating thumb leverage to the latch bolt assembly. Aside from the increased expense attendant upon producing such assemblies, I have determined that additional frictional resistance is encountered, thereby contributing further to the problem previously noted.

It has been common in known assemblies to provide the thumb lever with an individual spring for returning such lever to its normal position. It will be apparent that an assembly utilizing such spring will be more difficult to use than if such spring were eliminated.

2

Known assemblies of the type described have been commonly "handed" for use upon either right hand or left hand opening doors, it being necessary for the manufacturer to provide, and the distributor to maintain, quantities of each of the two types of assemblies.

It is accordingly an object of my invention to provide a thumb operated lock assembly wherein the pressure needed for bolt retraction is minimized by allowing the use of a multiplying mechanical advantage for the thumb lever. A further object of my invention is to provide a thumb actuated lock assembly utilizing a simple friction minimizing link between the thumb lever and the latch bolt retracting assembly.

Still a further object of my invention is to provide an assembly wherein gravitational forces are advantageously employed and, in a measure, eliminate the necessity for additional springs to return the thumb lever to the normal position, the projecting springs utilized to operate the latch bolt being adapted primarily to perform this function and effect economies in installation and assembly.

Still another object of my invention is to provide a thumb actuated lock assembly which, by simple adjustment of the parts, may be adapted to be "handed" for use on either a right hand or a left hand opening door.

Another object of my invention is to provide a quickly demountable escutcheon for an assembly of the type described.

To attain these objects and such further objects as may appear herein or be hereinafter pointed out, I make reference to the accompanying drawing forming a part hereof, in which—

FIGURE 1 is a front elevation of the outer portion of my device, as it appears in operation;

FIGURE 2 is a magnified section taken on the line 2—2 of FIGURE 1;

FIGURE 3 is a magnified fragmentary plan view of an escutcheon plate in accordance with my invention;

FIGURE 4 is a magnified section taken on the line 4—4 of FIGURE 1;

FIGURE 5 is a section taken on the line 5—5 of FIGURE 4;

FIGURE 6 is a section taken on the line 6—6 of FIGURE 4.

For convenience in understanding my invention, reference is made to my copending aforementioned application to exemplify a rotationally actuated, spring projected latch bolt assembly with which my thumb lever mechanism may be employed, and with which the specific thumb operated mechanism is particularly valuable in transposing movements of small magnitude to effect substantial retraction movement readily.

In the novel thumb operating assembly to which this invention is directed, a lever 10, having an exterior thumb actuated branch 11 and an interior branch 12 is pivoted about a fulcrum 13 supported on the outer escutcheon casing and integral handle H affixed to the outer face of the door.

The interior branch 12 extends inwardly to engage a seat 14 formed transversely through a communicating plate 15. The plate 15 is guided to be slidable in a vertical plane by the shoulders 16, 17, 18 and 19 defined by the casing. The plate 15 has an extended recess 20 formed therethrough asymmetrical to the vertical axis and comprising a large central clearance portion 21 asymmetrical with respect to the vertical axis. At the upper portion of the recess 21 there are provided upper lateral shoulder portions 22 and 23 and a lower lateral shoulder 24.

The latch bolt retractor mechanism, referred to generally as A, is provided with an outer plate 25 from which extends the upturned lugs 26 and 27. It should

be understood that rotation of the plate 25 serves to withdraw the latch bolt, the operation of said withdrawal being more fully described in my copending application heretofore referred to, as an example of a rotary transmission expedient which is preferred because of the novel motion magnifying relationship.

The latch bolt may likewise be withdrawn by the action of the independently, concentrically located spindle 28 which is operatively connected to the key plug assembly B, as shown in my aforesaid prior filed application.

It should be noted that when the lock assembly is dogged by actuation of the push button dogging assembly, generally referred to as C, latch bolt withdrawal may be effected only by operation of the key plug assembly B, it being understood that the thumb actuating assembly is useful only when the push button C is in the undogged position shown in FIGURE 2. In this position, depression of the thumb branch 11 pivots the lever 10 about the fulcrum 13, swinging the branch 12 arcuately upward. The above action serves to impart a vertical upward sliding movement to the plate 15 (see the arrow, FIGURE 5), sidewise slipping of the plate being prevented by the action of the four guide shoulders 16, 17, 18 and 19. Upward movement of the slide plate 15 communicates to the actuating plate 25 a rotary motion, due to the coaction of the shoulder 24 with the lug 27, thereby operating the latch retractor mechanism A and withdrawing the latch bolt. The lug 26 is permitted, by the nature of the lug clearance recess 21, to swing freely during said upward movement, without interference from the periphery of the walls defining the said recess.

It should be noted that the recess 21 is formed with an extended central portion to provide for the passage through the recess of portions of the key plug assembly, said recess being of a size to prevent contact of the plate 15 with any portion of the plug assembly B, yet limiting the eccentricity of the slide plate 15 and lug on the plate 25 to prevent binding.

As heretofore mentioned, it is often necessary to change the "handing" of the door lock assembly. In order to accomplish such change, it is merely necessary to remove the plate 15 from the escutcheon assembly and rotate it 180° about its vertical axis, again positioning the seat 14 over the inner branch 12. In this inverted position, it will be noted that the shoulders 22, 24 will now envelope the lug 26 and the shoulder 23 abuts the lug 27. When the thumb 10 is depressed with the plate 15 thus reversed, the inner plate 25 will be rotated in the direction opposite to that in which it moved with the plate 15 in the former position, and the "handing" of the door thus easily changed.

The inside escutcheon of my assembly is adapted to be quickly demounted without running the risk of scuffing or scratching. To provide such quick demountability, the escutcheon plate 30 is frictionally, resiliently rotated on a seat 31, secured to the inner face of the door. An abutment lug 32 extends outwardly from a portion of the inner latch mounting base 33. The escutcheon plate 30 is provided with an inwardly extending collar 34, having a keeper shoulder 35 defined by a recess formed in the wall thereof. The shoulder 35 and the abutment 32, in the mounted position of the plate, are in approximately superimposed, transversely separated position, thereby permitting the insertion therebetween of a pry or lever L (see FIGURE 2), such as the bit of a screw driver.

It will be readily recognized that when such pry or lever L is inserted and twisted, the escutcheon plate 30 will be forced transversely outwardly, thereby quickly demounting it from the seat 31.

By this construction, an efficient, decorative and inexpensive thumb operated assembly is provided, having the advantages of smooth and easy operation, with minimal friction and wear.

By obviating the necessity for separate spring biasing operation on a motion magnifying lever, my assembly facilitates thumb actuation of the point where persons with only limited strength are able facilely to withdraw the latch bolt and in one case does the lever assume a dead center position.

The readily changeable or reversible "handing" feature permits the use of my assembly, without special tools, on doors which open in either direction, and obviates the necessity for supplying and storing latch assemblies limited to use on doors of either right or left "hand."

The escutcheon demounting feature of my invention is adapted to facilitate an operation which formerly was not only time-consuming but was a frequent source of irritation by reason of the likelihood, in other assemblies, of marring the fine finish of the plate in removing the same.

This application is a division of my application Serial No. 673,591, filed July 23, 1957 for Lock Assembly, now Patent No. 2,976,072, granted March 21, 1961.

Having thus described my invention and illustrated its use, what I claim as new and desire ot secure by Letters Patent, is:

1. In a cylindrical lock assembly adapted to be mounted in a bore hole transversely through a door, said assembly including a mounting base and an escutcheon seat, an escutcheon plate resiliently retained thereon by a snap-on fit, comprising a peripherally extended annular flange arranged to nest over said seat whereby said escutcheon plate covers said hole, the combination having quick demounting means for said escutcheon plate, said escutcheon plate having a collar portion and said mounting base having an extension over which said collar of said escutcheon plate may be sleeved, an abutment lug on said extension and a keeper shoulder on said collar defined by a cutout on said collar, said abutment lug and said shoulder being arranged to be axially and radially aligned when said escutcheon plate is snapped on in positiion on said seat, said shoulder extending in spaced relation to said abutment lug to facilitate disconnection of said escutcheon plate from said seat by application of leverage between said keeper shoulder and abutment lug, whereby marring of the door escutcheon is minimized.

2. In a cylindrical lock assembly adapted to be mounted in a hole bored transversely through a door, said assembly including a base having an escutcheon seat and an escutcheon plate resiliently retained by said seat in alignment over said hole by a snap-on fit of said plate over said seat, quick demounting means for said escutcheon plate comprising a cutout formed in said escutcheon plate providing a keeper shoulder on said escutcheon plate, said shoulder being directed toward said base, an abutment lug on said base, said keeper shoulder lying, in the mounted position of said plate on said seat, in proximate, axially aligned, outwardly spaced relation to said lug whereby a prying tool inserted between said shoulder and lug and operated to shift said shoulder away from said lug, will shift said escutcheon plate outwardly away from said base to demount said plate from said base.

References Cited in the file of this patent

UNITED STATES PATENTS

1,653,513	Schlage	Dec. 20, 1927
2,297,077	Schlage	Sept. 29, 1942