

(12) UK Patent Application (19) GB (11) 2 275 958 (13) A

(43) Date of A Publication 14.09.1994

(21) Application No 9402179.7  
(22) Date of Filing 04.02.1994  
(30) Priority Data  
(31) 9302287 (32) 05.02.1993 (33) GB

(71) Applicant(s)  
Ultraframe Plc  
  
(Incorporated in the United Kingdom)  
  
Enterprise Works, Salthill Road, CLITHEROE,  
Lancashire, BB7 1PE, United Kingdom

(72) Inventor(s)  
John Edward Lancaster

(74) Agent and/or Address for Service  
Roystons  
Tower Building, Water Street, LIVERPOOL, L3 1BA,  
United Kingdom

(51) INT CL<sup>5</sup>  
E04D 3/06 , E06B 3/68

(52) UK CL (Edition M )  
E1R RRH RR24

(56) Documents Cited  
GB 2259937 A GB 2246386 A GB 2111112 A  
EP 0293587 A2 EP 0244349 A2 WO 91/14056 A1  
WO 89/04408 A1

(58) Field of Search  
UK CL (Edition M ) E1R RRF RRH RRV  
INT CL<sup>5</sup> E04D 3/06 3/08 , E06B 3/54 3/64 3/68  
Online World Patents Index

(54) Roof glazing bar with upper and lower cappings

(57) A roof beam construction for use in constructing conservatory roofs comprises a glazing bar (10) and upper (12) and lower (14) cappings therefor having gaskets (30 and 40 respectively) formed integrally on edges thereof between which a roofing panel is to be retained and means (20 - 24, 32, 34) for locating the upper capping on the glazing bar, the lower capping being located by the gaskets (40).

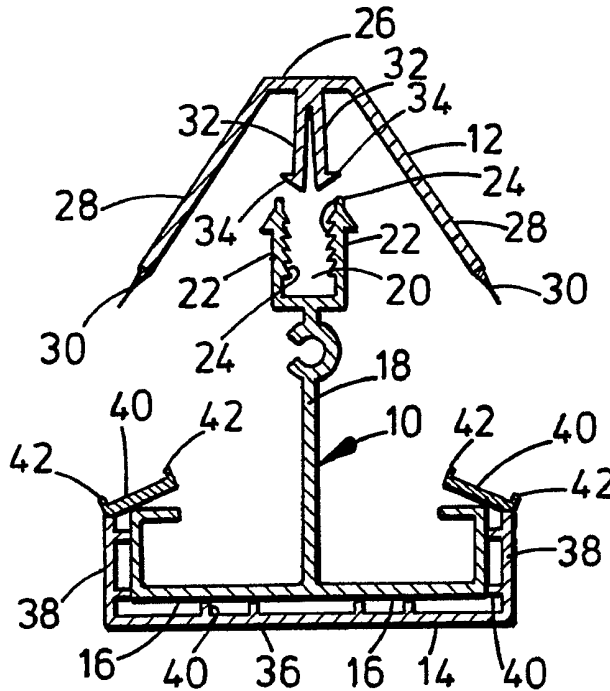

FIG. 1

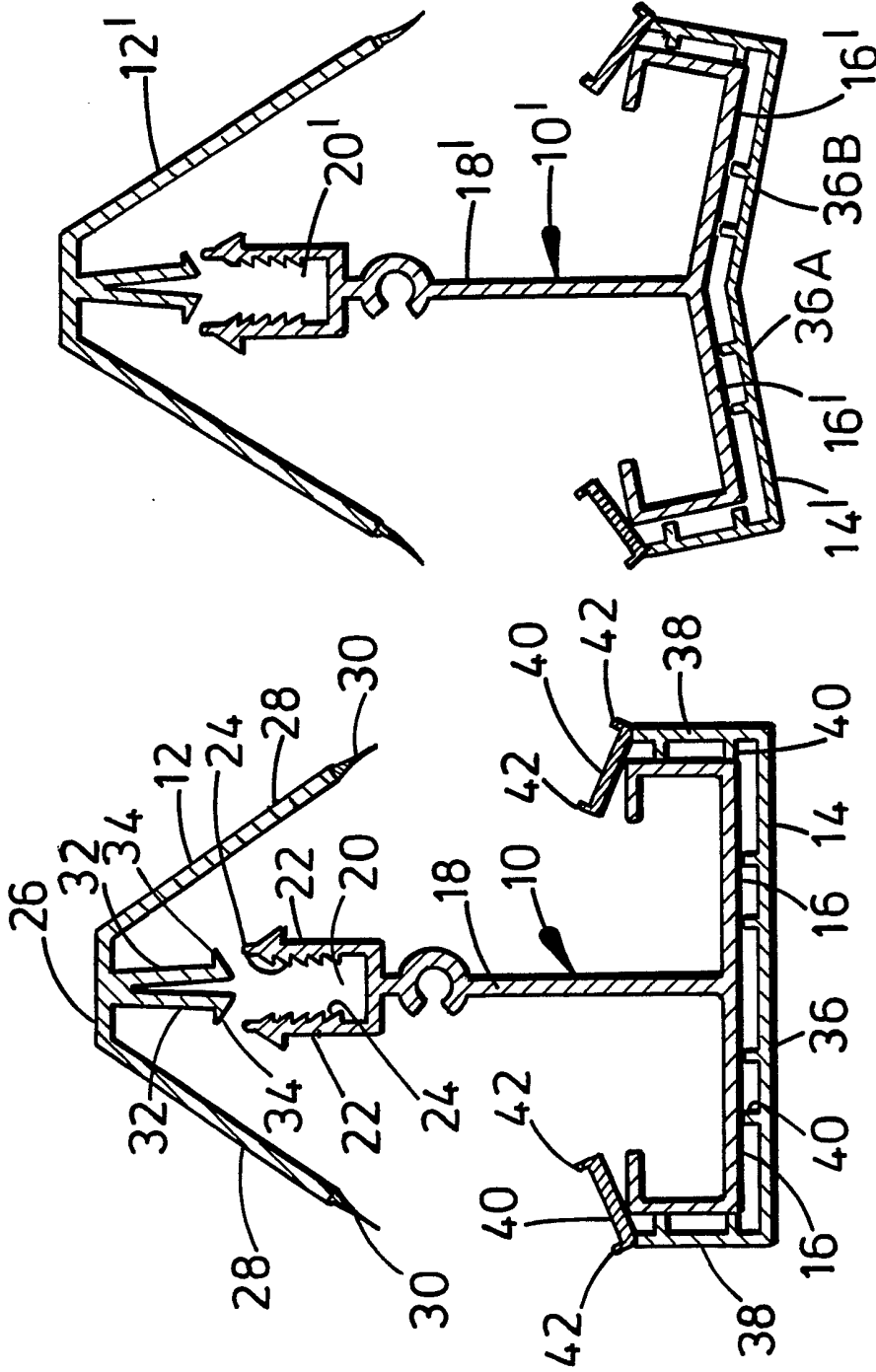

FIG. 1

FIG. 2

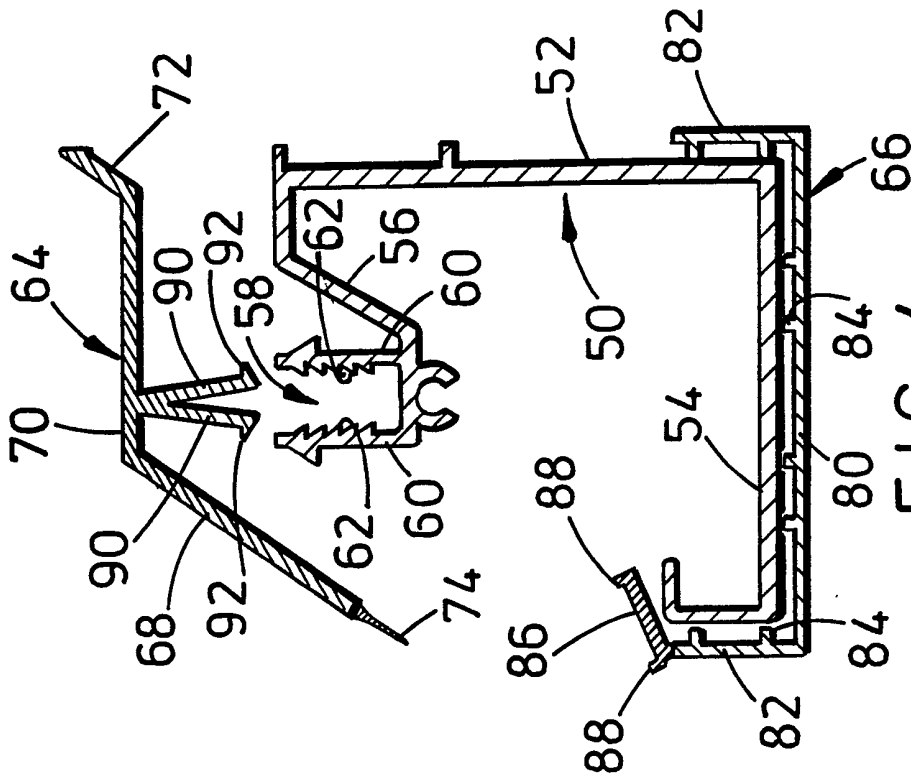

FIG. 4

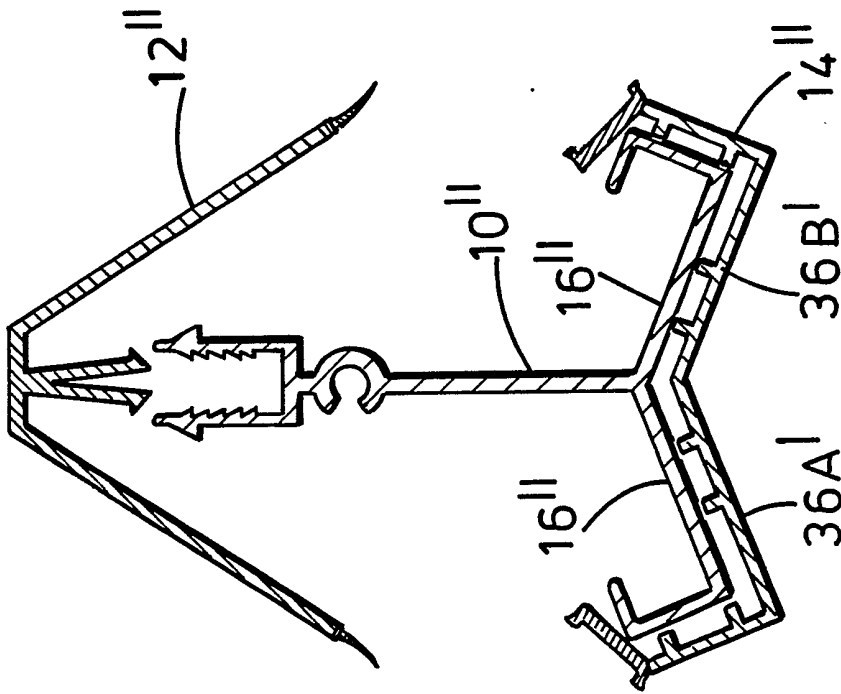

FIG. 3

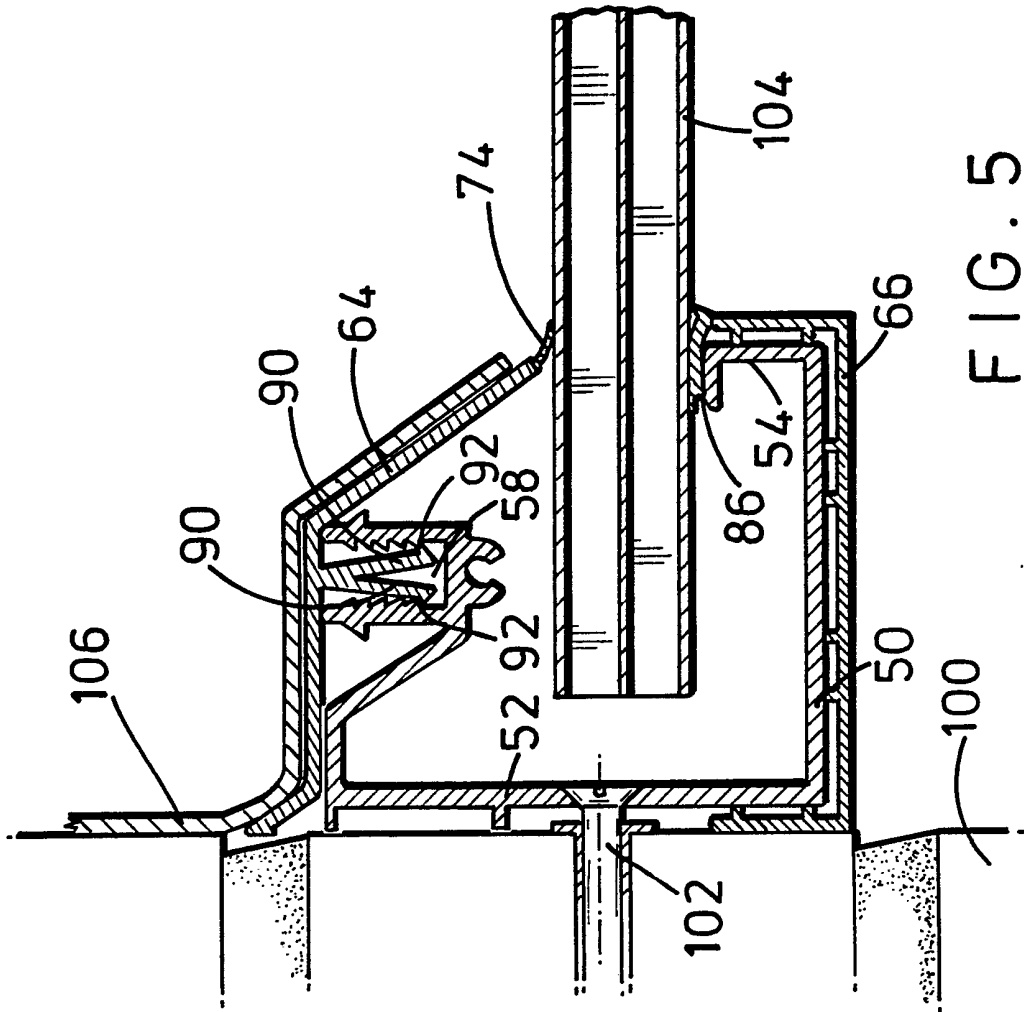

FIG. 5

Title: Roof Beams

DESCRIPTION

This invention concerns roof beams especially for use in constructing conservatories and like structures having roofs comprising panels usually of translucent material supported between roof beams.

Translucent panels for conservatory roofs are generally sandwiched at their edges between upper and lower roof beam forming extrusions coupled to a glazing bar, usually of aluminium. To provide a good seal above and below the translucent panels provisions are made for the roof beam to retain gaskets in suitable positions.

Upper beam forming extensions or cappings may have gaskets formed integrally with panel contacting edges thereof and gaskets for the underside of the panels are usually retained in special formations of the aluminium glazing bars. These gaskets have to be fitted to the extrusions on site which takes up time. Also, the extrusions are more expensive to produce because of the additional gasket retaining formations required.

Furthermore, in order to retain the lower beam forming extrusions, the aluminium glazing bar requires further formations on which the lower beam extrusion can locate.

An object of this invention is to simplify roof beams construction for use in, for example, constructing conservatories.

5 According to the present invention there is provided a roof beam construction for use in constructing conservatory roofs comprising a glazing bar and upper and lower cappings therefor having gaskets formed integrally on edges thereof between which a roofing panel is to be retained and means for locating  
10 said cappings on said glazing bar.

Preferably the means for locating the lower capping on the glazing bar comprises the integrally formed gaskets, which in use will be trapped between the glazing bar and a roofing panel.

15 A preferred lower capping is of extruded plastics material, such as PVC, and is preferably formed as a channel section with either a flat base or with a base having a pair of angled longitudinal facets.

The gasket material is preferably co-extruded  
20 onto the capping and is preferably of rubber or a synthetic elastomeric material. The gaskets preferably extend inwards from opposite sides of the channel and may have deformable resilient ribs or the like to provide a good seal when compressed. Internally of the  
25 lower cappings are preferably one or more spacer projections or ribs to ensure correct alignment of the

glazing bar and capping when fitted together.

The upper capping may be of any desired cross-section provided that it has at least one depending edge on which a gasket is formed. The preferred upper  
5 capping is formed by extrusion of plastics material, such as PVC and has gaskets co-extruded onto its depending edge or edges, again preferably of rubber or a synthetic elastomeric material. Internally of the upper capping there is preferably a means for coupling  
10 the capping to the glazing bar. Preferably resilient formations depend from the inside of the capping which formations have outward projections thereon and these formations locate in an upwardly open channel of the glazing bar which has a series of internal recesses or  
15 notches for receiving said projections. The provision of a series of recesses or notches for receiving the projections allows the resilient depending formations of the capping to be pressed down into the glazing bar any desired distance depending on the thickness of the  
20 roofing panel or panels which is or are being secured in place by the capping and make a snap fit.

A glazing bar which will have glazing panels on both sides preferably generally has a T-shaped cross-section which will be inverted in use. The upper limbs  
25 of the T may be flat or angled relative to each other depending on the shape of the base of the channel

section lower capping into which it is to fit. The, in use, upstanding limb of the glazing bar is preferably formed with said open channel for receiving locating formations of the capping.

5           The roof beam may be formed for locating a roofing panel on one side thereof, such as when the other side of the beam is to be secured to a wall or may be formed for locating roofing panels on opposite edges thereof for use intermediate edges of a roof  
10 structure.

This invention will now be further described, by way of example only, with reference to the accompanying drawings, in which:

Figure 1 shows a first roof beam arrangement  
15 according to the invention;

Figure 2 shows a second roof beam arrangement according to the invention;

Figure 3 shows a third roof beam arrangement according to the invention;

20           Figure 4 shows a fourth roof beam arrangement according to the invention; and

Figure 5 shows part of a conservatory roof incorporating the roof beam arrangement of Figure 4.

Referring to Figure 1 of the accompanying  
25 drawings, a roof beam arrangement for forming conservatory or like roofs comprises a reinforcing or



glazing bar 10, an upper capping 12 and a lower capping 14. In use roofing panels such as of translucent plastics material, for example polycarbonate will have their edges sandwiched between the upper  
5 capping 12 and the lower capping 14 on opposite sides of the roof beam arrangement.

The reinforcing beam 10 is extruded from aluminium and is generally of T-section but inverted in use. Thus, the reinforcing bar has a pair of flanges  
10 16, which are turned back on themselves at their remote ends, and an upstanding limb 18 which is bifurcated to form an upwardly open channel 20 having generally parallel sides 22. On the inside of each side 22 is a series of notches 24 forming downwardly open recesses.

15 The upper capping 12 is extruded from PVC and is generally of inverted V-section but comprising a flat top 16 and depending sides 28. The remote edges of the sides 28 have gaskets formed thereon by co-extrusion of rubber or synthetic elastomeric material. Internally of  
20 the capping and depending from its flat top 26 are a pair of resilient divergent flaps 32 having outwardly projecting lips 34 at their ends.

The lower capping 14 is also extruded from plastics material such as PVC and is generally formed as  
25 a channel section having a flat base 36 and upstanding side walls 38. Internally of the channel on the base

and on the side walls are spacing projections 40. The free edges of the side walls 38 have co-extruded thereon, from rubber or synthetic elastomeric material, gaskets 40 which extend inwardly and are inclined slightly upwards. The gaskets 40 include resilient deformable projections 42 on their upper surface.

In Figure 2, a roof beam arrangement is shown which is substantially the same as that of Figure 1 except that its channel section lower capping 14' has a pair of longitudinal facets 36A and 36B inclined relative to each other and flanges 16' of reinforcing bar 10' are correspondingly inclined relative to each other. Figure 3 is similar to Figure 2 except that the angle of inclination of the channel base facets 36A' and 36B' is greater, as is the angle of inclination of the reinforcing bars flanges 16''.

Figure 4 of the accompanying drawings shows a roof beam arrangement intended for fixing against a wall, so that a roofing panel is only held on one side thereof. This arrangement has a reinforcing or glazing bar 50 that has a main web 52 which will be fixed to the wall, a lower flange 54 extending perpendicularly from its lower end which flange is turned back on itself at its remote end remote from the main web and a formation 56 extending from its upper end, which formation includes an upwardly open channel 58 having generally

parallel sides 60. On the inside of each side wall 60 is a series of notches 62 providing generally downwardly open recesses.

The arrangement further comprises an upper capping 64 and a lower capping 66. The capping 64 is extruded from plastics material such as PVC and has a first web 68 enclosing an obtuse angle with a second web 70 which will be horizontal in use. Extending upwards from the second web is a shorter third web 72 generally parallel to the first web. The free edge of the first web 68 has a gasket 74 of rubber or synthetic elastomeric material co-extruded therealong. Depending from the second web 70 are a pair of resilient divergent flaps 90 having outwardly projecting lips 92 at their ends.

The lower capping 66 is also extruded from PVC and is of channel section having a flat base 80 and side walls 82. On the inside surfaces of the base and side walls are spacer projections or ribs 84. Co-extruded onto the top edge of one side wall 82 is a gasket 86 of rubber or synthetic elastomeric material. The gasket 86 is a generally flat strip inclined upwardly from the side wall and has at opposite sides resilient deformable ribs 88.

Each of the roof beam arrangements of Figures 1 of 4 of the accompanying drawings is used in the same

way. By way of example the roof beam arrangement of Figure 4 is shown in use in Figure 5 of the accompanying drawings. Firstly, the reinforcing bar 50 is secured to a wall 100 by means of screws 102 through main web 52 with the lower capping 66 held in place with one side wall between the reinforcing bar and the gasket of the other side wall over the returned end of the lower flange 54 of the reinforcing bar. A roofing panel 104 is then laid in place overlying the gasket 86 of the lower cover. The upper capping 64 is then fitted by parting its depending flaps 90 into the channel 58 of the reinforcing bar until the panel is held securely, the gasket strip 74 providing an upper water tight seal. The projecting lips 92 of the depending flaps 90 are retained in the notches on the inside surfaces of the channel 58 of the reinforcing bar. Flashing material 106 is added to provide a water-proof seal between the roof beam arrangement and the wall.

The roof beam arrangements of Figures 1 to 3 are used in a similar manner to that of Figure 4, except that the reinforcing bar is fixed between lateral beams of the roof under construction such as a ridge beam and an eave and roofing panels are laid on opposite sides of the reinforcing bar on top of the gaskets of the lower capping. Then the upper capping is pressed into place onto the reinforcing bar to hold the roofing panels in

place, the gaskets of the upper and lower cappings providing good seals above and below the roofing panels.

By providing sealing gaskets on the capping and  
5 the lower cover instead of separately therefrom, the number of procedural steps for constructing a roof are reduced, so that construction can be simpler and quicker than hitherto.

## CLAIMS

1. A roof beam construction for use in constructing conservatory roofs comprising a glazing bar and upper and lower cappings therefor having gaskets formed integrally on edges thereof between which a roofing panel is to be retained and means for locating the cappings on said glazing bar.  
5
2. A roof beam construction as claimed in claim 1, wherein the means for locating the lower capping on the glazing bar comprises the integrally formed gaskets, which in use are trapped between the glazing bar and roofing panel.  
10
3. A roof beam construction as claimed in claim 1 or 2, wherein the lower capping is of extruded plastics material.  
15
4. A roof beam construction as claimed in claim 1, 2 or 3, wherein the lower capping is formed as a channel section with a flat base or with a base having a pair of angled longitudinal facets.
5. A roof beam construction as claimed in claim 4, wherein the gaskets of the lower capping extend inwards from opposite sides of the channel.  
20
6. A roof beam construction as claimed in claim 5, wherein the gaskets have deformable resilient ribs.
7. A roof beam construction as claimed in claim 5 or  
25

6, wherein the lower capping has internally of its channel section one or more spacer projections or ribs.

8. A roof beam construction as claimed in any one of claims 1 to 7, wherein the upper capping is extruded from plantics material.

10. A roof beam construction as claimed in any one of claims 1 to 9, wherein the upper capping has internally thereof means for coupling the capping to the glazing bar.

11. A roof beam construction as claimed in claim 10, wherein resilient formations depend from inside of the capping which formations have outward projections thereon for location in an upwardly open channel of the glazing bar, which channel has a series of internal recesses or notches for receiving the projections of the capping.

12. A roof beam construction as claimed in any one of claims 1 to 11, wherein the glazing bar has a generally T-shaped cross-section, inverted in use.

13. A roof beam construction as claimed in claim 12, wherein the upper limbs of the T-section are flat or angled relative to each other.

14. A roof beam construction as claimed in claim 12 or 13 with claim 11, wherein the, in use, upstanding limb of the glazing bar is formed with said open channel for receiving locating formations of the capping.

15. A roof beam construction substantially as hereinbefore described with reference to and as illustrated in any one of the accompanying drawings.



**Relevant Technical Fields**

- (i) UK Cl (Ed.M) E1R: RRF, RRH, RRV  
 (ii) Int Cl (Ed.5) E04D: 3/06, 3/08; E06B 3/54, 3/64, 3/68

**Databases (see below)**

- (i) UK Patent Office collections of GB, EP, WO and US patent specifications.  
 (ii) ONLINE WORLD PATENTS INDEX

Search Examiner  
 JOHN ROWLATT

Date of completion of Search  
 23 MAY 1994

Documents considered relevant following a search in respect of Claims :-  
 1-15

**Categories of documents**

- X:** Document indicating lack of novelty or of inventive step.      **P:** Document published on or after the declared priority date but before the filing date of the present application.  
**Y:** Document indicating lack of inventive step if combined with one or more other documents of the same category.      **E:** Patent document published on or after, but with priority date earlier than, the filing date of the present application.  
**A:** Document indicating technological background and/or state of the art.      **&:** Member of the same patent family; corresponding document.

Category	Identity of document and relevant passages	Relevant to claim(s)
Y	GB 2259937 A (SCHOLES)	1, 3, 4, 8, 10-14
Y	GB 2246386 A (ARIEL PLASTICS LIMITED)	1, 3, 4, 8, 10-14
Y	GB 2111112 A (MARLEY TRIDENT LIMITED)	1, 3, 4, 8, 10-14
Y	EP 0293587 A2 (JOH GRAUTE GMBH & CO)	1, 3, 4, 8, 10-14
X,Y	EP 0244349 A2 (DÄTWYLER)	X: 1, 3, 4, 5 AND 8-11 Y: 12 AND 13
Y	WO 91/14056 A1 (STROBEL)	1, 3, 4, 8, 10-14
X,Y	WO 89/04408 A1 (DATWYLER)	X: 1, 3, 4, 5 AND 8-11 Y: 12 AND 13

**Databases:**The UK Patent Office database comprises classified collections of GB, EP, WO and US patent specifications as outlined periodically in the Official Journal (Patents). The on-line databases considered for search are also listed periodically in the Official Journal (Patents).