

E. TUCKER.
Folding-Chair.

No. 211,196.

Patented Jan. 7, 1879.

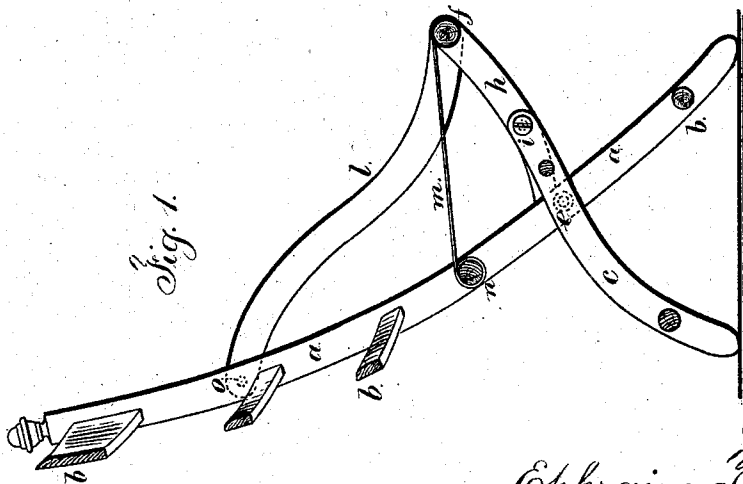
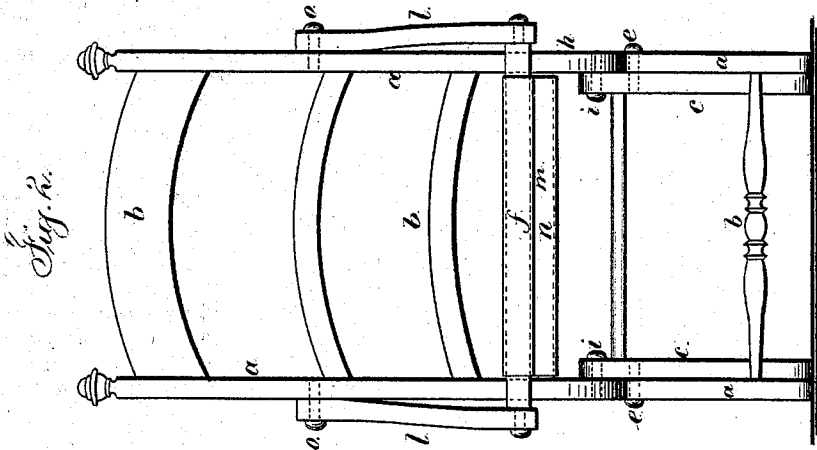
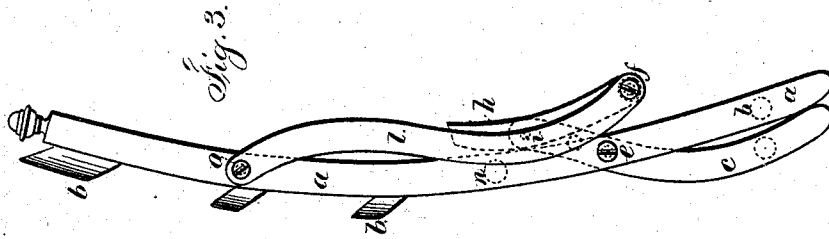

Witness
Chas H Smith
Geo. T. Pinckney

Inventor
Ephraim Tucker.
per Lemuel W. Serrell, atty.

UNITED STATES PATENT OFFICE

EPHRAIM TUCKER, OF WORCESTER, MASSACHUSETTS, ASSIGNOR TO
EDWARD W. VAILL, OF SAME PLACE.

IMPROVEMENT IN FOLDING CHAIRS.

Specification forming part of Letters Patent No. **211,196**, dated January 7, 1879; application filed
March 15, 1878.

To all whom it may concern:

Be it known that I, EPHRAIM TUCKER, of Worcester, in the State of Massachusetts, have invented an Improvement in Folding Chairs, of which the following is a specification:

Folding chairs have been made in which the back legs have been in two parts, hinged with knuckle-joints, that serve to limit the movement in one direction, but they were not adapted to flexible seats, because there was nothing to keep the parts under strain, and hence the legs might close or fold when the chair is being moved from place to place.

My present invention consists in the combination, with the back and folding legs, of a seat-frame connected to the front parts of the back legs by pivots, and having stops to limit the motion and arm-pieces extending to the back, whereby the seat is strained and the parts rendered rigid when in use, but capable of being folded. This improvement is especially adapted to flexible seats, but may be used with rigid seats.

In the drawing, Figure 1 is a section of the chair as unfolded for use. Fig. 2 is a front elevation, and Fig. 3 is a side view, of the chair as folded.

The back and front legs are formed as one frame, composed of the side pieces, *a a*, and cross pieces or rails *b b*, and these may be ornamental or plain, and cane or upholstery may be used in the back. The back legs, *c*, are pivoted to the front legs at *e*, and the seat-frame is composed of the rails *f* and side pieces *h*. These latter are pivoted at *i* to the forward upper portion of the back legs, *c*, and from the ends of the rail *f* the arm-pieces *l* extend to the back, and are pivoted to the same at *o*. The seat *m* is between the rails *f* and *n*, and when flexible is stretched between them, but if rigid it may rest upon them or be pivoted to the back-frame *a*, and rest upon *f*.

It will now be apparent that when the chair is folded the arm-pieces *l* swing upon the pivots *o* and fold toward the back-frame. The seat-frame and upper portions of the back legs

form toggles, that fold as the cross-legs swing into line with each other, or nearly so. The reverse movement, as the chair is unfolded for use, strains the seat, because the toggle-action of *h* and *c*, swinging on the pivots *i*, forces the rail *f* away from the rail *n*, and if the joint *i* passes beyond its point of greatest strain before its movement is stopped the chair cannot be folded without again increasing the tension on the seat; hence the chair stands very firmly, and is not liable to fold in moving it from place to place.

In order to limit the movement of the toggle formed by *h* and *c*, I make the ends of the side pieces *h* long enough to come into contact with the legs *a a*, or the upper ends of the back legs *c* may be prolonged sufficiently to stop against the rail *f*, or any other suitable stop may be provided.

I am aware that a rocking-chair has been made with the front legs and back in one frame, and with the back legs and seat-frame pivoted together. In this case, however, it was necessary to provide a movable pivotal connection between the front and back legs. In my device the cross-legs are united together by fixed pivots, which render the chair firm and prevent the risk of the same folding accidentally.

I claim as my invention—

In a folding chair, the seat-frame *h*, attached by pivots *i* to the upper ends of the back legs, *c*, and provided with stops between the front legs, *a*, and rail *f* to render the seat-frame and back legs rigid and limit the motion when the chair is unfolded for use, in combination with the arm-pieces *l*, the back and front legs formed as one frame, and the pivots *e*, that connect the front and back legs at their crossing, but allow them to fold, substantially as set forth.

Signed by me this 9th day of March, A. D. 1878.

EPHRAIM TUCKER.

Witnesses:

S. B. I. GODDARD,
GEO. E. SMITH,