

No. 638.906.

Patented Dec. 12, 1899.

J. CONNELL.
MACHINE FOR PRINTING ON BOARDS.

(Application filed May 11, 1898.)

(No Model.)

5 Sheets—Sheet I.

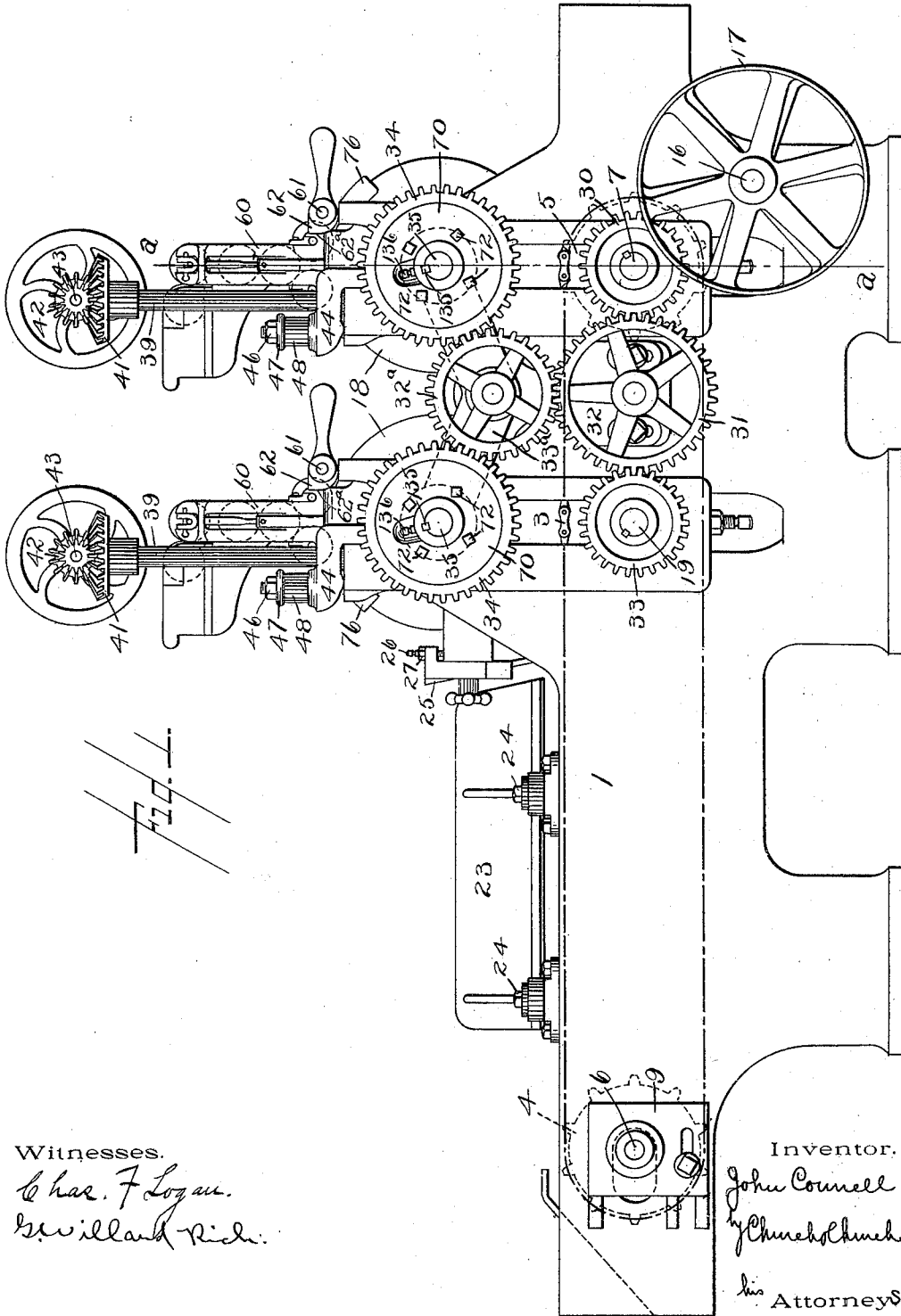

Witnesses.

Chas. F. Logan.
S. Willard Rich.

Inventor.

John Connell
by Church & Knudsen

his Attorneys

No. 638,906.

Patented Dec. 12, 1899.

J. CONNELL.

MACHINE FOR PRINTING ON BOARDS.

(Application filed May 11, 1898.)

(No Model.)

5 Sheets—Sheet 2.

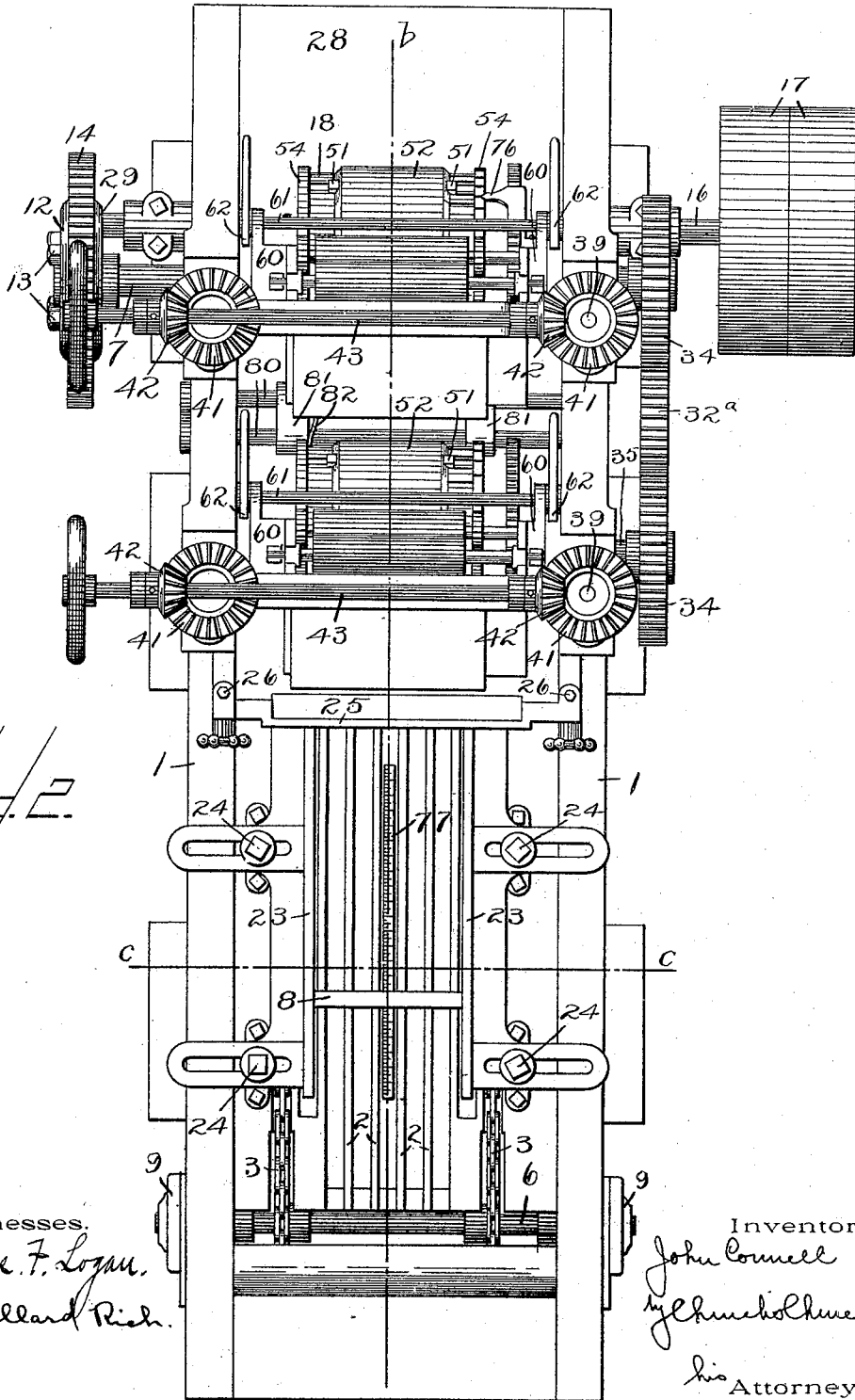

Witnesses.
Chas. F. Logan.
Willard Rich.

Inventor.
John Connell
John H. Holmsted
 his Attorney

No. 638,906.

Patented Dec. 12, 1899.

J. CONNELL.

MACHINE FOR PRINTING ON BOARDS.

(Application filed May 11, 1898.)

(No Model.)

5 Sheets—Sheet 3.

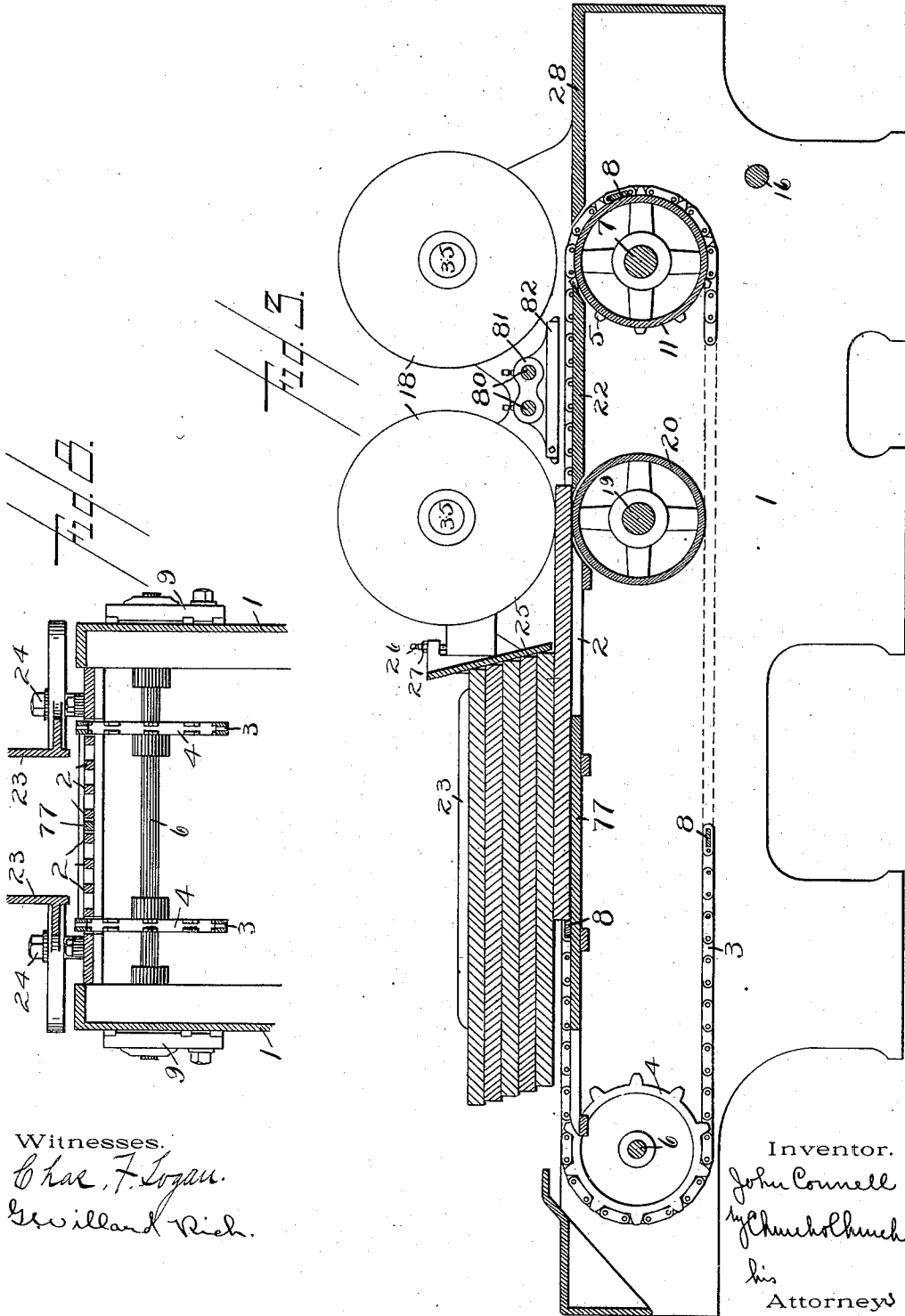

Witnesses.

Char. F. Logan.
Gwilland Rich.

Inventor.

John Connell
by Church & Church
his
Attorneys

J. CONNELL.

MACHINE FOR PRINTING ON BOARDS.

(Application filed May 11, 1898.)

(No Model.)

5 Sheets—Sheet 4.

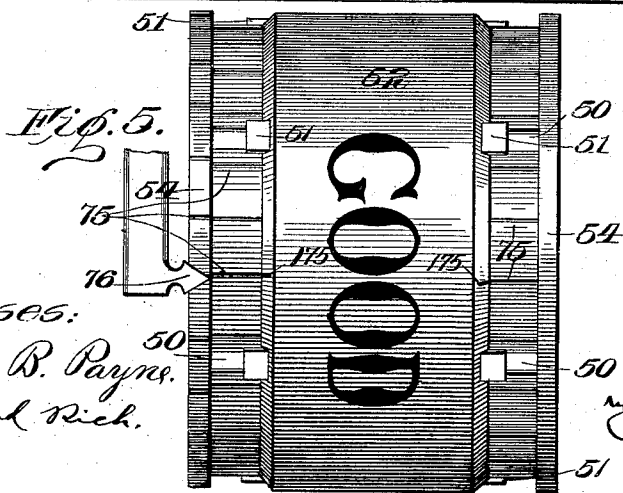
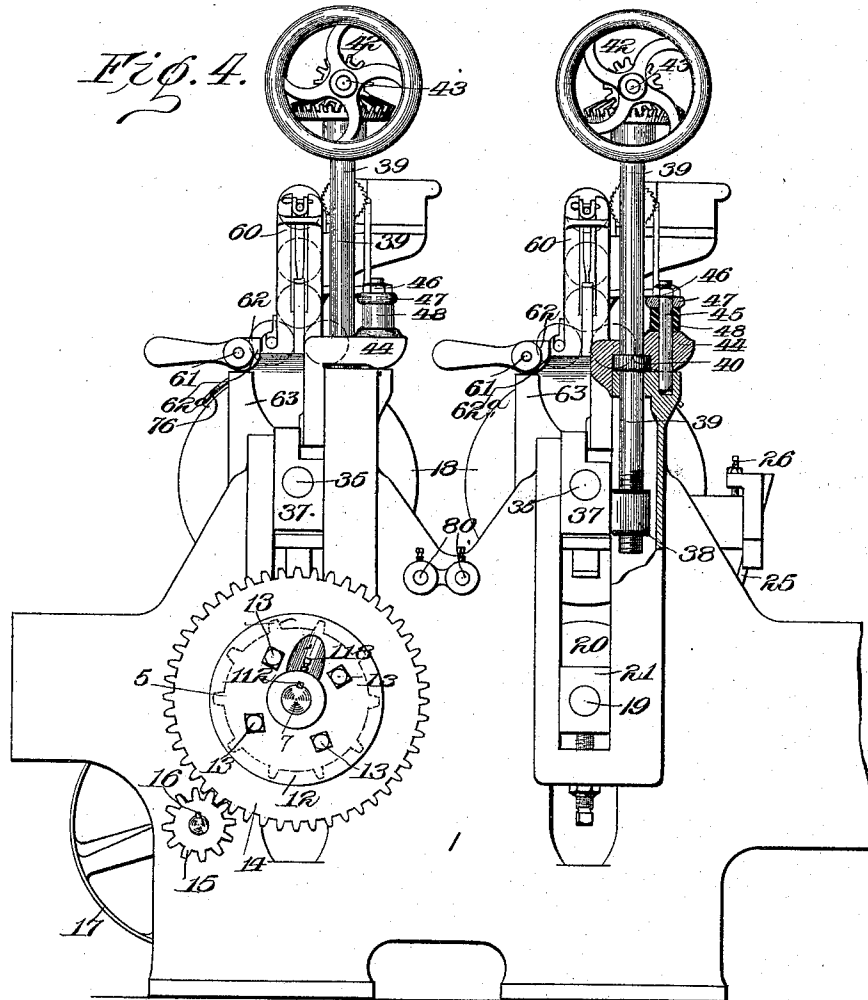

Witnesses:
 Walter B. Payne.
 Willard Rich.

Inventor,
 John Connell
 by Church & Church
 his
 Attorneys.

No. 638,906.

Patented Dec. 12, 1899.

J. CONNELL.

MACHINE FOR PRINTING ON BOARDS.

(Application filed May 11, 1898.)

(No Model.)

5 Sheets—Sheet 5.

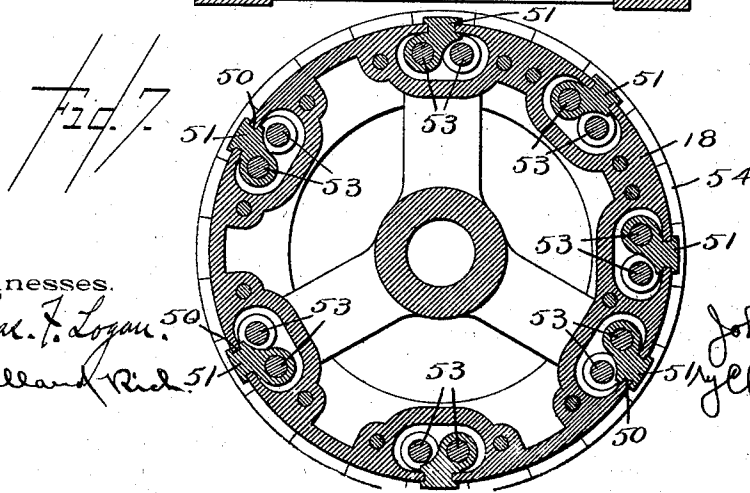
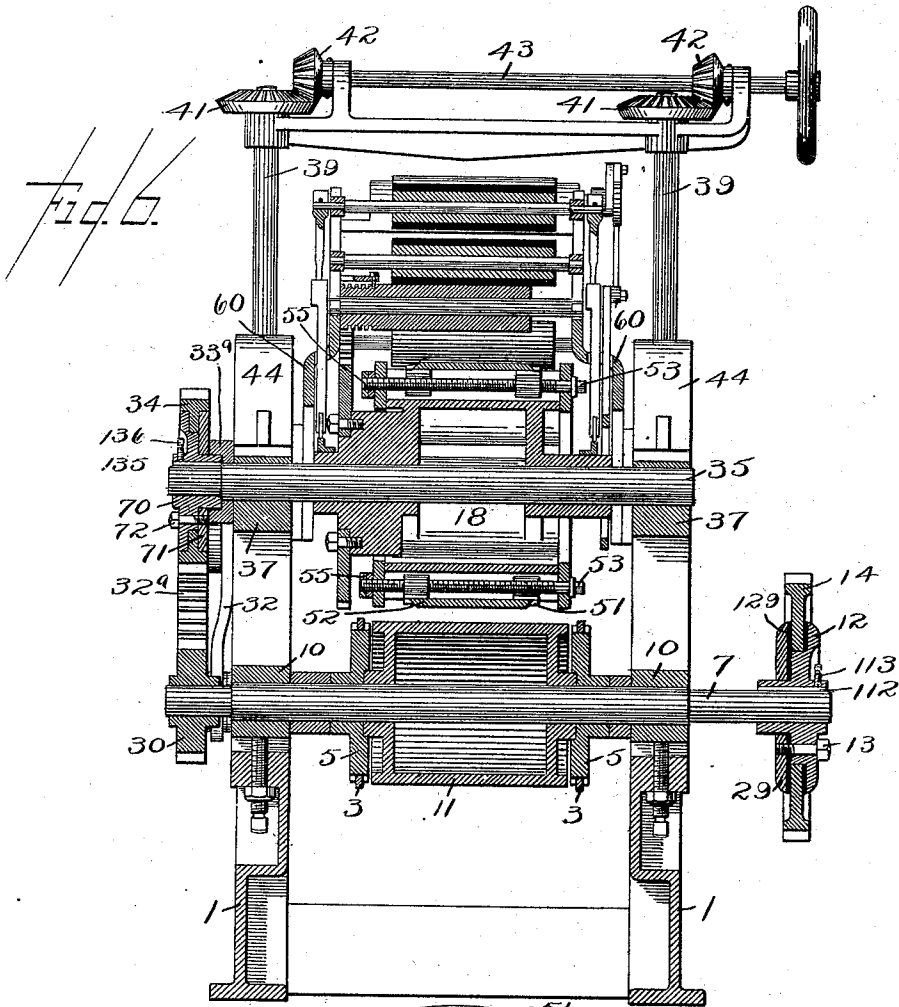

Witnesses.

Char. F. Logan.
William Reid.

Inventor.

John Connell
his Attorney

UNITED STATES PATENT OFFICE.

JOHN CONNELL, OF ROCHESTER, NEW YORK.

MACHINE FOR PRINTING ON BOARDS.

SPECIFICATION forming part of Letters Patent No. 638,906, dated December 12, 1899.

Application filed May 11, 1898. Serial No. 680,393. (No model.)

To all whom it may concern:

Be it known that I, JOHN CONNELL, of Rochester, in the county of Monroe and State of New York, have invented certain new and useful Improvements in Machines for Printing on Boards, &c.; and I do hereby declare the following to be a full, clear, and exact description of the same, reference being had to the accompanying drawings, forming a part of this specification, and to the reference-numerals marked thereon.

My present invention relates to machines for printing upon boards, particularly those used for making boxes, and has for its objects to improve the construction and operation of the devices for causing the proper register of the feeding devices and printing-forms, the adjustment of the printing form or cylinder, and the operating devices of the machine; and to these and other ends the invention consists in certain improvements hereinafter fully described, the novel features being pointed out particularly in the claims at the end of this specification.

In the drawings, Figure 1 is a side elevation of a machine constructed in accordance with my invention; Fig. 2, a plan view of the same; Fig. 3, a longitudinal-sectional view showing the printing-cylinders only diagrammatically; Fig. 4, an elevation of a portion of the side of the machine opposite that shown in Fig. 1; Fig. 5, a detail of the printing-cylinder and the form thereon; Fig. 6, a vertical sectional view on the line *aa* of Fig. 1; Fig. 7, an enlarged cross-sectional view of the printing cylinder or form; Fig. 8, a sectional view on the line *cc* of Fig. 2.

Similar reference-numerals indicate similar parts.

The main frame of the machine embodies the two side pieces or frames 1 1, connected by suitable cross pieces or braces and having a supporting-table for the boards to be printed upon, composed, preferably, of bars 2.

3 3 indicate sprocket-chains passing around sprockets 4 4 and 5 5, arranged on shafts 6 and 7, located at opposite ends of the machine, said chains being connected at suitable intervals by feeding strips or bars 8. The rear shaft 6 is mounted in bearings 9, adjustable longitudinally of the side frames, at the rear or feed end thereof, and the shaft 7

is arranged in bearings 10, vertically adjustable on the main frame, and carries a smooth presser-roller 11. To one end of the shaft 7 is secured (by a key 112 and set-screw 113) a friction-disk 12, having an annular plate 29, secured to it by bolts 13, adapted to clamp between them the web of a large gear 14, which latter, except for the frictional connection with the gear 14, is loose on the shaft and meshes with a pinion 15 on the end of the driving-shaft 16, to which the power for operating the machine is applied through pulleys 17. The friction between the gear and shaft is sufficient to cause the proper driving of the machine under ordinary circumstances; but should a board or knot become caught in the operating parts and the operation arrested the parts will not become broken, as the driving-shaft will be allowed to slip, while the operating parts remain stationary. Instead of having a direct metal contact between the gear and disks I prefer to interpose a somewhat yielding material, as leather 129. (Shown particularly in Fig. 5.)

As the present machine is adapted for printing in two colors upon the boards, or at least of making two separate imprints thereon, there are necessarily two printing or form cylinders 18, one arranged directly over and cooperating with the roller 11 and the other located directly over a roller 20 on a shaft 19, journaled in bearings 21 in the side frames and having its surface alined with that of the bed or support and of the roller 11, and said bed or support is extended between the rollers 11 and 20, as at 22.

80 indicates transverse rods extending between the side frames and having side guides 81 thereon, one of the latter having the yielding or spring guide 82, as shown in Figs. 2 and 3.

It will be understood that if it is desired to print in only one color or to make a single impression the roller 20 and the section 22 of the bed could be dispensed with.

The boards to be printed upon are piled upon the bed 2 between side guides or plates 23, adjustably secured to the side frames of the machine by bolts 24 or otherwise, and in front of said guides, in the direction of movement of the chains, is arranged an inclined guard-plate 25, adjustable upon the side

frames in any suitable manner, as by screws 26, engaging the side frames and secured by screws or nuts 27, the distance between the bottom of plate 25 and the bed being approximately the thickness of the boards to be operated upon. As the bars 8 on the chains or conveyers pass beneath the box or receptacle formed by the plates 23 and 25 the bottom board of the pile will be fed over the bed between the rollers 11 and 20 and their cooperating printing or form rollers and subjected to the action of the latter and then will be carried out by the chain carriers and deposited upon the table 28. Upon one end of the shaft 7 is a gear 30, meshing with a gear 31, mounted on an adjustable frame or support 32 on the side frame, and said gear 31 meshes with a gear 33 on the shaft 19 of the roller 20, so that both the shafts 11 and 20 will be driven at the same speed and in the same direction.

As the printing-cylinders and the adjusting and inking devices for each are the same, a description of one will apply to both, said rollers, however, being both driven from a gear 32^a, loose on an adjustable frame or hanger 33^a, meshing with the adjustable gear 31 on the main frame and also meshing with gears 34, adjustably secured to the shafts 35 of the printing-cylinders, as will be described. The frame or hanger 33^a loosely encircles the shafts of and moves with the upper or form rolls, and either or both of the latter may be adjusted vertically without disconnecting the driving mechanism.

The shaft 35 of the form-cylinder 18 is mounted in bearings 37, vertically movable in suitable vertical ways formed in the side frames, said bearings having lateral threaded lugs 38, in which enter the threaded ends of the vertical adjusting screw-shafts 39, having the collars 40 thereon normally resting upon the tops of the side frames 1 and having gears 41 at their upper ends meshing with gears 42 on a transverse adjusting-shaft 43, by the manipulation of which latter the opposite ends of the shaft can be simultaneously adjusted, or, if desired, any other suitable means could be employed for causing this adjustment.

44 indicates cap-plates on the side frames 1, through which the shafts 39 pass and with the under side of which the collars 40 are in engagement, said plates having apertures for the passage of bolts 45, rigidly attached to the main frame and provided with nuts 46 and washers 47, engaging the top of tension-springs 48 (preferably of rubber) on the plates 44, as shown. From this construction it will be seen that the cylinder is supported from the main frame by the collars 40 and may be adjusted relative its cooperating roller; but if a board thicker than normal passes between them the springs will yield and permit their separation the necessary distance, and said springs will also insure sufficient pressure to cause the proper impression to be made on the boards.

The cylinder or drum 18 is rigidly secured to its shaft and is provided with a series of longitudinal slots 50 in its periphery for the passage of the adjustable clamping-dogs 51, adapted to engage the edges of the printing form or plate 52 and hold it in position, said dogs being provided with the laterally-extended lugs or offset portions threaded for the passage of the adjusting-screws 53, passing through them and also through heads 54, secured to the ends of the drum or roller, as in Figs. 6 and 7. The screws turn freely in the heads 54, and one end of each is angular for the application of a wrench and the other is provided with locking-nuts 55, and the object in forming the offsets on the dogs is to permit one pair to be slipped into each slot in the drum with the offset portions reversed, and the two screws being close together the dogs may be operated in opposite directions from one end of the drum to clamp the printing-form 52 firmly on opposite sides.

The inking devices for the printing-forms may be of any suitable construction; but I prefer to mount the fountain and all of the inking-rollers upon a vertically-adjustable frame embodying the side pieces 60, having the forward extensions, in which is journaled a shaft 61, having cams 62 thereon, resting upon projections 63 in the main frame, said cams having the flat sides 62^a, so that by turning said cam-shaft the inking devices may be moved out of contact with the printing-form when desired and held by the flat sides 62^a of the cams resting on the projections 63.

The adjustable connection between the shaft 35 of the printing-cylinder and its operating-gear 34 may be of any suitable construction, so as to permit of the adjustment of the forms independently of the driving mechanism; but I prefer to secure to the shaft 35 by the key 135 and set-screw 136 the wheel 70, having the disk 71 connected thereto by bolts 72, said wheel and disk receiving between them the web of the gear 34, (see Fig. 6,) so that by loosening the bolts the form-roller may be turned independently of the gear, and when the parts are clamped together the roller will be positively operated by the gear, which is constantly in mesh with the driving mechanism.

For the purpose of adjusting the printing form or forms relative to the boards operated upon so that the imprint will occupy the proper position thereon and also to cause the proper register of the colors or imprints, if both printing devices are employed, I provide upon the printing-cylinders a scale formed of a series of longitudinal marks or grooves (see Fig. 5) and arrange upon the frame of the inking device an index-finger 76, adapted to cooperate with said scale. I also preferably provide upon the sides of the printing form or plate marks 175, indicating the center of the plate or the design or word thereon, which when the plate is clamped on the cylinder is brought into register with the cen-

tral mark or line 75 on the latter, this serving to cause the proper correlation of the parts. In the bed-plate of the machine, and preferably within the receptacle for the boards, I locate a scale 77, corresponding in marking, and preferably in length, with the scale on the cylinder or cylinders, the divisions of the scales being in inches and fractions thereof, if desired. The index coöperating with the scale 77 is preferably the feeding-bars 8 on the conveying-chains, as these cause the positive movement of the boards, and their position corresponds exactly with that of the end of the board. In adjusting the impression or impressions the operator moves the driving mechanism by hand or otherwise until one of the bars 8 on the carrier registers with any desired portion of the scale 77 on the bed—as, for instance, if he desires the center of the word or figure on the printing-form to be printed at the center of a board twenty-four inches long (the scale being in inches) he will bring the bar 8 with its forward edge on the twelfth mark. He then disconnects the cylinder from its operating-gear 34 and turns it until the line of the scale on the cylinder-surface corresponding to the center of the word or form is in line with the index 76 and clamps the gear 34 to the cylinder by two bolts 72, and the machine is ready for operation. If both printing-cylinders are in use, they may be each registered in the same manner, the one first adjusted being clamped before the feeding devices are moved, as will be understood.

The index 76 is stationary with relation to the rotary motion of the printing-cylinder and may therefore be said to be connected to the main frame, and, in fact, it could be located there if the boards operated upon were of uniform thickness; but as they vary and the cylinder is required to be vertically adjustable the best location is upon the frame of the inking mechanism, as this is adjusted vertically with the cylinder and always bears the same relation to it when the inking devices are being used.

I prefer to employ the marks 75 extending lengthwise of the cylinder, as shown, so that the adjustment may be readily accomplished, as the operator will be enabled to accurately position the mark to the index, or the index could, if desired, register with the printing form or plate or with marks formed thereon. However, the lines on the cylinder may be used with any form, and a straight-edge laid across the form in line with the marks will insure an accurate adjustment.

After the machine is adjusted the boards may be placed in a pile upon the support, and they will be fed through singly and printed in one or more colors or designs, the several impressions properly registering.

I claim as my invention—

1. In a machine for printing on boards, the combination with the main frame, the scale

thereon, and the movable board-feeding bar coöperating with the scale, of the printing-cylinder, and indicia for indicating its adjustment relative to the main frame, and adjustable operating mechanism between said feeding-bar and the cylinder.

2. In a machine for printing on boards, the combination with the main frame, the bed or support, conveying devices embodying projections for separately engaging the boards to be operated upon, and indicia between said engaging projections and the main frame, of a printing or form cylinder, operating devices for the latter adjustably connected with the conveying devices, and indicia between the cylinder and the stationary frame for indicating the position of the former relative to the latter.

3. In a machine for printing on boards, the combination with the main frame, the scale thereon, the endless conveyer having the cross-bars arranged to feed boards singly and coöperating with the scale and operating devices for the conveyer, of the printing form or cylinder, the gear connected with the conveying devices, adjustable connections between said gear and the cylinder, and indicia between the cylinder and frame for indicating their relative position.

4. In a printing-machine, the combination with the main frame, the cylinder mounted thereon, and the coöperating printing-cylinder, of the bearings 37 sliding on the main frame, the adjusting-screws 39 having the collars 40 resting on the main frame, said screws engaging the bearings 37 beneath the collars, the cap-plates 44 extending over the collars 40, the bolts 48 engaging the frame and the springs 45 interposed between the heads of said bolts and the cap-plates, 44, substantially as described.

5. The combination with the main frame, the roller thereon, and the printing-cylinder coöperating therewith, of the bearings for said printing-cylinder, the adjusting-screws having the collars supported on the main frame, the cap-plates engaging the outer sides of the collars, and the springs operating on the cap-plates.

6. The combination with the main frame, the rollers journaled thereon, and the gears 30 and 33 and the gear 31 meshing with them and adjustably supported on the frame, of the adjustable printing-cylinders having the gears 34, the yoke or hanger 33^a and the gear 32^a meshing with the gear 31 and gears 34, substantially as described.

7. In a printing-machine, the combination with the main frame, the scale on the bed, and board-conveying devices arranged to cooperate with the scale, of a vertically-adjustable printing-cylinder, an adjustable driving connection between it and the board-feeding devices, the supplemental frame vertically adjustable with the cylinder, and indicia between the supplemental frame and cylinder

for indicating the relative rotary adjustment of the latter.

8. In a printing-machine, the combination with the main frame, a printing-cylinder having form-clamps thereon and also a scale, of a printing-form adapted to be held by the clamps and having an index or mark adapted

to register with those on the cylinder and a stationary index cooperating with the scale on the cylinder.

JOHN CONNELL.

Witnesses:

F. F. CHURCH,
GRACE A. RODA.