

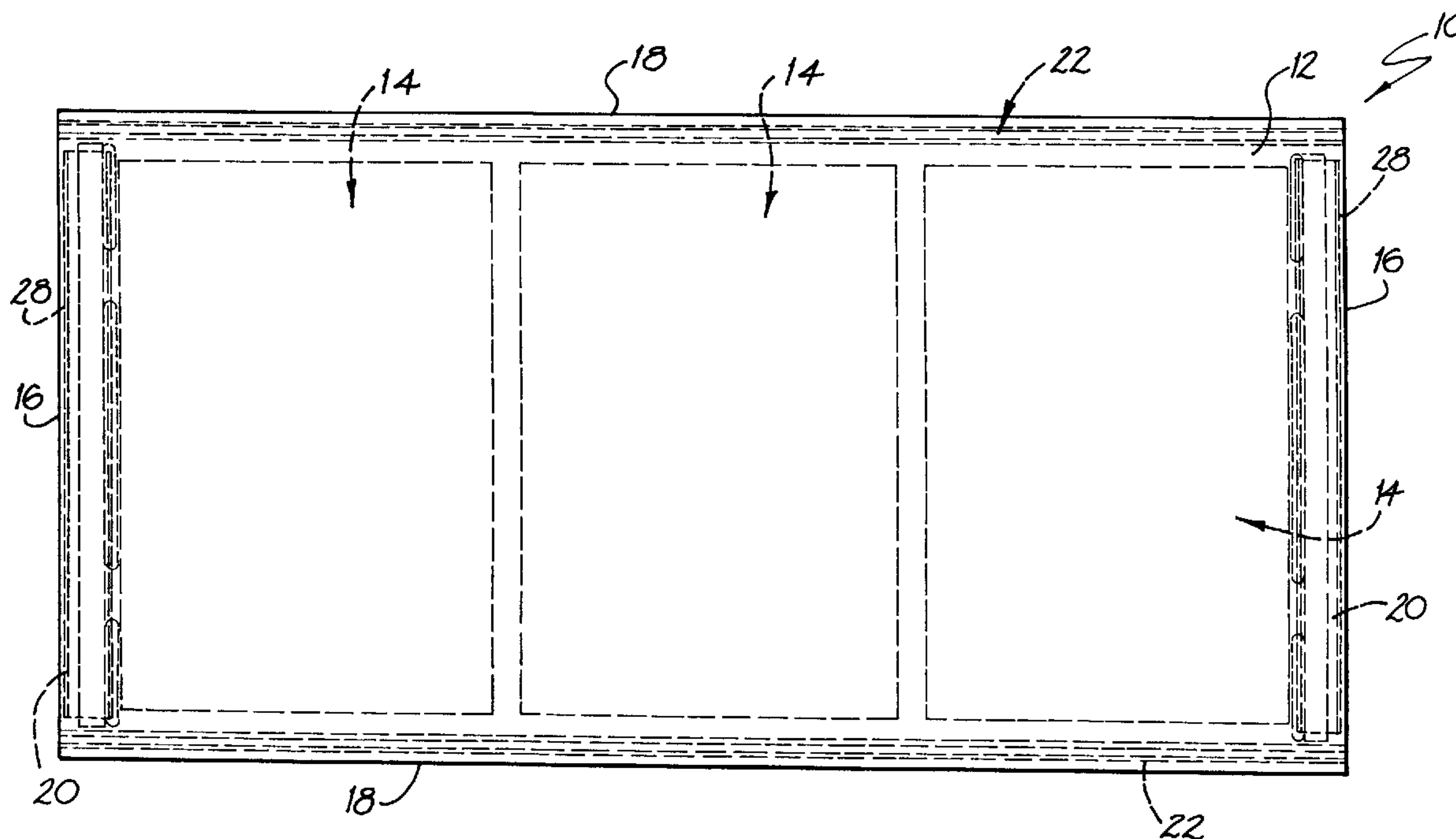

(86) Date de dépôt PCT/PCT Filing Date: 2000/12/06
 (87) Date publication PCT/PCT Publication Date: 2001/06/14
 (85) Entrée phase nationale/National Entry: 2002/05/22
 (86) N° demande PCT/PCT Application No.: AU 2000/001500
 (87) N° publication PCT/PCT Publication No.: 2001/041944
 (30) Priorité/Priority: 1999/12/09 (PQ 4558) AU

(51) Cl.Int.⁷/Int.Cl.⁷ B07B 1/46
 (71) Demandeur/Applicant:
 USF JOHNSON SCREENS PTY LTD., AU
 (72) Inventeurs/Inventors:
 EELES, JOHN WILLIAM, AU;
 OLSEN, PETER MARTIN, AU
 (74) Agent: BROUILLETTE KOSIE

(54) Titre : **MODULE TAMIS ET ENSEMBLE TAMIS COMPRENANT UN TEL MODULE**
 (54) Title: **A SCREENING MODULE AND A SCREENING ASSEMBLY INCLUDING SUCH MODULE**



(57) **Abrégé/Abstract:**

A screening module for a screening assembly includes a substantially rectangular, planar screening member having a plurality of screening apertures extending through it the member having a pair of sides extending parallel to a direction of flow of material over the member and a pair of sides extending transverse to a direction of flow of material over the member. A mounting means is formed integrally with the screening member as a one-piece unit for securing the member to an underlying structure. A part of the mounting means is arranged along each side of the screening member and only the parts of the mounting means associated with one pair of sides having reinforcing with the parts of the mounting means associated with the other pair of sides being without reinforcing.

(12) INTERNATIONAL APPLICATION PUBLISHED UNDER THE PATENT COOPERATION TREATY (PCT)

(19) World Intellectual Property Organization
International Bureau(43) International Publication Date
14 June 2001 (14.06.2001)

PCT

(10) International Publication Number
WO 01/41944 A1

- (51) International Patent Classification⁷: B07B 1/46
- (21) International Application Number: PCT/AU00/01500
- (22) International Filing Date: 6 December 2000 (06.12.2000)
- (25) Filing Language: English
- (26) Publication Language: English
- (30) Priority Data:
PQ 4558 9 December 1999 (09.12.1999) AU
- (71) Applicant (for all designated States except US): USF JOHNSON SCREENS PTY LTD. [AU/AU]; 88 Brickyard Road, Geebung, QLD 4014 (AU).
- (72) Inventors; and
- (75) Inventors/Applicants (for US only): EELES, John, William [AU/AU]; 14 Woodside Drive, Eleebana, NSW 2282 (AU). OLSEN, Peter, Martin [AU/AU]; 200 Brighton Avenue, Toronto, NSW 2291 (AU).
- (74) Agent: F B RICE & CO; 605 Darling Street, Balmain, NSW 2041 (AU).
- (81) Designated States (national): AE, AG, AL, AM, AT, AU, AZ, BA, BB, BG, BR, BY, BZ, CA, CH, CN, CR, CU, CZ, DE, DK, DM, DZ, EE, ES, FI, GB, GD, GE, GH, GM, HR, HU, ID, IL, IN, IS, JP, KE, KG, KP, KR, KZ, LC, LK, LR, LS, LT, LU, LV, MA, MD, MG, MK, MN, MW, MX, MZ, NO, NZ, PL, PT, RO, RU, SD, SE, SG, SI, SK, SL, TJ, TM, TR, TT, TZ, UA, UG, US, UZ, VN, YU, ZA, ZW.
- (84) Designated States (regional): ARIPO patent (GH, GM, KE, LS, MW, MZ, SD, SL, SZ, TZ, UG, ZW), Eurasian patent (AM, AZ, BY, KG, KZ, MD, RU, TJ, TM), European patent (AT, BE, CH, CY, DE, DK, ES, FI, FR, GB, GR, IE, IT, LU, MC, NL, PT, SE, TR), OAPI patent (BF, BJ, CF, CG, CI, CM, GA, GN, GW, ML, MR, NE, SN, TD, TG).
- Published:
— With international search report.
- For two-letter codes and other abbreviations, refer to the "Guidance Notes on Codes and Abbreviations" appearing at the beginning of each regular issue of the PCT Gazette.

(54) Title: A SCREENING MODULE AND A SCREENING ASSEMBLY INCLUDING SUCH MODULE

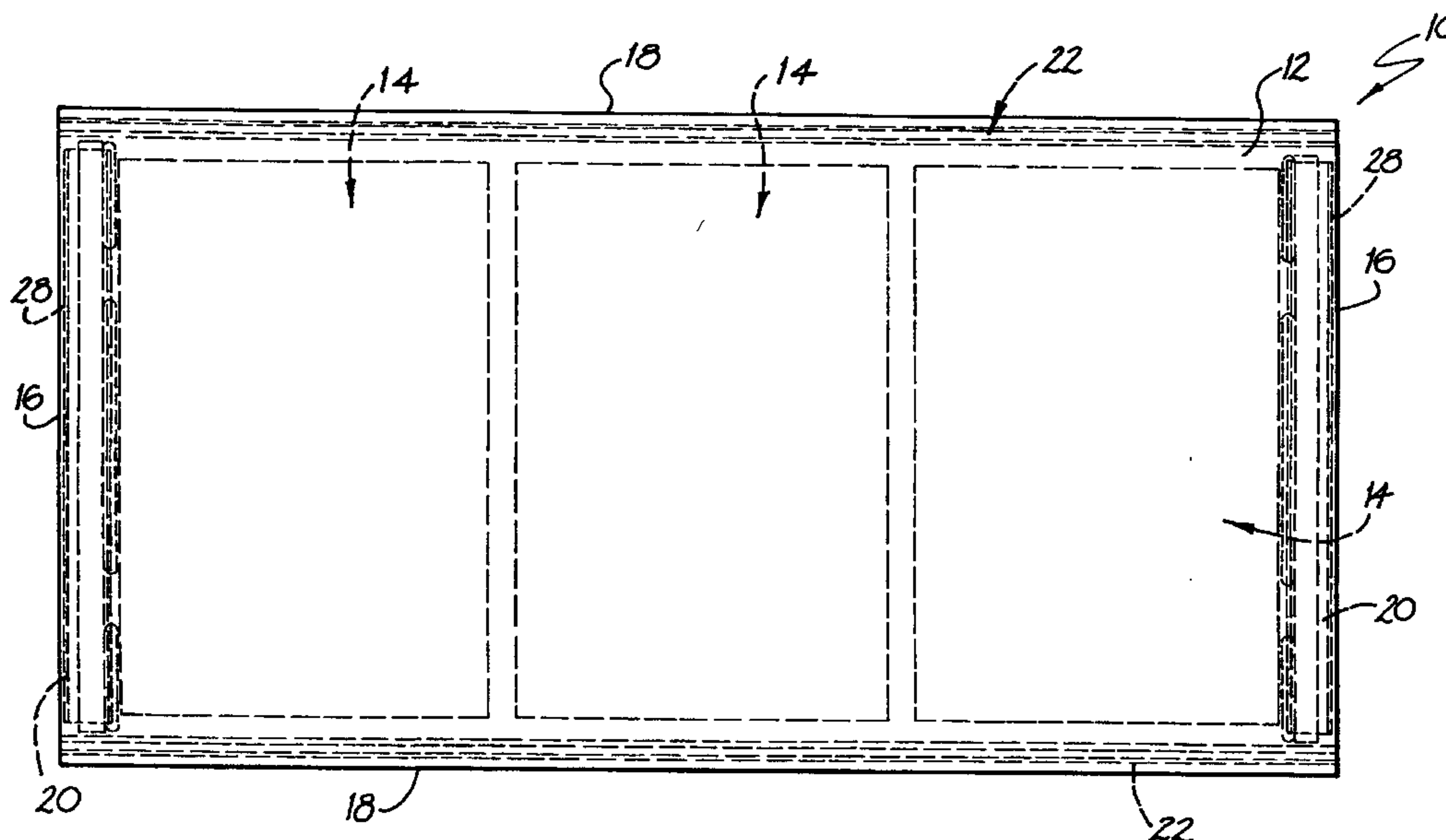

(57) Abstract: A screening module for a screening assembly includes a substantially rectangular, planar screening member having a plurality of screening apertures extending through it the member having a pair of sides extending parallel to a direction of flow of material over the member and a pair of sides extending transverse to a direction of flow of material over the member. A mounting means is formed integrally with the screening member as a one-piece unit for securing the member to an underlying structure. A part of the mounting means is arranged along each side of the screening member and only the parts of the mounting means associated with one pair of sides having reinforcing with the parts of the mounting means associated with the other pair of sides being without reinforcing.

WO 01/41944 A1

A screening module and a screening assembly including such module

Field of the Invention

This invention relates to a screening module. More particularly, the
5 invention relates to a screening module and to a screening assembly
including such module.

Summary of the Invention

According to the invention, there is provided a screening module for a
10 screening assembly, the module including

a substantially rectangular, planar screening member having a plurality
of screening apertures extending through it, the member having a pair of
sides extending parallel to a direction of flow of material over the member
and a pair of sides extending transverse to a direction of flow of material over
15 the member;

a mounting means formed integrally with the screening member as a
one-piece unit for securing the member to an underlying structure, a part of
the mounting means being arranged along each side of the screening member
and only the parts of the mounting means associated with one pair of sides
20 having reinforcing with the parts of the mounting means associated with the
other pair of sides being without reinforcing; and

a locating means associated with the parts of the mounting means of at
least one pair of sides of the screening member for locating the screening
member relative to the underlying structure, the locating means projecting
25 beneath an underside of the parts of the mounting means to abut against an
associated part of the underlying structure for inhibiting flexing and
dislodgement of the module relative to the underlying structure.

As indicated above, the screening panel is substantially rectangular.
The shorter sides of the panel may extend in a direction parallel to the
30 direction of flow of screening material over the module, in use. These shorter
sides shall be referred to as the longitudinal sides with the longer sides being
referred to as the transverse sides.

Preferably, only the longitudinal sides have the reinforcing. The
reinforcing may be steel reinforcing.

35 The locating means is, preferably, associated with the parts of the
mounting means having the reinforcing, ie. the longitudinal sides.

The locating means may be arranged operatively inwardly of its associated part of the mounting means, the reinforcing extending into the locating means.

5 Each part of the mounting means may be in the form of a clip arranged along its associated side of the screening member, the clip defining a receiving slot for receiving a complementary part of the underlying structure. The locating means may be in the form of a shoulder arranged inwardly of the slot of its associated clip and projecting beneath an underside of the clip to
10 abut against the associated part of the underlying structure. The reinforcing may define a pair of spaced, parallel plates, one arranged on each side of the slot. One of the plates may be longer to extend into the shoulder. The plates may be interconnected by a bridging portion arranged in the screening member above the slot, in use. Thus, the reinforcing may straddle the slot of
15 the clip.

The module may be a moulding of a synthetic plastics material. The plastics material may be a polyurethane. The type of polyurethane selected may be of a strength which allows a predetermined amount of flexing of the screening module, in use, to aid in screening of materials.

20 The invention extends also to a screening assembly which includes: a plurality of screening modules, each as described above; and a framework defining a structure underlying the screening modules, the screening modules being removably secured to the framework.

The framework may be a demountable framework. The framework
25 may includes rails to which the screening modules are releasably secured via the mounting means of the modules.

Brief Description of the Drawings

The invention is now described by way example with reference to the
30 accompanying diagrammatic drawings in which:

Figure 1 shows a plan view of a screening module in accordance with the invention;

Figure 2 shows an end view of the module;

Figure 3 shows a side view of the module;

35 Figure 4 shows a three dimensional, exploded view of a screening assembly, also in accordance with the invention;

Figure 5 shows a plan view of a component of the assembly;
Figure 6 shows a side view of the component of Figure 5 ;
Figure 7 shows an end view of the component of Figure 5;
Figure 8 shows a plan view of another component of the assembly;
5 Figure 9 shows a side view of the component of Figure 8; and
Figure 10 shows an end view of the component of Figure 8.

Detailed Description of the Drawings

Referring firstly to Figure 1 to 3 of the drawings, a screening module, in
10 accordance with the invention, is illustrated and is designated generally by
the reference numeral 10. The screening module 10 comprises a substantially
rectangular, planar screening member or deck 12 which defines a plurality of
screening apertures therethrough illustrated schematically by panels 14 in
Figure 1 of the drawings. The module 10 has a pair of transversely spaced,
15 longitudinal sides 16 and a pair of longitudinally spaced, transverse sides 18.
The longitudinal sides 16, in use, extend parallel to a direction of flow of
material over the module 10.

A mounting means in the form of a clip-like formation or clip 20 is
arranged along each longitudinal side 16. Similarly, a mounting means in the
20 form of a clip 22 is arranged along each transverse side 18. The clips 20 and
22 are shown in greater detail in Figures 2 and 3 of the drawings. It is to be
noted that each clip 20, 22 defines a slot 24 therein which clips over a rail 26
(Figure 4) as will be described in greater detail below.

The module 10 is formed integrally as a one-piece unit and is a
25 moulding of a synthetic plastics material. More particularly, a flexible
polyurethane material is used for the module 10.

To ensure that there is not too great a degree of flexing, in use, which
would result in the module 10 being torn loose from its underlying structure,
at least a part of the module 10 is reinforced.

30 In this regard, the sides 16 of the module 10 contain reinforcing 28
with the sides 18 being without reinforcing.

The reinforcing in the sides 16 extends into the clips 20 associated
with the sides 16. As illustrated in Figure 3 of the drawings, the reinforcing
28 straddles the slots 24 of the clips 20.

35 Thus, the reinforcing 28 comprises a plate 30 arranged inwardly of the
slot 24 with a further plate 32 arranged outwardly of the slot 24. The plates

30 and 32 are interconnected by a bridging portion 34 arranged in the deck 12.

In addition, also to control flexing of the module 10, a locating means in the form of a shoulder 36 is arranged along each side 16 inwardly of the clip 24. Each shoulder 36 abuts against a side rail (not shown) extending in a direction parallel to the direction of flow of material and controls flexing of the module 10. It is to be noted that, to improve the rigidity of the shoulder 36, the reinforcing plate 30 of the reinforcing 28 extends into the shoulder 36.

Referring now to Figure 4 of the drawings, a screening assembly is illustrated and is designated generally by the reference numeral 40. The screening assembly 40 includes a plurality of screening modules 10, only one of which is shown. The screening modules 10 are arranged in side-by-side and end-to-end relationship to form a screening surface over which material passes to be screened. The material moves in the direction of arrow 42.

The screening assembly includes a feed end frame 44, a discharge end frame 46 and an intermediate, connecting, frame 48. These frames clip into standard rails (not shown) to form an underlying structure 50 for the modules 10.

The feed end frame 44 and the discharge end frame 46 are of substantially the same construction and, accordingly, only one of the frames, the feed end frame 44, is discussed in greater detail. As illustrated in Figure 5 of the drawings, the feed end frame 44 comprises a ladder-like structure having a pair of side rails 52 interconnected by cross-members 54. Ends of the rails 52 have engaging formations 56 for engaging and being secured to underlying rails.

On one side of one of the side rails 52, opposite its junction with the cross-members 54, receiving formations 58 are defined for receiving connecting members 60 of the intermediate frame 48.

The receiving rail 26 runs along the top of each rail 52. Each receiving rail 26 includes clips 62 which are received in the slots 24 of the clips 20, 22 of the modules 10. The modules 10 are clipped on to the rails 26 by means of a dedicated "roll-on" tool to attach the modules 10 to the underlying structure 50 securely.

Referring again to the receiving formations 58, it is to be noted that each receiving formation 58 defines a slot 64 in which an end 66 of one of the connecting members 60 of the intermediate frame 48 is received. The end 66

of the connecting members 60 has ribs 68 which engage recesses 70 in the slots for connecting the intermediate frame 48 to the feed end frame 44 and the discharge end frame 46.

5 The intermediate frame 48 has a central spine 72 (Figures 8 to 10) from which the connecting members 60 project at right angles. A connecting formation 74 is arranged at each end of the spine 72 for connecting the intermediate frame 48 to the underlying rails.

10 As in the case of the feed end frame 44 and the discharge end frame 46, a connecting rail 26 is arranged on top of the spine 72 for securing the modules 10 to the intermediate frame 48.

15 It is a particular advantage of the invention that a screening module 10 is provided which can readily be "peeled" off the underlying structure 50 to be replaced without the need to disassemble the underlying structure 50. Also, due to the demountability of the underlying structure 50, should a component of the structure 50 be damaged, it can be readily replaced without replacing the whole underlying structure.

20 It will be appreciated by persons skilled in the art that numerous variations and/or modifications may be made to the invention as shown in the specific embodiments without departing from the spirit or scope of the invention as broadly described. The present embodiments are, therefore, to be considered in all respects as illustrative and not restrictive.

CLAIMS:

1. A screening module for a screening assembly, the module including
a substantially rectangular, planar screening member having a plurality
of screening apertures extending through it, the member having a pair of
5 sides extending parallel to a direction of flow of material over the member
and a pair of sides extending transverse to a direction of flow of material over
the member;
a mounting means formed integrally with the screening member as a
one-piece unit for securing the member to an underlying structure, a part of
10 the mounting means being arranged along each side of the screening member
and only the parts of the mounting means associated with one pair of sides
having reinforcing with the parts of the mounting means associated with the
other pair of sides being without reinforcing; and
a locating means associated with the parts of the mounting means of at
15 least one pair of sides of the screening member for locating the screening
member relative to the underlying structure, the locating means projecting
beneath an underside of the parts of the mounting means to abut against an
associated part of the underlying structure for inhibiting flexing and
dislodgement of the module relative to the underlying structure.
20
2. The module of Claim 1 in which the locating means is associated with
the parts of the mounting means having the reinforcing.
3. The module of Claim 2 in which the locating means is arranged
25 operatively inwardly of its associated part of the mounting means, the
reinforcing extending into the locating means.
4. The module of any one of Claims 1 to 3 inclusive in which each part of
the mounting means is in the form of a clip arranged along its associated side
30 of the screening member, the clip defining a receiving slot for receiving a
complementary part of the underlying structure.
5. The module of Claim 4 in which the locating means is in the form of a
shoulder arranged inwardly of the slot of its associated clip and projecting
35 beneath an underside of the clip to abut against the associated part of the
underlying structure.

6. The module of any one of the preceding claims which is a moulding of a synthetic plastics material.
7. The module of Claim 6 in which the plastics material is a polyurethane.
8. A screening assembly which includes:
 - a plurality of screening modules, each as claimed in any one of the preceding claims; and
 - a framework defining a structure underlying the screening modules, the screening modules being removably secured to the framework.
9. The assembly of Claim 8 in which the framework is a demountable framework.
10. The assembly of Claim 8 or Claim 9 in which the framework includes rails to which the screening modules are releasably secured via the mounting means of the modules.

1/7

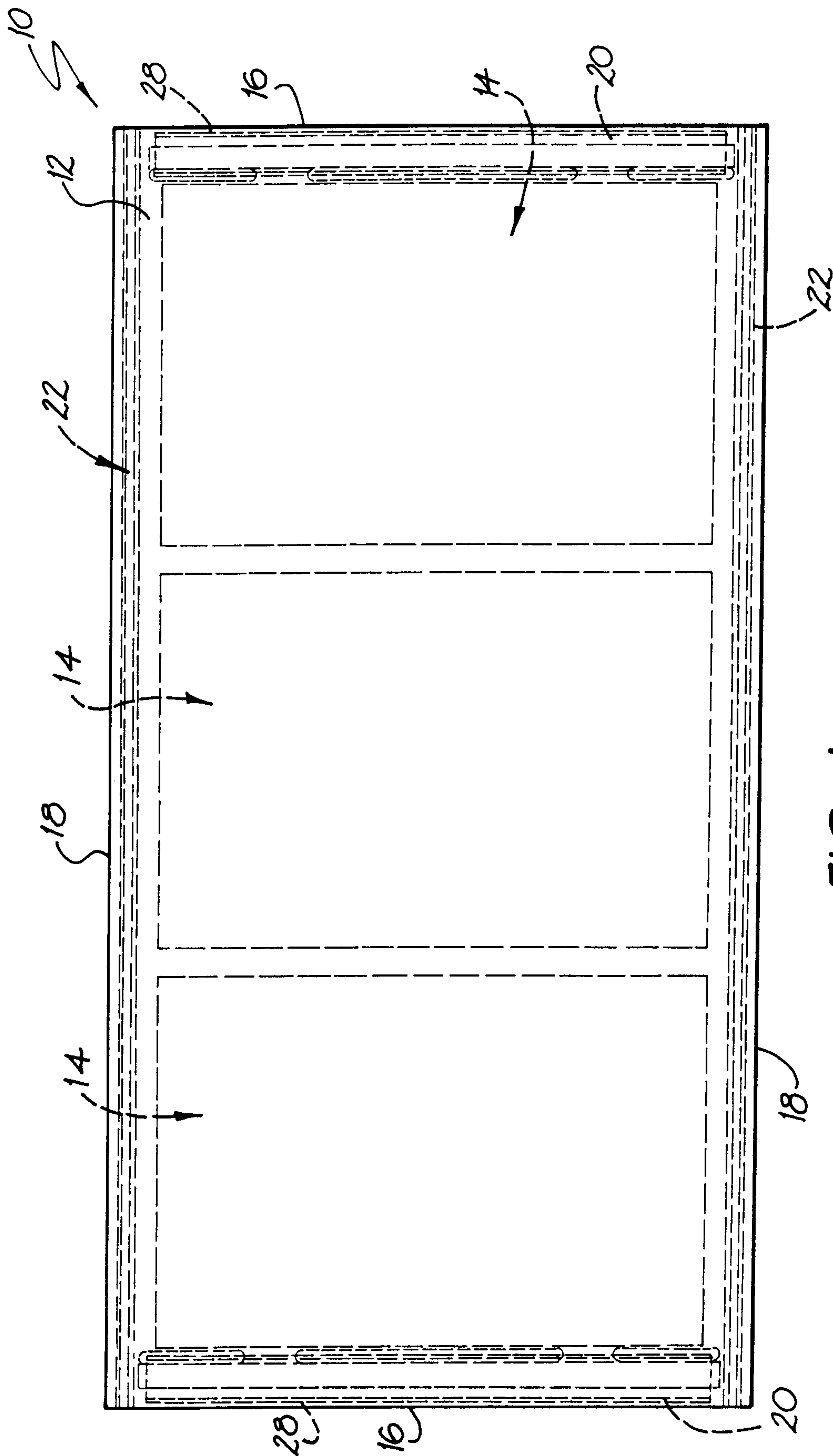

FIG. 1

217

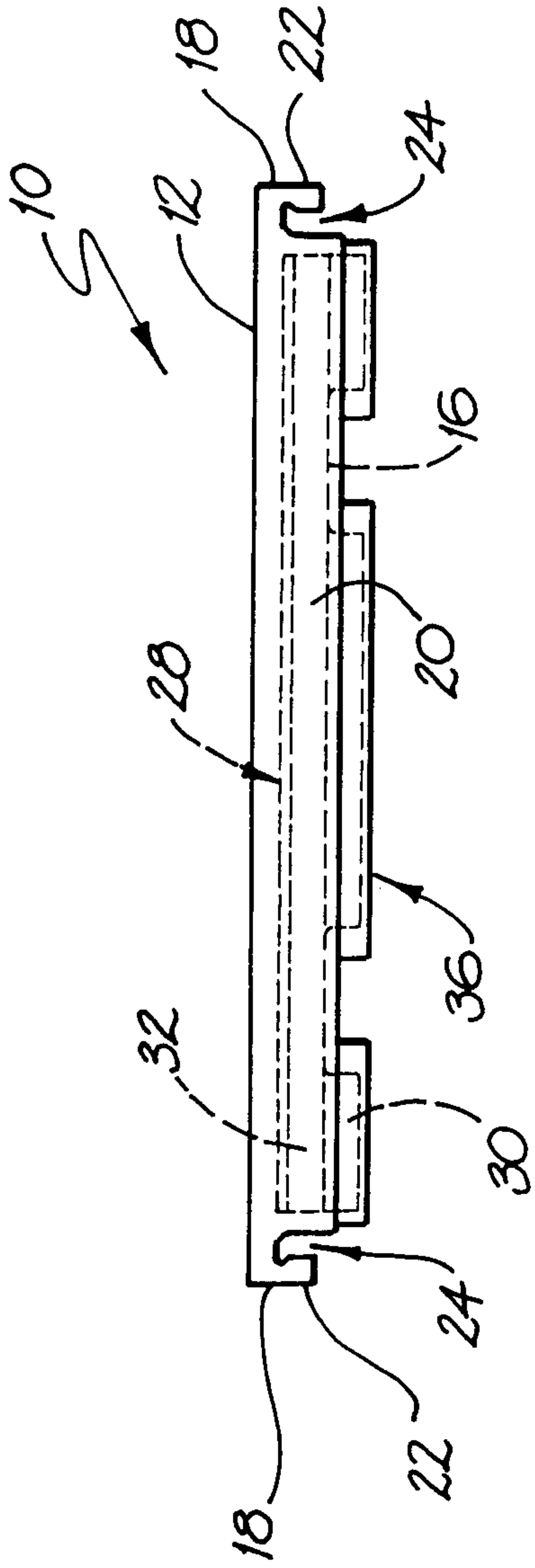

FIG. 2

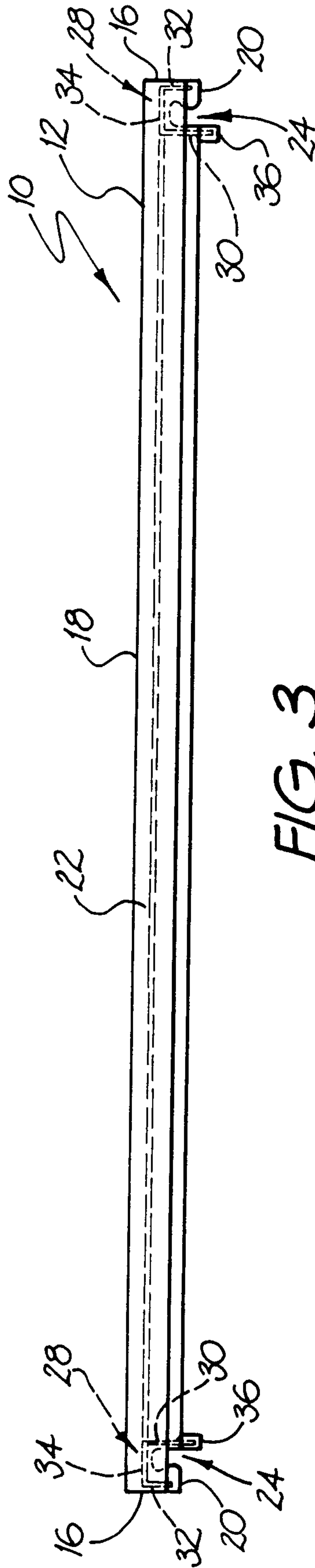

FIG. 3

3/7

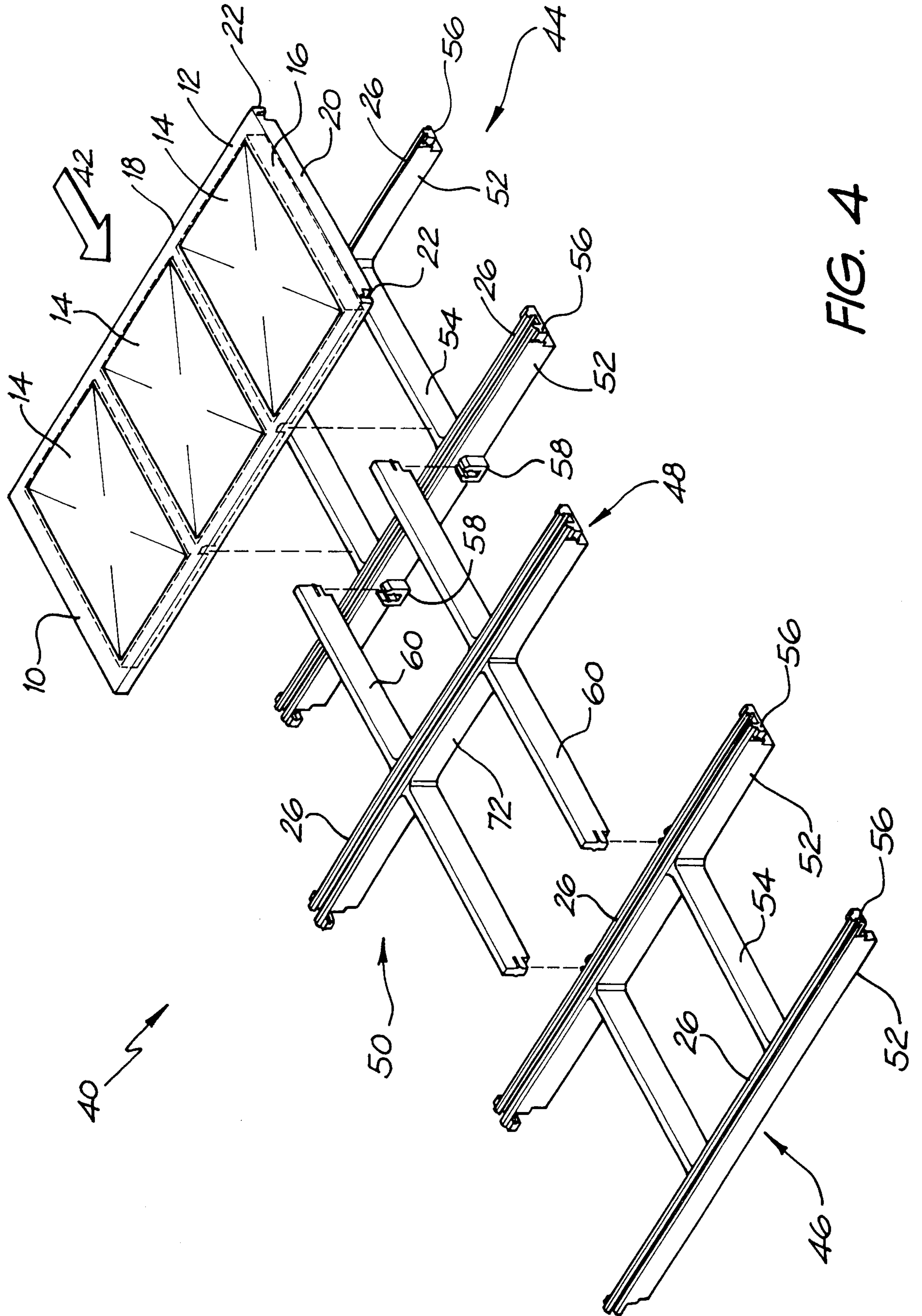

FIG. 4

4/7

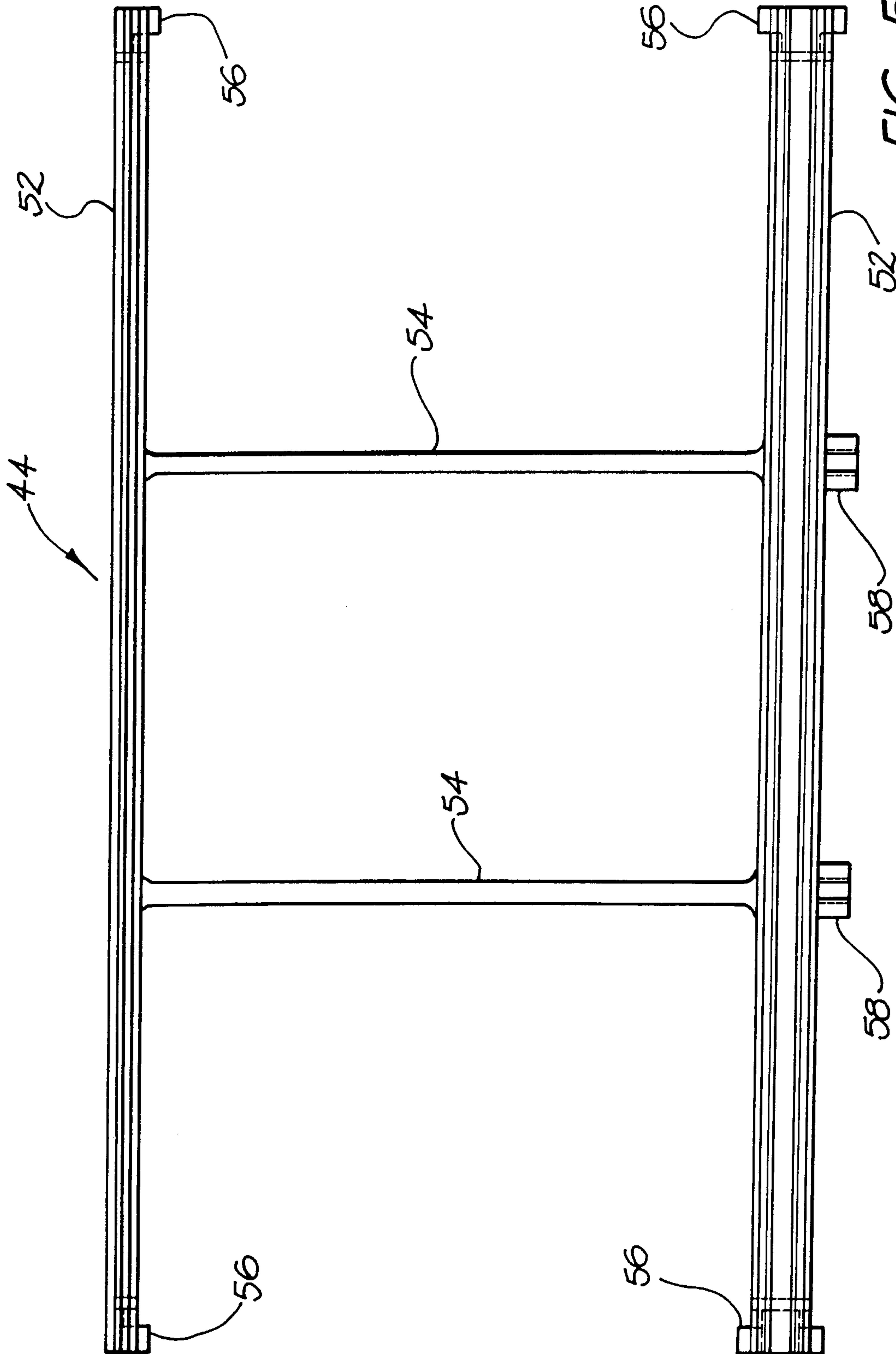

FIG. 5

5/7

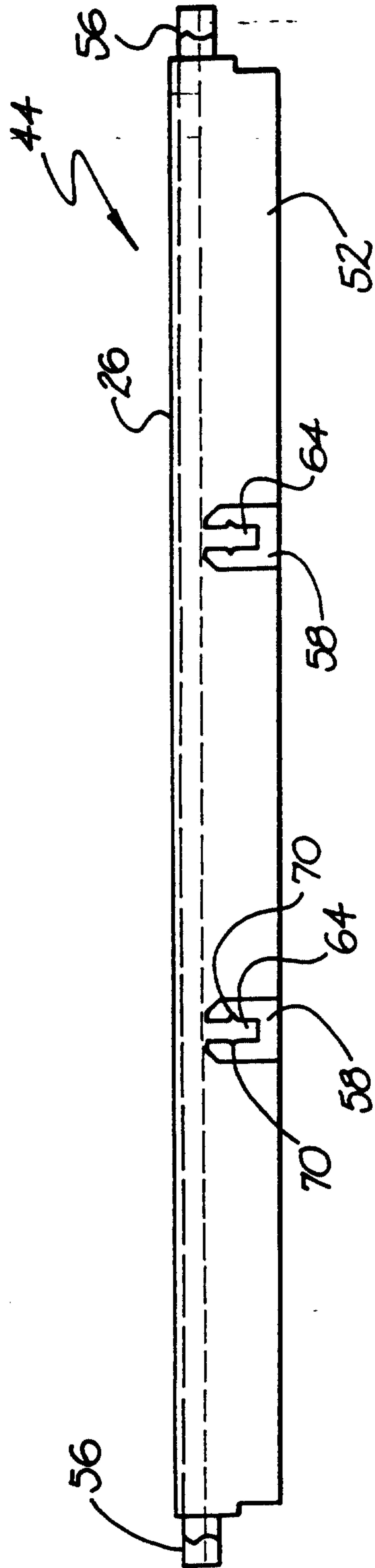

FIG. 6

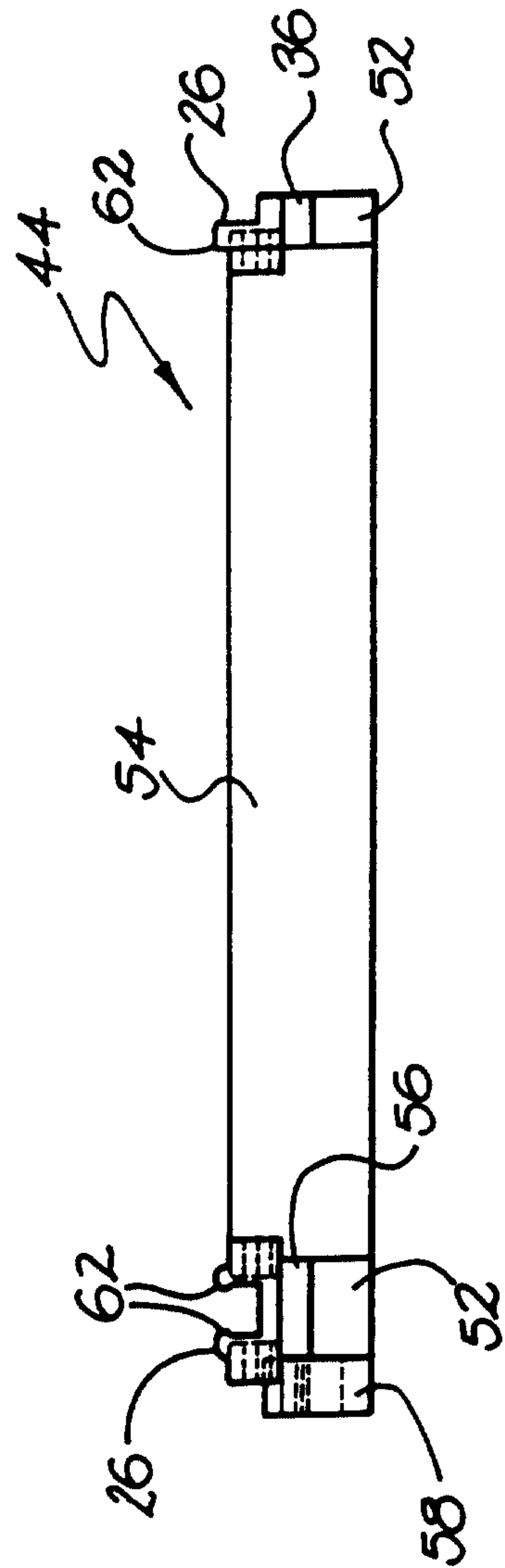

FIG. 7

6/7

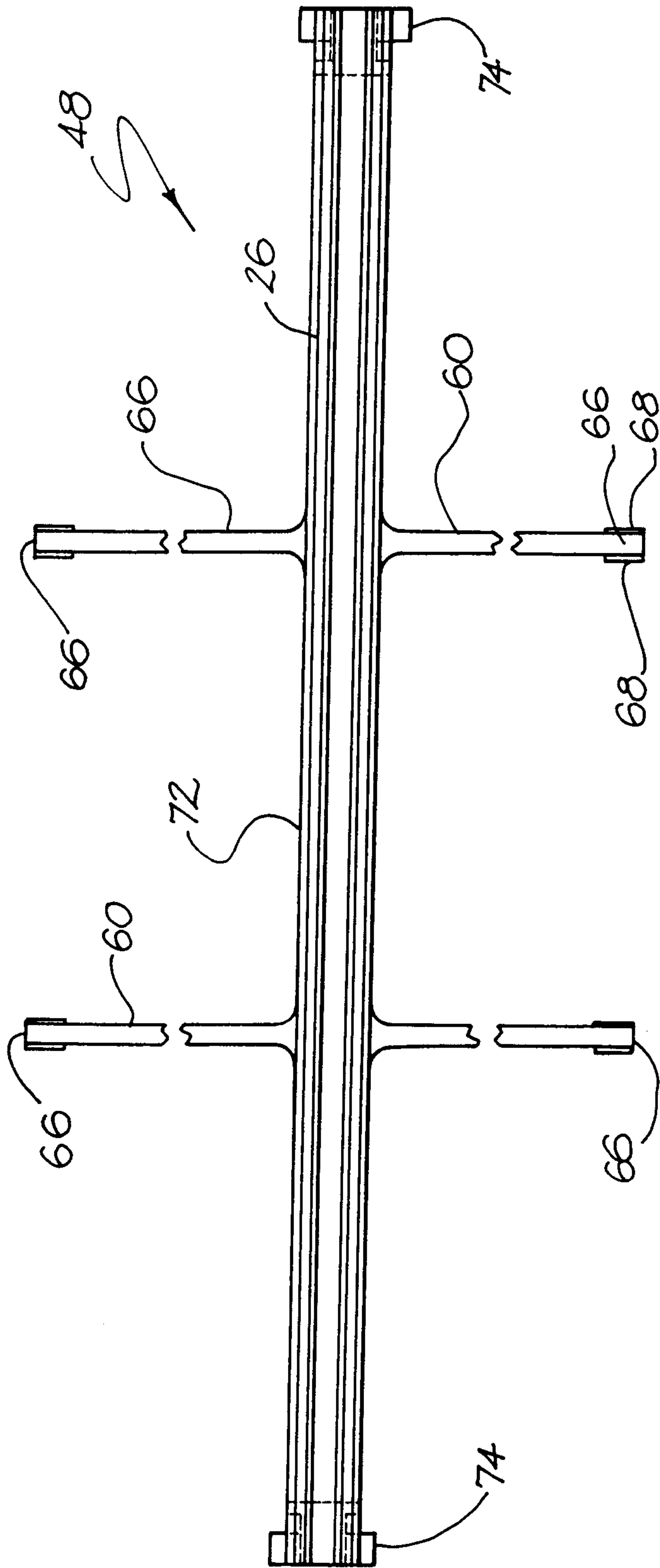

FIG. 8

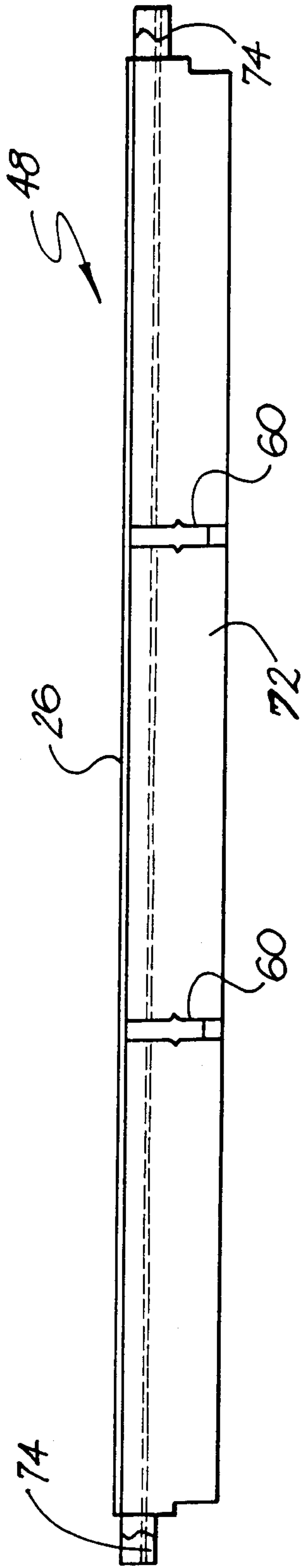

FIG. 9

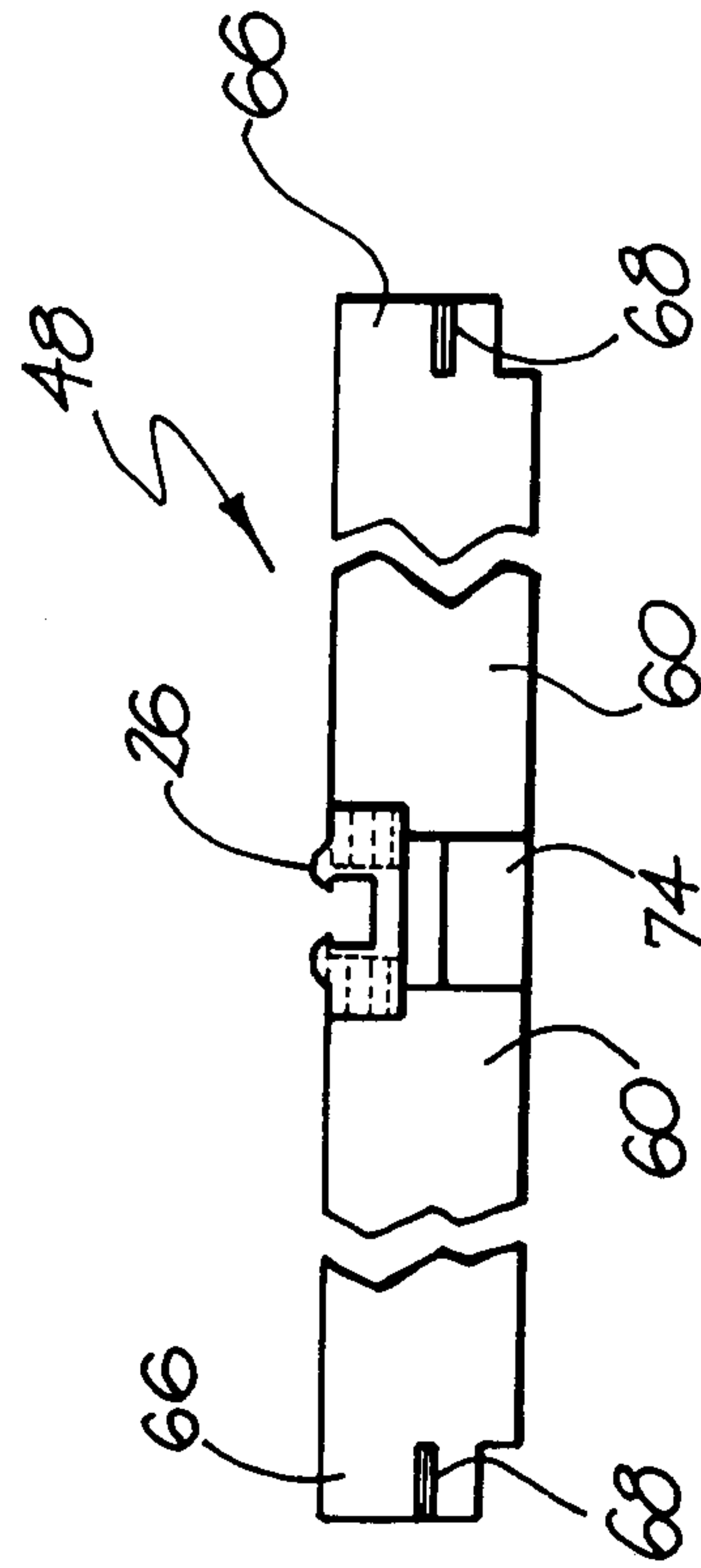

FIG. 10

