



(51) International Patent Classification:

F25D 11/00 (2006.01) F25D 17/06 (2006.01)  
F25D 13/06 (2006.01)

(21) International Application Number:

PCT/US2017/023052

(22) International Filing Date:

17 March 2017 (17.03.2017)

(25) Filing Language:

English

(26) Publication Language:

English

(30) Priority Data:

62/309,886 17 March 2016 (17.03.2016) US

(71) Applicant: FRESH CHILL SOLUTIONS, INC. [US/US]; 3225 S. MacDill Avenue 129-236, Tampa, FL 33629 (US).

(72) Inventors: SIGETY, Charles, Birge; 3225 S. MacDill Avenue 129-236, Tampa, FL 33629 (US). SIGETY, Katharine, Colyer; 3225 S. MacDill Avenue 129-236, Tampa, FL 33629 (US). DEWITT, William, John; 1527 Cottonwood Terrace, Dunedin, FL 34698 (US).

(74) Agent: MUELLER, Jason, P.; One Shell Square, 701 Poydras St., Ste. 4500, New Orleans, LA 70139 (US).

(81) Designated States (unless otherwise indicated, for every kind of national protection available): AE, AG, AL, AM, AO, AT, AU, AZ, BA, BB, BG, BH, BN, BR, BW, BY, BZ, CA, CH, CL, CN, CO, CR, CU, CZ, DE, DJ, DK, DM,

DO, DZ, EC, EE, EG, ES, FI, GB, GD, GE, GH, GM, GT, HN, HR, HU, ID, IL, IN, IR, IS, JP, KE, KG, KH, KN, KP, KR, KW, KZ, LA, LC, LK, LR, LS, LU, LY, MA, MD, ME, MG, MK, MN, MW, MX, MY, MZ, NA, NG, NI, NO, NZ, OM, PA, PE, PG, PH, PL, PT, QA, RO, RS, RU, RW, SA, SC, SD, SE, SG, SK, SL, SM, ST, SV, SY, TH, TJ, TM, TN, TR, TT, TZ, UA, UG, US, UZ, VC, VN, ZA, ZM, ZW.

(84) Designated States (unless otherwise indicated, for every kind of regional protection available): ARIPO (BW, GH, GM, KE, LR, LS, MW, MZ, NA, RW, SD, SL, ST, SZ, TZ, UG, ZM, ZW), Eurasian (AM, AZ, BY, KG, KZ, RU, TJ, TM), European (AL, AT, BE, BG, CH, CY, CZ, DE, DK, EE, ES, FI, FR, GB, GR, HR, HU, IE, IS, IT, LT, LU, LV, MC, MK, MT, NL, NO, PL, PT, RO, RS, SE, SI, SK, SM, TR), OAPI (BF, BJ, CF, CG, CI, CM, GA, GN, GQ, GW, KM, ML, MR, NE, SN, TD, TG).

Declarations under Rule 4.17:

- as to the identity of the inventor (Rule 4.17(i))
- as to applicant's entitlement to apply for and be granted a patent (Rule 4.17(ii))
- as to the applicant's entitlement to claim the priority of the earlier application (Rule 4.17(iii))

Published:

- with international search report (Art. 21(3))

(54) Title: METHODS, APPARATUSES, AND SYSTEMS FOR COOLING

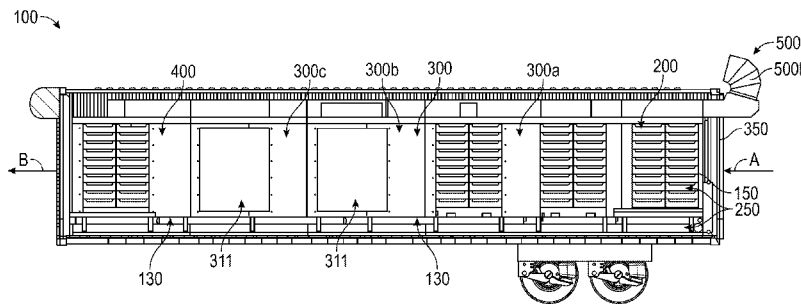
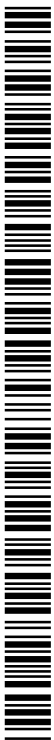

FIG. 5

(57) Abstract: Methods, apparatuses, and systems for cooling. Embodiments include a cooling system (100) comprising a mobile container (350), conveyor system, and sensor feedback system (250). Container (350) includes at least a first (200), second (300), and third (400) section. First section (200) holds at least one pallet (150) containing produce (1520, 152). Second section (300) includes a cooling mechanism (500, 600) to cool the produce (1520, 152) within the at least one pallet (150) to an optimal temperature. Third section (400) includes the cooling mechanism (500, 600) to maintain the cooled produce (1520, 152) in the at least one pallet (150) at the optimal temperature. Conveyor system may be used to convey the at least one pallet (150) across the cooling system (100). Sensor feedback system is configured to continuously measure and track at least the weight (1200) of the at least one pallet (150) and temperature of the produce (1520, 152) within the at least one pallet (150) as the at least one pallet (150) is conveyed across the cooling system (100).



**METHODS, APPARATUSES, AND SYSTEMS FOR COOLING**

This application claims the benefit of U.S. Provisional Patent Application No. 62/309,886, filed March 17, 2016, which is incorporated herein by reference.

5 **BRIEF DESCRIPTION OF THE DRAWINGS**

**FIG. 1** is a schematic of a cooling system, according to an exemplary embodiment of the present disclosure;

**FIG. 2** is a schematic of a cooling system, according to an exemplary embodiment of the present disclosure.

10 **FIG. 3A** is a front isometric view of a cooling system, according to an exemplary embodiment of the present disclosure;

**FIG. 3B** is a rear isometric view of the cooling system shown in **Figure 3A**;

**FIG. 4** is a top internal view of a cooling system, according to an exemplary embodiment of the present disclosure;

15 **FIG. 5** is a side cross-sectional view of an interior of a cooling system, according to an exemplary embodiment of the present disclosure;

**FIG. 6** is an illustration of an internal-external cooling mechanism of a cooling system, according to an exemplary embodiment of the present disclosure;

20 **FIG. 7** is a front isometric view of a cooling system, according to an exemplary embodiment of the present disclosure;

**FIG. 8** is a top internal view of the cooling system shown in **Figure 7**;

**FIG. 9** is a side cross-sectional view of the cooling system shown in **Figure 7**;

**FIG. 10** is a rear cross-sectional view of an interior of the cooling system shown in **Figure 9**;

25 **FIG. 11** is an isometric view of a cooling station of a cooling system, according to an exemplary embodiment of the present disclosure;

**FIG. 12** is a front view of the cooling station shown in **Figure 11** illustrating an internal cooling mechanism of the cooling system;

**FIG. 13** is a flowchart of a cooling system, according to an exemplary embodiment of the present disclosure;

5 **FIG. 13A** is a flowchart of a sensor feedback system, according to an exemplary embodiment of the present disclosure.

**FIG. 14** is a view of an output end the cooling system of the present disclosure.

**FIG. 15** is a view of an input end of the cooling system of the present disclosure.

10 **FIG. 16** is an internal view featuring aspects of a conveyor system of the present disclosure.

**FIG. 17** is an internal view featuring aspects of a conveyor system of the present disclosure. **FIG. 18A-E** is a flowchart of an independent remote packer model system for collecting, displaying and using produce data from harvest-to-sale.

15 **FIG. 19A-E** is a flowchart of a farm-based pack house model system for collecting, displaying and using produce data from harvest-to-sale.

### **DESCRIPTION OF EMBODIMENTS**

Produce begins to ripen and/or spoil as soon as it is harvested. Cooling the produce immediately and rapidly after harvesting slows this ripening and/or spoilage.

20 Existing cooling systems for produce are slower than desired and have led to decreased overall shelf life of the produce.

In some cooling systems, workers in the field may pack the produce in produce containers, such as cartons, trays or boxes, that are then stacked on pallets and transferred via a flatbed truck or other transportation to a distribution point. At

25 this distribution point, the cartons may be placed in a large refrigerated building to

cool the produce as quickly as possible. Other systems for cooling produce are disclosed in U.S. Patent Nos. 5,992,169, 5,375,431, and 5,386,703. These systems disclose apparatuses and methods for cooling produce via the use of vacuum chambers /pumps and hydro cooling.

5           Methods, apparatuses, and systems are provided for cooling produce via a cooling system. Embodiments include a cooling system having: a mobile container/trailer with separated sections to continuously cool produce to, and maintain the produce at, an optimal temperature; a conveyor system to convey produce across the sections of the mobile container; and a sensor feedback system to continuously  
10   measure, track, and receive relevant feedback/data regarding the produce. The sensor feedback system may be a dynamic real-time feedback system allowing a user to ensure that the produce is being cooled to an optimal temperature prior to being processed.

          In exemplary embodiments, relevant data (e.g., weight, temperature) regarding  
15   the produce may be continuously measured, tracked, displayed to a user, and/or stored in a database (locally and/or in the cloud). Importantly, this data may be obtained, tracked, and stored from as early as the point of harvest of the produce, at various points during cooling of the produce via the cooling system, and all the way up the supply chain to a distribution center, grocery store, and eventually, the customer.

20           Embodiments of the cooling system may include cooling mechanisms integrated within and/or attached to a mobile container/trailer that may be easily moved to different locations. As such, the cooling system may be mobile and brought directly to fresh produce during or right after harvesting. The result is optimized on-site cooling leading to longer shelf life for produce. The system also results in reduced

costs associated with handling and decreased time to market – all leading to fresher produce and substantial cost savings.

The inventions disclosed herein include a system for cooling produce. One embodiment of a system for cooling produce comprises a mobile container having a plurality of cooling stations therein. The mobile container has an input opening on a first end and an output opening on an opposing end thereof. The input and output openings are configured to receive produce containers therethrough. The mobile container has a staging section adjacent the input opening for receiving produce containers conveyed through the input opening. The staging section provides a cooled environment for initial cooling of produce. A rapid cooling section has first, second, and third cooling stations. The first cooling station is positioned to receive produce containers conveyed from the staging section, and has an associated cooling mechanism for cooling produce in the first cooling station. The second cooling station is positioned to receive produce containers conveyed from the first cooling station, and has an associated cooling mechanism for cooling produce in the second cooling station. The third cooling station is positioned to receive produce containers conveyed from the second cooling station, and has an associated cooling mechanism for cooling produce in the third cooling station. The first, second and third cooling stations together sequentially cooling produce to an optimal temperature by at least the third cooling station. A discharge section is positioned to receive produce containers conveyed from the third cooling station of the rapid cooling section and maintain produce at the optimal temperature. The discharge station is configured to convey produce containers out of the mobile container through the output opening.

The system can be provided with a conveyor system in the mobile container for conveying produce containers from the input end to the output end to thereby

sequentially transport produce containers through the staging, rapid cooling and discharge sections. A plurality of doors can be provided, the doors positioned to selectively close and thereby retain cold air for circulation within each of the first cooling station, the second cooling station, and the third cooling station during  
5 cooling of produce. Each of the plurality of doors can be an automatic roll-up door.

In some embodiments, the cooling mechanism in the first, second, and third cooling stations includes chilled air outputted via cooling fans and coils located on a first side of each of the first, second, and third cooling stations to thereby force chilled air over produce. Air is internally recirculated via return air ducts and fans located on  
10 an opposing second side of each of the first, second, and third cooling stations back to the cooling fans and coils located on the first side.

A sensor feedback system can be provided that is configured to continuously measure and track temperature of produce as produce containers are conveyed through the system. The sensor feedback system can be a dynamic real-time sensor  
15 feedback system. The sensor feedback system can be configured to measure and track the weight of produce as produce containers are conveyed through the system. In some embodiments, the sensor feedback system includes at least a first sensor integrated with the conveyor system, which is used to measure weight of at least one pallet upon entering the system, and a second sensor placed within the at least one  
20 pallet, which is used to measure the temperature of produce within the at least one pallet. The first and second sensors send at least one of weight and temperature information to a PLC device. The PLC device obtains at least the weight and temperature information of the produce and sends the weight and temperature information to at least one of a local storage and a cloud-based database. The sensor  
25 feedback system can include sensors mounted within the container that allow a user to

determine the location of the at least one pallet in the cooling system. The PLC device can be connected to and control at least one of the cooling mechanism, conveyor system, and sensor feedback system.

Methods of cooling produce are also provided. One method of cooling produce comprise inserting at least one pallet containing produce into a cooling system. The cooling system includes a mobile container including at least a separated first, second, and third section. The first section holds the at least one pallet containing produce in a semi-cooled environment. The second section includes a cooling mechanism to cool the produce within the at least one pallet to an optimal temperature. The third section includes the cooling mechanism to maintain cooled produce in the at least one pallet at the optimal temperature. A conveyor system is provided, the convey system including at least one conveyor longitudinally extending along the length of the mobile container. The conveyor system is used to convey the at least one pallet from the first section to each of the second and third sections. A sensor feedback system is configured to continuously measure and track at least the weight of the at least one pallet and temperature of the produce within the at least one pallet as the at least one pallet is conveyed across the cooling system. The method includes transporting the produce from the first section to the second section via the conveyor system; cooling the produce within the at least one pallet to the optimal temperature via the cooling mechanism; continuously measuring and tracking at least the weight and temperature of the produce within the at least one pallet via the sensor feedback system while conveying the at least one pallet along the second section to ensure the produce remains at the optimal temperature; transporting the produce from the second section to the third section via the conveyor system; and maintaining the produce within the at least one pallet at the optimal temperature.

In some embodiments, the second section includes a first cooling station, a second cooling station, and a third cooling station, each of which is configured to hold at the least one pallet being conveyed across the system. The cooling mechanism in the first, second, and third cooling stations can include chilled air outputted via vents located on a first side of the container to cool produce in the at least one pallet, with heat from the produce being exhausted out via vents located on an opposing second side of the container. In some embodiments, the cooling mechanism in the first, second, and third cooling stations includes chilled air outputted via cooling fans and coils located on a first side of each of the first, second, and third cooling stations to cool produce in the at least one pallet, with heat from the produce being internally recirculated via return air ducts and fans located on an opposing second side of each of the first, second, and third cooling stations back to the cooling fans and coils located on the first side.

In some embodiments, the sensor feedback system includes at least a first sensor integrated with the conveyor system, which is used to measure weight of the at least one pallet upon entering the system, and a second sensor placed within the at least one pallet, which is used to measure the temperature of the produce within the at least one pallet. The sensor feedback system can include sensors mounted within the container that allow a user to determine the location of the at least one pallet in the cooling system.

In some embodiments, the system comprises a mobile container including a cooling mechanism, the mobile container having separated sections to continuously cool produce to, and maintain the produce at, an optimal temperature via the cooling mechanism; a conveyor system to convey produce across the separated sections of the container; and a sensor feedback system to continuously measure, track, and store



relevant information regarding the produce being conveyed across the container, and to control the movement of the conveyor system based on this information. The cooling mechanism can include an external cooling mechanism that interacts with an internal cooling mechanism installed within the container to cool the produce. The cooling mechanism can be an entirely internal cooling mechanism installed within the container.

In some embodiments, the system for cooling produce comprises a mobile container having an input opening on a first end and an output opening on an opposing end thereof. The input and output openings are configured to receive produce containers therethrough. The mobile container has a staging section adjacent the input opening for receiving produce containers conveyed through the input opening. The staging section provides a cooled environment for initial cooling of produce. The system includes a rapid cooling section configured for cooling produce to an optimal temperature. A discharge section is positioned to receive produce containers conveyed from the rapid cooling section and maintain produce at the optimal temperature. The discharge station is configured to convey produce containers out of the mobile container through the output opening. The rapid cooling section can comprise: a first cooling station positioned to receive produce containers conveyed from the staging section, the first cooling station having an associated cooling mechanism for cooling produce in the first cooling station; a second cooling station positioned to receive produce containers conveyed from the first cooling station, the second cooling station having an associated cooling mechanism for cooling produce in the second cooling station; and a third cooling station positioned to receive produce containers conveyed from the second cooling station, the third cooling station having an associated cooling mechanism for cooling produce in the

third cooling station. The first, second and third cooling stations together sequentially cool produce to the optimal temperature by at least the third cooling station.

In some embodiments a conveyor system is provided in the mobile container for conveying produce containers from the input end to the output end to thereby sequentially transport produce containers through the staging, rapid cooling and discharge sections. In some embodiments, the conveyor system includes at least seven conveyors extending along each of the first section, second section, and third section of the container. A plurality of doors can be provided, the the doors positioned to selectively close and thereby retain cold air for circulation within each of the first cooling station, the second cooling station, and the third cooling station during cooling of produce. The doors can be automatic roll-up doors. In some embodiments, the mobile container is fixed on a wheeled trailer chassis for use in moving the mobile container.

In some embodiments, the cooling mechanism in the first, second, and third cooling stations includes chilled air outputted via vents located on a first side of the container to flow chilled air over produce and then into exhaust vents located on an opposing second side of the container. In some embodiments, the cooling mechanism in the first, second, and third cooling stations includes chilled air outputted via cooling fans and coils located on a first side of each of the first, second, and third cooling stations to thereby force chilled air over produce, with air being internally recirculated via return air ducts and fans located on an opposing second side of each of the first, second, and third cooling stations back to the cooling fans and coils located on the first side. The cooling mechanism in the third section can include chilled air outputted via vents located on opposing sides of the container to thereby force chilled air over produce from opposing sides.

Referring to **Figure 1**, a schematic of cooling systems **100, 1000** is shown. **Figure 2** is a schematic showing cooling systems **100, 1000** in communication with local and cloud-based databases.

Cooling systems **100, 1000** may include sensor feedback system **250**,  
5 conveyor system **130**, and computer **280**, each located in a mobile container **350** and  
each interconnected together and connected to and controlled by a Programmable  
Logic Controller (PLC) **260** mounted within container **350** via hard wired and  
wireless connections. Sensor feedback system **350** may be used to obtain relevant data  
from produce, from produce containers **150**, such as pallets **150**, containing produce,  
10 and from mobile container **350**, and send the data to computer. Computer **280** may  
continuously receive this data and output the data to a web address/user interface **282**  
accessible by a user from any user computing device, and/or to local or cloud-based  
databases. See **Figures 1** and **2**.

The relevant data being received and stored in the database may include but is  
15 not limited to: type of produce, important properties of the produce (e.g., weight,  
temperature), date of harvest of produce, location of the farm where the produce was  
harvested, specific location of the produce in the farm at the point of harvest, etc.

In one embodiment, cooling system **100** may include an internal-external  
cooling mechanism **500** installed within, and/or attached to exterior of, mobile  
20 container **350**, respectively.

In an alternative embodiment, cooling system **1000** may include only an  
internal cooling mechanism **600** installed within mobile container **350**.

Cooling systems **100, 1000**, sensor feedback system **250**, cooling mechanisms  
**500, 600**, conveyor system **130**, and computer shown in **Figures 1** and **2** may be

implemented using the apparatuses, systems and methods further described herein, including various embodiments thereof.

PLC or other suitable controller/control technologies may be configured to convert user input signals from a user interface device **282** connected to the PLC **260**  
5 into control signals for controlling components of systems **100, 1000**. User interface device may be for e.g. a computing device such as a mobile device (smart phone; smart tablet, etc.).

In embodiments, PLC may be mounted within container **350**. In a particular embodiment, PLC may be located in a control panel/electrical panel between  
10 ductwork of container **350** and a sidewall of container **350**. In other embodiments, PLC may be located external to systems **100, 1000** and remotely control components within systems **100, 1000**. Connection between the PLC and user interface device may be any wireless connection such as RF, infrared, or any other suitable communication technology. In an exemplary embodiment, PLC may be an Allen-  
15 Bradley CompactLogix™ 5370 controller (1769-L18ERM-BB1B).

PLC may be configured to connect and deliver control signals to systems **100, 1000** to control components of systems **100, 1000**, including cooling mechanisms **500, 600**, conveyor system **130**, and/or sensor feedback system **250** described herein. For e.g., PLC may deliver control signals to motors **132** attached to conveyor system  
20 **130** to control speed of conveyor system **130**. Further, in an embodiment, PLC may connect and deliver output signals to external cooling mechanisms such as refrigeration equipment to perform cooling mechanism in system **100**. User input signals and control signals may be either digital or analog, and the PLC or other suitable controller may be configured to accept and/or output either. In some  
25 embodiments, PLC may accept information regarding produce from a wired RFID

(radiofrequency identification) reader. In other embodiments, an electrical box including an industrial computer **280** connected to a wireless receiver may be wired to the PLC, which computer may wirelessly collect and/or transmit information regarding produce. See, e.g., **Figure 1**.

5           Cooling systems **100, 1000** of the present disclosure may include any communications via bluetooth, Wi-Fi, hard wire internet, cell phone signal, and/or satellite signal, depending on the application.

          Referring to **Figures 3A to 5**, different views of cooling system **100** are shown. Figure 3A is a front isometric view of cooling system **100**. Figure 3B is a rear  
10 isometric view of cooling system **100**. **Figure 4** is a top internal view of cooling system **100**. **Figure 5** is a side cross-sectional view of an interior of cooling system **100**.

          Cooling system **100** may be a container/trailer attached to a trailer chassis. See, e.g., **Figures 3A, 3B, and 5**. In exemplary embodiments, cooling container/trailer  
15 **350** may be approximately thirty five to forty feet long. In some embodiments, container **350** may include a hard ground cover to hold an approximately 60,000 lb mobile cooling container attached to a trailer chassis. However, cooling system **100** is not limited to this particular configuration, and containers and/or trailers of other suitable sizes / lengths / widths may be used in embodiments of the present disclosure.

20           As indicated in **Figure 7**, in particular embodiments, container **350** may include stainless steel airtight sections/chambers **200, 300 (300a, 300b, 300c), 400** dragged into and bolted within container **350**. In this embodiment, gaskets may be used to seal each section with each other. Further, insulation may be installed between the outside of each steel section and an exterior cladding of the mobile container **350**.

25           Tracks may be positioned on opposing sides of each steel section to assist in insertion

and installation of each section. In other embodiments, cooling container **350** may be a box/chamber that is inserted and bolted into a standard reefer/box trailer or placed onto a flat deck trailer, such that produce packed in, for e.g. palletized lugs, may be placed into the unit **350** for cooling. For e.g., container **350** may be fit into a fifty-  
5 three-foot long reefer trailer. In yet other embodiments, container **350** may be “Intermodal”, and designed to be moved from one mode of transport to another (e.g. from ship, to rail, to truck).

In some embodiments, cooling system **100** may be integrated into existing harvesting systems, packaging systems, and/or a building or other structure for further  
10 refrigeration, packaging, and processing. In an exemplary embodiment, harvesting system may be an Oxbo 7420 harvester that can output at least three pallets **150** of produce every forty-five minutes. In other embodiments, cooling system **100** may be integrated into a semi-trailer system to act as a “factory in the field” that performs harvesting, processing, cooling, and/or packaging of produce at one location.

15 Cooling container/trailer **350** may include an opening in a front and back end **351, 352** of the container **350** to allow for insertion and removal of produce packed in, for e.g., palletized lugs/pallets **150**. For e.g., one end opening of the cooling container **350** may include a dock seal built into a frame of the container **350**, so that a standard reefer trailer, smaller field trailer, forklift, and/or similar structure may unload pallets  
20 **150** directly into the container **350** for cooling. An opposing end opening of the cooling container **350** may be configured to unload chilled produce **152** in pallets **150** directly onto, for e.g., a fresh fruit packing line, a refrigerated trailer, and/or an opening in a refrigerated building. In some embodiments, a protruding, airtight, rolling door **122** may be attached to this opposing end opening of container **350**. See,  
25 e.g., **Figure 3A**. In other embodiments, each end opening of the container **350**

adjacent to door **122** may include a plate, trailer door, or other structure to cover up the opening during transport. End openings of container **350** may therefore allow for increased versatility and adaptability of system **100** to different types of processes.

Cooling system **100** may include connections/attachments to attach/plug in system **100** to various other systems, including but not limited to cooling systems, power systems, etc. For e.g., cooling container **350** may be powered via attachments to a variety of connections to back up different ton units. In a particular embodiment, container **350** may be powered via attachments to a three-phase power source that may be, for e.g., a landline or generator, as well as a 25+ ton refrigerator (Air Conditioning Unit) that integrates with a PLC mounted within the container **350**.

Referring to **Figures 4** and **5**, cooling container/trailer **350** of cooling system **100** may include at least a separated first staging section **200**, second rapid cooling section **300**, and third discharge section **400**. In an exemplary embodiment, first section **200**, second section **300**, and third section **400** may be made from stainless steel. However, first section **200**, second section **300**, and third section **400** may be made from other suitable materials, including any materials that can be cleaned and disinfected per applicable food processing rules and requirements.

As shown in **Figure 4**, first section **200**, second section **300**, and third section **400** are separated via swinging doors **122** or roll-up doors **122**. Swinging doors **122** may be configured to separate each of the first, second, and third sections **200**, **300**, **400**, while simultaneously allowing at least one pallet **150** containing produce to be easily conveyed from the first section **200** to the second section **300** to the third section **400**. Alternatively, first section **200**, second section **300**, and third section **400** may be separated via other suitable movable structures, e.g., flexible clear plastic flaps/doors or fabric rollup doors **122**, to allow for produce to pass between the

sections of container **350**. In some embodiments, a rollup door **122** may be fitted with sensors that act to automatically open and shut the rollup door **122** as at least one pallet **150** is conveyed across the system **100**.

At least one pallet **150** containing produce may be successively conveyed  
5 from the first section **200** to the second and third sections **300**, **400** of the container **350** via a conveyor system **130**. See, e.g., **Figure 4**. Conveyor system **130** may include at least one conveyor/movable belt **136** longitudinally extending along the length of the mobile container/trailer **350** and across the first section **200**, second section **300**, and third section **400**. In an exemplary embodiment, conveyor system  
10 **130** may include a series of conveyors longitudinally extending along the entire length of the container **350**/cooling system **100**. In an embodiment, chain conveyors may be mounted inside a steel piping system within container **350**. See, e.g., **Figure 4**. Chain conveyors may vary in size and/or graduate into each other. As shown in **Figure 4**, one conveyor may be located in first section **200**, three conveyors may be located in  
15 second section **300**, and one conveyor may be located in third section **400**. In an alternative embodiment, conveyor system **130** may include at least seven five foot long conveyors extending along each of the first section **200**, second section **300**, and third section **400** of the container **350**.

As indicated in **Figures 16-17**, in embodiments, conveyors in conveyor  
20 system **130** may be inserted into the floor of container **350** via conveyor guides **134** and welded to the floor of container **350**. Conveyors **130** may be located within a single section **200**, **300**, **400** or may cross over into different sections **200**, **300**, **400**.

Conveyor system **130** may be driven via connections to electric motors **132** mounted in container **350**. As indicated in **Figures 16-17**, motors **132** may be  
25 mounted on either side of conveyor system **130**. In an exemplary embodiment, five



motors **132** may independently control each conveyor in conveyor system **130**. In other embodiments, conveyor system **130** may be hydraulically driven or driven via other suitable systems. The speed of the conveyors in the conveyor system **130** may be adjustable as needed. For e.g., conveyors in conveyor system **130** may move up to 5 30 feet per minute. In an embodiment, speed of the conveyor system **130** may be controlled via connections to a variable frequency drive (VFD) controlled by a PLC mounted within container **350**. In an exemplary embodiment, speed of the conveyor system **130** may be controlled through an Allen-Bradley PowerFlex<sup>®</sup> 525 AC Drive via EtherNet/IP with an Allen-Bradley CompactLogix<sup>™</sup> 5370 controller.

10 Referring back to **Figures 4** and **5**, first section **200** of cooling container **350** is configured to act as a staging chamber and hold at least one pallet **150** containing fresh harvested produce in a semi-cooled environment. In this embodiment, first section **200** is not ventilated with any ductwork. At least one pallet **150** may be held in the first section **200** prior to conveyance into the second section **300** via the 15 conveyor system **130**. In an exemplary embodiment, first section **200** holds two pallets **150**. See, e.g., **Figure 4**. Alternatively, first section **200** may hold more or less pallets **150**. In an embodiment, first section **200** may be ten feet long. However, first section **200** may have a larger or smaller size.

Second section **300** of cooling container **350** is configured to receive at least 20 one pallet **150** containing fresh produce from the first section **200** and cool the produce. Particularly, second section **300** may be utilized as a cooling area including cooling mechanisms to cool the produce within the at least one pallet **150** to an optimal cooled temperature. In an exemplary embodiment, berries, such as blueberries, in at least one pallet **150** may be cooled to an optimal temperature of 25 approximately 50 to 55 degrees Fahrenheit. However, other types of produce may be

cooled in the cooling system **100** to its corresponding optimal cooled temperature. In an embodiment, second section **300** may be twenty feet long. However, second section **300** may be larger or smaller.

Although the optimal produce temperature is between about 50 to about 55  
5 degrees, it may be desirable in some cases to cool the produce to below 50 degrees F., or even to just above freezing, such as to about 34 degree F. The mobile cooling container **350** can be configured to efficiently reduce produce to such temperatures in a short amount of time. When produce, such as fruit, is processed on a production line, it is sometimes desirable to provide the fruit in a near-frozen state, the theory  
10 being that near-frozen produce is harder and therefore more resistant to bruising, which can result from drops or other rough handling while on the production line. However, once fruit has been brought to a near frozen state, care must be taken to avoid allowing the fruit to warm up, which results in condensation and rapid spoilage. Additionally, for most purposes described herein, care must be taken to ensure that  
15 the produce remains at a temperature above freezing at all times; this is because once produce is frozen, it is considered “processed” and cannot be marketed or sold as “fresh.” In order to facilitate these particular purposes, the mobile container 350 can be configured or set (e.g. by a thermostat or other controller) to drop the temperature of the fruit to just above freezing, such as 34 degrees F, by the third station **300c**. The  
20 almost-frozen fruit is then removed from the container **350** and introduced into a production line. Robots can be used at the end of the trailer to load the fruit onto the production line. The production line area is a discrete area from the loading area and the pack off area. A production line takes in fruit that is very close to freezing and runs it through to the pack line. Although the produce arrives in a near-frozen  
25 temperature, the ambient air in the working part of the production line can optionally

be warmer, such as about 50 degrees F, because it only takes about 1-2 minutes to traverse a production line with modern sorting equipment. The short exposure to the higher temp would likely not result in condensation, the enemy for enhancing spoilage. However, to avoid the risk of warming and condensation, the intake and discharge sections of the production line can be held near 34 degrees F. Typically, the boxed and packaged fruit is kept in the low 30s after being packed.

As shown in **Figures 4 and 5**, second section **300** includes a first cooling station **300a**, second cooling station **300b**, and third cooling station **300c**, each of which may hold at least one pallet **150**. However, second section **300** may utilize more or less cooling stations to cool produce within pallets **150** being transported across system **100**. Further, each cooling station within second section **300** may hold more or less pallets **150**.

Second section **300** may include an internal-external cooling mechanism **500** to cool produce in at least one pallet **150**. See **Figures 3A and 5**. **Figure 6** illustrates an example embodiment of the workings of internal-external cooling mechanism **500** in first cooling station **300a**, second cooling station **300b** and/or third cooling station **300c**.

Internal-external cooling mechanism **500** as disclosed in embodiments of the present disclosure may include any forced air central systems, including but not limited to systems attached to ducts/ductwork, air handlers, air terminals/vents including supply air outlets and return or exhaust air inlets, etc. In an embodiment, cooling mechanism **500** may cool produce via connections to forced air refrigeration, whereby cooled/chilled air may be drawn through the produce and recycled via a heat exchanger. In this embodiment, container **350** may be attached via internal and external ductwork to external forced air refrigeration equipment (see **Figure 6**), which

equipment may be a mechanical, expansion/compression type refrigeration system where a compressed refrigerant gas may be passed into expansion coils. Water may be drawn from a retention sump and cascaded over the coils within a heat exchanger, and expanding refrigerant gas may draw heat from the water. Air may then be drawn  
5 upward through the chilled water cascade to remove heat from the air, and the resulting cooled/chilled air may then be pushed/forced into the container **350** through inlet ducts **500a** via fans mounted outside the container **350**. See **Figures 3A, 3B,** and **6**. Chilled air may be blown at the produce in pallet **150** (shown as direction **A** in **Figure 6**) to remove ambient heat from the produce, and the resulting warmed air  
10 may then be pulled back out and through return outlet ducts **500b** (shown as direction **B** in **Figure 6**), and eventually cycled back through the externally located water cascade. The process may then be repeated until a desired/optimal reduction in temperature of the produce is reached.

Internal-external cooling mechanism **500** may include a lightweight  
15 detachable air inlet and outlet system attached to a track system mounted on a top exterior of container **350**. See **Figure 3A, 3B, 5,** and **6**. For e.g., two air inlets **500a** may be positioned between two air outlets **500b**, with the air inlets **500a** and outlets **500b** mounted on a top exterior of container **350** adjacent to first section **200**. See **Figures 3A, 3B,** and **6**. As shown in **Figures 3A, 3B,** in embodiments, the four air  
20 inlets **500a** and/or outlets **500b** may constitute flexible ducts **500a, 500b** that attach (via for e.g. hoses) to an external AC unit/refrigeration trailer such as for e.g., a Trane® AC unit. See **Figure 6**. In exemplary embodiments, the four air inlets **500a** and/or outlets **500b** may protrude up to a foot and a half out from the frame of the container **350**. See **Figures 3A, 3B,** and **5**.

In exemplary embodiments, RA inline fans **600a**, **600d** may be placed outside container **350** between an external AC/refrigeration unit **500** and container **350**. See **Figure 6**. Inline fans **600a**, **600d** may have a variable speed and rotation of inline fans may be controlled via Variable Frequency Devices (VFDs) connected to a PLC  
5 mounted within container **350**. In an exemplary embodiment, fans may be inline fans offered by Greenheck Fan Corporation.

Placement of inline fans and external AC unit may be dependent on wind direction. For e.g., inline fans and attached AC unit and generator may be placed downwind of container **350** to avoid exhaust fumes from a diesel generator. Inline  
10 fans are utilized in order to increase the Cubic Feet per Minute (CFM) in container **350** by ensuring that air moves quickly through the flexible duct inlets **500a** and outlets **500b** mounted adjacent to the first section **200** and external to the container **350**. See **Figures 3A**, **3B**, and **5**. It is important to move air quickly through the flexible ducts and into insulated ducts in the container **350** since heat can be lost as  
15 the air is pushed through these flexible ducts.

As shown in **Figure 5**, each of first cooling station **300a**, second cooling station **300b**, and third cooling station **300c** may include at least one duct opening **311** for attachment of ductwork to perform cooling mechanism **500** in second section **300**. In an exemplary embodiment, at least one duct opening **311** may be an approximately  
20 50-inch x 64-inch sized rectangular opening. However, at least one duct opening **311** may have other suitable sizes or configurations to assist in cooling of produce and for attachment of different sized cooling systems. In an exemplary embodiment, insulated ducts may be inserted into the container **350** and welded to duct openings **311** in a stainless steel metal frame of each station **300a**, **300b**, **300c** of second section **300**.

Features can be provided to improve accessibility to the system **100, 1000**, such as for maintenance of the various components. Sidewalls of the mobile container **350** can be provided with access openings at strategically selected locations along the length of the mobile container **350**. For example, an access opening can be provided adjacent to any or all of the cooling stations **300a, 300b, 300c**. The access openings allow access to components of the cooling system for monitoring of operations and maintenance of components. The access openings can be provided with doors for selectively sealing and unsealing the openings to provide access to the interior of the mobile container **350**. The doors can be various forms, such as roll-up, sliding, hinged, and the like, depending on the needs and operating conditions. Since openings typically reduce insulation, the openings and doors may be provided with air tight seals, such as through the use of gaskets and compression latches.

In particular embodiments, internal-external cooling mechanism **500** may include chilled air blown at high velocity over produce in at least one pallet **150** to take ambient heat out of the produce. See, e.g, **Figures 4 and 6**. As the berries may be “piled” as high as six inches in the pallets **150**, the blast of air being blown at the produce must be strong enough to reach the center of each pallet **150**. To accomplish this strong air flow, chilled air may be blown at produce in varying speeds and from opposing sides of the produce as it is transported across the second section **300**. In some embodiments, chilled air may have a temperature of +/- 5 degrees of a preset targeted exit temperature for when the produce exits the second section **300**. In other embodiments, the produce may simply be exposed to colder air with a temperature much lower than a targeted exit temperature so as to speed up the cooling process in system **100**.

As shown in **Figures 4** and **5**, at least one pallet **150** may be located at first cooling station **300a**. Internal-external cooling mechanism **500** in first cooling station **300a** may include cooled air outputted via vents located on a first side of the first cooling station **300a** to cool produce in at least one pallet **150**, with ambient heat from the produce being exhausted out via vents located on an opposing second side of the first cooling station **300a**.

At least one pallet **150** may then be moved down to second cooling station **300b** via conveyor system **130**. Cooling mechanism **500** in second cooling station **300b** may include cooled air outputted via vents located on a first side of the second cooling station **300b** to cool produce in at least one pallet **150**, with ambient heat from the produce being exhausted out via vents located on an opposing second side of the second cooling station **300b**.

At least one pallet **150** may then be moved down to third cooling station **300c** via conveyor system **130**. Cooling mechanism **500** in third cooling station **300c** may include cooled air outputted via vents/ducts located on a first side of the third cooling station **300c** to cool at least one pallet **150**, with ambient heat from the produce being exhausted out via vents located on an opposing second side of the third cooling station **300c**.

In exemplary embodiments, input and output vents may be positioned on opposing sides of adjacent stations **300a**, **300b**, **300c** in an alternating, staggered configuration. As shown in Figure 4, vents on the first and second side of the second cooling station **300b** are positioned on the same side as vents on the second and first side of the first cooling station **300a** and third cooling station **300c**, respectively. Alternatively, other configurations for cooling may be used in cooling system **100**.

Vents/ducts in the first side of the first, second, and third cooling stations **300a**, **300b**, **300c** may each include at least one mechanized damper controlled by a PLC via an analog connection. At least one mechanized damper may close and open to control how much air is entering/flowing into the first, second, and third cooling stations **300a**, **300b**, **300c** and onto produce in at least one pallet **150**. Vents/ducts in second side of first, second, and third cooling stations **300a**, **300b**, **300c** may each include at least one air velocity sensor configured to communicate with the PLC **260** connected to VFDs of inline fans **600a**, **600d** described herein to instruct the fans **600a**, **600d** to speed up to facilitate pulling of air up and out the system **100**.

Once cooling mechanism **500** of second section **300** cools produce in at least one pallet **150** to a desired optimal temperature, at least one pallet **150** containing chilled produce may be moved to third section **400** of container **350** via conveyor system **130**. Third section **400** may include a cooling mechanism **500** substantially similar to cooling mechanism in second section **300**. Particularly, third section **400** may act as an outlet chamber and maintain chilled produce in the at least one pallet **150** at the desired/exit temperature via cooled air outputted via vents located on opposing sides of the third section **400** onto the at least one pallet **150**. Further, third section **400** may also include at least one duct opening **311** for attachment of ductwork to perform cooling mechanism in third section **400**. See, e.g., **Figure 5**. In an exemplary embodiment, insulated ducts may be inserted into the container **350** and welded to duct openings **311** in third section **400**.

Third section **400** may maintain the chilled produce in the at least one pallet **150** at the optimal temperature until it is ready for unloading and transportation to another area for further refrigeration and processing. In some embodiments, at least one pallet **150** containing chilled produce may be removed from the third section **400**



via an un-motorized conveyor ramp to a cold storage location where it may be held at the exit temperature. Cold storage location may be a cold/refrigerated reefer trailer and/or other movable or non-movable structures having the capability to store and maintain the produce at a desired temperature.

5           In alternative embodiments, at least one pallet **150** containing chilled produce may be removed from container **350**/system **100** via other mechanisms, e.g., automated conveyors, lifts, etc. In some embodiments, a user may physically open a door adjacent to third section **400** to accept at least one pallet **150** containing chilled produce. In other embodiments, a user may automatically open the door via systems  
10 such as screw drive, belt drive, and/or chain drive garage door opener systems. Once the door is open, at least one pallet **150** may be removed off conveyor system **130** in the third section **400** by a user via for e.g., a hand pallet jack.

          Cooling system **100** may further include a sensor feedback system **250** including at least one sensor placed within the at least one pallet **150** containing  
15 produce and/or attached to an interior of container **250**. See, e.g., **Figure 4**. At least one sensor may be but is not limited to an air velocity sensor described herein, temperature sensor, humidity sensor, position sensor such as a photoelectric sensor (photo eye), proximity sensor, and/or pressure sensor. At least one sensor may further be any device (such as a load sensor/cell further described herein) used to measure  
20 and track weight of pallet **150** containing produce.

          Sensor feedback system **250** may be automated or operated by a user.

          Sensor feedback system **250** may be a dynamic, real-time system configured to continuously measure, track, and obtain feedback/information regarding the produce within the at least one pallet **150** being transported through the container  
25 **350**/cooling system **100**. As described herein, sensor feedback system **250** may output

this information directly to a PLC and/or computer via hardwired and/or wireless connections, which information may then be stored and/or outputted to a web address/user interface accessible by a user computing device such as, e.g., a mobile device, and/or directly to a user computing device. See **Figures 1 and 2**.

5           In particular embodiments, sensor feedback system **250** may include temperature monitoring devices/sensors placed within at least one pallet **150** containing produce. Temperature sensors may be placed at various locations within the at least one pallet **150**. For e.g., temperature sensors may be placed within bins of produce located in the middle and/or outer edges of at least one pallet **150**. In  
10           embodiments, each pallet **150** may include at least four temperature sensors, with each pallet **150** being approximately sixty inches tall. In an exemplary embodiment, temperature sensors may be an RFID temperature sensor **705** manufactured by Phase IV Engineering, Inc. Temperature sensors **705** may be used to obtain information  
15           the at least one pallet **150**, the specific location of the produce with that temperature within the at least one pallet **150**, as well as the location of the at least one pallet **150** itself.

          In various embodiments, sensor feedback system **250** may include eleven position sensors to track location of at least one pallet **150** on a conveyor system **130**.  
20           For e.g., photoelectric sensors (photo eyes) may be used to determine the distance, absence, and/or presence of at least one pallet **150** by using a light transmitter (generally infrared) and a photoelectric receiver. Photo eyes may be removably mounted on one side of container **350** and wired into an electrical box attached to conveyor system **130**. In an exemplary embodiment, one photo eye may be mounted  
25           at the beginning and end of each of five conveyors in a conveyor system **130**, as well

as at the entrance of the container **350** to track whether at least one pallet **150** has entered the container **350**. In this embodiment, at least one pallet **150** passing the first photo eye may indicate that it is fully on a conveyor, and at least one pallet **150** passing any subsequent photo eyes may indicate its corresponding position on the conveyor system **130**.

In some embodiments, sensor feedback system **250** may further include capacitive proximity switches/sensors mounted in container **350** to act as secondary sources for reading whether there is any weight on the conveyors in conveyor system **130**, thereby allowing a user to determine the location of at least one pallet **150** on conveyor system **130**. Furthermore, utilizing the photo eyes and/or capacitive proximity sensors may allow a user to determine when at least one pallet **150** is transferred between conveyors **136** in conveyor system **130**, and therefore, when to turn these conveyors on and off.

Sensor feedback system **250** may also include humidity sensors attached to an interior of the container **350** to track the humidity within the container **350**. In a particular embodiment, one humidity sensor may be placed in each of the first cooling station **300a**, second cooling station **300b**, third cooling station **300c**, and third section **400**. Particularly, one humidity sensor may be placed in the internal walls of ducts in each of the first cooling station **300a**, second cooling station **300b**, third cooling station **300c**, and third section **400**. In this embodiment, each humidity sensor may be located on one side of container **350** and wired into an electrical box attached to conveyor system **130**. In alternative embodiments, any number of humidity sensors may be located in any location within each section **200**, **300**, **400** of the container **350**.

In exemplary embodiments, sensor feedback system **250** may include an RFID feedback system whereby load/weight, temperature and/or humidity sensors may send

relevant weight, temperature and/or humidity information via wired and/or wireless connections to an RFID reader **701** attached to an interior of container **350**. RFID reader may be configured to pull relevant sensor information via a wireless Near Field Communication (NFC) connection. In embodiments, RFID reader may be connected  
5 (wirelessly or by wired connections) to a PLC such that the RFID reader may transmit relevant temperature and/or humidity information to the PLC. PLC may then transmit the temperature and/or humidity information via a Wi-Fi connection to a web address/user interface accessible by a user computing device **282** such as for e.g., a mobile device. See, e.g., **Figure 1**. In an exemplary embodiment, RFID reader **701**  
10 may be the SIMATIC RF670R device from Siemens AG.

In a particular embodiment, an RFID reader antenna **703** may wirelessly read RFID tags **705** inserted/placed within the at least one pallet **150** to determine the current temperature of the produce within the at least one pallet **150**. This temperature reading may be received and stored by the RFID reader **701**, which RFID reader **701**  
15 may then transmit the reading to a PLC **260** connected to the RFID reader **701**. In other embodiments, Wi-Fi temperature and/or humidity sensors may wirelessly transmit the reading directly to a PLC. In either embodiment, the PLC may output the reading to a web address/user interface accessible by a user computing device. See, e.g., **Figure 1**. A recurring RFID/ electronic feedback loop may then track the  
20 location of the at least one pallet **150** and/or monitor the amount of cooling in the container **350** to ensure temperature of the produce is consistent with an expected/preset temperature for produce upon exiting the second section **300** and/or third section **400**, and to prevent freezing.

Sensor feedback system **250** may further be used to control the movement of  
25 the conveyor system **130** described herein based on the temperature measurement

being tracked as at least one pallet **150** is moved down cooling container **350**. Sensor feedback system **250** may control the conveyor system **130** via connections to the PLC **260** mounted in container **350**. In embodiments, the speed of the conveyor system **130** may be varied based on the size of the pallet **150** and temperature of the produce within the pallet **150** upon entrance into the first section **200** of container **350**.

In exemplary embodiments, different run options may be utilized to move at least one pallet **150** across container **350** via conveyor system **130** connected to the PLC **260** described herein. In one embodiment, at least one pallet **150** may be continuously inserted into and moved through the container **350** such that at least one pallet **150** traverses the entirety of the container **350** in a range of approximately fifteen to forty five minutes. In an embodiment of this “continuous” cooling embodiment, at least one pallet **150** may be moved through the second section **300** at a rate of 1 minute/foot in a slow but consistent manner. In other embodiments, system **100** may cool approximately three pallets **150** every forty-five minutes.

In another “stop and go” embodiment, at least one pallet **150** may be immediately moved to first cooling station **300a** where cooled air may be outputted via vents/ducts onto produce in the at least one pallet **150**. Temperature sensors in sensor feedback system **250** may then measure and track temperature of produce in at least one pallet **150** until temperature reaches an optimal temperature, at which point at least one pallet **150** may be immediately moved to second cooling station **300b**, and then successively to third cooling station **300c** and third section **400** for additional tracking and cooling.

In yet another “accrual” embodiment, a reefer may not be available for unloading at least one pallet **150** containing chilled produce, so multiple pallets **150**

containing chilled produce may be loaded onto conveyors in conveyor system **130** and accrued within container **350**. This embodiment allows a user to cool and store multiple pallets **150** of produce even if options to unload the pallets **150** are not yet available.

5 In embodiments, once the at least one pallet **150** is brought to the desired exit temperature and held in the third section **400** of the container **350**, an operator / user outside of the cooling container **350** may assist in ejection/removal of the at least one pallet **150** as described herein. In other embodiments, sensor feedback system **250** may be automatically preset via RFID controls to output the at least one pallet **150** on  
10 a timed basis by opening the automatic roll up door **122** when it is at the optimal temperature.

Sensor feedback system **250** may be powered via connections to a power source located in the container **350**. Power source may include other forms of power, e.g., a battery, direct wired connection into the container **350** itself, etc.

15 As shown in **Figures 14** and **15**, cooling system **100** may further include a visual/lighting system **180** located on an exterior of the container **350**. As shown in **Figure 14**, the visual system **180** may be provided on the output opening end **352** of the mobile container **350**. As shown in **Figure 15**, the visual system **180** can be provided on the input opening end **351** of the mobile container **350**. Visual system  
20 **180** may be mounted onto container via either permanent or non-permanent attachment mechanisms, for e.g., an adhesive. Visual system may be controlled by a PLC mounted in container **350**. In embodiments, visual system may include red and green lights **182**, **184**, **186** configured to provide notification to an operator to load a new pallet **150** into the container **350**. In this embodiment, visual system may show  
25 the red light **182** to indicate to the operator to hold off on loading/unloading the pallet

150 and a green light 186 to indicate to the operator to proceed to load/unload the pallet 150. In other embodiments, red, yellow, and green lights 182, 184, 186 may be mounted to the outside of each of the first and third sections 200, 400. For e.g., the three lights 182, 184, 186 may each be mounted on opposing sides of a rolling door  
5 described herein attached to the outside of the third section 400. In this embodiment, visual system may show the red light to indicate to the operator that a pallet 150 is inside the container 350 but not ready for unloading, a yellow light to indicate that the pallet 150 is moving into the third section 400 for unloading, and a green light to indicate to the operator that the pallet 150 is ready for unloading. In some  
10 embodiments, red, yellow, and green lights may be a row of red, yellow, and green LEDs (light-emitting diodes). Alternatively, cooling system may include other suitable visual, audio, and/or audiovisual systems to notify a user to load pallets 150 in the container 350.

Figures 7 to 10 show different views of cooling system 1000, an alternative  
15 embodiment of cooling system 100. Figure 7 is a front isometric view of cooling system 1000. Figure 8 is a top internal view of cooling system 1000. Figure 9 is a side cross-sectional view of an interior of cooling system 1000. Figure 10 is a rear cross-sectional view of an interior of cooling system 1000.

Cooling system 1000 may have substantially the same features as cooling  
20 system 100, including but not limited to container 350 (and first section 200, second section 300, first cooling station 300a, second cooling station 300b, third cooling station 300c, and third section 400), conveyor system 130, sensor feedback system 250, at least one pallet 150, PLC, and computer sending produce and/or container 350 data to a user and/or databases. See Figures 1 and 2.

As shown in **Figures 9** and **10**, cooling system **1000** includes a scale **700** integrated/installed with (for e.g., a chain drive of) conveyor system **130** and used to measure weight of the at least one pallet **150** upon entering the system **1000**. Scale **700** may be any type of load cell/sensor that may be used to measure weight of at least one pallet **150**. Load cell/sensor may be any physical element/transducer that may translate pressure (force) into an electrical signal. In embodiments, load cells/sensors of scale **700** may be connected to and send relevant weight information to PLC and/or computer in system **1000**. See, e.g., **Figure 1**. The computer may be configured to output this weight information to a web address/user interface accessible by a user from any user computing device (see, e.g., **Figure 1**) and/or to continuously receive and store the weight information in a database in computer storage and/or in a database in the cloud (see, e.g., **Figure 2**).

Further, as shown in **Figures 6** to **8**, this embodiment of cooling system **1000** includes fabric rollup doors **122** that separate first section **200**, second section **300**, and third section **400**. Rollup door **122** may be fitted with sensors that act to automatically and quickly open and shut the rollup door **122** as at least one pallet **150** is conveyed across the system **1000** so as to prevent leakage of cold air from each section **200**, **300**, **400**.

Unlike cooling system **100**, which includes an internal-external cooling mechanism **500**, cooling system **1000** includes a completely internal cooling mechanism **600** installed within container **350**. This particular configuration of internal cooling mechanism **600** allows for elimination of all ductwork (including inlets **500a** and outlets **500b**) in internal-external cooling mechanism **500**, thereby allowing for faster and more optimal cooling of the produce in at least one pallet **150**.



**Figure 11** is an isometric view of an example embodiment of a cooling station **300a, 300b, 300c** of second section **300** of cooling system **1000** that employs a “closed loop” based internal cooling mechanism **600**. **Figure 12** is a front view of cooling station **300a, 300b, 300c** shown in **Figure 11** illustrating the workings of  
5 internal cooling mechanism **600**.

As shown in **Figures 11** and **12**, cooling mechanism **600** may be an internal air handler system that includes cooling fans **600a** placed adjacent to cooling/condenser refrigeration coils **600b** in an interior of each cooling station **300a, 300b, 300c** such that chilled air is forcefully blown at at least one pallet **150** to  
10 thereby quickly cool produce in at least one pallet **150**.

Refrigeration coils **600b** and cooling fans **600a** of cooling mechanism **600** may be utilized in substantially the same manner to cool produce in at least one pallet **150** as the external coils and fans in the internal-external cooling mechanism **500** as described herein, but with the entire cooling process being performed internally  
15 within each cooling station **300a, 300b, 300c**. See, e.g, **Figure 12**.

In an exemplary embodiment, a row of cooling fans **600a** may be installed in a first side of an interior of each cooling station **300a, 300b, 300c**. Cooling/condenser refrigeration coils **600b** may be installed in interior of each respective cooling station **300a, 300b, 300c** such that coils **600b** are adjacent to both cooling fans **600a** and at  
20 least one pallet **150**. Opposing ends of chilled fluid lines **600e** may be attached to coils **600b** and to a portable commercial chiller **500**. See **Figure 12**. Commercial chiller **500** may be located external to container **350** or, in an exemplary embodiment, may be installed to a bottom exterior surface of container **350**. As shown in **Figure 12**, chilled fluid lines **600e** include an input and return line.

In exemplary embodiments, fluid may be chilled in the commercial chiller and then introduced into each cooling station **300a**, **300b**, **300c** via chilled fluid lines **600e**. Fluid may be water or glycol based. A damper system can be used to control the air along with the fans. For certain products or climates, it may be necessary or  
5 helpful to introduce or exhaust moisture laden air from the container **350** or individual compartments **200**, **300**, **400** thereof. Fans **600a** may then be activated to blow air at coils **600b** to thereby allow for chilled air in the range of approximately 32 to 50 degrees to be blown at produce in at least one pallet **150** in direction **A** to remove ambient heat from the produce. See **Figure 12**. Warmed air from the produce may  
10 then be pushed up within each cooling station **300a**, **300b**, **300c** via return air duct **600c** and return air fans **600d** in direction **B** and recirculated/cycled back in direction **C** towards cooling fans **600a** for re-cooling. This process may be repeated until a desired/optimal reduction in temperature of the produce is reached.

Cooling fans **600a** and return air fans **600d** may include any type of inline fans  
15 having a variable speed and a rotation that may be controlled via VFDs connected to a PLC mounted within container **350**.

Each station **300a**, **300b**, **300c** and at least one pallet **150** may include sensor feedback system **250** described herein. Sensor feedback system **250** and related sensors may be used to measure, track, and send relevant temperature information  
20 regarding the produce in at least one pallet **150** as well as regarding the air being circulated within each station **300a**, **300b**, **300c**. Sensors may continuously provide this information to PLC and/or computer installed within container **350**, which information may be used to provide feedback and control cooling of at least one pallet **150**, including control of amount of chilled fluid entering each station **300a**, **300b**,  
25 **300c**, and variability of speed of cooling fans **600a** and return fans **600d**.

In exemplary embodiments, cooling mechanism **600** may have a similar alternating, staggered configuration as internal-external cooling mechanism **500** described herein. Fans **600a** and coils **600b** in first cooling station **300a** and third cooling station **300c** may be positioned in an opposing side to fans **600a** and coils **600b** in second cooling station **300b**. See **Figure 8**. Similarly, return air ducts **600c** and return air fans **600d** in first cooling station **300a** and third cooling station **300c** may be positioned in an opposing side to return air ducts **600c** and return air fans **600d** in second cooling station **300b**. See, e.g., **Figures 8** and **12**. Alternatively, other configurations for cooling may be used in cooling system **1000**.

**Figure 13** is a flowchart showing cooling systems **100**, **1000** as described herein using sensor feedback system **250** as described herein. **Figure 13A** is a flowchart showing a temperature reading process of sensor feedback system **250** as described herein. Cooling systems **100**, **1000** and sensor feedback system **250** described in **Figures 13** and **13A** may be implemented using the apparatuses, systems and methods described herein, including various embodiments thereof. As shown in **Figure 13**, cooling systems **100**, **1000** may include the following steps.

At least one pallet **150** containing freshly harvested produce may be inserted into the first section **200** of container **350** described herein and held in a semi-cooled environment. In an embodiment, scale **700** may then weigh at least one pallet **150** and send this weight information to computer and/or PLC, which information may then be outputted to local storage and/or cloud-based databases described herein.

At least one pallet **150** may then be conveyed via conveyor system **130** described herein to first cooling station **300a** of second section **300** described herein. Chilled air in a temperature range of approximately 32 to 50 degrees may then be outputted onto the at least one pallet **150** to cool produce in the at least one pallet **150**.

In exemplary embodiments, blueberries within at the least one pallet **150** may be cooled to an optimal temperature of approximately 50 to 55 degrees.

As shown in **Figure 13A**, sensor feedback system **250**, including temperature sensors, may then start an RFID read process to determine temperature of produce within at least one pallet **150**. In this embodiment, an RFID reader antenna may read tags inserted/ placed within the at least one pallet **150** to determine current temperature of the produce within the at least one pallet **150**. In other embodiments, sensor feedback system **250** may utilize a Wi-Fi connection to wirelessly and continuously communicate information regarding produce from wireless temperature sensors to a PLC mounted in container **350**. In embodiments, temperature sensors may send temperature readings obtained from produce to the PLC, which PLC may then store and transmit this information locally to a computer connected to the PLC and mounted in container **350**. Computer may then output this temperature reading to a web address/user interface accessible by a user of a user computing device such as for e.g., a mobile device. Computer may also output this reading to local and/or cloud-based databases.

PLC may use this information received regarding the produce to determine whether to speed up the movement of the at least one pallet **150** containing produce on the conveyor system **130** or slow it down so that the produce will be cooled for a longer time frame. Although a user may directly control the AC unit to adjust the cooling temperature, the PLC may also determine if dampers described herein mounted in the container **350** should open and close to allow more or less air flow, as well as whether inline fans located outside the container **350** should spin faster or slower and thereby increase or decrease CFMs in system **100**. A user who wishes to change the temperature of the produce may monitor the webpage and turn the AC unit

down or up. In an exemplary embodiment, the goal/optimal temperature may be set through the web address/user interface, and the conveyors in conveyor system **130**, fans and/or dampers may be controlled by the PLC based on that goal regardless of the temperature of the AC unit.

5           If the temperature reading on the tags is not at an optimal level (an optimal level being, for e.g., blueberries at a temperature of approximately 50 to 55 degrees), then sensor feedback system **250** may wait a minute and repeat the process by continuing to read tags in the at least one pallet **150** via the RFID reader antenna to determine temperature of the produce. In embodiments, sensor feedback system **250**  
10 may continue to send the temperature information to local storage and/or cloud-based databases described herein.

          On the other hand, if the temperature reading on the tags is at the optimal level, then the at least one pallet **150** may then be transported to second cooling station **300b** described herein via the conveyor system **130**. See **Figure 13**. Chilled air  
15 in a temperature range of approximately 32 to 50 degrees may again be outputted onto the at least one pallet **150** to cool produce in the at least one pallet **150**. Temperature of produce within the at least one pallet **150** in the second section **300** may then be re-determined/evaluated via the steps of the sensor feedback system **250** described herein. See **Figure 13A**. Sensor feedback system **250** may then resend the  
20 temperature information to local storage and/or cloud-based databases described herein.

          At least one pallet **150** may then be transported to third cooling station **300c** described herein via the conveyor system **130**. Chilled air in a temperature range of approximately 32 to 50 degrees may then be outputted onto the at least one pallet **150**  
25 to cool produce in the at least one pallet **150**. Temperature of produce within the at

least one pallet **150** in the third section **400** may then be re-determined/evaluated via the sensor feedback system **250** described herein. See **Figure 12A**. Sensor feedback system **250** may then resend the temperature information to local storage and/or cloud-based databases described herein.

5           At least one pallet **150** may then be conveyed from the second section **300** onto a third section **400** via the conveyor system **130**. Third section **400** may maintain the chilled produce in the at least one pallet **150** at the optimal temperature prior to unloading.

Embodiments provide a method for cooling produce. Methods may include  
10   using the cooling systems **100**, **1000** described herein, including container **350**, conveyor system **130**, and sensor feedback system **250**. In an exemplary embodiment, the method includes inserting at least one pallet **150** containing produce into the particular embodiment of cooling systems **100**, **1000**. In some embodiments, the weight of the at least one pallet **150** may be measured and tracked via scale **700** of  
15   sensor feedback system **250**. The method includes transporting the produce in the at least one pallet **150** from the first section **200** of the container **350** to the second section **300** of the container **350** via the conveyor system **130**. The method includes cooling the produce within the at least one pallet **150** to an optimal temperature via internal-external cooling mechanism **500** and/or internal cooling mechanism **600**  
20   described herein installed within the second section **300**, continuously measuring and tracking the temperature of the produce within the at least one pallet **150** via the sensor feedback system **250** while the at least one pallet **150** is conveyed along the second section **300** to ensure the produce remains at the optimal temperature; and transporting the at least one pallet **150** from the second section **300** to the third section

400 via the conveyor system 130 for maintaining the produce at the optimal temperature prior to unloading.

## Harvest-to-Sale Data Collection Systems

Special harvest-to-sale data collection systems 1001, 1001A will now be  
5 described. It is an objective of these systems 1001 to provide data collection and  
usage solutions that will increase visibility and logistical support for all players in the  
supply chain, including farmer, packer, marketer, wholesaler, retailer, and consumer,  
which increases market efficiencies. The systems are configured to use the produce  
data for material requirements planning (MRP), particularly in certain stages, such as  
10 packing. It is also an objective of the systems to provide enhanced data collection and  
presentation about the “cold chain” to all participants in the “cold chain” of produce,  
including consumers at the end of the process. A cold chain is a temperature-  
controlled supply chain. An unbroken cold chain is an uninterrupted series of  
refrigerated production, storage and distribution activities, along with associated  
15 equipment and logistics, which maintain a desired low-temperature range. Under  
conventional produce systems, available cold chain data is segregated within  
particular participants, such as farms, pack houses, grocery wholesalers, and grocery  
retailers. As a result, comprehensive cold chain data is not available to all participants.  
Additionally, cold chain data is not available to end consumers of the produce. It is an  
20 object of the invention to provide integrated systems that collect and provide relevant  
cold chain data to all market participants, including end consumers, from the point of  
harvest to the point of sale.

The robust real-time data collection processes described herein provide the  
basis for an application service provider (ASP) application specific to produce data.

By collecting and uploading harvest-to-sale data into an ASP app, the system **1001**, **1001A** is able to control and profit from the data. Different players in the supply chain and cold chain are able to mine and parse the produce specific data to support their specific needs. For example, packers use weight and volume data to staff and supply  
5 the packing operation; marketers use other aspects of the data to advertise to and connect with potential buyers; wholesalers and grocery stores make purchase decisions based on factors such as source, produce variety, cold chain integrity, and volume; and end consumers use cold chain data to verify that they are buying a quality product.

10 The ASP app provides market participants with access to the data over a network, such over through a standard HTTP protocol. Different users can be provided with different levels of access through the ASP app, such as access to all or some subsets of data, access to write or to read-only, or ability to download or manipulate selected data. Pricing can be based on accessibility level, amount of usage,  
15 or other factors. The ASP app can provide specialized and powerful analytics functions to small-to-medium sized businesses that would otherwise not have access to such information. An ASP app reduces the cost of distributing software, and allows for enhanced features such as security, system wide software updates, and technical support to users.

20 It should be appreciated that these harvest-to-sale data collection systems **1001**, **1001A** can be used independently of the previously described cooling systems **100**, **1000**. However, as will be discussed below, the cooling systems **100**, **1000** described herein can be incorporated into certain steps of the harvest-to-sale systems **1001** to enhance the quality of the produce or provide automatic data collection, and  
25 thus improve both the quality and quantity of the data used in the systems **1001**.



## Independent Remote Packer Model

**Figure 18** presents a schematic flow of processes in what can be referred to as an independent remote packer model system **1001**. As indicated above, this system can be provided in the form of an ASP app. In the independent remote packer model  
5 **1001**, produce **152** is being acquired from a third party that is not directly linked into a data collection system. As will be discussed below, the system **1001** provides means for loading produce data into the system **1001** for future use. The system **1001** saves the data to a database in the cloud **2000** for use in marketing and selling produce **152** to wholesalers, retailers and end consumers.

10 As shown in **Figure 18A**, the produce **152**, such as blue berries, is harvested **1002** using known harvesting methods. Once the produce **152** has been harvested, it is brought to a selected loading destination **1004**. While in the loading destination **1004**, initial data is collected. At this point in the process, the data is likely to consist of weight and incoming produce temperature, but other data, such as ambient air  
15 temperature, humidity, date, time of day, farm of origin, variety, field location/block location, local weather conditions, and the like could also be collected.

If the produce **152** is loaded to a conventional loading destination **1021**, data about the produce is entered manually into the system **1022**. Manual data entry can be done using a conventional input means on a computer or mobile device, such as a  
20 keyboard or keypad. User friendly screens and prompts can be programmed into the system. However, if the produce **152** is loaded to a specialized data collection cooling system **100, 1000**, such as the mobile field cooling system described herein, the produce specific data is automatically collected by the various sensors previously described herein. The produce specific data is collected in digital form and the system  
25 **1001** is programmed to automatically pull the digital data into the system **1001**, as

indicated in step **1012**. Hybrids of manual and automatic collection can be provided, such as options for manually selecting which data sets will be automatically pulled into the system **1001**.

Data can be corrected manually in the system, such as at the pack house, where the fruit is sorted and graded, or anywhere else in the system where data updates or corrections are needed. Once the initial produce data has been collected, it is uploaded to a database **1030**. While different forms of databases could be used, current technology makes a database in the cloud **2000** particularly efficient and well-suited for the system **1001**. For example, system **1001** software interface in the form of a program or application (“app”) for a smart phone, tablet, or other computer can be downloaded by the independent harvester. In most applications, it is anticipated that data will be made available through the Internet, such as in an interactive ASP application, as discussed above. Once the initial produce data **1030** is in the system **1001**, the app interfaces with the system **1001** to upload the data **1030** to the database **2001** in the cloud **2000** for future use. While proprietary systems could be used for data collection, such as private satellite transmission, such systems are likely to be expensive and complicated compared to use of the cloud **2000**. Appropriate security protections are integrated into the system **1001** to eliminate or reduce the risk of hacking and misappropriation of produce data.

Once data **1030** transmission is complete, the produce **152** is transported to a pack house **1100**. Transportation will ordinarily start with a truck used to transport produce from the field, but may involve other means of transport, such as trains or boats, prior to reaching the pack house. The precise vehicle is not determinative, although the vehicle or vehicles will ideally be refrigerated. However, the system is ideally equipped to track the produce during transport to the pack house **1100**, since a

primary objective of the system is to track produce specific data all the way from the farm to the grocer. For example, the system **1001** ideally tracks at least the temperature of the vehicle during transport, in order to verify that produce **152** was maintained at an acceptable temperature throughout transport **1110**. The system **1001**  
5 can also track location (GPS), humidity and the like **1110**. Data can be time stamped so that an up-to-the-second record is available about the condition of the produce **152** at all times.

Alternatively, at step **1100**, produce **152** is sometimes transported directly to the grocer in an unpackaged state for packaging, in which case the process essentially  
10 skips to step **1310**, below. At other times, produce is individually packaged for the grocer at the harvest location and then sent directly to the grocer for check-in and sale, in which case the process essentially skips to step **1460**. These two options are currently less widely used. When these options are used, produce specific data will ideally be collected continuously in real-time in order to preserve a full data set for  
15 the grocer and end consumer, as well as any other interested parties.

Upon arrival of the produce **152** at the pack house **1130**, the data on the load of produce **152** is downloaded and “checked in” to the packer **1150**. The packer verifies and accepts the load, or modifies the weight **1200** if a change is noted. The system can be configured to print out appropriate transfer documents **1220**.

20 The data is used at this point to stage and supply the pack lines **1240**. The data can help schedule the labor, the delivery, and the quantity of packing supplies at the packing location. The system can be configured to provide full-blown MRP (material planning requirements) support. Kanban and other manufacture planning tools can be incorporated into the system. The produce **152** is packed into produce containers **1250**  
25 for subsequent sale.

Optionally, the price can be set when the produce is logged-in from the field, based on historical information about yield. By setting price at the moment of harvest, the producer gains control of the market. During the harvest, pack house intake, or packing stages, the produce specific data can be used by a marketer, such as an in-house marketer or marketing agent of the pack house, to market and sell the produce **152** to potential customers **1500**. At this stage, the potential customers are likely to be bulk buyers, such as wholesalers or grocery stores. By making the produce data available to potential buyers, market opportunities are expanded or created. Buyers are able to access criteria such as weight and temperature from the time of harvest, providing quantitative basis for assessing the product **152** and comparing it to other purchase options, including competitor produce for which harvest and transport data are unknown. It is anticipated that higher prices will typically be attached to higher quality harvest and transport conditions. Providing information about how much produce is in the system on a real-time basis makes the market efficient. Currently, quantity data is not widely available in the US, and is often data from the previous year, which is unreliable and thus may cause inefficient market decisions. With quantity visible in the system, the marketer can make better decisions on pricing. The system can also act as a business-to-business platform for bidding on produce, replacing or augmenting a bidding system that currently takes place predominately by phone. Additionally, all participants have access to real-time feedback. For example, by simply logging into the system **1001**, a farmer will know the disposition of his crop in real-time.

As indicated in **Figure 18C**, during the process of packing the produce **152** into containers, additional data is collected **1260**, such as weight and percentage of good fruit. Additionally, the system can be configured to automatically calculate

produce volume based on produce weight **1270**. The data is stacked in the system for use in making comparisons between data sets.

Marketers can view the current produce data **1510** from the database **2000** and use the data for marketing the produce **1520**. While user interface screens of the system **1001** can take various forms and configurations, it is anticipated that product specific information will generally be provided in the form of a market maker screen, where data about many shipments can be viewed and compared in the form of sortable, searchable tables and databases. Produce volume, as calculated in step **1270**, can be very useful at this stage for early marketing of the produce. The volume data provides a much earlier signal than would typically be available for demonstrating that the fruit is ready for sale. Other data can also be collected and provided to the marketer at this stage, such as place of origin, quality, and variety/strain.

Turning to **Figure 18D**, after the foregoing packaging and data processing steps, the produce is ready for delivery to a buyer, such a wholesaler or retailer, or, if a buyer has not been secured, to warehouse storage. The packaged produce is loaded on a transport vehicle **1300**, such as a refrigerated truck, where data can be collected during transport as previously described. The packaged produce **152** is delivered to a holding area **1320**. The system **1001** collects data in the holding area **1330**. The holding area data is uploaded **1330** to the database **2000**. The data will typically include at least weight and temperature, and may include positioning/GPS, humidity, time, date, identity of the party who took possession, and other useful information. The large amounts of data that are in the system provide a big data capability for users of the system, improving the efficiency of the market.

At an appropriate point during entry of produce into the retail stage, the system **1001** can be configured to create shipping documents **1350**. The shipping

documents can be printable or can be virtual in the system, i.e. remain in electronic and electronically accessible format. Shipping and related documentation can tie into government shipping regulators, such as the Department of Transportation. The system pulls relevant data into the shipping documents, thus eliminating manual steps.

5           **Figure 18E** summarizes steps in the retail stage of the system **1001**. At this stage, the buyer is likely a grocery distribution warehouse, where the produce will be repackaged for delivery to grocery stores and individual sale to consumers. The system is configured to check the produce in at the buyer/retailer **1400**, thus eliminating manual steps. After the produce is formally checked in, the system is  
10 configured to download the produce data from the database **2000** to the buyer's data system **1410**, which will often be a real-time system. A large grocery wholesale will typically license specialized software from a large software provider, such as SAP. The system **1001** is configured to interact with such third-party systems in order to deliver produce data to the buyer **1410**.

15           The produce is packed into consumer sized packages, such as private labeled packages, for retail sale **1430**. The system **1001** can be configured to provide data for review by the consumer at the point-of-sale **1460**. The consumer sized packages of produce are stocked in a retail store, such as a conventional grocery store. Consumers view the produce, and have the option of viewing the displayed produce data **1480**.  
20 The produce data can be provided to the consumer in the form of printed material, such as labels applied to individual packaging, or in the form of a display about a segregated shipment of produce. In some embodiments, the produce data is provided in electronic format. For example, in some embodiments, the consumer uses a smart phone to scan a QR code, an RFID tag, a modifiable RFID tag, or analogous feedback

means that prompts download of specific produce data to the consumer's phone. In a successful interaction, the consumer selects the product for purchase **1490**.

### **Farm-based Pack House Model**

With reference to **Figure 19**, embodiments of a farm-based pack house model system **1001A** for data collection and use will now be described. As indicated above, this system can be provided in the form of an ASP app. In these models, the farm and the pack house are integrated. As such, the farm does not operate independently of the data collection system, unlike in the independent remote packer model **1001** discussed above. As will be seen, there is considerable overlap between the two systems, but the farm-based pack house model allows for the elimination of several steps found in the independent remote packer model system **1001**, as well as options for internal data storage.

As shown in **Figure 19A**, the produce **152**, such as blue berries, is harvested **1002** using known harvesting methods. Once the produce **152** has been harvested, it is brought to a selected loading destination **1004**. While in the loading destination **1004**, initial data is collected. At this point in the process, the data is likely to consist merely of weight and incoming produce temperature, but other data, such as ambient air temperature, humidity, date, time of day, farm of origin, produce variety, field location/block location, local weather conditions, and the like could also be collected.

If the produce **152** is loaded to a conventional loading destination **1021**, data about the produce is entered manually into the system **1022**. Manual data entry can be done using a conventional computer or mobile device, as described above. However, if the produce **152** is loaded to a specialized data collection cooling system **100, 1000**, such as the mobile field cooling system described herein, the produce data is automatically collected by the various sensors previously described herein. The

produce specific data is collected in digital form and the system **1001** is programmed to automatically pull the digital data into the system **1001**, as indicated in step **1012**. Hybrids of manual and automatic collection can be provided, such as options for manually selecting which data sets will be automatically pulled into the system **1001**.

5           Data can be corrected manually in the system, such as at the pack house, where the fruit is sorted and graded, or anywhere else in the system where data updates or corrections are needed. Once the initial produce data has been collected, it is uploaded to a database **1030**. In **Figure 19A**, the farm-based database is indicated with a generic database symbol **2000**. Since data is collected and used internally in the

10 farm-based system, use of a cloud based database is not required. For example, it might be desirable to use a proprietary in-house database **2000**, such as on a stand-alone server or a server bank. Use of an in-house server enhances control of the system (for example, in troubleshooting technical difficulties and updating software), reduces system complexity by eliminating or reducing web interfaces, and can

15 eliminate the risk of third-party hacking of data. The option of using a cloud based database **2000** remains open, depending on the preference of the users of the system **1001A**. In most applications, it is anticipated that data, whether stored in the cloud or not, will be made available through the Internet, such as in an interactive ASP application, as discussed above. Optionally, produce data can be backed up for

20 security, such as to the cloud. As with the independent packer system **1001**, appropriate security protections are integrated into the system **1001A** to eliminate or reduce the risk of hacking and misappropriation of produce data.

In the farm-based system **1001A**, the produce is already in the possession of the farm that will carry out the packing operations, so the foregoing steps of delivery

25 to the pack house are not used, other than transporting the produce to the packing



station at or affiliated with the farm. The data is used at this point to stage and supply the pack lines **1240**. The data can help schedule the labor, the delivery, and the quantity of packing supplies at the packing location. The system can be configured to provide full-blown MRP (material planning requirements) support. Kanban and other  
5 manufacture planning tools can be incorporated into the system. The produce **152** is packed into produce containers **1250** for subsequent sale.

As with the independent pack model system **1001**, after step **1030**, produce **152** harvested in the farm-based system **1001A** is sometimes transported directly to the grocer in an unpackaged state for packaging, in which case the process essentially  
10 skips to step **1310**, below. At other times, produce is individually packaged for the grocer at the harvest location and then sent directly to the grocer for check-in and sale, in which case the process essentially skips to step **1460**. As noted above, these two options are currently less widely used. When these options are used, produce specific data will ideally be collected continuously in real-time in order to preserve a full data  
15 set for the grocer and end consumer, as well as any other interested parties.

As noted above, optionally, the price can be set when the produce is logged-in from the field, based on historical information about yield. By setting price at the moment of harvest, the producer gains control of the market. During the harvest or packing stage, the produce specific data can be used by a marketer, such as an in-  
20 house marketer or marketing agent of the pack house, to market and sell the produce **152** to potential customers **1500**. As noted above, at this stage, the potential customers are likely to be bulk buyers, such as wholesalers or grocery stores. By making the produce data available to potential buyers, market opportunities are expanded or created. Buyers are able to access criteria such as weight and temperature from the  
25 time of harvest, providing quantitative basis for assessing the product **152** and

comparing it to other purchase options, including competitor produce for which harvest and transport data are unknown. It is anticipated that higher prices will typically be attached to higher quality harvest and transport conditions. As discussed above, the system enables various market efficiencies in the marketing and sale of  
5 produce.

As indicated in **Figure 19C**, during the process of packing the produce **152** into containers, additional data is collected **1260**, such as weight and percentage of good fruit. Additionally, the system can be configured to automatically calculate produce volume based on produce weight **1270**. As noted above, the data is stacked in  
10 the system.

Marketers can view the current produce data **1510** from the database **2000** and use the data for marketing the produce **1520**, using interface screens and functions as described above. Produce volume, as calculated in step **1270**, can be very useful at this stage for early marketing of the produce. The volume data provides a much  
15 earlier signal than would typically be available for demonstrating that the fruit is ready for sale. Other data can also be collected and provided to the marketer at this stage, such as place of origin, quality, and variety/strain.

Turning to **Figure 19D**, after the foregoing packaging and data processing steps, the produce is ready for delivery to a buyer, such a wholesaler or retailer, or, if  
20 a buyer has not been secured, to warehouse storage. The packaged produce is loaded on a transport vehicle **1300**, such as a refrigerated truck, where data can be collected during transport as previously described. The packaged produce **152** is delivered to a holding area **1320**. The system **1001A** collects data in the holding area **1330**. The holding area data is uploaded **1330** to the database **2000**. The data will typically  
25 include at least weight and temperature, and may include positioning/GPS, humidity,

time, date, identity of party who took possession, and other useful information. As noted above, the large amounts of data that are in the system provide a big data capability for users of the system, improving the efficiency of the market.

At an appropriate point during entry of produce into the retail stage, the system **1001A** can be configured to create shipping documents **1350**. As noted above, the shipping documents can be provided in virtual format. The system pulls relevant data into the shipping documents, thus eliminating manual steps.

**Figure 19E** summarizes steps in the retail stage of the system **1001A**. At this stage, the buyer is likely a grocery distribution warehouse, where the produce will be repackaged for delivery to grocery stores and individual sale to consumers. The system is configured to check the produce in at the buyer/retailer **1400**, thus eliminating manual steps. After the produce is formally checked in, the system is configured to download the produce data from the database **2000** to the buyer's data system **1410**, which may be a real-time system. A large grocery wholesale will typically license specialized software from a large software provider, such as SAP. The system **1001A** is configured to interact with such third-party systems in order to deliver produce data to the buyer **1410**.

The produce is packed into consumer sized packages, such as private labeled packages, for retail sale **1430**. The system **1001A** can be configured to provide data for review by the consumer at the point-of-sale **1460**. The consumer sized packages of produce are stocked in a retail store, such as a conventional grocery store. Consumers view the produce, and have the option of viewing the displayed produce data. The produce data can be provided to the consumer in the form of printed material, such as labels applied to individual packaging, or in the form of a display about a segregated shipment of produce. In some embodiments, the produce data is provided in electronic

format. For example, in some embodiments, the consumer uses a smart phone to scan a QR code, an RFID tag, a modifiable RFID tag, or analogous feedback means that prompts download of specific produce data to the consumer's phone. In a successful interaction, the consumer selects the product for purchase **1490**.

5           As noted above, it is an objective of the systems **1001, 1001A** to provide enhanced data to all participants in the "cold chain" of produce, including consumers at the end of the process. Modifiable RFIDs and analogous technologies are available that both collect and transmit selected data. For example, some RFID tags have embedded thermometer software that collects temperature data. To further enhance  
10 data collection and supply, produce can be tagged with modifiable RFIDs or analogous technology when the fruit enters the system, such as at the point of harvest or at the start of the initial cool-down stage. The RFID tags collect data about the produce, such as location and the temperature, over time during the harvest-to-sale process, including the retail stage. In the retail stage, data might include produce  
15 temperatures while in the store, days since stocking in the store, origin, variety, all cold chain data (optionally in truncated form), and similar data of interest to end-purchasers. The grocer can configure the data report on the package label to meet competitive and governmental requirements. The collected data benefits all users of the system. The data tells marketers and consumers where fruit and vegetables have  
20 been and what the cold chain did to preserve freshness of the produce. For example, a smart phone can be programmed with an app that reads the produce information on a produce package in the grocery store. The produce information tells the consumer where the fruit came from, the journey it took, the players who interacted with the produce, and the history of the cold chain. Currently, for example, Groov® software  
25 can be used to display produce data provided by PLCs interfaced with sensors. By

providing systems **1001, 1001A** that record and display produce data about the entire cold chain of custody, consumers are assured that they are buying the freshest and longest lasting fruits and vegetables available on the market.

It will be appreciated that steps in the foregoing processes **1001, 1001A** can be  
5 modified, embellished upon, performed in alternate orders, or in some cases  
eliminated, without deviating from the spirit and scope of the invention.

While the embodiments are described with reference to various implementations and exploitations, it will be understood that these embodiments are  
10 illustrative and that the scope of the inventions is not limited to them. Many  
variations, modifications, additions, and improvements are possible. Further still, any  
steps described herein may be carried out in any desired order, and any desired steps  
may be added or deleted.

**WHAT IS CLAIMED IS:**

1. A system for cooling produce comprising:
  - a mobile container having an input opening on a first end and an output opening on an opposing end thereof, the input and output openings configured to receive produce containers therethrough,
  - the mobile container having
    - a staging section adjacent the input opening for receiving produce containers conveyed through the input opening, the staging section providing a cooled environment for initial cooling of produce,
    - a rapid cooling section having
      - a first cooling station positioned to receive produce containers conveyed from the staging section, the first cooling station having an associated cooling mechanism for cooling produce in the first cooling station,
      - a second cooling station positioned to receive produce containers conveyed from the first cooling station, the second cooling station having an associated cooling mechanism for cooling produce in the second cooling station, and
      - a third cooling station positioned to receive produce containers conveyed from the second cooling station, the third cooling station having an associated cooling mechanism for cooling produce in the third cooling station,
  - the first, second and third cooling stations together sequentially cooling produce to an optimal temperature by at least the third cooling station, and

a discharge section positioned to receive produce containers conveyed from the third cooling station of the rapid cooling section and maintain produce at the optimal temperature, the discharge station configured to convey produce containers out of the mobile container through the output opening, and

a sensor feedback system configured to continuously measure and track temperature of produce as produce containers are conveyed through the system.

2. The system of **claim 1**, further comprising a conveyor system in the mobile container for conveying produce containers from the input end to the output end to thereby sequentially transport produce containers through the staging, rapid cooling and discharge sections.
3. The system of **claim 2**, wherein the sensor feedback system is a dynamic real-time sensor feedback system, the sensor feedback system further configured to measure and track weight of produce as produce containers are conveyed through the system.
4. The system of **claim 2**, further comprising a plurality of doors, the doors positioned to selectively close and thereby retain cold air for circulation within each of the first cooling station, the second cooling station, and the third cooling station during cooling of produce.
5. The system of **claim 4**, wherein each of the plurality of doors is an automatic roll-up door.
6. The system of **claim 1**, wherein the cooling mechanism in the first, second, and third cooling stations includes chilled air outputted via cooling fans and coils located on a first side of each of the first, second, and third cooling stations to thereby

force chilled air over produce, with air being internally recirculated via return air ducts and fans located on an opposing second side of each of the first, second, and third cooling stations back to the cooling fans and coils located on the first side.

7. The system of **claim 3**, wherein the sensor feedback system includes at least a first sensor integrated with the conveyor system and used to measure weight of at least one pallet upon entering the system and a second sensor placed within the at least one pallet and used to measure the temperature of produce within the at least one pallet.

8. The system of **claim 7**, wherein the at least first and second sensors send at least one of weight and temperature information to a PLC device.

9. The system of **claim 8**, wherein the PLC device obtains at least the weight and temperature information of the produce and sends the weight and temperature information to at least one of local storage and a cloud-based database.

10. The system of **claim 3**, wherein the sensor feedback system includes sensors mounted within the mobile container that allow a user to determine the location of the at least one pallet in the cooling system.

11. The system of **claim 3**, wherein a PLC device is connected to and controls at least one of the cooling mechanism, conveyor system, and sensor feedback system.

12. A method for cooling produce, comprising:

inserting at least one pallet containing produce into a cooling system, wherein the cooling system includes

a mobile container including at least a separated first, second, and third section, wherein the first section holds the at least one pallet containing produce in a semi-cooled environment, wherein the second section includes a cooling mechanism



to cool the produce within the at least one pallet to an optimal temperature, wherein the third section includes the cooling mechanism to maintain cooled produce in the at least one pallet at the optimal temperature;

a conveyor system including at least one conveyor longitudinally extending along the length of the mobile container, the conveyor system used to convey the at least one pallet from the first section to each of the second and third sections; and

a sensor feedback system configured to continuously measure and track at least the weight of the at least one pallet and temperature of the produce within the at least one pallet as the at least one pallet is conveyed across the cooling system;

transporting the produce from the first section to the second section via the conveyor system;

cooling the produce within the at least one pallet to the optimal temperature via the cooling mechanism;

continuously measuring and tracking at least the weight and temperature of the produce within the at least one pallet via the sensor feedback system while conveying the at least one pallet along the second section to ensure the produce remains at the optimal temperature;

transporting the produce from the second section to the third section via the conveyor system; and

maintaining the produce within the at least one pallet at the optimal temperature.

13. The method of **claim 12**, wherein the second section includes a first cooling station, a second cooling station, and a third cooling station, each of which is configured to hold the at least one pallet being conveyed across the system.

14. The method of **claim 13**, wherein the cooling mechanism in the first, second, and third cooling stations includes chilled air outputted via vents located on a first side of the mobile container to cool produce in the at least one pallet, with heat from the produce being exhausted out via vents located on an opposing second side of the mobile container.

15. The method of **claim 13**, wherein the cooling mechanism in the first, second, and third cooling stations includes chilled air outputted via cooling fans and coils located on a first side of each of the first, second, and third cooling stations to cool produce in the at least one pallet, with heat from the produce being internally recirculated via return air ducts and fans located on an opposing second side of each of the first, second, and third cooling stations back to the cooling fans and coils located on the first side.

16. The method of **claim 12**, wherein the sensor feedback system includes at least a first sensor integrated with the conveyor system and used to measure weight of the at least one pallet upon entering the system and a second sensor placed within the at least one pallet and used to measure the temperature of the produce within the at least one pallet.

17. The method of **claim 12**, wherein the sensor feedback system includes sensors mounted within the mobile container that allow a user to determine the location of the at least one pallet in the cooling system.

18. A system, comprising:

a mobile container including a cooling mechanism, the mobile container having separated sections to continuously cool produce to, and maintain the produce at, an optimal temperature via the cooling mechanism;

a conveyor system to convey produce across the separated sections of the mobile container; and

a sensor feedback system to continuously measure, track, and store relevant information regarding the produce being conveyed across the mobile container, and to control the movement of the conveyor system based on this information.

**19.** The system of **claim 30**, wherein the cooling mechanism includes an external cooling mechanism that interacts with an internal cooling mechanism installed within the mobile container to cool the produce.

**20.** The system of **claim 30**, wherein the cooling mechanism is an entirely internal cooling mechanism installed within the mobile container.

**21.** A system for cooling produce comprising:

a mobile container having an input opening on a first end and an output opening on an opposing end thereof, the input and output openings configured to receive produce containers therethrough,

the mobile container having

a staging section adjacent the input opening for receiving produce containers conveyed through the input opening, the staging section providing a cooled environment for initial cooling of produce,

a rapid cooling section configured for cooling produce to an optimal temperature, and

a discharge section positioned to receive produce containers conveyed from the rapid cooling section and maintain produce at the optimal temperature, the discharge station configured to convey produce containers out of the mobile container through the output opening.

- 22.** The system of **claim 21**, wherein the a rapid cooling section comprises a first cooling station positioned to receive produce containers conveyed from the staging section, the first cooling station having an associated cooling mechanism for cooling produce in the first cooling station, a second cooling station positioned to receive produce containers conveyed from the first cooling station, the second cooling station having an associated cooling mechanism for cooling produce in the second cooling station, and a third cooling station positioned to receive produce containers conveyed from the second cooling station, the third cooling station having an associated cooling mechanism for cooling produce in the third cooling station, the first, second and third cooling stations together sequentially cooling produce to the optimal temperature by at least the third cooling station.
- 23.** The system of **claim 22**, further comprising a conveyor system in the mobile container for conveying produce containers from the input end to the output end to thereby sequentially transport produce containers through the staging, rapid cooling and discharge sections.
- 24.** The system of **claim 23**, further comprising a plurality of doors, the doors positioned to selectively close and thereby retain cold air for circulation within each of the first cooling station, the second cooling station, and the third cooling station during cooling of produce.

25. The system of **claim 24**, wherein the doors are automatic roll-up doors.
26. The system of **claim 21**, wherein the mobile container is fixed on a wheeled trailer chassis for use in moving the mobile container.
27. The system of **claim 21**, wherein the cooling mechanism in the first, second, and third cooling stations includes chilled air outputted via vents located on a first side of the mobile container to flow chilled air over produce and then into exhaust vents located on an opposing second side of the mobile container.
28. The system of **claim 21**, wherein the cooling mechanism in the first, second, and third cooling stations includes chilled air outputted via cooling fans and coils located on a first side of each of the first, second, and third cooling stations to thereby force chilled air over produce, with air being internally recirculated via return air ducts and fans located on an opposing second side of each of the first, second, and third cooling stations back to the cooling fans and coils located on the first side.
29. The system of **claim 21**, wherein the cooling mechanism in the third section includes chilled air outputted via vents located on opposing sides of the mobile container to thereby force chilled air over produce from opposing sides.
30. The system of **claim 22**, wherein the conveyor system includes at least seven conveyors extending along each of the first section, second section, and third section of the mobile container.

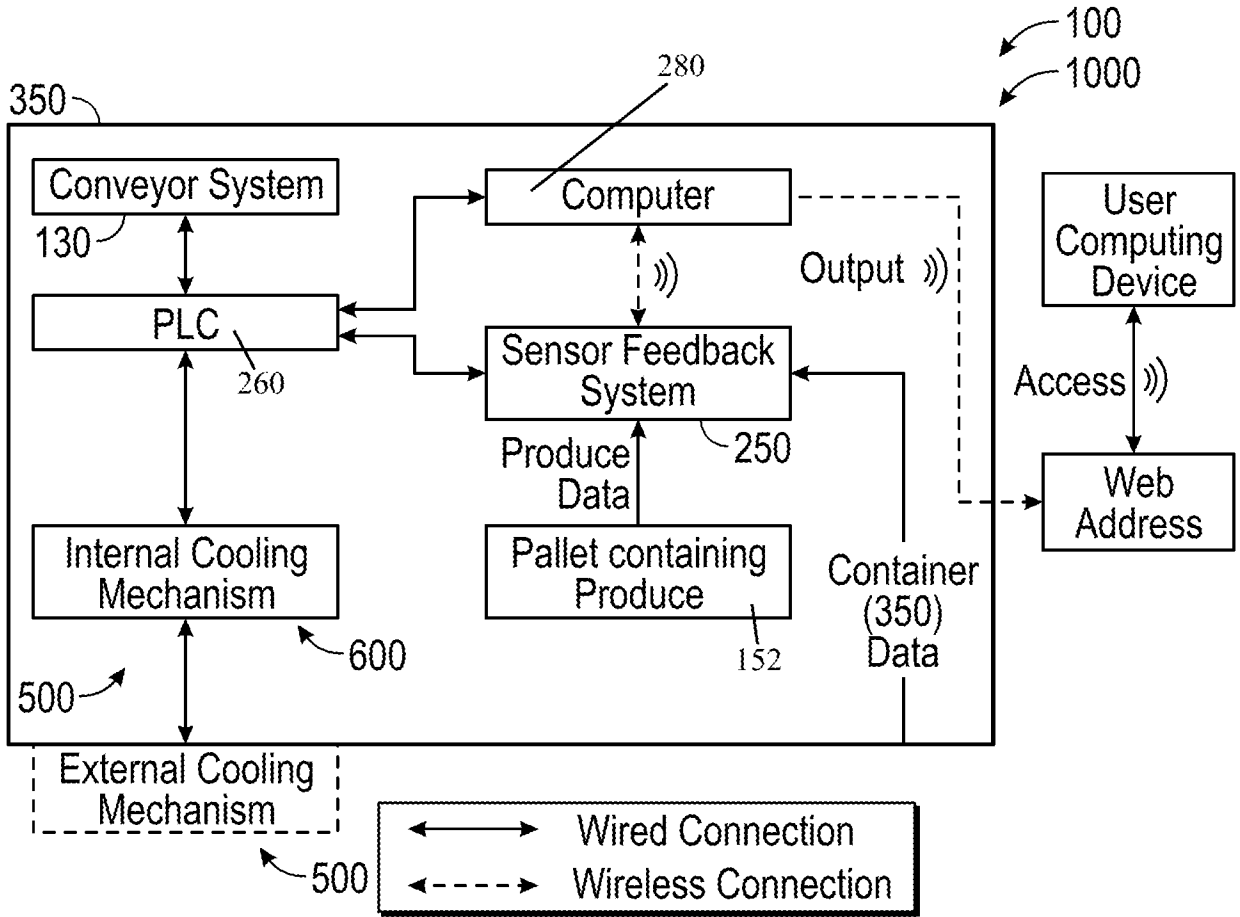

FIG. 1

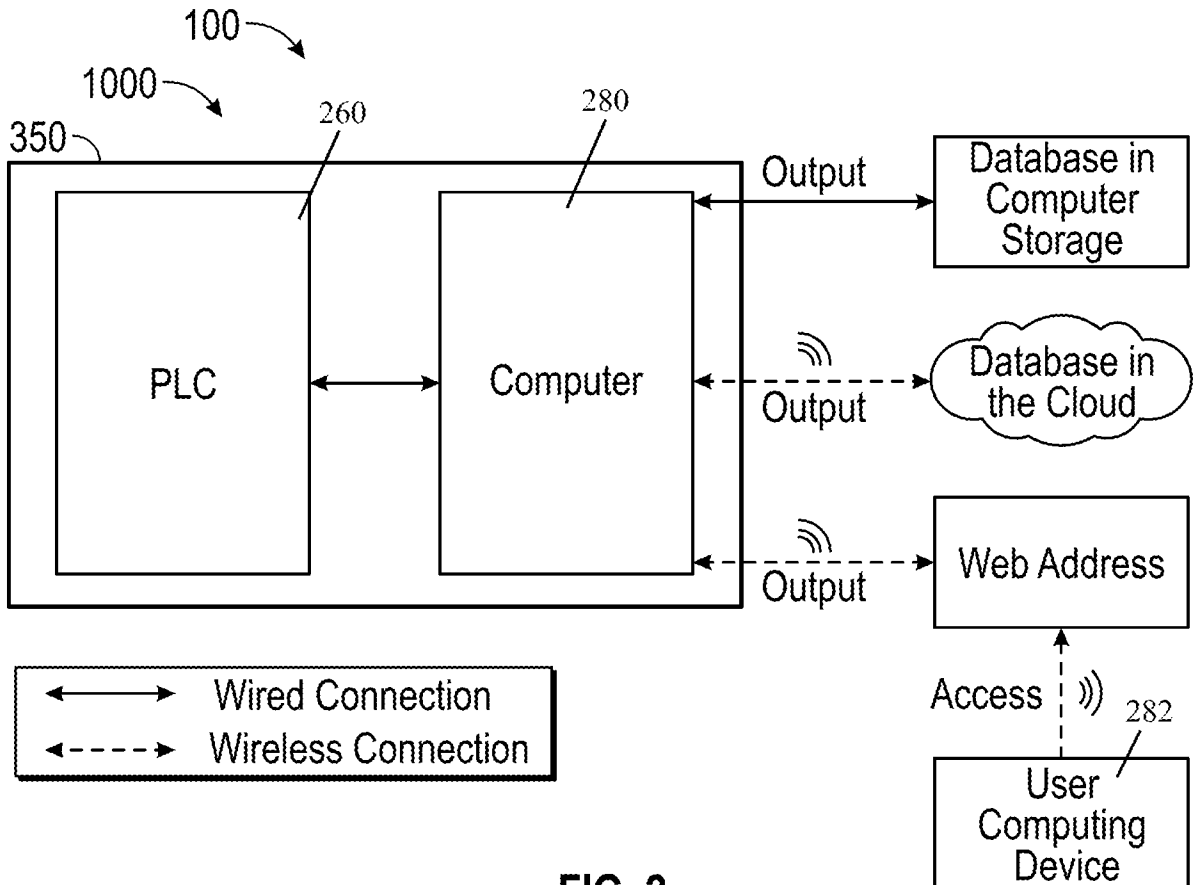

FIG. 2

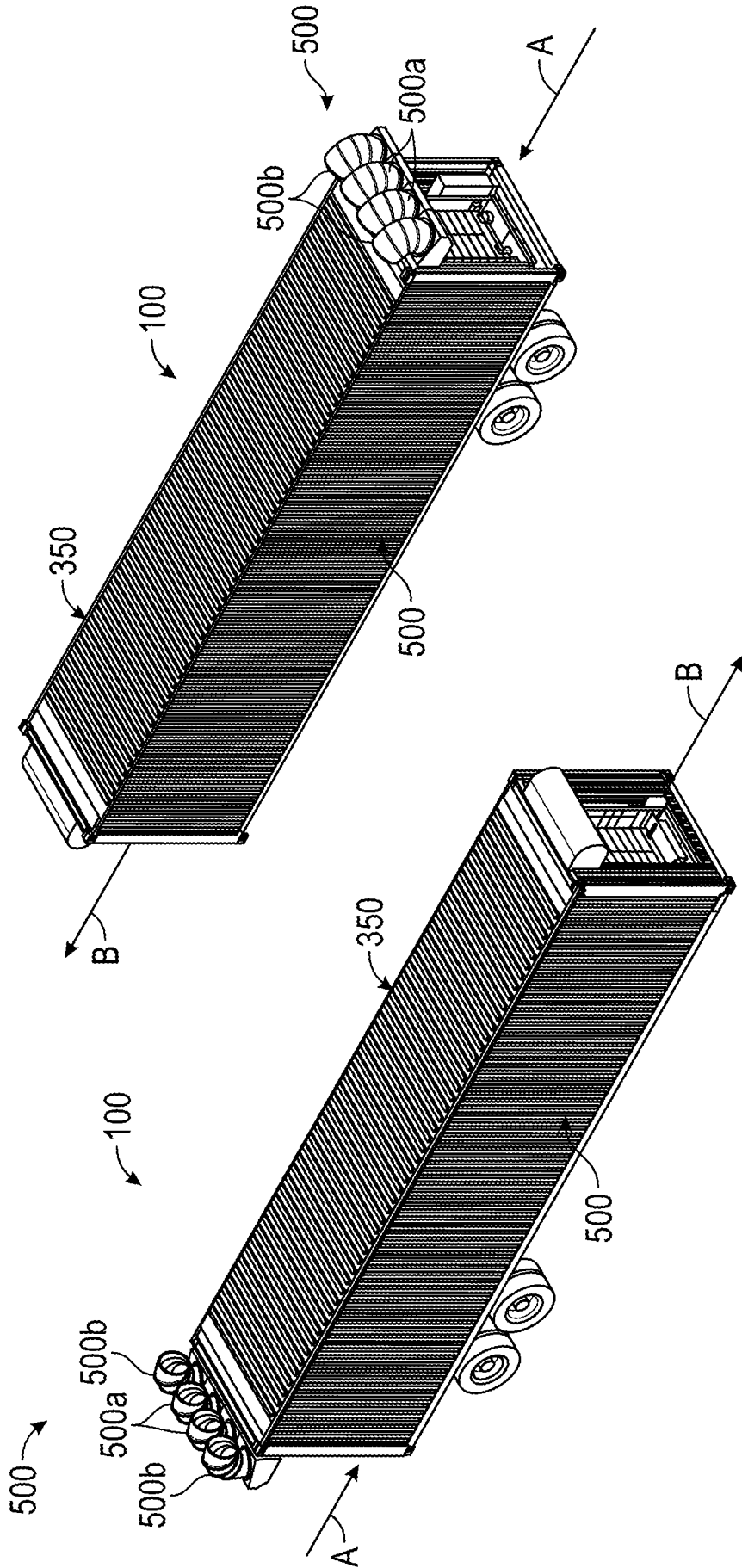

FIG. 3B

FIG. 3A

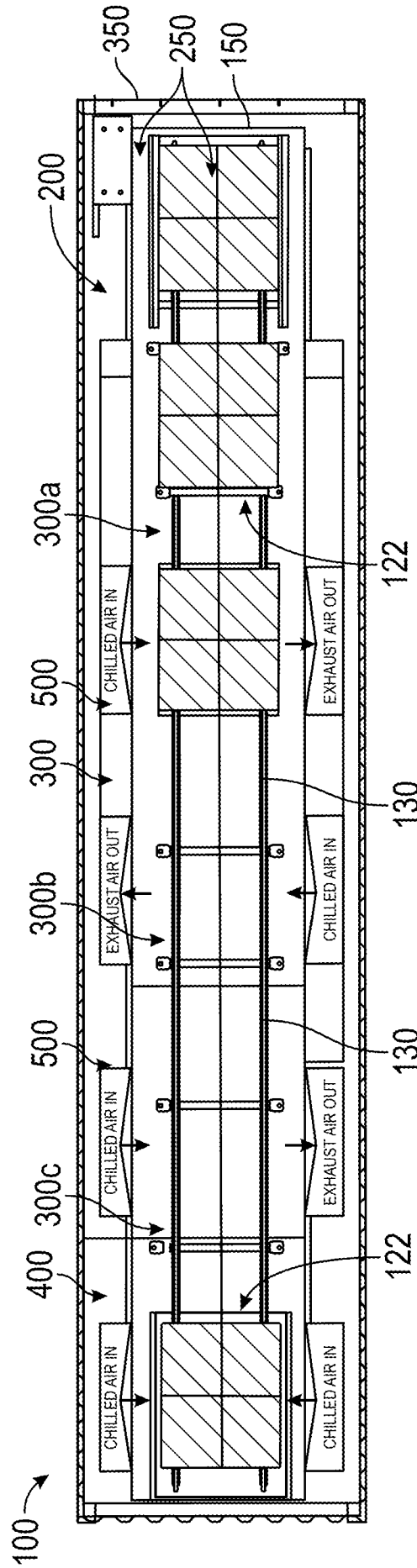

FIG. 4



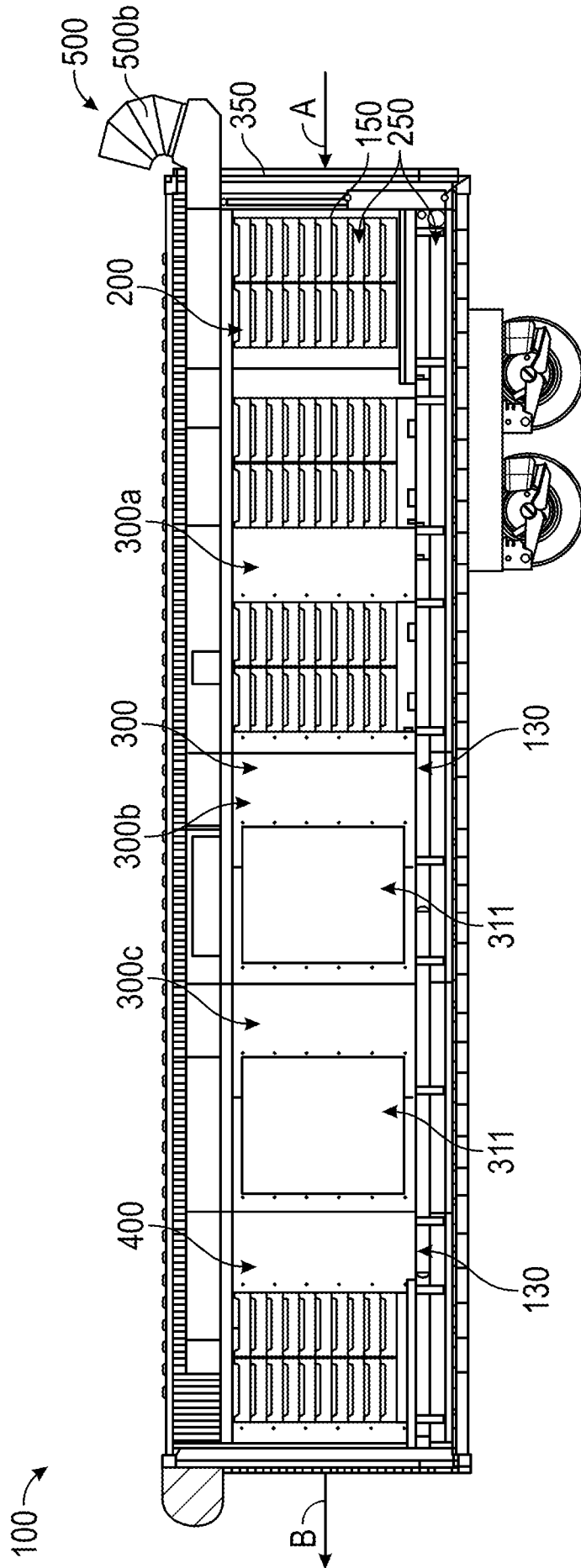

FIG. 5

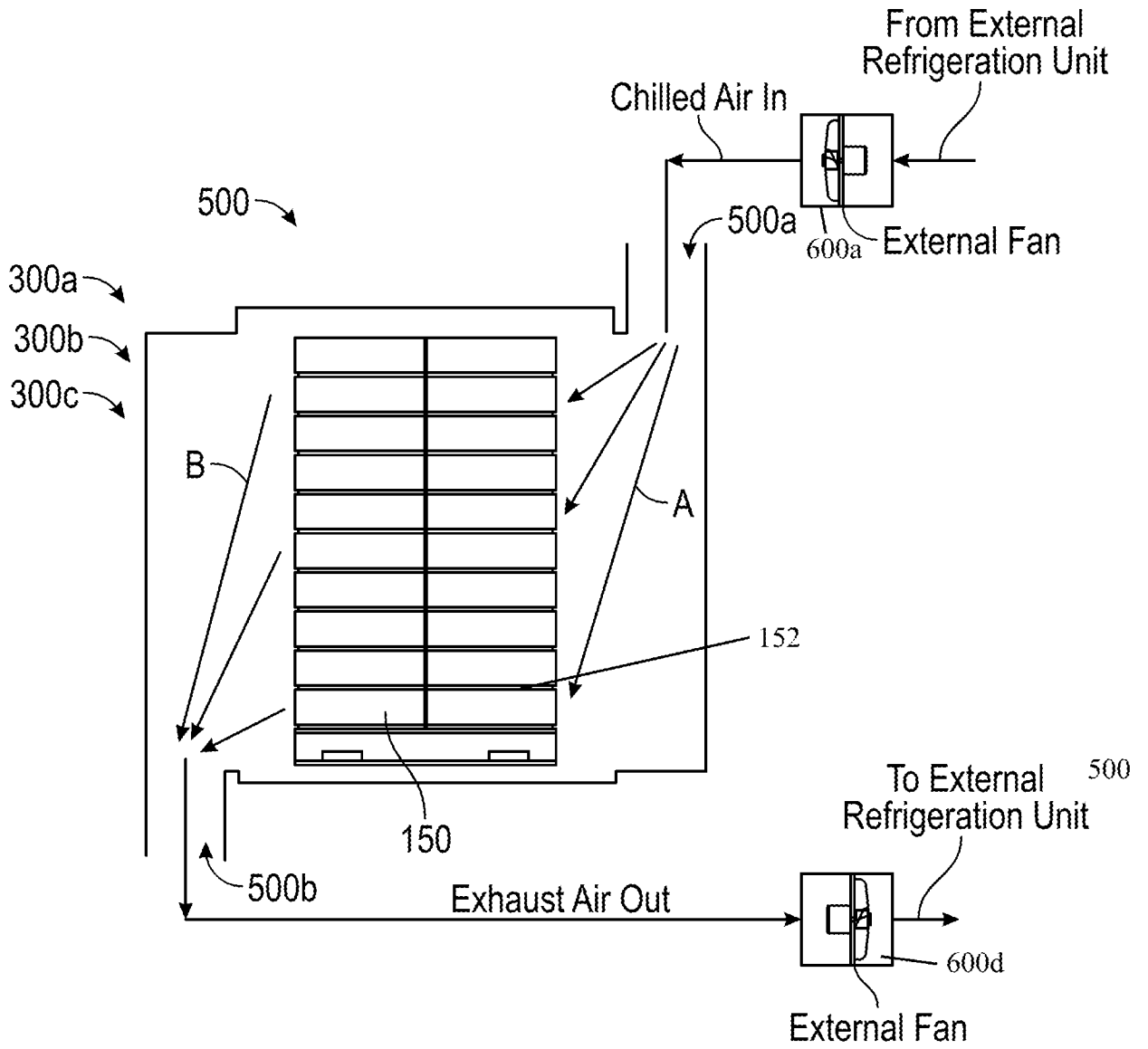

FIG. 6

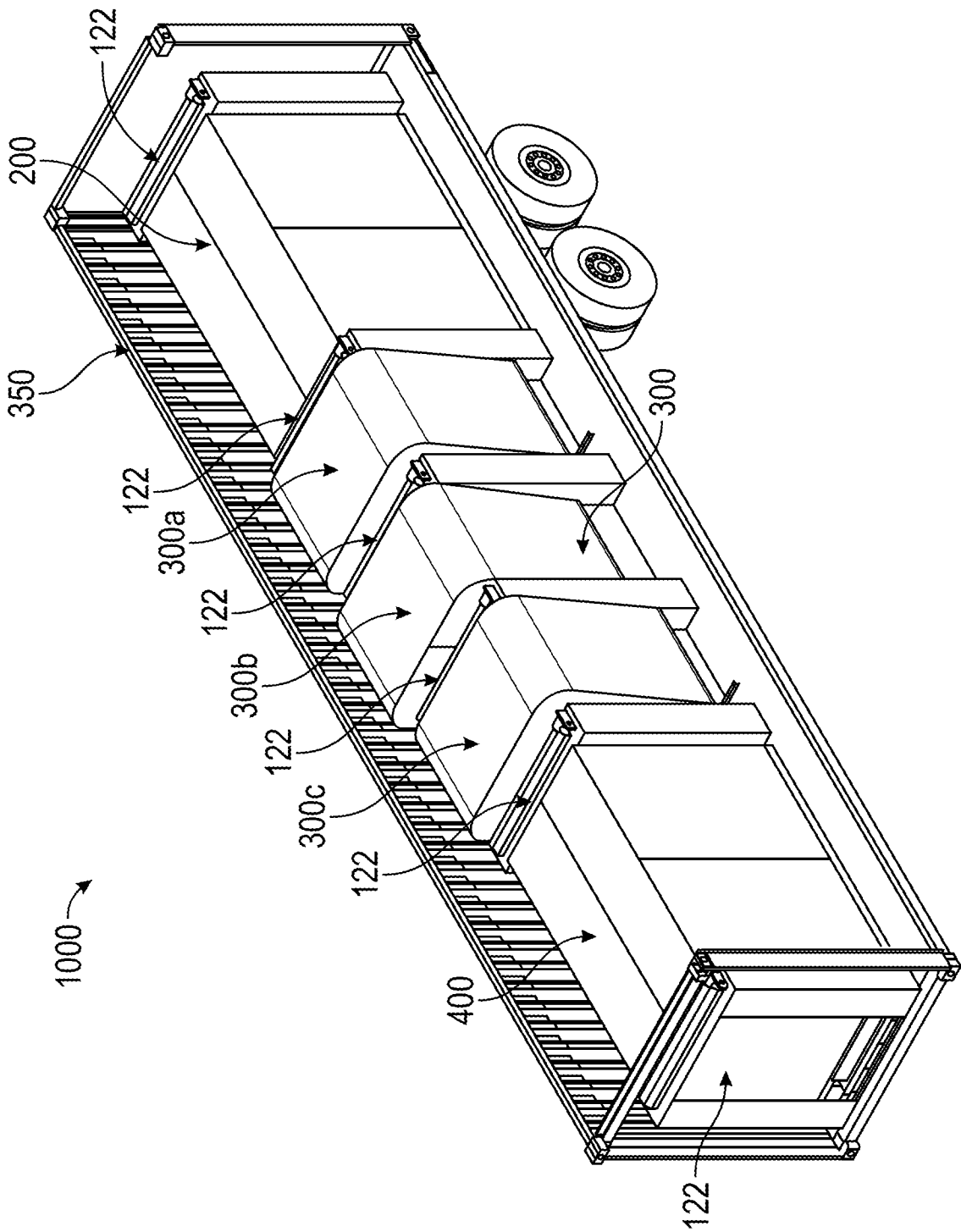

FIG. 7

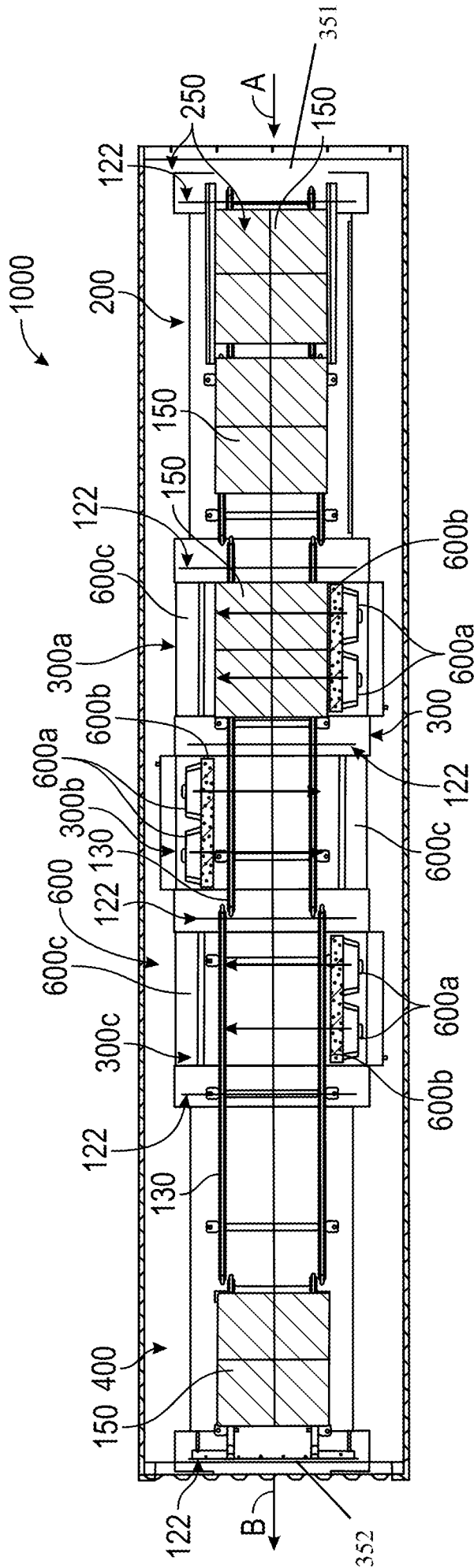

FIG. 8

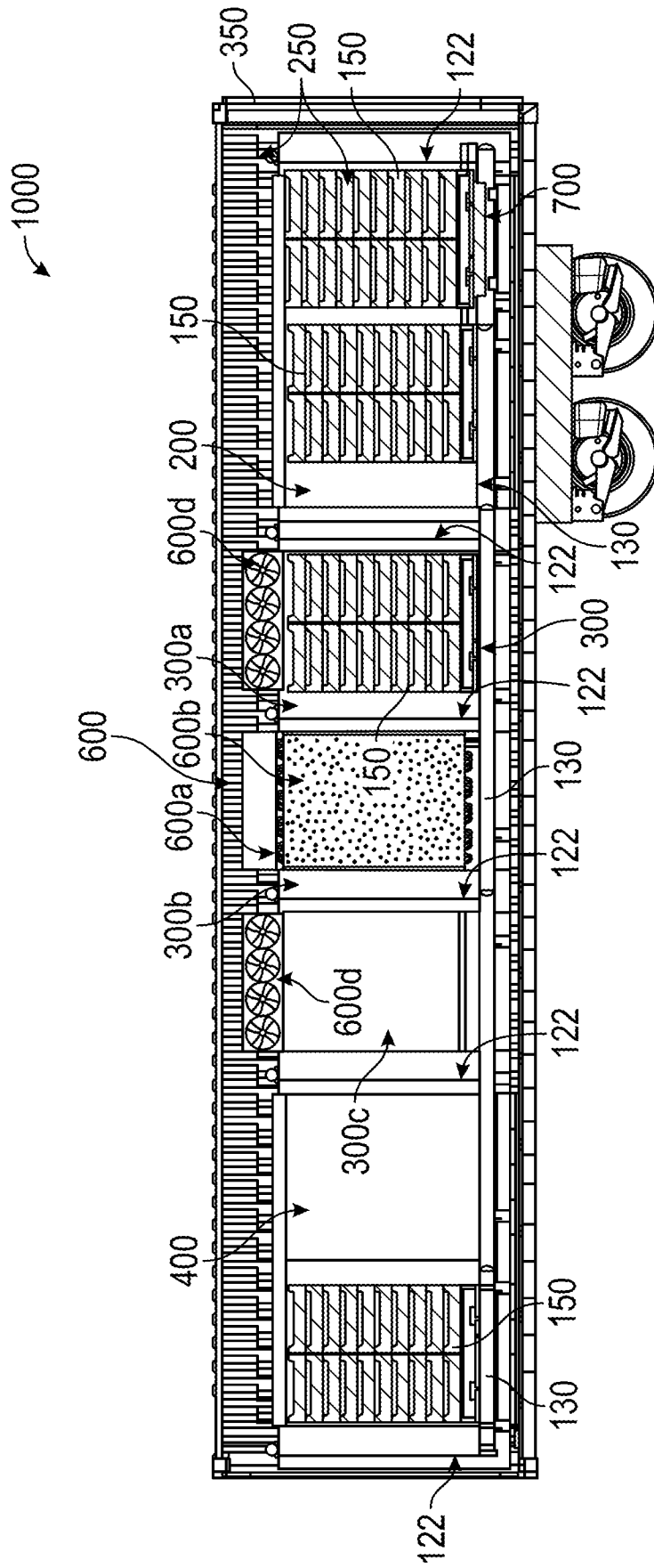

FIG. 9

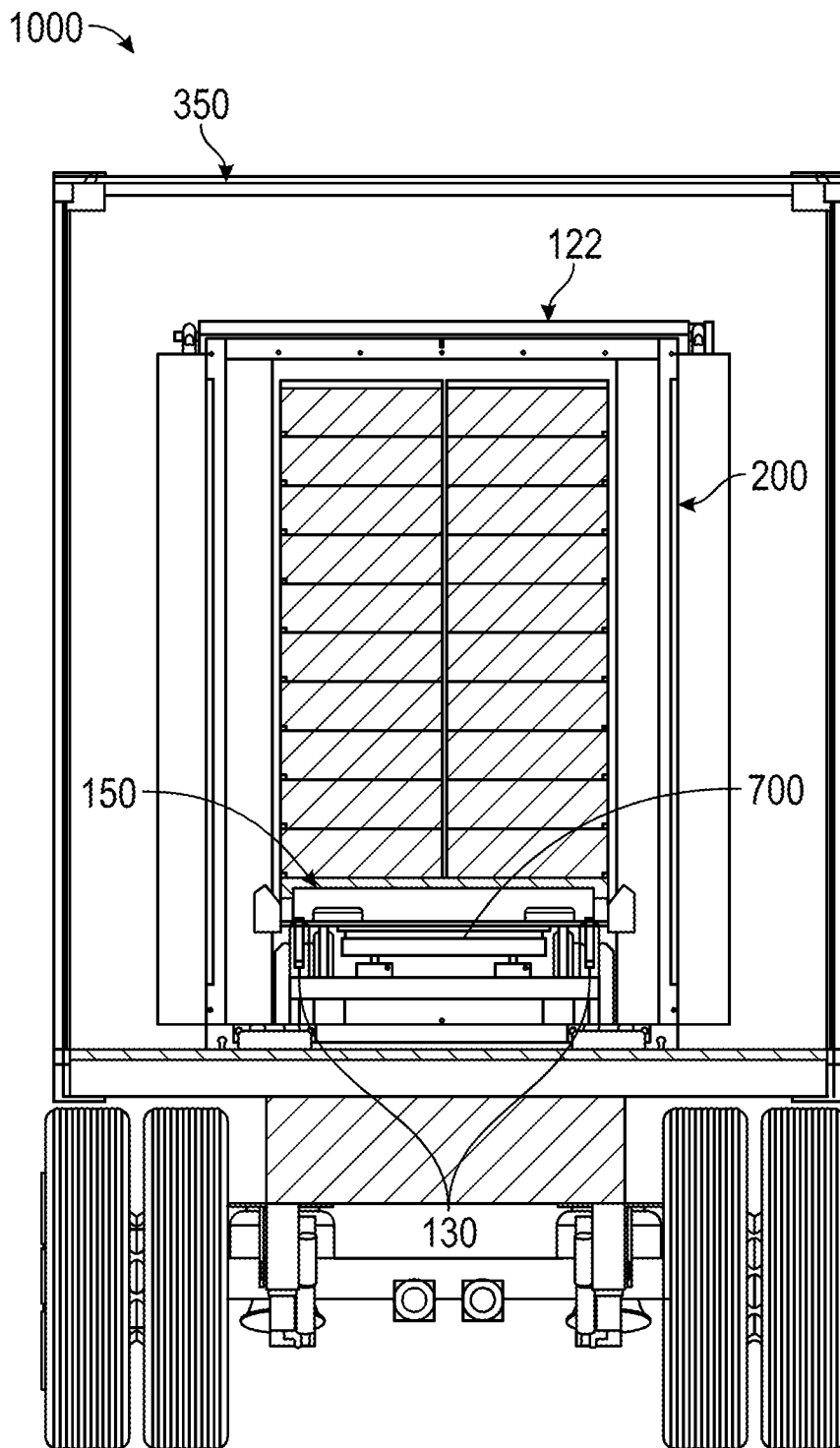

FIG. 10

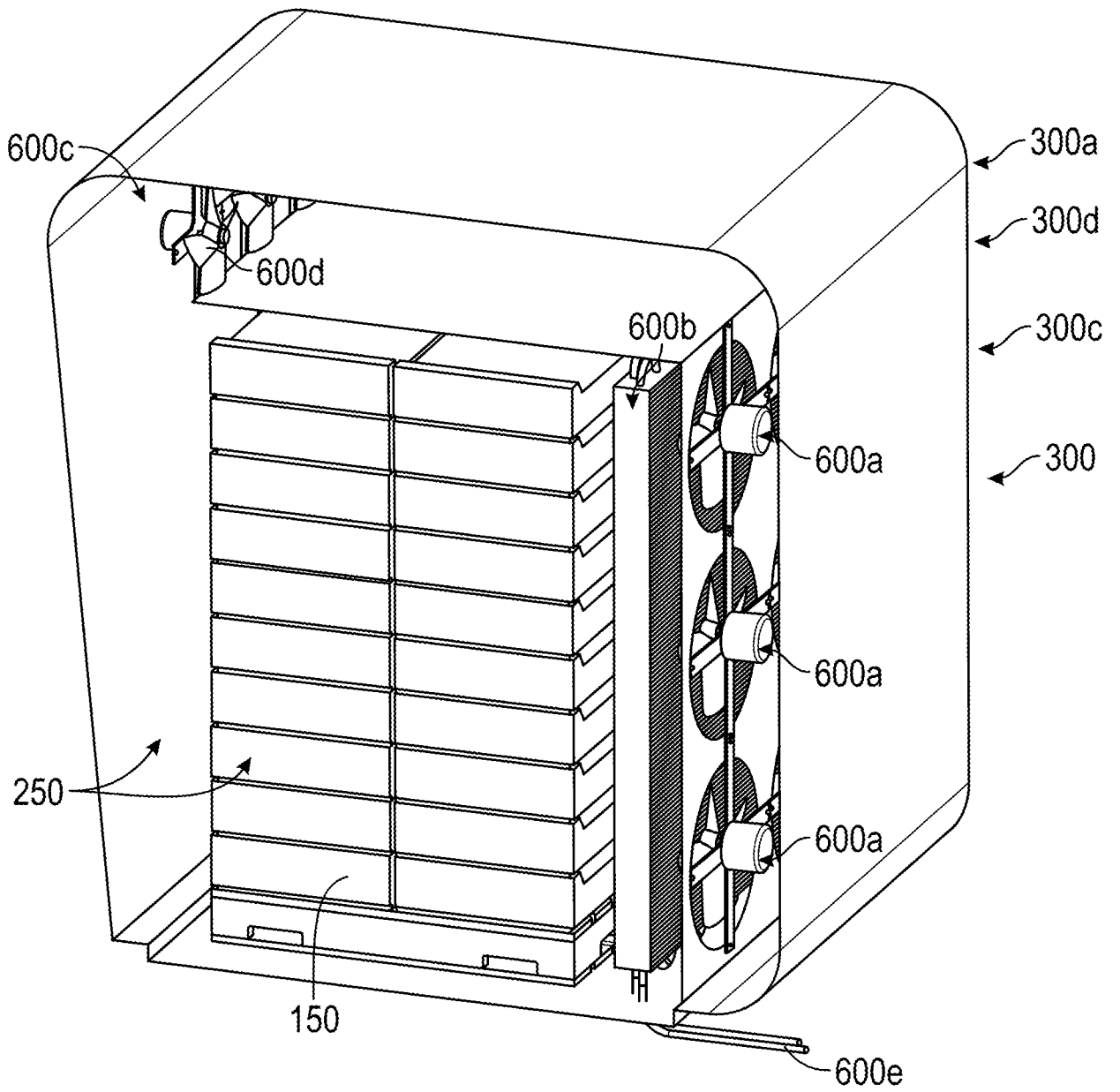

FIG. 11

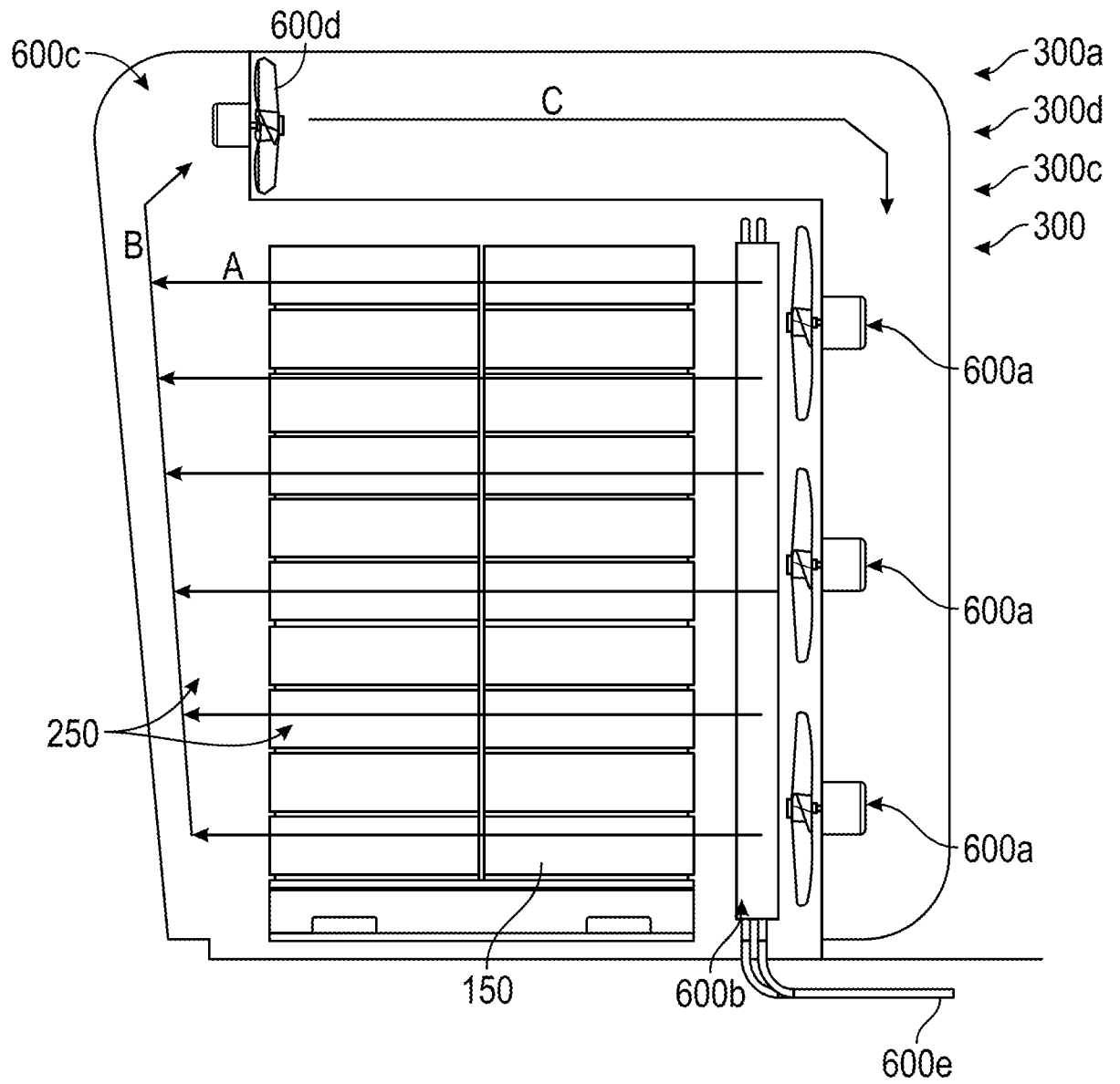

FIG. 12



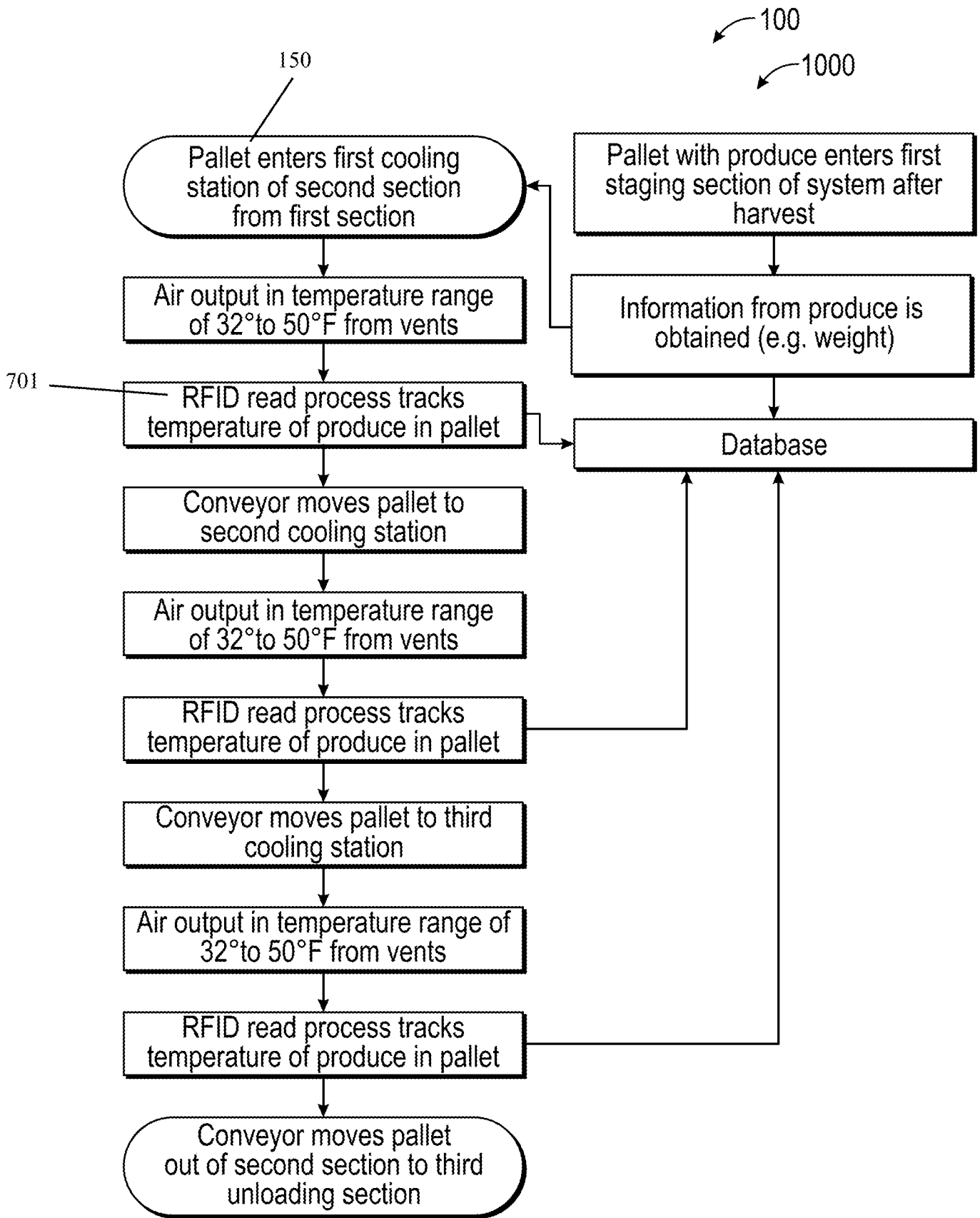

FIG. 13

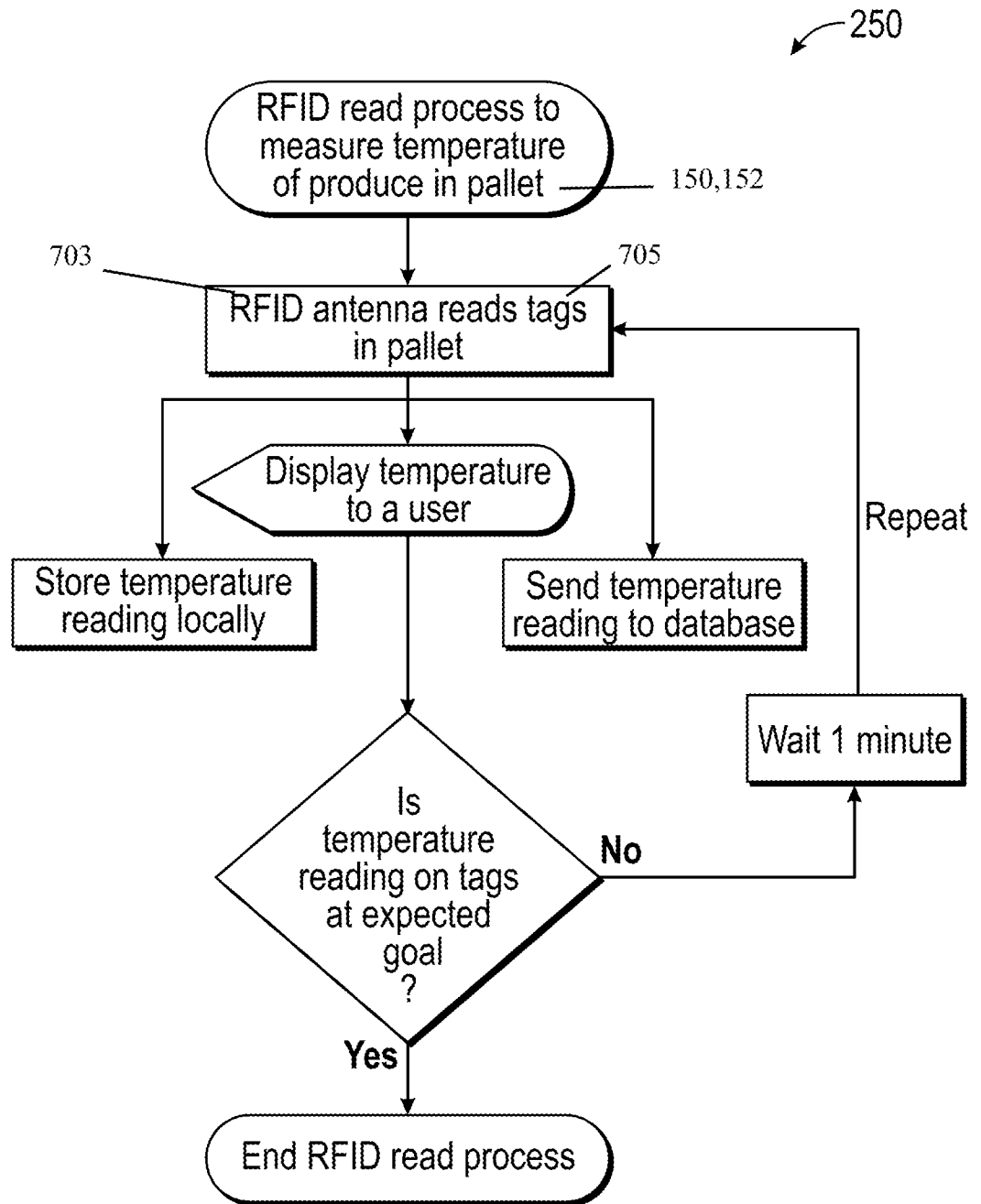

FIG. 13A

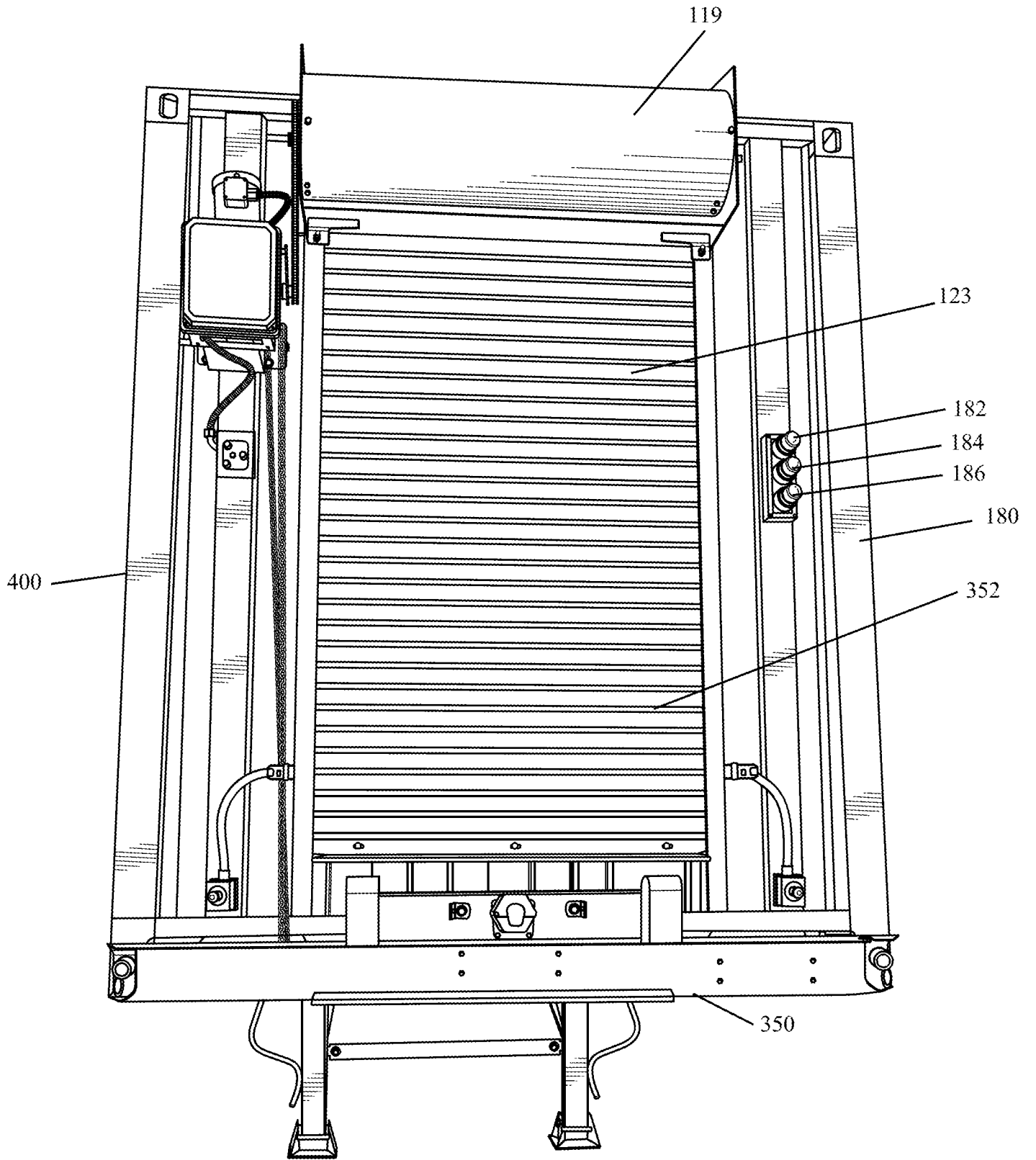

FIG. 14

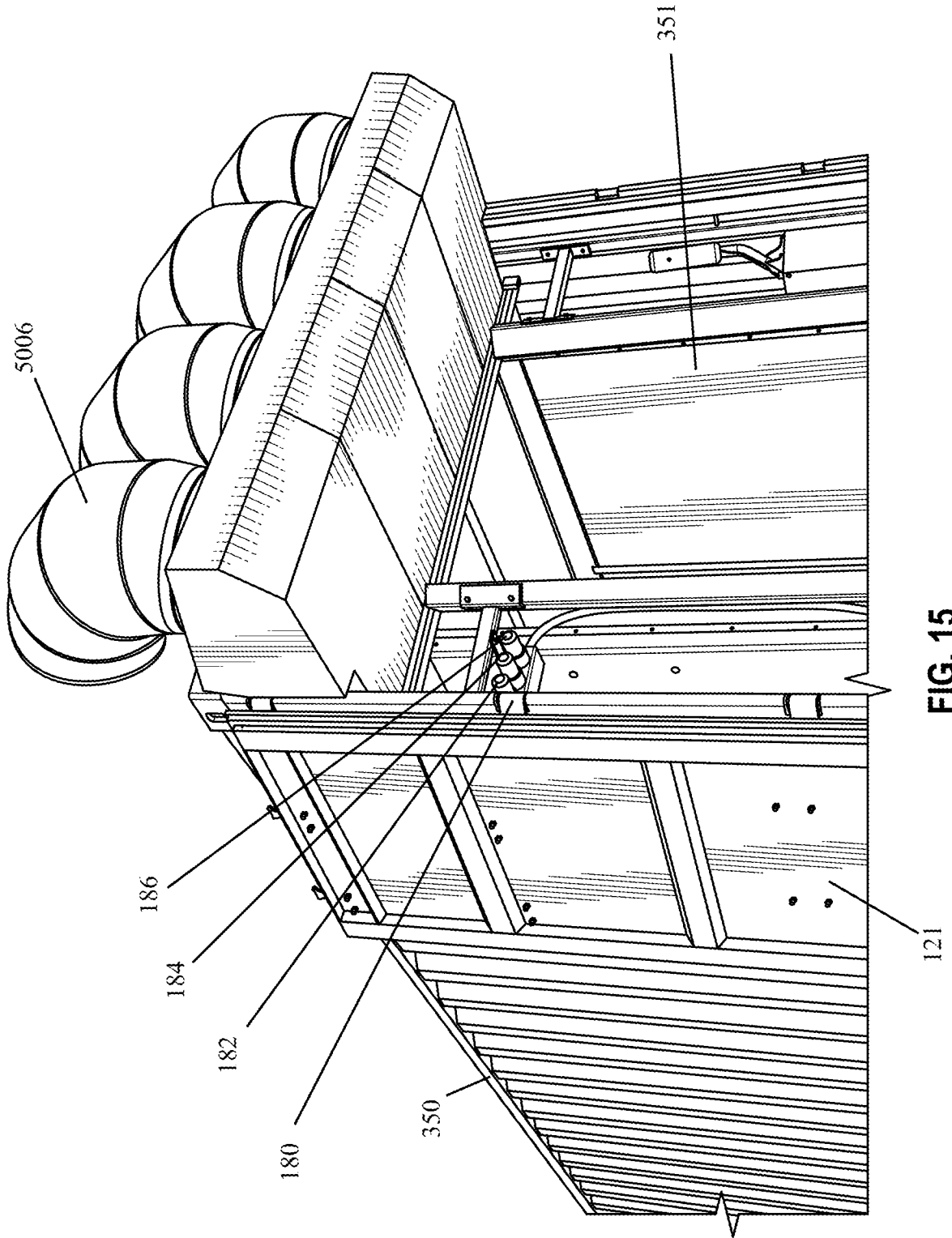

FIG. 15

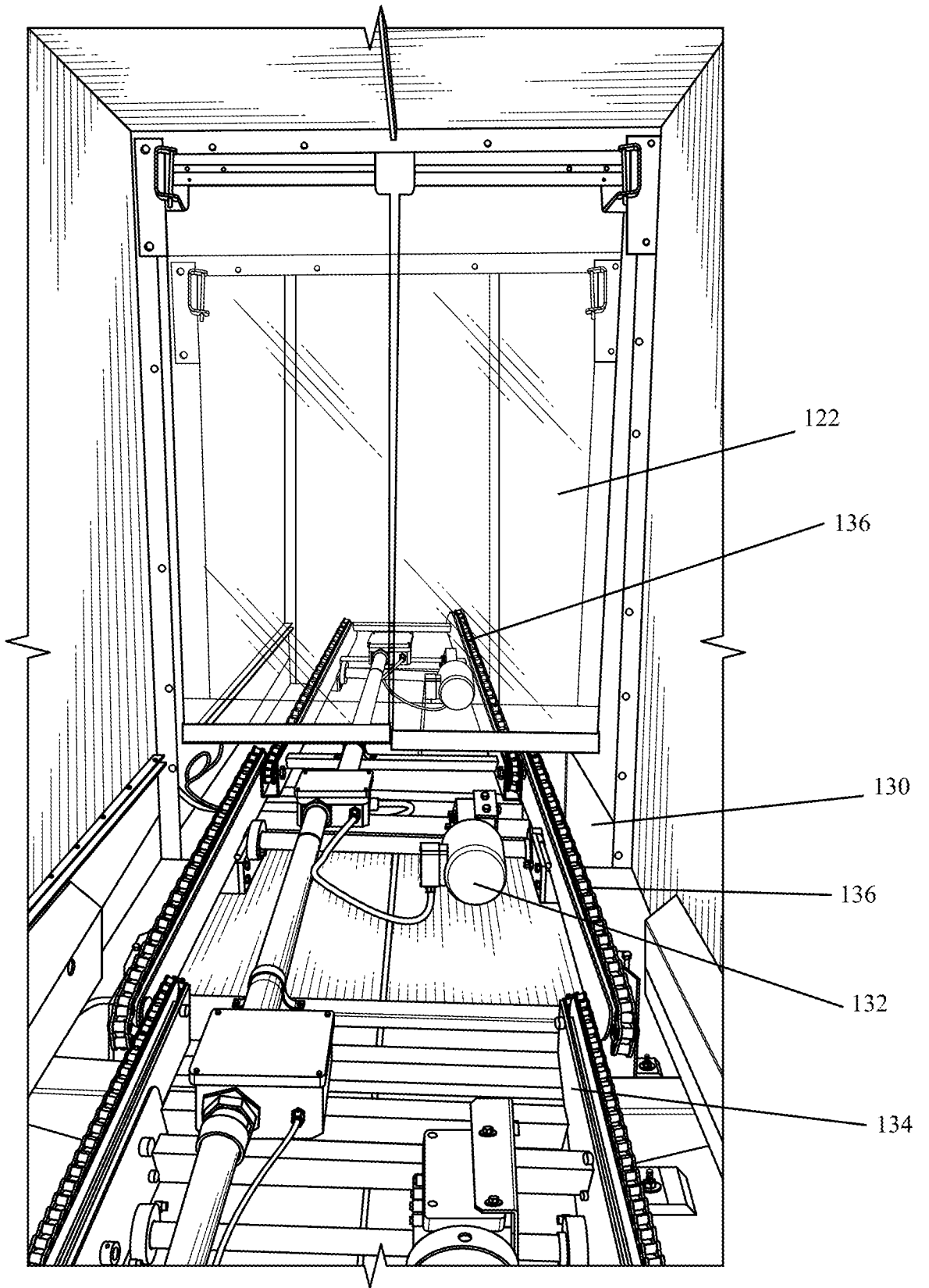
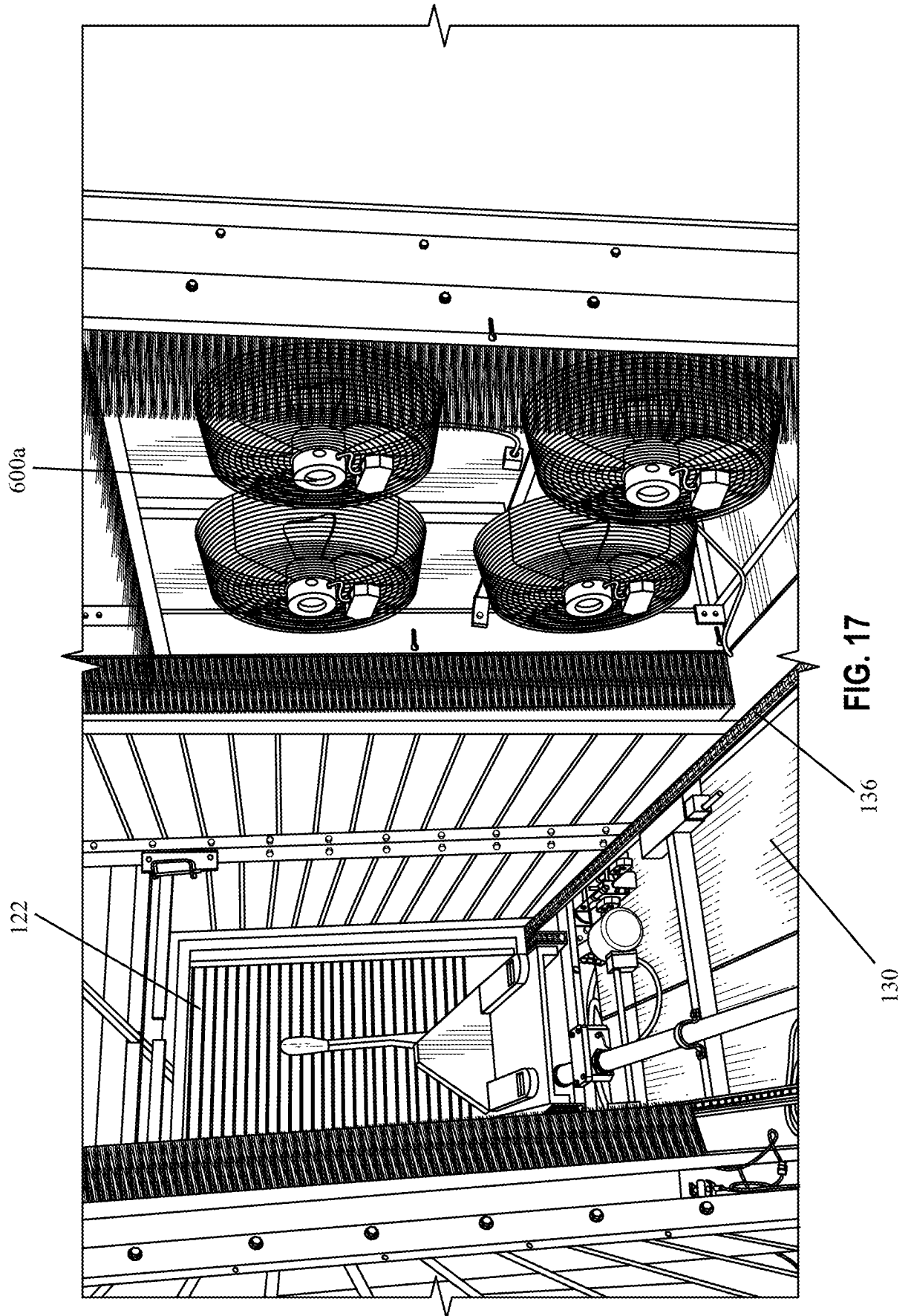

FIG. 16



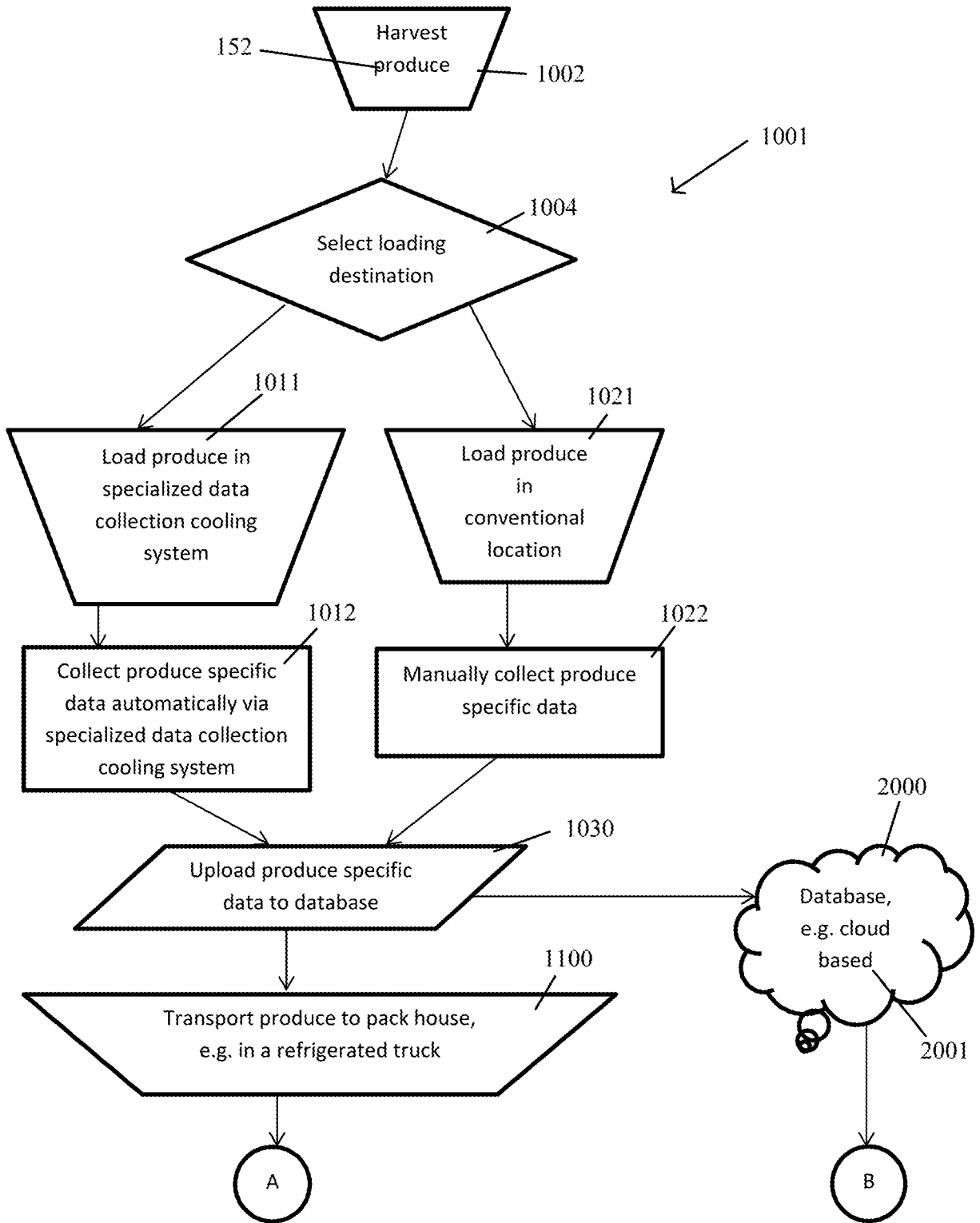

FIG. 18A

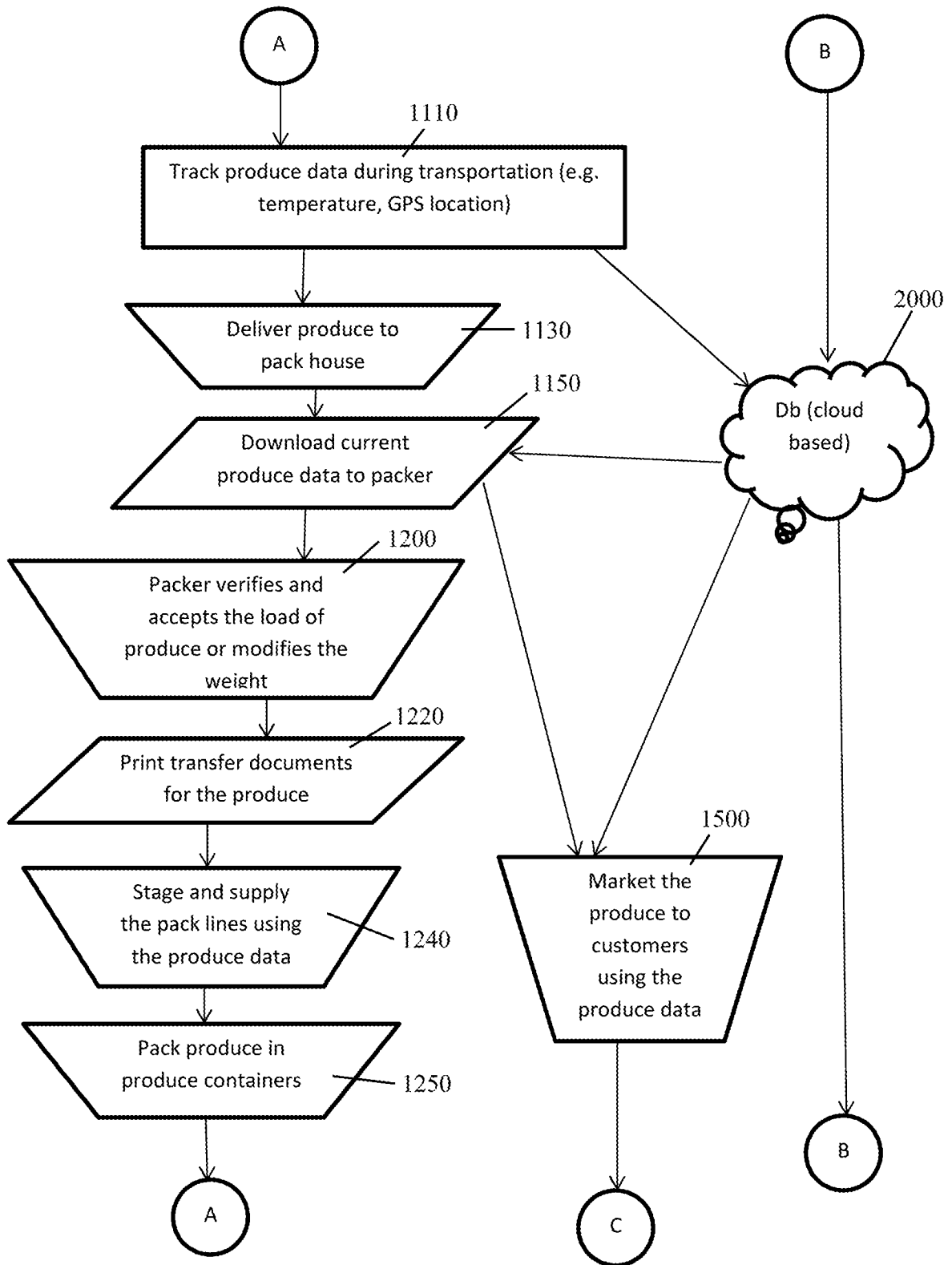

FIG. 18B



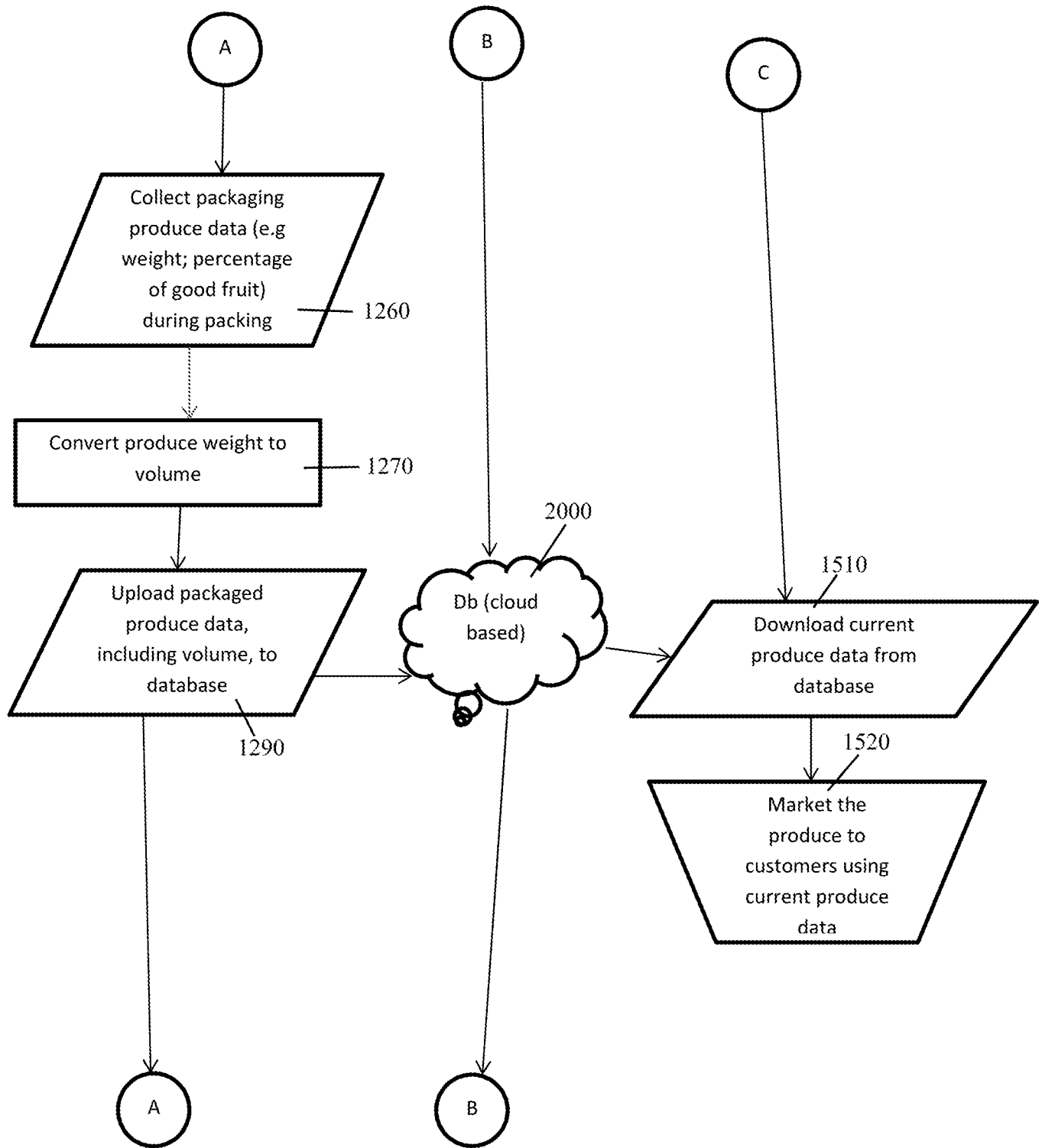

FIG. 18C

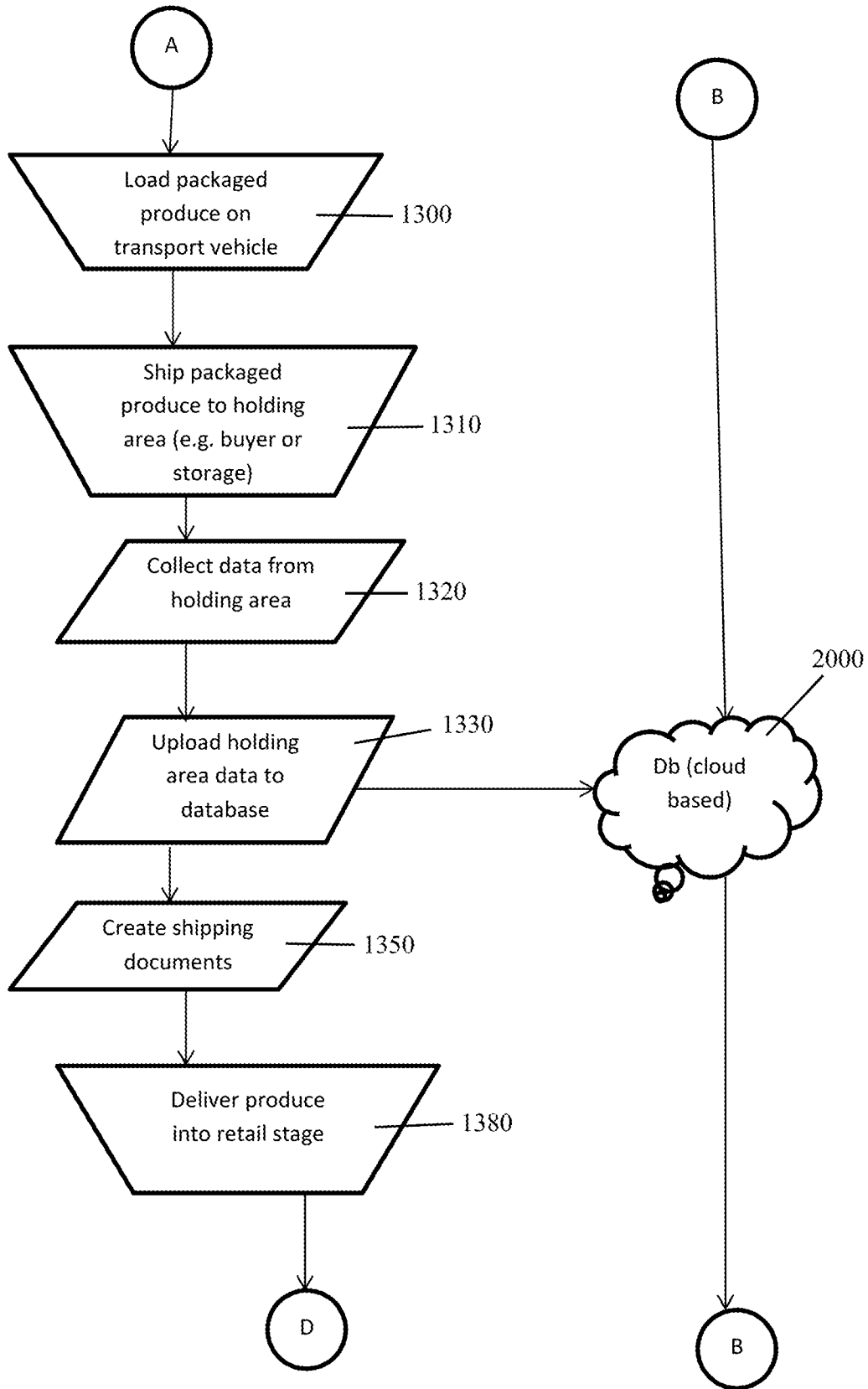

FIG. 18D

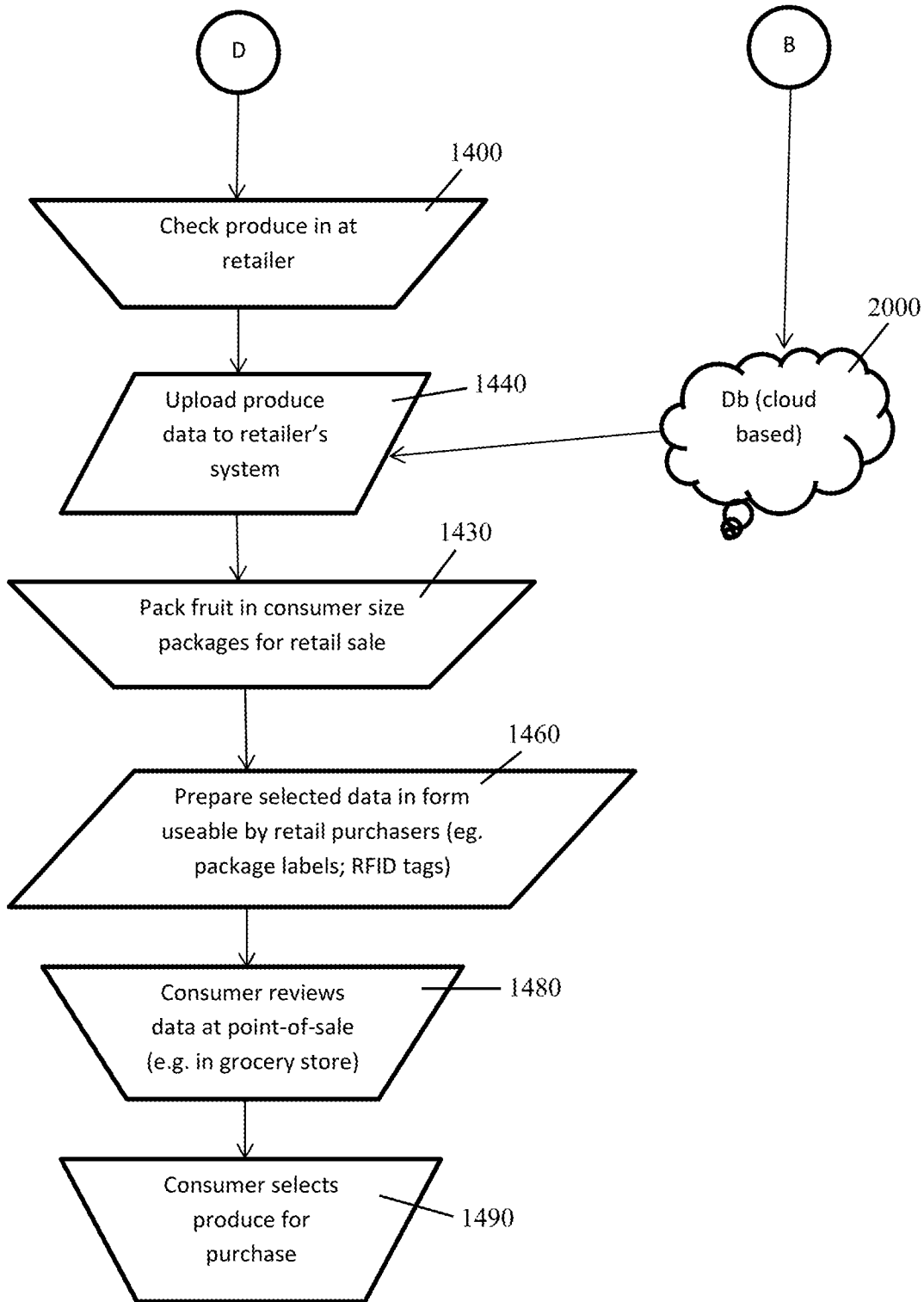

FIG. 18E

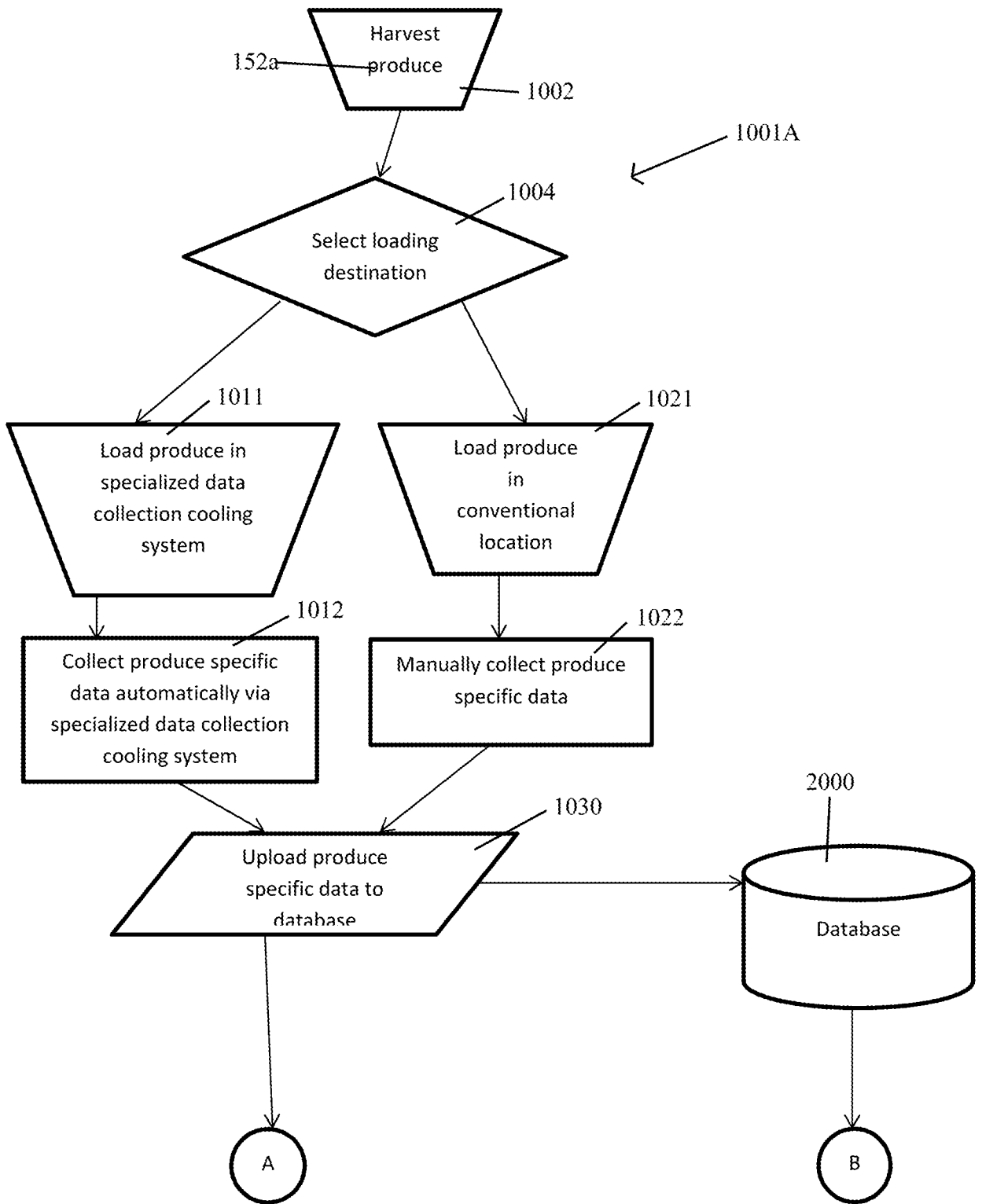

FIG. 19A

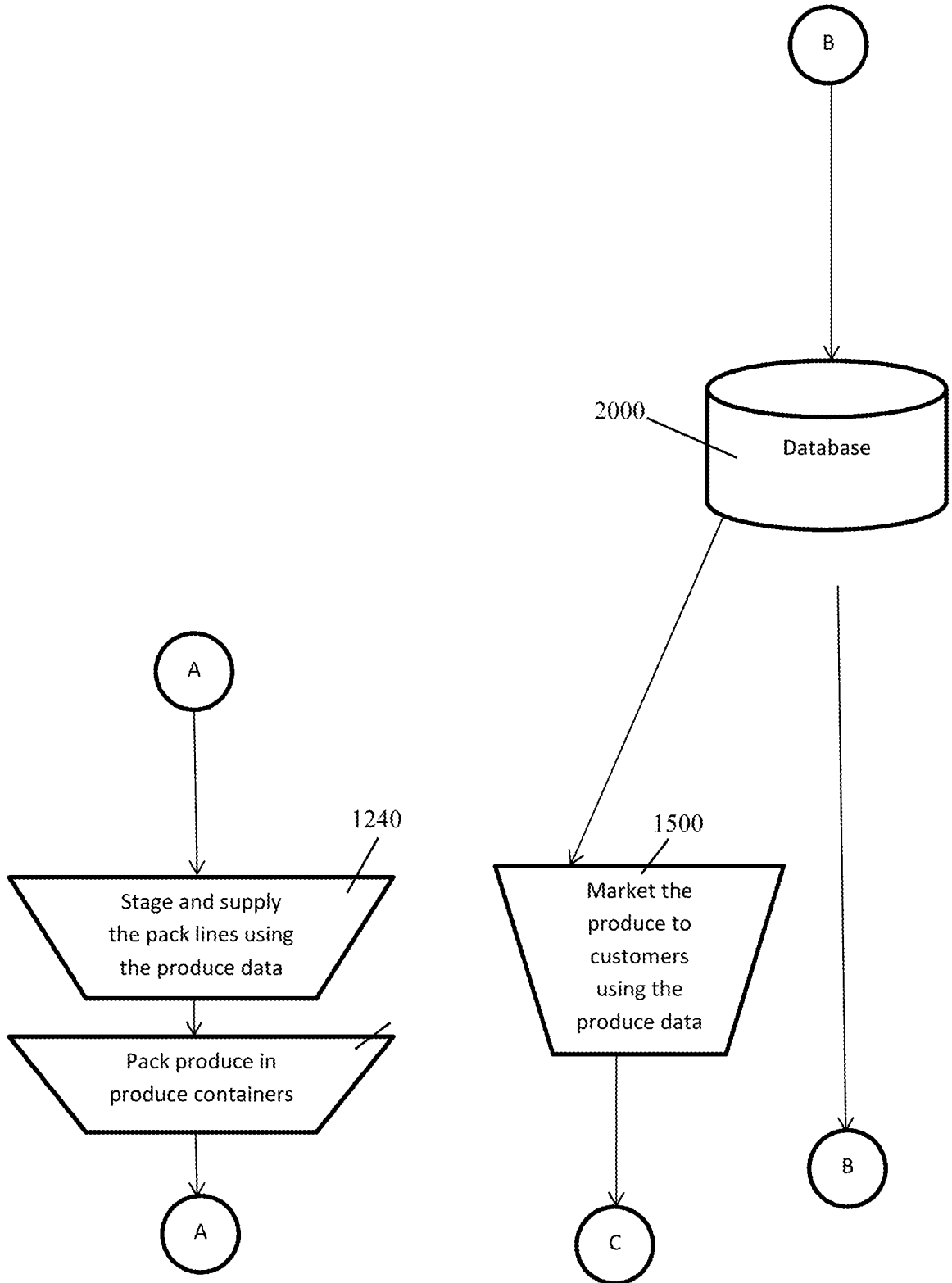

FIG. 19B

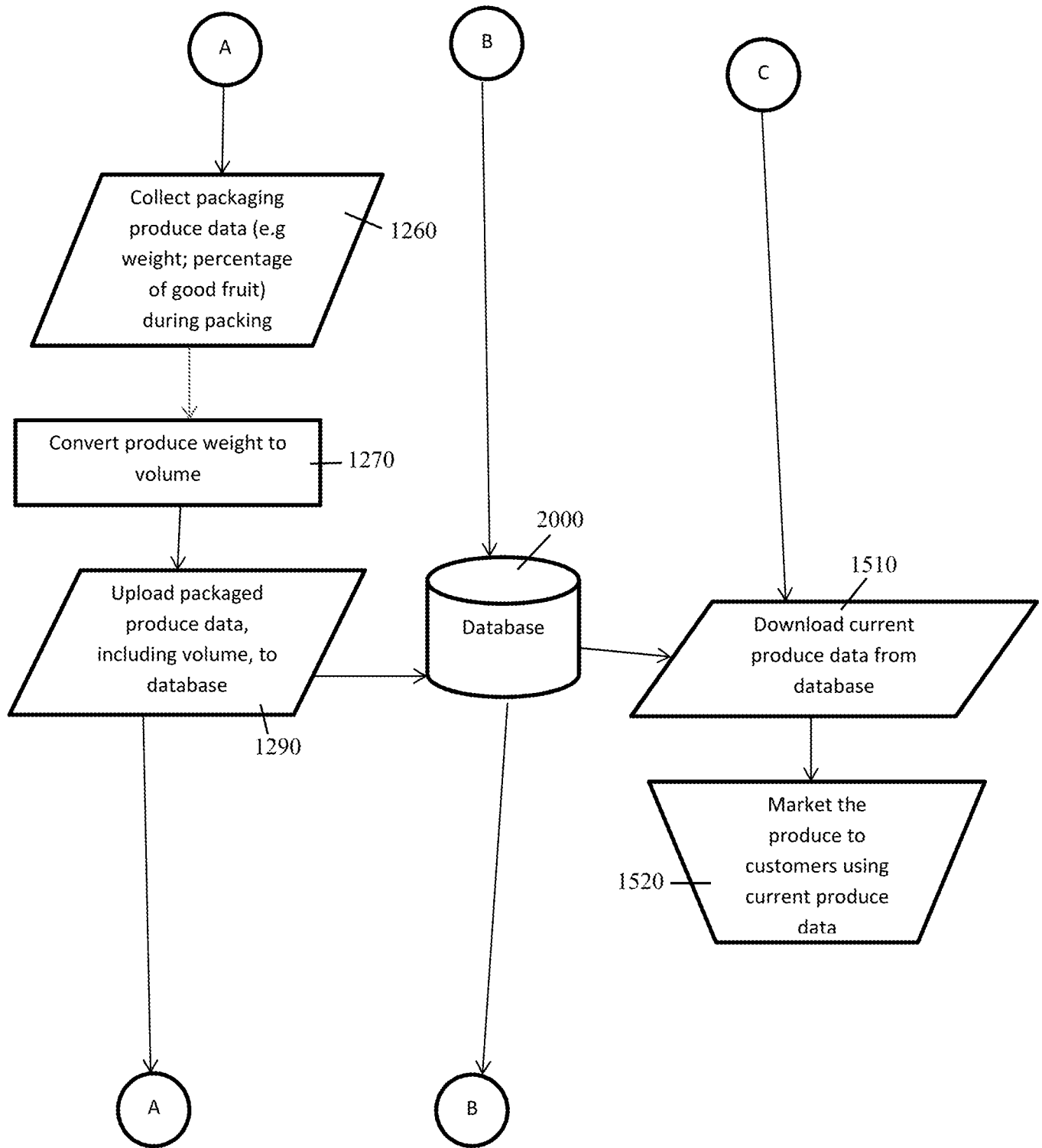

FIG. 19C

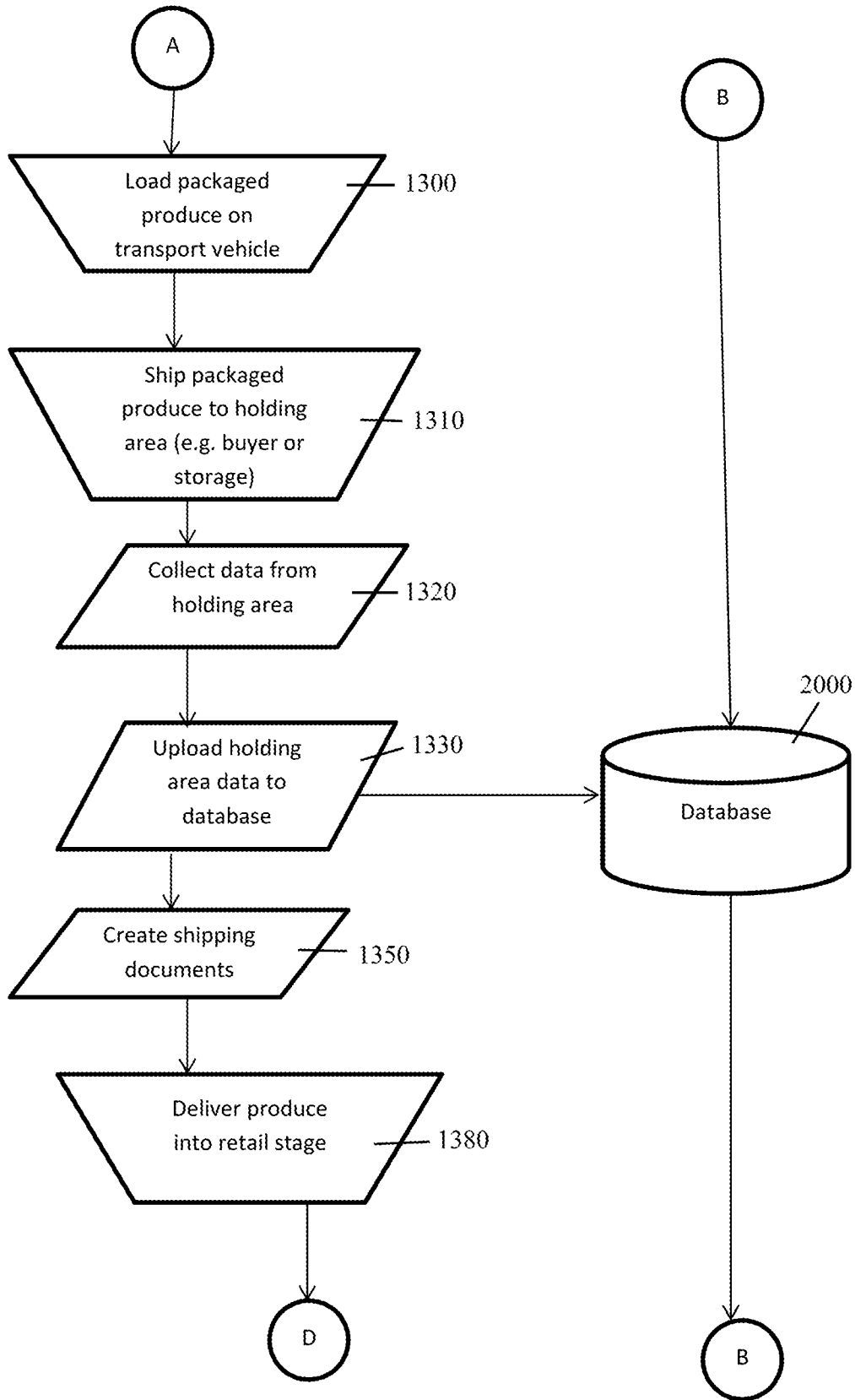

FIG. 19D

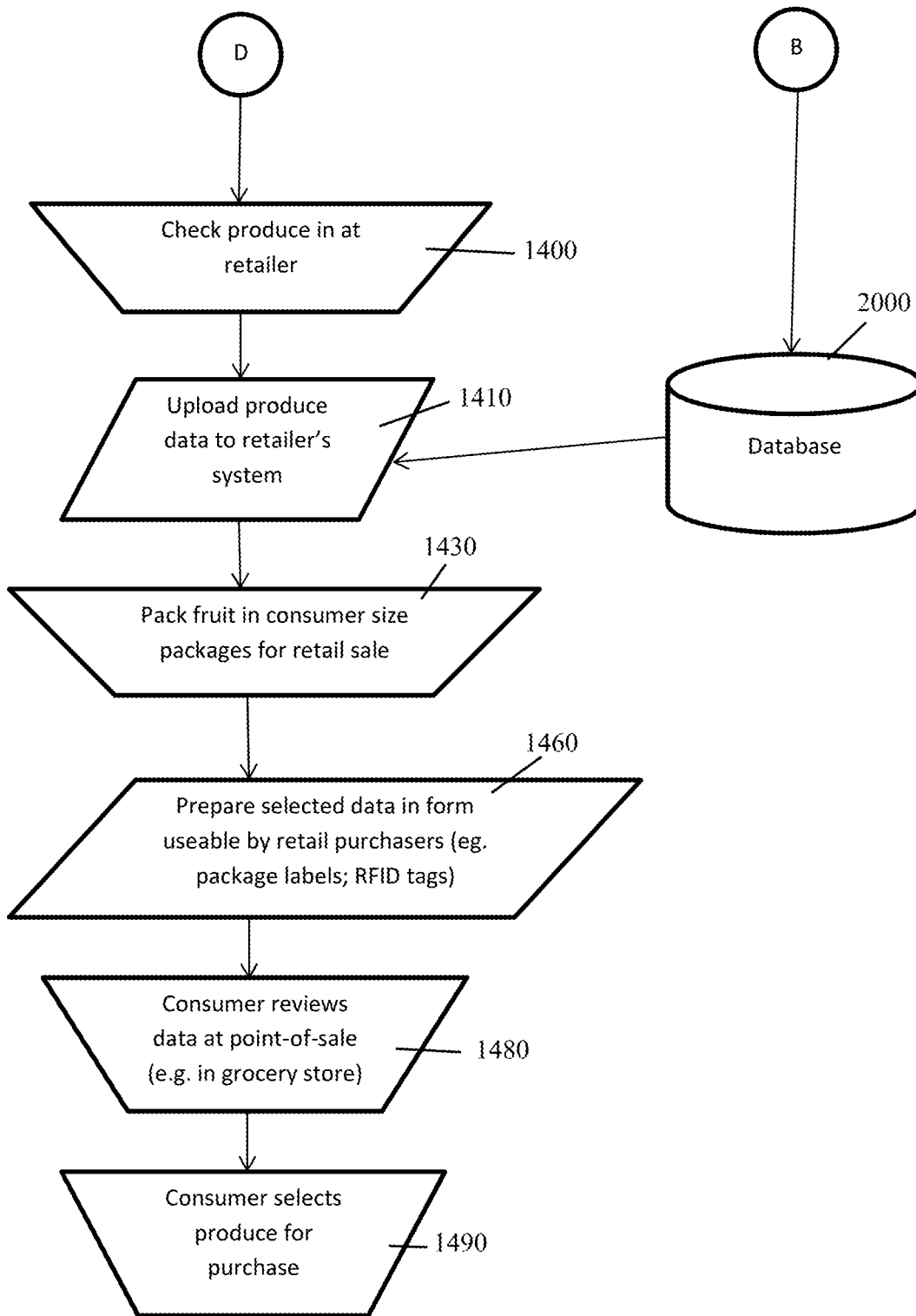

FIG. 19E



INTERNATIONAL SEARCH REPORT

International application No  
PCT/US2017/023052

A. CLASSIFICATION OF SUBJECT MATTER  
INV. F25D11/00 F25D13/06 F25D17/06  
ADD.  
According to International Patent Classification (IPC) or to both national classification and IPC

B. FIELDS SEARCHED  
Minimum documentation searched (classification system followed by classification symbols)  
F25D B60P

Documentation searched other than minimum documentation to the extent that such documents are included in the fields searched

Electronic data base consulted during the international search (name of data base and, where practicable, search terms used)  
EPO-Internal, WPI Data

C. DOCUMENTS CONSIDERED TO BE RELEVANT

Category*	Citation of document, with indication, where appropriate, of the relevant passages	Relevant to claim No.
X	US 2011/138820 A1 (WEETH FREDERIC R [US] ET AL) 16 June 2011 (2011-06-16)	21-30
Y	figures 3-11 paragraph [0042] - paragraph [0045] paragraph [0050] - paragraph [0052] paragraph [0055] - paragraph [0056]	1-20
Y	US 2014/345304 A1 (LEUNG DAVID JOE YEE [CA] ET AL) 27 November 2014 (2014-11-27) paragraph [0074] paragraph [0086]	1-20
Y	US 2007/017233 A1 (HAWKINS SCOTT A [US]) 25 January 2007 (2007-01-25) paragraph [0057]	10,17
	----- -/--	

Further documents are listed in the continuation of Box C.

See patent family annex.

\* Special categories of cited documents :

"A" document defining the general state of the art which is not considered to be of particular relevance

"E" earlier application or patent but published on or after the international filing date

"L" document which may throw doubts on priority claim(s) or which is cited to establish the publication date of another citation or other special reason (as specified)

"O" document referring to an oral disclosure, use, exhibition or other means

"P" document published prior to the international filing date but later than the priority date claimed

"T" later document published after the international filing date or priority date and not in conflict with the application but cited to understand the principle or theory underlying the invention

"X" document of particular relevance; the claimed invention cannot be considered novel or cannot be considered to involve an inventive step when the document is taken alone

"Y" document of particular relevance; the claimed invention cannot be considered to involve an inventive step when the document is combined with one or more other such documents, such combination being obvious to a person skilled in the art

"&" document member of the same patent family

Date of the actual completion of the international search  19 June 2017	Date of mailing of the international search report  27/06/2017
---	--

Name and mailing address of the ISA/ European Patent Office, P.B. 5818 Patentlaan 2 NL - 2280 HV Rijswijk Tel. (+31-70) 340-2040, Fax: (+31-70) 340-3016	Authorized officer  Fernandez Ambres, A
--	---

## INTERNATIONAL SEARCH REPORT

International application No  
PCT/US2017/023052

C(Continuation). DOCUMENTS CONSIDERED TO BE RELEVANT		
Category*	Citation of document, with indication, where appropriate, of the relevant passages	Relevant to claim No.
A	WO 2011/050157 A2 (CARRIER CORP [US]; ZEIDNER LAWRENCE E [US]) 28 April 2011 (2011-04-28) abstract; figures -----	1-30

# INTERNATIONAL SEARCH REPORT

Information on patent family members

International application No

PCT/US2017/023052

Patent document cited in search report	Publication date	Publication date	Patent family member(s)	Publication date
US 2011138820	A1	16-06-2011	NONE	
-----				
US 2014345304	A1	27-11-2014	CA 2852476 A1	24-11-2014
			US 2014345304 A1	27-11-2014
-----				
US 2007017233	A1	25-01-2007	NONE	
-----				
WO 2011050157	A2	28-04-2011	CN 102548627 A	04-07-2012
			EP 2491325 A2	29-08-2012
			US 2012198866 A1	09-08-2012
			WO 2011050157 A2	28-04-2011
-----				