

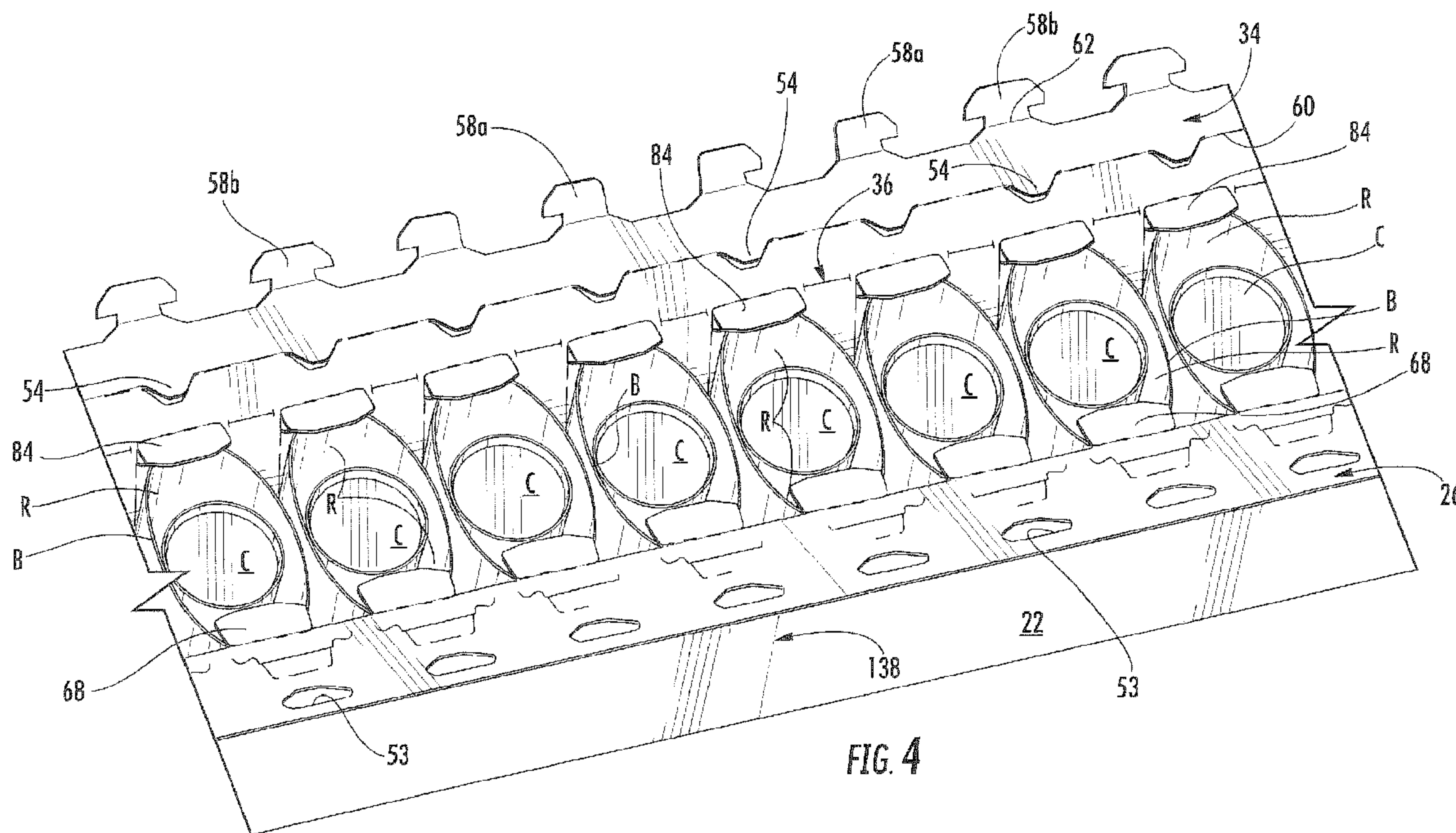

(86) **Date de dépôt PCT/PCT Filing Date:** 2014/10/24  
 (87) **Date publication PCT/PCT Publication Date:** 2015/04/30  
 (85) **Entrée phase nationale/National Entry:** 2016/03/15  
 (86) **N° demande PCT/PCT Application No.:** US 2014/062133  
 (87) **N° publication PCT/PCT Publication No.:** 2015/061659  
 (30) **Priorité/Priority:** 2013/10/25 (US61/961,882)

(51) **Cl.Int./Int.Cl. B65D 71/12** (2006.01)  
 (71) **Demandeur/Applicant:**  
 GRAPHIC PACKAGING INTERNATIONAL, INC., US  
 (72) **Inventeur/Inventor:**  
 SPIVEY, RAYMOND R., SR., US  
 (74) **Agent:** MACRAE & CO.

(54) **Titre : CARTON PORTE-BOUEILLES A CARACTERISTIQUES DE RETENUE**  
 (54) **Title: CARTON WITH RETENTION FEATURES**



(57) **Abrégé/Abstract:**

A carton for carrying a plurality of articles. The carton can comprise a plurality of panels at least partially extending around an interior of the carton. The plurality of panels can comprise a top panel, at least one side panel, and at least one bottom panel. At least one retention tab can be foldably connected to the at least one bottom panel. The at least one retention tab can be for engaging at least a portion of an article of the plurality of articles. At least one corner flap can be foldably connected to the at least one side panel. Each of the at least one retention tab and the at least one corner flap can be disposed adjacent to at least one corner opening in the carton.

(12) INTERNATIONAL APPLICATION PUBLISHED UNDER THE PATENT COOPERATION TREATY (PCT)

(19) World Intellectual Property  
Organization  
International Bureau(43) International Publication Date  
30 April 2015 (30.04.2015)(10) International Publication Number  
WO 2015/061659 A1(51) International Patent Classification:  
B65D 71/12 (2006.01)(21) International Application Number:  
PCT/US2014/062133(22) International Filing Date:  
24 October 2014 (24.10.2014)

(25) Filing Language: English

(26) Publication Language: English

(30) Priority Data:  
61/961,882 25 October 2013 (25.10.2013) US

(71) Applicant: GRAPHIC PACKAGING INTERNATIONAL, INC. [US/US]; Law Department - 9th Floor, 1500 Riveredge Parkway, Suite 100, Atlanta, GA 30328 (US).

(72) Inventor: SPIVEY, Raymond, R.; 475 Ivey Court, Mableton, GA 30126 (US).

(74) Agent: CLAERBOUT, Andrew, N.; Womble Carlyle Sandridge &amp; Rice LLP, P.O. Box 7037, Atlanta, GA 30357-0037 (US).

(81) Designated States (unless otherwise indicated, for every kind of national protection available): AE, AG, AL, AM, AO, AT, AU, AZ, BA, BB, BG, BH, BN, BR, BW, BY, BZ, CA, CH, CL, CN, CO, CR, CU, CZ, DE, DK, DM,

DO, DZ, EC, EE, EG, ES, FI, GB, GD, GE, GH, GM, GT, HN, HR, HU, ID, IL, IN, IR, IS, JP, KE, KG, KN, KP, KR, KZ, LA, LC, LK, LR, LS, LU, LY, MA, MD, ME, MG, MK, MN, MW, MX, MY, MZ, NA, NG, NI, NO, NZ, OM, PA, PE, PG, PH, PL, PT, QA, RO, RS, RU, RW, SA, SC, SD, SE, SG, SK, SL, SM, ST, SV, SY, TH, TJ, TM, TN, TR, TT, TZ, UA, UG, US, UZ, VC, VN, ZA, ZM, ZW.

(84) Designated States (unless otherwise indicated, for every kind of regional protection available): ARIPO (BW, GH, GM, KE, LR, LS, MW, MZ, NA, RW, SD, SL, ST, SZ, TZ, UG, ZM, ZW), Eurasian (AM, AZ, BY, KG, KZ, RU, TJ, TM), European (AL, AT, BE, BG, CH, CY, CZ, DE, DK, EE, ES, FI, FR, GB, GR, HR, HU, IE, IS, IT, LT, LU, LV, MC, MK, MT, NL, NO, PL, PT, RO, RS, SE, SI, SK, SM, TR), OAPI (BF, BJ, CF, CG, CI, CM, GA, GN, GQ, GW, KM, ML, MR, NE, SN, TD, TG).

## Declarations under Rule 4.17:

- as to applicant's entitlement to apply for and be granted a patent (Rule 4.17(ii))
- as to the applicant's entitlement to claim the priority of the earlier application (Rule 4.17(iii))

## Published:

- with international search report (Art. 21(3))

(54) Title: CARTON WITH RETENTION FEATURES

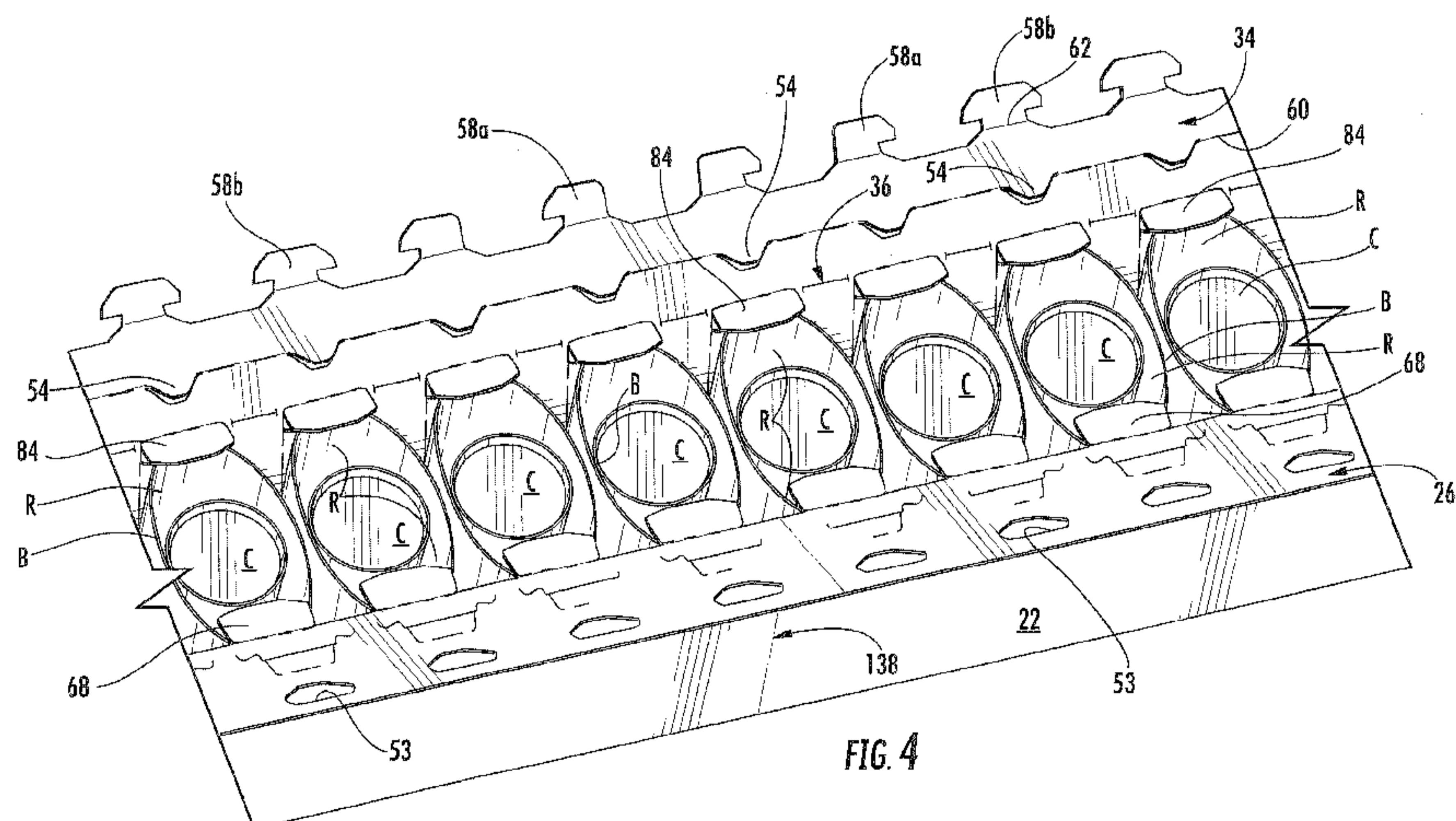

(57) Abstract: A carton for carrying a plurality of articles. The carton can comprise a plurality of panels at least partially extending around an interior of the carton. The plurality of panels can comprise a top panel, at least one side panel, and at least one bottom panel. At least one retention tab can be foldably connected to the at least one bottom panel. The at least one retention tab can be for engaging at least a portion of an article of the plurality of articles. At least one corner flap can be foldably connected to the at least one side panel. Each of the at least one retention tab and the at least one corner flap can be disposed adjacent to at least one corner opening in the carton.

WO 2015/061659 A1

**CARTON WITH RETENTION FEATURES****CROSS-REFERENCE TO RELATED APPLICATIONS**

**[0001]** This application claims the benefit of U.S. Provisional Patent Application No. 61/961,882, filed October 25, 2013.

**INCORPORATION BY REFERENCE**

**[0002]** The disclosure of U.S. Provisional Patent Application No. 61/961,882, which was filed on October 25, 2013, is hereby incorporated by reference for all purposes as if presented herein in its entirety.

**BACKGROUND OF THE DISCLOSURE**

**[0003]** The present disclosure generally relates to carriers and cartons for holding and dispensing product containers or other types of articles.

**SUMMARY OF THE DISCLOSURE**

**[0004]** In general, one aspect of the disclosure is directed to a carton for carrying a plurality of articles. The carton comprises at least one retention tab for engaging at least a portion of an article of the plurality of articles and at least one corner flap. Each of the at least one retention tab and the at least one corner flap is disposed adjacent at least one corner opening in the carton.

**[0005]** In another aspect, the disclosure is generally directed to a carton for carrying a plurality of articles. The carton can comprise a plurality of panels at least partially extending around an interior of the carton. The plurality of panels can comprise a top panel, at least one side panel, and at least one bottom panel. At least one retention tab can be foldably connected to the at least one bottom panel. The at least one retention tab can be for engaging at least a portion of an article of the plurality of articles. At least one corner flap can be foldably connected to the at least one side panel. Each of the at least one retention tab and the at least one corner flap can be disposed adjacent to at least one corner opening in the carton.

**[0006]** In another aspect, the disclosure is generally directed to a blank for forming a carton for holding a plurality of articles. The blank can comprise a plurality of panels comprising a top panel, at least one side panel, and at least one bottom panel. At least one retention tab can be foldably connected to the at least one bottom panel. At least one corner flap can be foldably connected to the at least one side panel. The at least one retention tab can be at least partially separable from the at

least one corner flap along at least one cut line for forming at least one corner opening in the carton formed from the blank.

[0007] In another aspect, the disclosure is directed to a method of forming a carton for holding a plurality of articles. The method can comprise obtaining a blank comprising a plurality of panels comprising a top panel, at least one side panel, and at least one bottom panel, at least one retention tab foldably connected to the at least one bottom panel, and at least one corner flap foldably connected to the at least one side panel. The at least one retention tab can be at least partially separable from the at least one corner flap along at least one cut line. The method further can comprise forming an interior of the carton at least partially defined by the plurality of panels. The forming the interior can comprise folding the at least one bottom panel with respect to the at least one side panel. The method also can comprise at least partially engaging the at least one retention tab with a bottom portion of an article of the plurality of articles. The engaging the at least one retention tab can at least partially form a corner opening in the carton.

[0008] Other aspects, features, and details of the present disclosure can be more completely understood by reference to the following detailed description of exemplary embodiments taken in conjunction with the drawings and from the appended claims.

[0009] Those skilled in the art will appreciate the above stated advantages and other advantages and benefits of various additional embodiments reading the following detailed description of the embodiments with reference to the below-listed drawing figures. Further, the various features of the drawings discussed below are not necessarily drawn to scale. Dimensions of various features and elements in the drawings may be expanded or reduced to more clearly illustrate the embodiments of the disclosure.

#### **BRIEF DESCRIPTION OF THE DRAWINGS**

[0010] Fig. 1 is a plan view of an exterior surface of a blank used to form a carton according to an exemplary embodiment of the disclosure.

[0011] Figs. 2A, 2B, and 3 are plan views of respective portions of the blank of Fig. 1.

[0012] Figs. 4-6 are perspective bottom views of a partially-assembled carton according to the exemplary embodiment showing the engagement of a plurality of retention tabs with a plurality of articles in the carton.

[0013] Fig. 7 is a perspective bottom view of the carton showing the bottom panels folded over the bottom of the carton according to the exemplary embodiment.

[0014] Corresponding parts are designated by corresponding reference numbers throughout the drawings.

#### DETAILED DESCRIPTION OF THE EXEMPLARY EMBODIMENTS

[0015] The present disclosure generally relates to various features for cartons or carriers that contain articles such as containers, bottles, cans, etc. The articles can be used for personal care or food products, for example. The articles can be made from materials suitable in composition for packaging the product, and the materials include, but are not limited to, aluminum and/or other metals; glass; plastics such as PET, LDPE, LLDPE, HDPE, PP, PS, PVC, EVOH, and Nylon; and the like, or any combination thereof.

[0016] Cartons or carriers according to the present disclosure can accommodate articles of any shape. For the purpose of illustration and not for the purpose of limiting the scope of the disclosure, the following detailed description describes product containers (e.g., plastic personal care containers) as disposed within the carrier embodiments. In this specification, the terms “inner,” “interior,” “outer,” “exterior,” “lower,” “bottom,” “upper,” and “top” indicate orientations determined in relation to fully erected and upright cartons.

[0017] Fig. 1 is a plan view of an exterior surface 2 of a blank 3, used to form a carton 5 (Fig. 7) according to an exemplary embodiment of the disclosure. The carton 5 can be used to house a plurality of articles such as containers C (Fig. 4-7). In the illustrated embodiment, the containers C are product containers (e.g., deodorant containers, and/or other suitable articles) and the carton 5 is sized to house 12 containers C in a single layer in a 1x12 arrangement, but it is understood that the carton 5 may be sized and shaped to hold containers C of a different or same quantity in more than one layer and/or in different row/column arrangements (e.g., 1x6, 2x3, 2x6, 2x4, 2x2, 2x6x2, 2x4x2, 2x9, etc.). In the illustrated embodiment, the carton 5 can include bottom retention features 9 for engaging the bottom portions B of the containers C and top retention features 11 for engaging the top portions (not shown) of the containers C.

[0018] In the illustrated embodiment, the blank 3 has ends 6, 8 that can form at least partially closed ends (not shown) in the carton 5, and the carton can wrap around the containers C (e.g., the carton 5 may be referred to as a wrap-around carton). The carton 5 could be otherwise shaped and arranged such the ends 6, 8 are generally open or fully closed such as by end flaps or other closing mechanisms.

**[0019]** The blank 3 has a longitudinal axis L1 and a lateral axis L2. In the illustrated embodiment, the blank 3 comprises a top panel 20 foldably connected to a first side panel 22 at a first longitudinal fold line 24, a first bottom panel 26 foldably connected to the first side panel 22 at a second longitudinal fold line 28, a second side panel 30 foldably connected to the top panel 20 at a third longitudinal fold line 32, and a second bottom panel 34 foldably connected to the second side panel 30 at a fourth longitudinal fold line 36. In the illustrated embodiment, the first side panel 22 includes a first bottom corner panel 38 defined by longitudinal fold lines 28 and 40. The second side panel 30 includes a second bottom corner panel 42 defined by longitudinal fold lines 36 and 44. Additionally, the first side panel 22 can include a first top corner panel 46 defined by longitudinal fold lines 24 and 48, and the second side panel 30 can include a second top corner panel 50 defined by longitudinal fold lines 32 and 52.

**[0020]** The first bottom panel 26, which is the inner bottom panel flap in the assembled carton 5, includes cutouts forming primary female locking edges 53 that are shaped and positioned to engage primary male locking tab projections 54 on the second bottom panel 34. The first bottom panel 26 also includes asymmetric slits 56a and generally symmetric slits 56b shaped and positioned to receive respective outer secondary locking tab projections 58a, 58b of the second bottom panel 34. The secondary locking tab projections 58a can be asymmetric to correspond with the asymmetric slits 56a, and the secondary locking tab projections 58b can be generally symmetric to correspond with the symmetric slits 56b. Accordingly, the asymmetric secondary locking tabs 58a can have a single prong 59a (Fig. 2B), and the asymmetric slits 56a can have a single side cut 57a (Fig. 2A) for receiving the single prong 59a of a respective asymmetric secondary locking tab 58a. The symmetric secondary locking tabs 58b can have two prongs 59b (Fig. 2B), and the symmetric slits 56b can have two side cuts 57b (Fig. 2A) for receiving the respective prongs 59b of a respective symmetric secondary locking tab 58b.

**[0021]** In the illustrated embodiment, the side cuts 57a, 57b of the respective asymmetric slits 56a and symmetric slits 56b can be curved and can at least partially define a respective locking flap 61 (Fig. 2A). As shown in Figs. 1 and 2A, each of the locking flaps 61 can be foldably connected to the first bottom panel 26 along a respective longitudinal fold line 63 and can be at least partially separable from the first bottom panel 26 along a respective longitudinal cut 65. Accordingly, the locking flaps 61 can be folded inwardly with respect to the first bottom panel 26 and engage the respective secondary locking tabs 58a, 58b when the secondary locking tabs are received in the respective slits 56a, 56b.

[0022] In one embodiment, the second bottom panel 34, which is the outer bottom panel in the completed carton 5, includes a longitudinal fold line 60, which is interrupted by slits 55 that at least partially define the primary male locking tab projections 54 (Fig. 2B). In addition, each of the secondary locking tab projections 58a, 58b can include a longitudinal fold line 62. Although the locking elements of the blank 3 are illustrated to demonstrate a particular bottom panel locking arrangement suitable for use with the carton 5, it is understood that any alternative form of bottom panel locking structure may be employed without departing from the disclosure. For example, all of the slits 56a, 56b and/or all of the secondary locking projections 58a, 58b can be symmetric or asymmetric.

[0023] As shown in Figs. 1-2B, the bottom retention features 9 can include a row of first retention features 64 extending in the first bottom corner panel 38 and a row of second retention features 66 extending in the second bottom corner panel 42. As shown in Fig. 2A, each of the first retention features 64 includes a retention tab 68 adjacent to two corner flaps 70. In the illustrated embodiment, the retention tab 68 in each of the first retention features 64 can be foldably connected to the first bottom panel 26 along a fold line 72 (e.g., an arcuate fold line) and the corner flaps 70 in each of the first retention features 64 can be foldably connected to the first side panel 22 along a fold line 74. In one embodiment, the fold lines 72, 74 can be offset from the respective fold lines 28, 40 so that the retention tabs 68 interrupt the fold line 28 and the corner flaps 70 interrupt the fold line 40. Alternatively, the fold lines 72, 74 could be collinear with the respective fold lines 28, 40, or could be otherwise configured. As shown in Figs. 1 and 2A, each of the retention tabs 68 is separable from the first bottom panel 26 and the first bottom corner panel 38 along curved cut lines 75 and is separable from the adjacent corner flaps 70 along a cut line 76. The corner flaps 70 of each of the first retention features 64 are separable from one another along a cut line 78. In an alternative embodiment, the cut lines 76, 78 could be replaced by tear lines, openings, or other suitable features. As shown in Fig. 2A, the corner flaps 70 are separable from the first side panel 22 and the first bottom corner panel 38 along respective cut lines 80 and are connected to the first bottom corner panel 38 at a respective nick 82, which interrupts the respective cut line 80. In an alternative embodiment, the corner flaps 70 could be otherwise foldably connected and/or separable from the first bottom corner panel 38 (e.g., along a fold line, a tear line, or other suitable feature).

[0024] As shown in Fig. 2B, each of the second retention features 66 includes a retention tab 84 adjacent to two corner flaps 86. In the illustrated embodiment, the retention tab 84 in each of the second retention features 66 can be foldably connected to the second bottom panel 34 along a fold line 88 and the corner flaps 86 in each of the second retention features 66 can be foldably connected to the second side panel 30 along a fold line 90. In one embodiment, the fold lines 88, 90 can be

offset from the respective fold lines 36, 44 so that the retention tabs 84 interrupt the fold line 36 and the corner flaps 86 interrupt the fold line 44. Alternatively, the fold lines 88, 90 could be collinear with the respective fold lines 36, 44, or could be otherwise configured. As shown in Figs. 1 and 2B, each of the retention tabs 84 is separable from the second bottom panel 34 and the second bottom corner panel 42 along curved cut lines 91 and is separable from the adjacent corner flaps 86 along a cut line 92. The corner flaps 86 of each of the second retention features 66 are separable from one another along a cut line 94. In an alternative embodiment, the cut lines 92, 94 could be replaced by tear lines, openings, or other suitable features. As shown in Fig. 2B, the corner flaps 86 are separable from the second side panel 30 and the second bottom corner panel 42 along respective cut lines 96 and are connected to the second bottom corner panel 42 at a respective nick 98, which interrupts the respective cut line 96. In an alternative embodiment, the corner flaps 86 could be otherwise foldably connected and/or separable from the second bottom corner panel 42 (e.g., along a fold line, a tear line, or other suitable feature).

**[0025]** In the illustrated embodiment, each of the retention tabs 68, 84 is positioned to engage at least a portion of a recess R at the bottom B of a respective container C (Figs. 4-7). One or more of the first bottom corner features 64 and/or the second bottom corner features 66 could be omitted or could be otherwise shaped, arranged, positioned, and/or configured without departing from the disclosure.

**[0026]** As shown in Figs. 1 and 3, the top retention features 11 include a row of retention features 100 in the first top corner panel 46 and a row of retention features 102 in the second top corner panel 50. Each of the retention features 100 can include two corner flaps 104 adjacent an opening 106, and each of the retention features 102 can include two corner flaps 108 adjacent an opening 110. The corner flaps 104 can be foldably connected to the first top corner panel 46 along respective fold lines 112, and the corner flaps 108 can be foldably connected to the second top corner panel 50 along respective fold lines 114. In the illustrated embodiment, the corner flaps 104 can be separable from the first side panel 22 along a cut line 116 and from one another along a cut line 118, and the corner flaps 108 can be separable from the second side panel 30 along a cut line 120 and from one another along a cut line 122. In one embodiment, projections 124 can extend from the top panel 20 adjacent the openings 106, 110. As shown in Fig. 1 and 3, the projections 124 can interrupt the fold lines 24, 32, the corner flaps 104 can interrupt the fold line 48, and the corner flaps 108 can interrupt the fold line 52. One or more of the retention features 100, 102 could be omitted or could be otherwise shaped, arranged, positioned, and/or configured without departing from the disclosure.



[0027] In one embodiment, the first side panel 22 is foldably connected to a first side end flap 126 and a second side end flap 128, and the second side panel 30 is foldably connected to a first side end flap 130 and a second side end flap 132. When the carton 5 is erected, the side end flaps 126, 130 close the first end 6 of the carton, and the side end flaps 128, 132 close the second end 8 of the carton. In accordance with an alternative embodiment of the present disclosure, different flap arrangements can be used for closing the ends 6, 8 of the carton.

[0028] As shown in Fig. 1, the end flaps 126, 130 extend along a first marginal area of the blank 3, and can be foldably connected at a first lateral fold line 134 that extends along the width of the blank. The end flaps 128, 132 extend along a second marginal area of the blank 3, and can be foldably connected at a second lateral fold line 136 that also extends along the width of the blank. The lateral fold lines 134, 136 may be, for example, substantially straight or offset at one or more locations to account for blank thickness or for other factors. The blank 3 could have other end flap arrangements without departing from the disclosure.

[0029] In the illustrated embodiment, the blank 3 can include a transverse tear line 138 extending along a centerline of the blank. Accordingly, the lateral tear line 138 can be actuated to separate the erected carton 5 into two portions. The tear line 138 could be omitted or could be otherwise positioned, shaped, and/or arranged without departing from the disclosure. For example, the tear line 138 could be offset from the centerline of the blank 3. In one alternative embodiment, the blank 3 could include dispenser features for accessing the containers C in the carton 5.

[0030] As shown in Figs. 4-7, the carton 5 can be erected by wrapping the blank 3 around the containers C and interlocking the first and second bottom panels 26, 34 with the bottom retention features 9 actuated to engage the recess features R of the containers C. As shown in Fig. 4, the containers C are arranged in a row on the top panel 20 so that the tops (not shown) of the containers C are aligned with the top retention features 11. The side panels 22, 30 can be folded upwardly along respective fold lines 24, 32 so that the tops of the containers C contact the corner flaps 104, 108 and are received in the openings 106, 110 (not shown). As the side panels 22, 30 are folded, the bottom panels 26, 34 can be folded outwardly along the respective fold lines 28, 36. As shown in Fig. 4, the outwardly folding of the bottom panels can cause the retention tabs 68, 84 to separate from the respective bottom corner panels 38, 42, folding along respective fold lines 72, 88. Accordingly, the retention tabs 68, 84 can be aligned with the recesses R of the containers C when the side panels 22, 30 are brought into contact with the sides of the containers. In one embodiment, the retention tabs 68, 84 can separate from the respective corner panels 38, 42 during folding without being pushed by a tool, for example. Alternatively, the retention tabs could be forced to separate from the respective corner panels with a suitable tool, for example.

**[0031]** As shown in Figs. 5 and 6, the first bottom panel 26 can be folded over the bottoms B of the containers C, and the retention tabs 68 can be pushed down into the respective recesses R of the respective containers. In one embodiment, the retention tabs 68 can rotate into the recesses R of the containers when the bottom panel 26 is folded over the bottom of the carton 5 along fold line 28. Alternatively, the retention tabs 68 can be forced into the recesses R by a suitable tool, for example. In the illustrated embodiment, the corner flaps 70 can be folded outwardly about fold lines 74 and at nicks 82 by contact with the bottoms B of the respective containers C. Accordingly, the bottoms B of the containers C can extend into respective openings 142 formed in the respective first retention features 64.

**[0032]** Similarly, as shown in Fig. 7, the second bottom panel 34 can be folded over the bottoms B of the containers C and the first bottom panel 26, and the retention tabs 84 can be pushed down into the respective recesses R of the respective containers. In one embodiment, the retention tabs 84 can rotate into the recesses R of the containers when the bottom panel 34 is folded over the bottom of the carton 5 along fold line 36. Alternatively, the retention tabs 84 can be forced into the recesses R by a suitable tool, for example. In the illustrated embodiment, the corner flaps 86 can be folded outwardly about fold lines 90 and at nicks 98 by contact with the bottoms B of the respective containers C. Accordingly, the bottoms B of the containers C can extend into respective openings 144 formed in the respective second retention features 66.

**[0033]** In one embodiment, the second bottom panel 34 is secured to the first bottom panel 26 by first respectively engaging primary male locking tabs 54 with the primary female locking edges 53. The primary male locking tabs 54 can be separated from the second bottom panel 34 by folding the second bottom panel along the fold line 60 so that the secondary male locking flaps 58a, 58b extend generally upwardly. Once the primary male locking flaps 54 are engaged with the female locking edges 53, the secondary male locking flaps 58a, 58b are respectively inserted through, and cooperatively interact with, the respective slits 56a, 56b to further secure the second bottom panel 34 to the first bottom panel 26. The interlocked bottom panels 26, 34 cooperate to form a bottom panel 140 of the carrier 5.

**[0034]** The ends 6, 8 of the carton 5 can be closed (not shown) by overlapping the end flaps 126, 130 at the first end 6 and adhering the end flap 130 to the end flap 126 (e.g., at glue lines, glue tabs, or other suitable features), and by overlapping the end flaps 128, 132 at the second end 8 and adhering the end flap 132 to the end flap 128 (e.g., at glue lines, glue tabs, or other suitable features). The carton 5 could be formed with alternative forming steps without departing from the disclosure.

[0035] In the illustrated embodiment, the engagement of the folded retention tabs 68, 84 with the recesses R of the containers C can help prevent movement of the containers C within the carton 5 and can help prevent the containers C from being forced out of the carton 5. In addition, or alternatively, the engagement of the folded retention tabs 68, 84 with the recesses R of the containers C can help reduce damage to the carton 5 due to outside force applied to the carton. The carton 5 could be otherwise shaped, arranged, positioned, and/or configured without departing from the disclosure.

[0036] In general, the blanks according to the present disclosure can be constructed from paperboard having a caliper so that it is heavier and more rigid than ordinary paper. The blanks can also be constructed of other materials, such as cardboard, or any other material having properties suitable for enabling the carton to function at least generally as described above. The blanks can be coated with, for example, a clay coating. The clay coating may then be printed over with product, advertising, and other information or images. The blanks may then be coated with a varnish to protect information printed on the blanks. The blanks may also be coated with, for example, a moisture barrier layer, on either or both sides of the blanks. The blanks can also be laminated to or coated with one or more sheet-like materials at selected panels or panel sections.

[0037] In accordance with the exemplary embodiments, a fold line can be any substantially linear, although not necessarily straight, form of weakening that facilitates folding therealong. More specifically, but not for the purpose of narrowing the scope of the present disclosure, fold lines include: a score line, such as lines formed with a blunt scoring knife, or the like, which creates a crushed or depressed portion in the material along the desired line of weakness; a cut that extends partially into a material along the desired line of weakness, and/or a series of cuts that extend partially into and/or completely through the material along the desired line of weakness; and various combinations of these features. In situations where cutting is used to create a fold line, typically the cutting will not be overly extensive in a manner that might cause a reasonable user to incorrectly consider the fold line to be a tear line.

[0038] The above embodiments may be described as having one or more panels adhered together by glue during erection of the carton embodiments. The term “glue” is intended to encompass all manner of adhesives commonly used to secure carton panels in place.

[0039] The foregoing description of the disclosure illustrates and describes various exemplary embodiments. Various additions, modifications, changes, etc., could be made to the exemplary embodiments without departing from the spirit and scope of the disclosure. It is intended that all matter contained in the above description or shown in the accompanying drawings shall be interpreted as illustrative and not in a limiting sense. Additionally, the disclosure shows and

describes only selected embodiments of the disclosure, but the disclosure is capable of use in various other combinations, modifications, and environments and is capable of changes or modifications within the scope of the inventive concept as expressed herein, commensurate with the above teachings, and/or within the skill or knowledge of the relevant art. Furthermore, certain features and characteristics of each embodiment may be selectively interchanged and applied to other illustrated and non-illustrated embodiments of the disclosure.

## WHAT IS CLAIMED IS:

1. A carton for carrying a plurality of articles, the carton comprising  

a plurality of panels at least partially extending around an interior of the carton, the plurality of panels comprising a top panel, at least one side panel, and at least one bottom panel;

at least one retention tab foldably connected to the at least one bottom panel, the at least one retention tab being for engaging at least a portion of an article of the plurality of articles; and

at least one corner flap foldably connected to the at least one side panel, wherein each of the at least one retention tab and the at least one corner flap is disposed adjacent to at least one corner opening in the carton.
2. The carton of claim 1, wherein the at least one corner flap comprises a first corner flap and a second corner flap each foldably connected to the at least one side panel along a fold line adjacent the at least one corner opening.
3. The carton of claim 2, wherein the first corner flap and the second corner flap are separable from one another along a first cut line, and each of the first corner flap and the second corner flap is separable from the first side panel or the second side panel along a respective second cut line and third cut line.
4. The carton of claim 1, wherein the at least one retention tab is foldably connected to the at least one bottom panel along an arcuate fold line at a bottom end of the at least one corner opening, and the at least one corner flap is foldably connected to the at least one side panel along a fold line at an opposing end of the at least one corner opening.
5. The carton of claim 1, wherein the at least one side panel is foldably connected to the at least one bottom panel along a first fold line, a second fold line extends in the at least one side panel, and the at least one side panel comprises a bottom corner panel extending between the first fold line and the second fold line.
6. The carton of claim 5, wherein the at least one corner opening extends at least partially in the bottom corner panel.
7. The carton of claim 5, wherein the at least one retention tab is foldably connected to the at least one bottom panel along a third fold line, the at least one corner flap is foldably connected to the at least one side panel along a fourth fold line, and at least a portion of each of the third fold line and the fourth fold line is spaced apart from each of the first fold line and the second fold line.

8. The carton of claim 1, wherein the at least one retention tab is folded generally upwardly from the at least one bottom panel to engage a recess of the article and the at least one corner flap is for engaging a side of the article at least partially received in the at least one corner opening.
9. The carton of claim 1, wherein the at least one retention tab and the at least one corner flap are generally aligned with at least one locking feature in the at least one bottom panel.
10. The carton of claim 1, wherein the at least one side panel comprises a first side panel and a second side panel, the at least one bottom panel comprises a first bottom panel and a second bottom panel foldably connected to the respective first side panel and second side panel, the at least one retention tab comprises at least one first retention tab foldably connected to the first bottom panel and at least one second retention tab foldably connected to the second bottom panel, and the at least one corner flap comprises at least one first corner flap foldably connected to the first side panel and at least one second corner flap foldably connected to the second side panel.
11. The carton of claim 10, wherein the at least one corner opening comprises at least one first corner opening and at least one second corner opening each for at least partially receiving a portion of the article.
12. The carton of claim 11, wherein the at least one first retention tab and the at least one first corner flap are adjacent the at least one first corner opening, and the at least one second retention tab and the at least one second corner flap are adjacent the at least one second corner opening.
13. The carton of claim 10, wherein the first bottom panel and the second bottom panel are foldably connected to the respective first side panel and second side panel along respective longitudinal fold lines, at least one first bottom locking feature is disposed in the first bottom panel, at least one second bottom locking feature is disposed in the second bottom panel, and the at least one first retention tab, the at least one first bottom locking feature, the at least one second retention tab, and the at least one second bottom locking feature are generally aligned along a lateral direction.
14. The carton of claim 1, further comprising at least two top corner flaps foldably connected to the at least one side panel adjacent a top corner opening for at least partially receiving a top portion of the article, the top corner opening being adjacent the top panel.
15. The carton of claim 14, wherein the at least one bottom panel is foldably connected to the at least one side panel along a first longitudinal fold line, the at least one side panel is foldably connected to the at top panel along a second longitudinal fold line, and the at least one retention tab, the at least

one corner opening, and the at least one top corner opening are generally aligned in a lateral direction.

16. The carton of claim 1, further comprising at least one end flap foldably connected to the at least one side panel for at least partially closing an end of the carton.

17. A blank for forming a carton for holding a plurality of articles, the blank comprising:

a plurality of panels comprising a top panel, at least one side panel, and at least one bottom panel;

at least one retention tab foldably connected to the at least one bottom panel; and

at least one corner flap foldably connected to the at least one side panel, the at least one retention tab being at least partially separable from the at least one corner flap along at least one cut line for forming at least one corner opening in the carton formed from the blank.

18. The blank of claim 17, wherein the at least one corner flap comprises a first corner flap and a second corner flap each foldably connected to the at least one side panel along a fold line.

19. The blank of claim 18, wherein the first corner flap and the second corner flap are separable from one another along a first cut line, and each of the first corner flap and the second corner flap is separable from the first side panel or the second side panel along a respective second cut line and third cut line.

20. The blank of claim 17, wherein the at least one retention tab is foldably connected to the at least one bottom panel along an arcuate fold line at a bottom end of the at least one corner opening when the carton is formed from the blank, and the at least one corner flap is foldably connected to the at least one side panel along a fold line at an opposing end of the at least one corner opening when the carton is formed from the blank.

21. The blank of claim 17, wherein the at least one side panel is foldably connected to the at least one bottom panel along a first fold line, a second fold line extends in the at least one side panel, and the at least one side panel comprises a bottom corner panel extending between the first fold line and the second fold line.

22. The blank of claim 21, wherein the at least one corner flap extends at least partially in the bottom corner panel.

23. The blank of claim 21, wherein the at least one retention tab is foldably connected to the at least one bottom panel along a third fold line, the at least one corner flap is foldably connected to the at least one side panel along a fourth fold line, and at least a portion of each of the third fold line and the fourth fold line is spaced apart from each of the first fold line and the second fold line.

24. The blank of claim 17, wherein the at least one retention tab and the at least one corner flap are generally aligned with at least one locking feature in the at least one bottom panel.

25. The blank of claim 17, wherein the at least one side panel comprises a first side panel and a second side panel, the at least one bottom panel comprises a first bottom panel and a second bottom panel foldably connected to the respective first side panel and second side panel, the at least one retention tab comprises at least one first retention tab foldably connected to the first bottom panel and at least one second retention tab foldably connected to the second bottom panel, and the at least one corner flap comprises at least one first corner flap foldably connected to the first side panel and at least one second corner flap foldably connected to the second side panel.

26. The blank of claim 25, wherein the first bottom panel and the second bottom panel are foldably connected to the respective first side panel and second side panel along respective longitudinal fold lines, at least one first bottom locking feature is disposed in the first bottom panel, at least one second bottom locking feature is disposed in the second bottom panel, and the at least one first retention tab, the at least one first bottom locking feature, the at least one second retention tab, and the at least one second bottom locking feature are generally aligned along a lateral direction.

27. The blank of claim 17, further comprising at least two top corner flaps foldably connected to the at least one side panel adjacent a top corner opening for at least partially receiving a top portion of the article, the top corner opening being adjacent the top panel.

28. The blank of claim 27, wherein the at least one bottom panel is foldably connected to the at least one side panel along a first longitudinal fold line, the at least one side panel is foldably connected to the at top panel along a second longitudinal fold line, and the at least one retention tab and the at least one top corner opening are generally aligned in a lateral direction.

29. The blank of claim 17, further comprising at least one end flap foldably connected to the at least one side panel for at least partially closing an end of the carton formed from the blank.

30. A method of forming a carton for holding a plurality of articles, comprising:

obtaining a blank comprising a plurality of panels comprising a top panel, at least one side panel, and at least one bottom panel, at least one retention tab foldably connected to the at least one



bottom panel, and at least one corner flap foldably connected to the at least one side panel, the at least one retention tab being at least partially separable from the at least one corner flap along at least one cut line;

forming an interior of the carton at least partially defined by the plurality of panels, the forming the interior comprising folding the at least one bottom panel with respect to the at least one side panel; and

at least partially engaging the at least one retention tab with a bottom portion of an article of the plurality of articles, the engaging the at least one retention tab at least partially forming a corner opening in the carton.

31. The method of claim 30, wherein the forming the interior of the carton comprises folding the at least one bottom panel outwardly with respect to the at least one side panel prior to the engaging the at least one retention tab and folding the at least one bottom panel inwardly with respect to the at least one side panel after the engaging the at least one retention tab.

32. The method of claim 31, wherein the folding the at least one bottom panel outwardly at least partially separates the at least one retention tab from the at least one corner flap, and the folding the at least one bottom panel inwardly at least partially inserts the at least one retention tab into a recess in the bottom portion of the article.

33. The method of claim 30, wherein:

the at least one side panel comprises a first side panel and a second side panel, the at least one bottom panel comprises a first bottom panel and a second bottom panel foldably connected to the respective first side panel and second side panel, and the at least one retention tab comprises at least one first retention tab foldably connected to the first bottom panel and at least one second retention tab foldably connected to the second bottom panel; and

the forming the interior of the carton comprises folding the first bottom panel and the second bottom panel outwardly with respect to the respective first side panel and second side panel prior to the engaging the at least one retention tab, folding the first bottom panel inwardly with respect to the first side panel after the engaging the at least one retention tab, and then folding the second bottom panel inwardly with respect to the second side panel after the engaging the at least one retention tab.

34. The method of claim 33, wherein the folding the first bottom panel and the second bottom panel outwardly at least partially separates the at least one first retention tab and the at least one second retention tab from the respective first bottom panel and second bottom panel, the folding the first bottom panel inwardly at least partially inserts the at least one first retention tab into a recess in the bottom portion of the article, and the folding the second bottom panel inwardly at least partially inserts the at least one second retention tab into the recess in the bottom portion of the article.

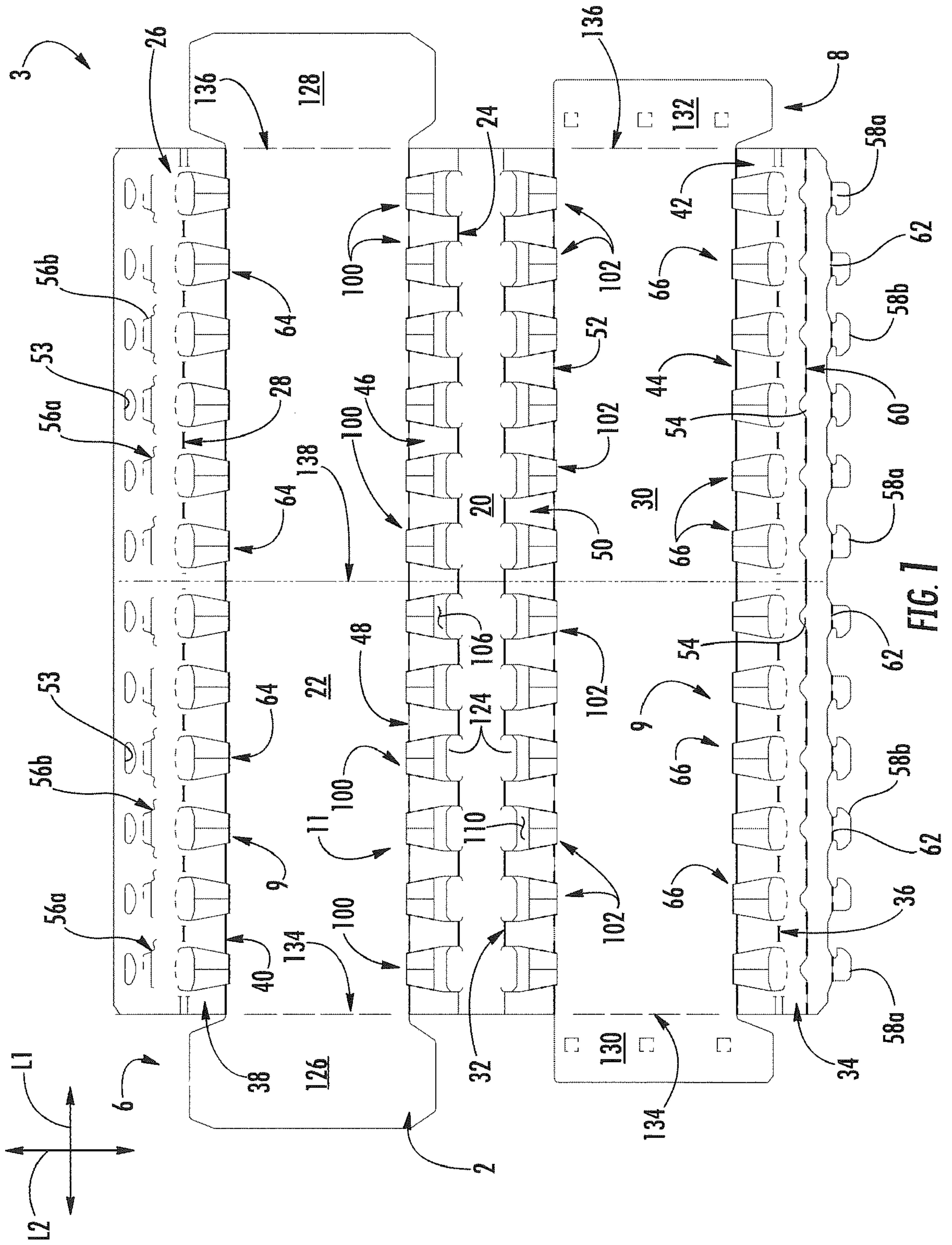

FIG. 1

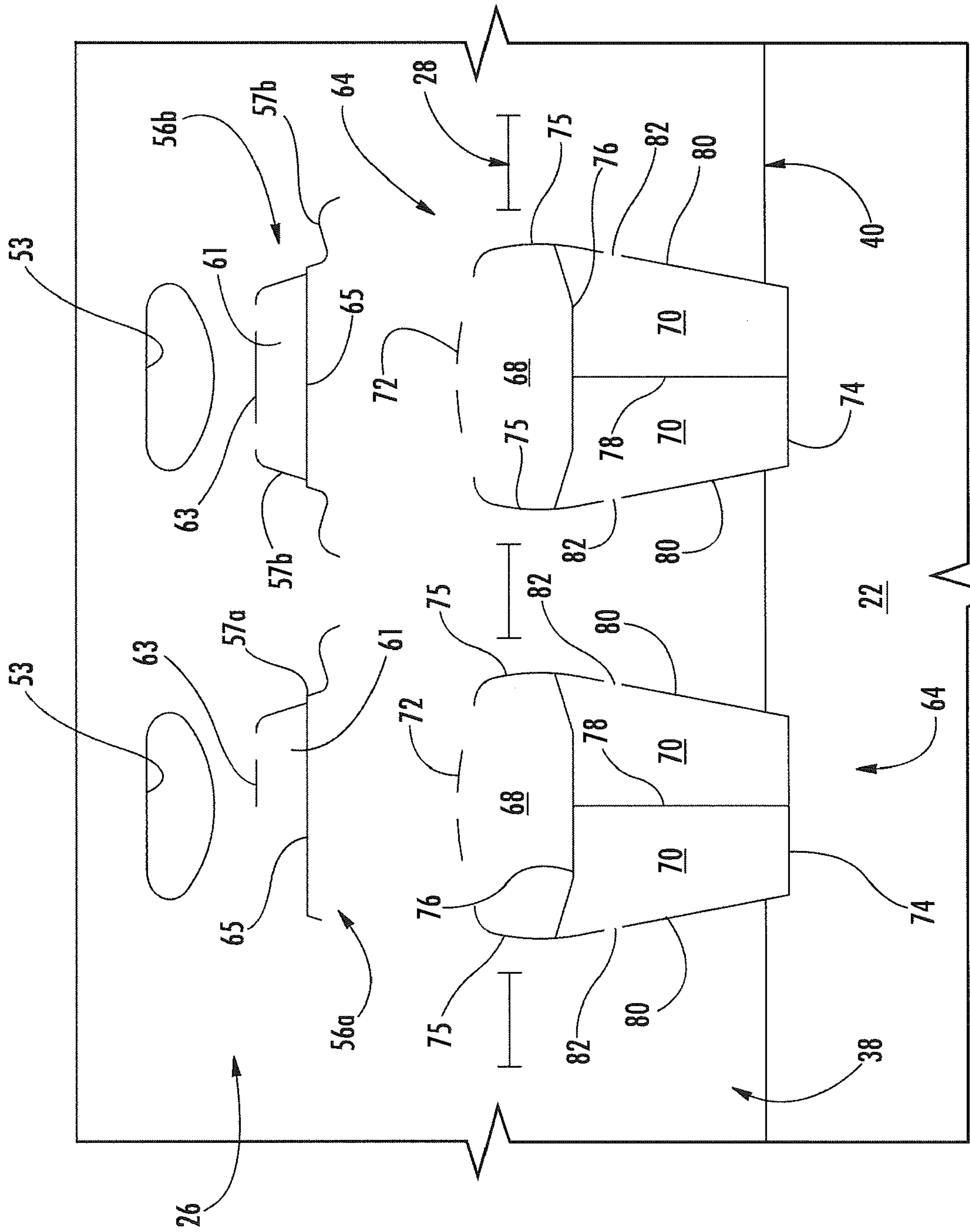

FIG. 2A

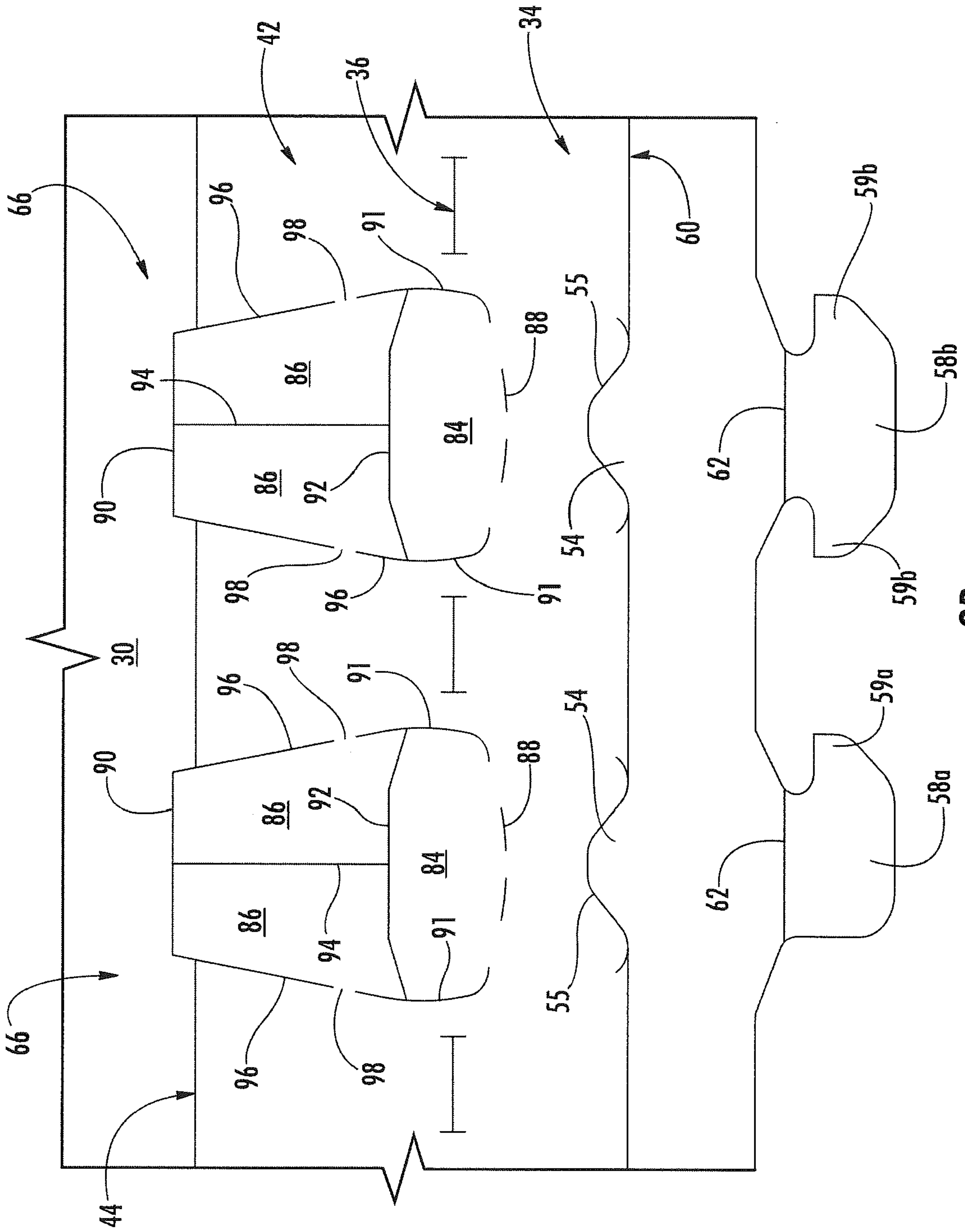

FIG. 2B

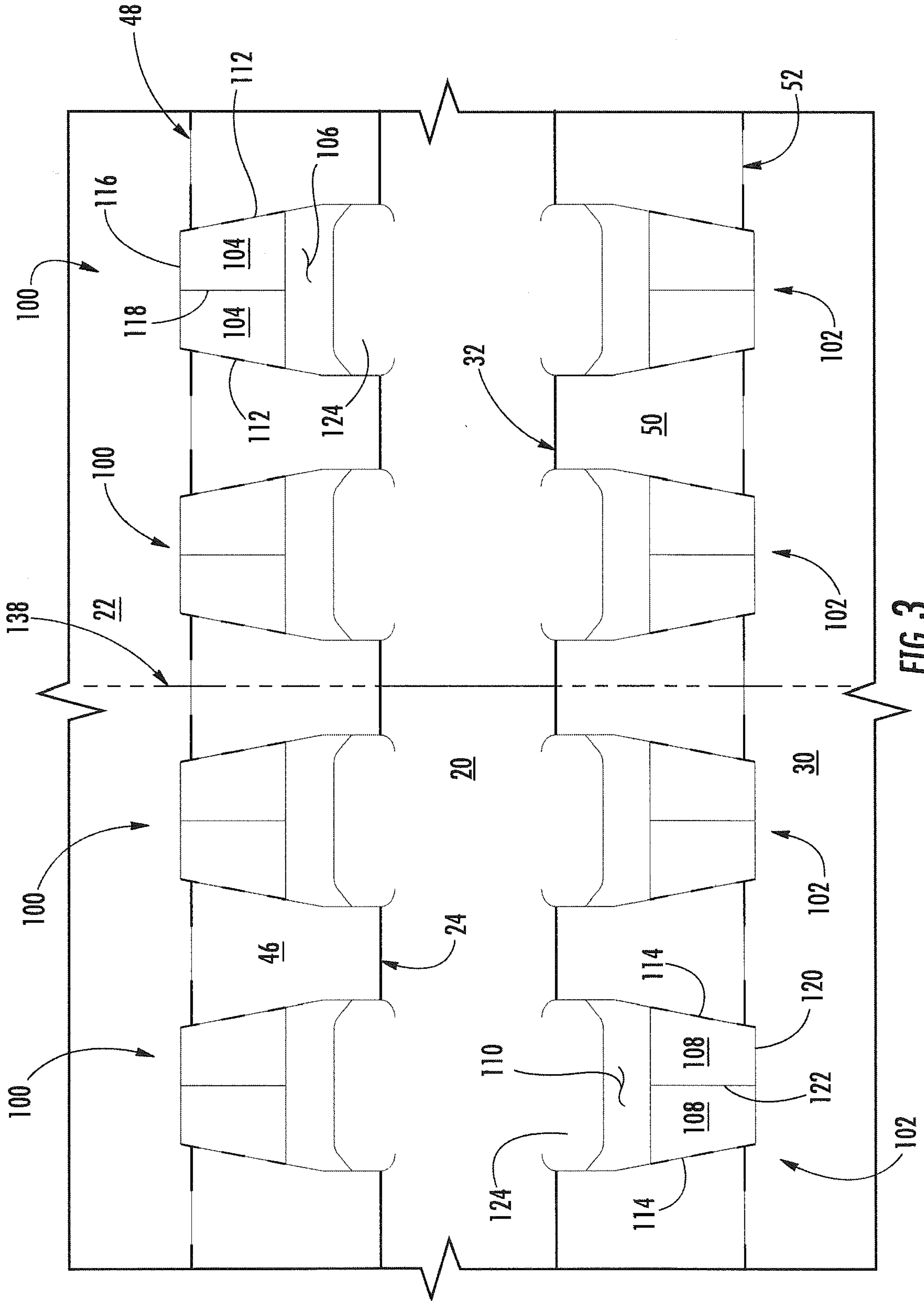

FIG. 3

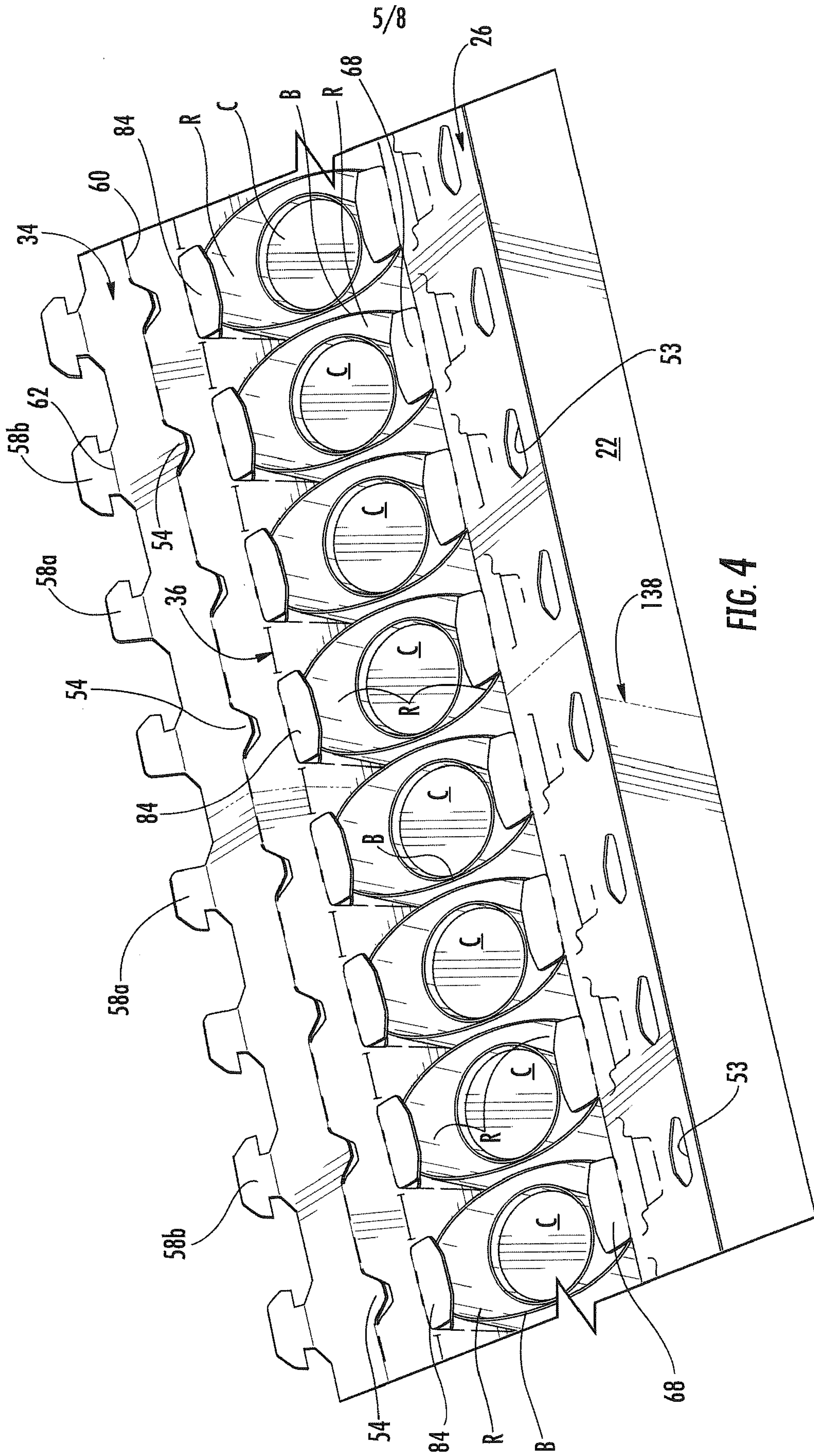

FIG. 4

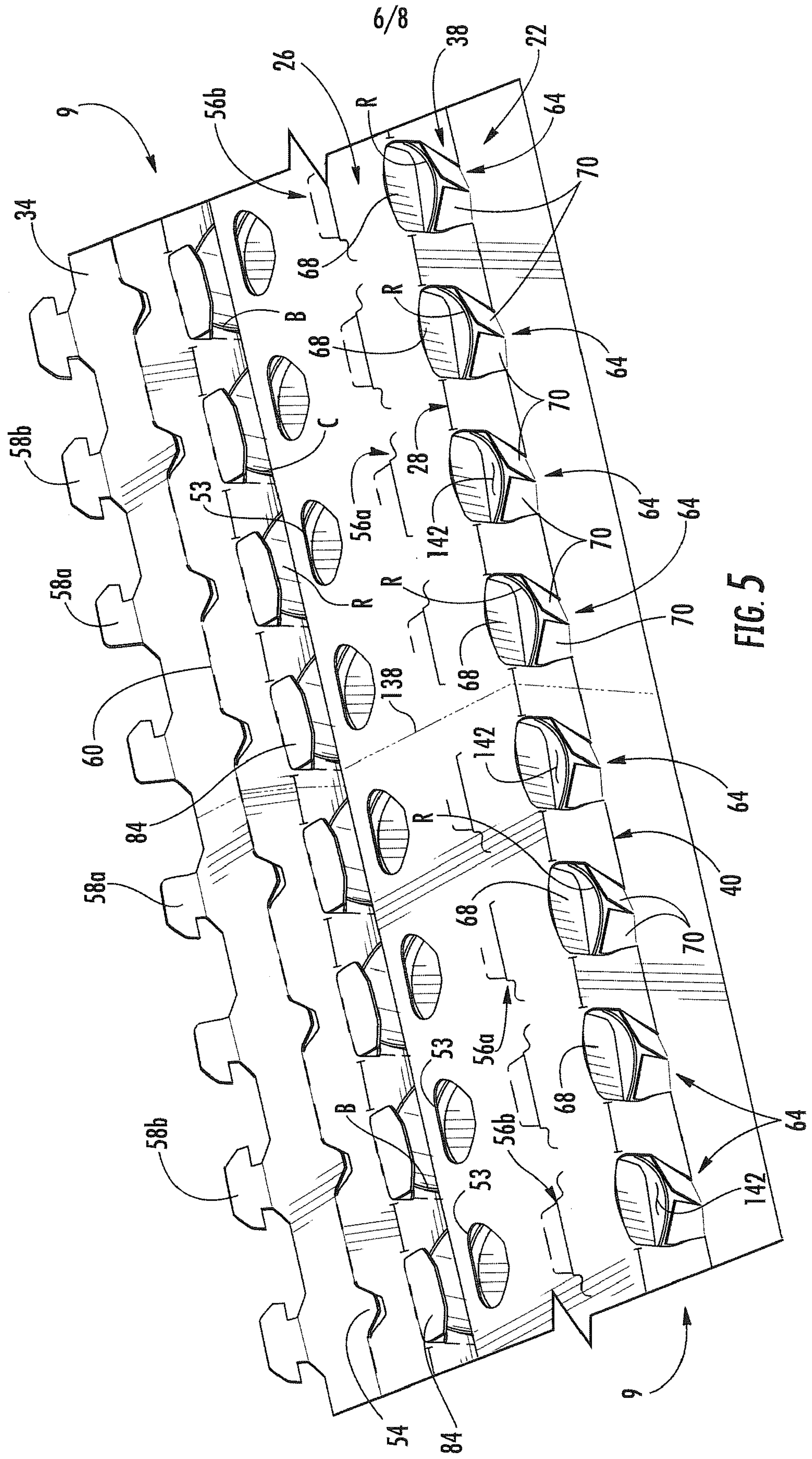
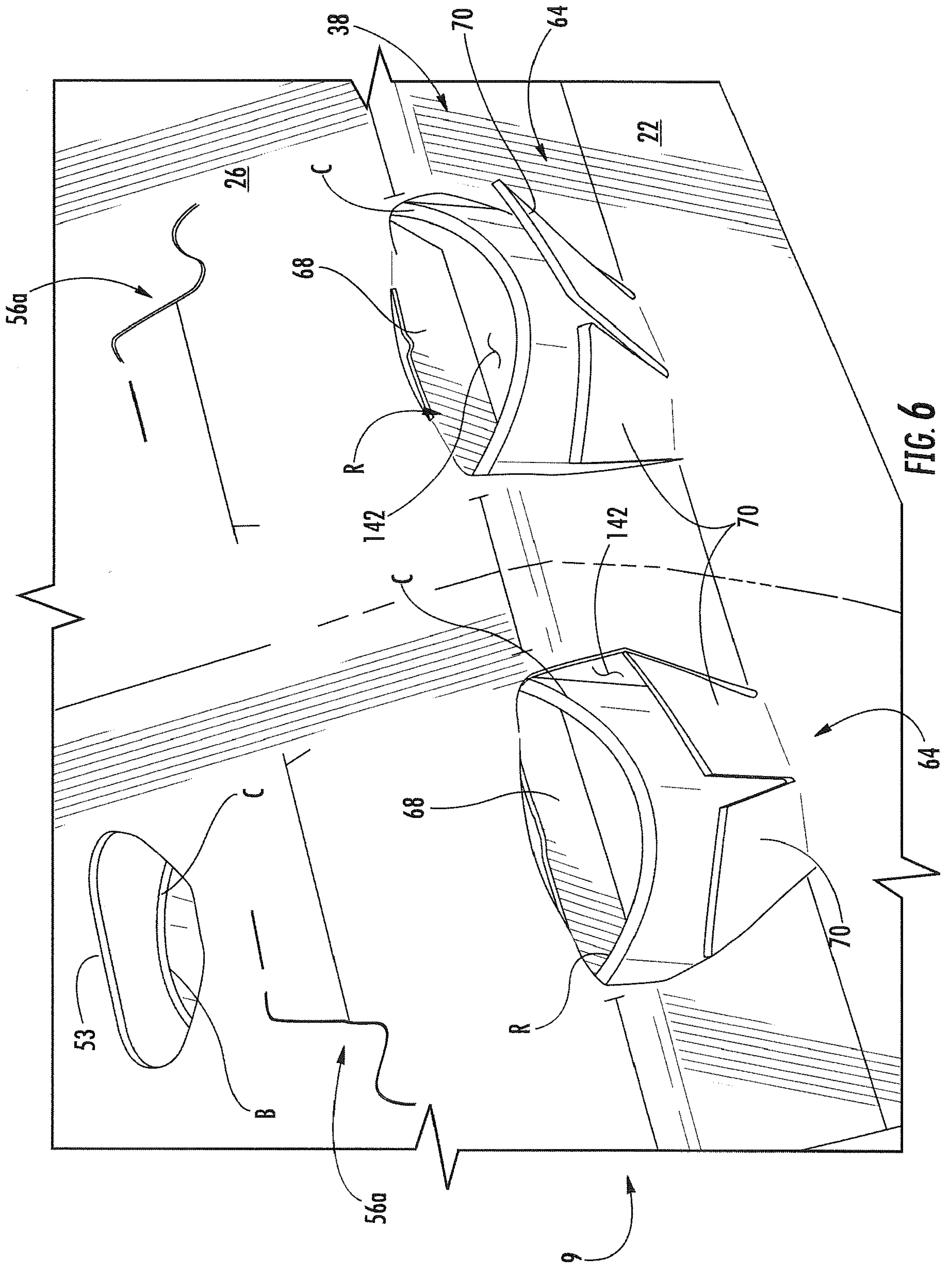

FIG. 5



7/8



8/8

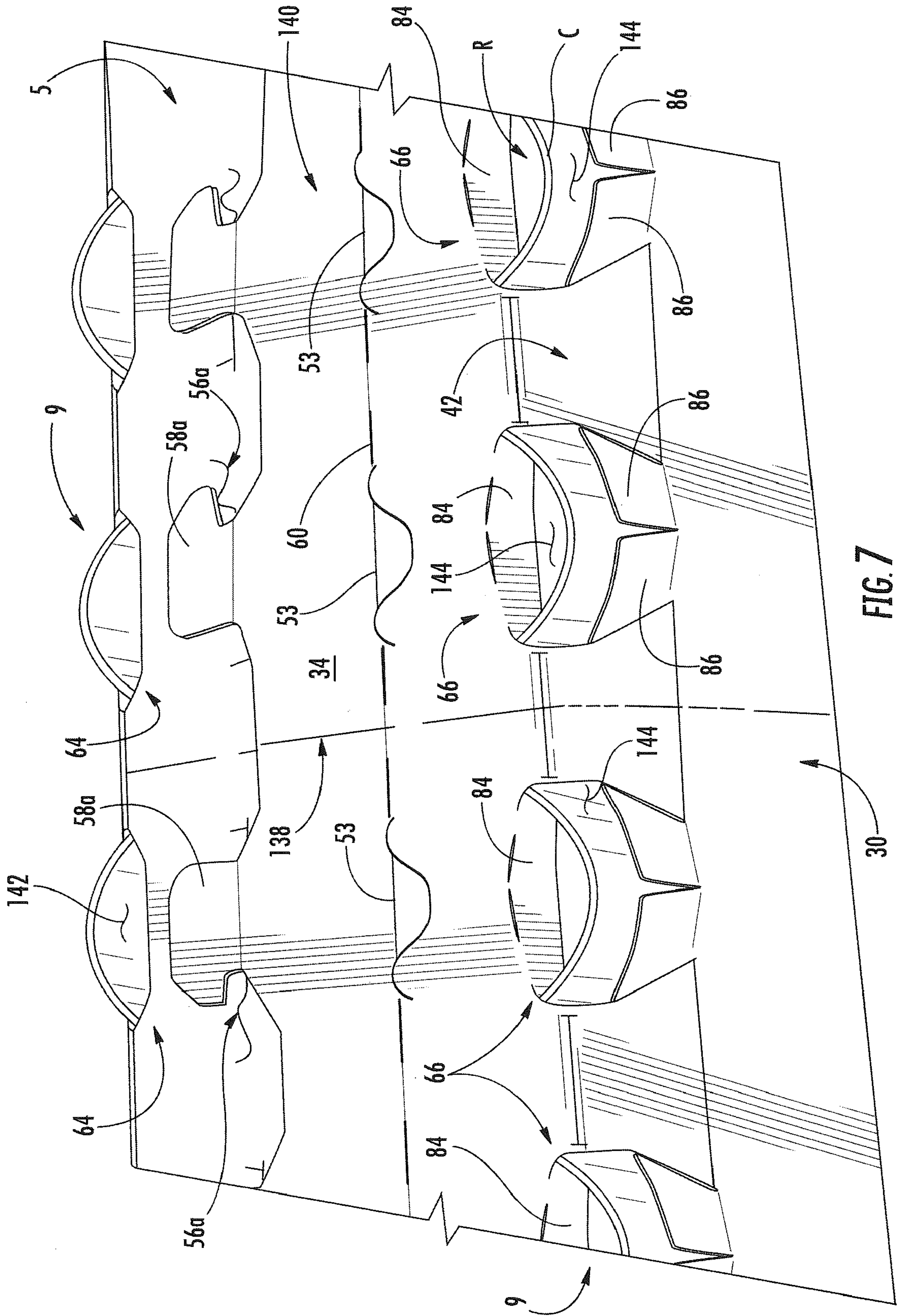
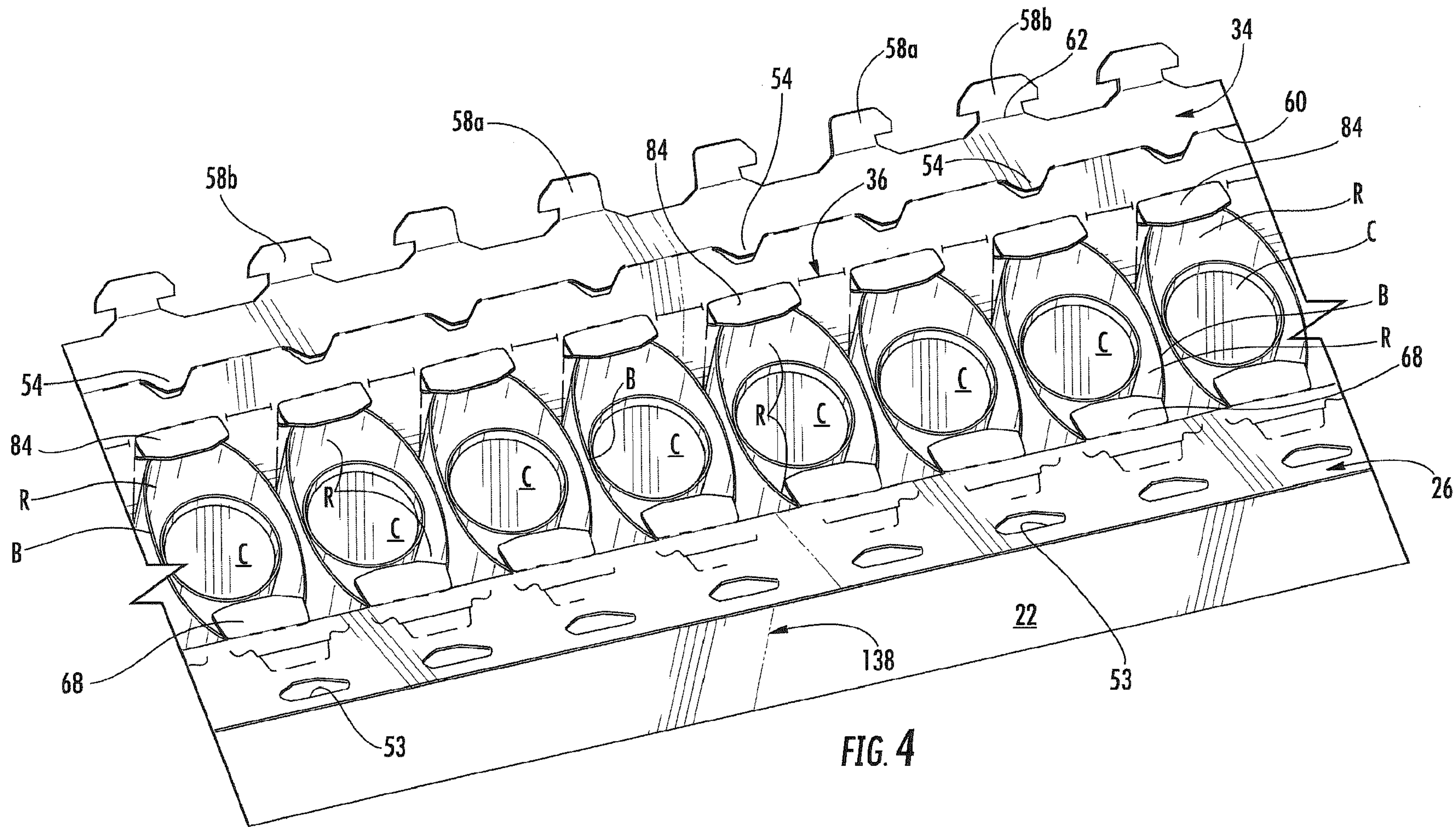

FIG. 7



**FIG. 4**