

(19) World Intellectual Property Organization
International Bureau



(43) International Publication Date
20 April 2006 (20.04.2006)

PCT

(10) International Publication Number
WO 2006/042106 A1

- (51) International Patent Classification:
H02M 1/00 (2006.01) H02K 53/00 (2006.01)
- (21) International Application Number:
PCT/US2005/036131
- (22) International Filing Date: 5 October 2005 (05.10.2005)
- (25) Filing Language: English
- (26) Publication Language: English
- (30) Priority Data:
10/959,457 5 October 2004 (05.10.2004) US
- (71) Applicant (for all designated States except US): META-C CORPORATION [US/US]; 1002 Campbell Drive, Athens, Georgia 30605 (US).
- (72) Inventors; and
- (75) Inventors/Applicants (for US only): DINNAN, James A. [US/US]; 1002 Campbell Drive, Athens, GA 30605 (US). HERNANDEZ, Patrick [US/US]; 7613 Center Parkway, Sacramento, CA 95823 (US). DINNAN, Joseph A. [US/US]; 4220 Gailey Circle, Cameron Park, CA 95682 (US).
- (74) Agents: BERNSTEIN, Frank, L. et al.; KENYON & KENYON, 333 W. San Carlos Street, Suite 600, San Jose, CA 95110 (US).

- (81) Designated States (unless otherwise indicated, for every kind of national protection available): AE, AG, AL, AM, AT, AU, AZ, BA, BB, BG, BR, BW, BY, BZ, CA, CH, CN, CO, CR, CU, CZ, DE, DK, DM, DZ, EC, EE, EG, ES, FI, GB, GD, GE, GH, GM, HR, HU, ID, IL, IN, IS, JP, KE, KG, KM, KP, KR, KZ, LC, LK, LR, LS, LT, LU, LV, LY, MA, MD, MG, MK, MN, MW, MX, MZ, NA, NG, NI, NO, NZ, OM, PG, PH, PL, PT, RO, RU, SC, SD, SE, SG, SK, SL, SM, SY, TJ, TM, TN, TR, TT, TZ, UA, UG, US, UZ, VC, VN, YU, ZA, ZM, ZW.
- (84) Designated States (unless otherwise indicated, for every kind of regional protection available): ARIPO (BW, GH, GM, KE, LS, MW, MZ, NA, SD, SL, SZ, TZ, UG, ZM, ZW), Eurasian (AM, AZ, BY, KG, KZ, MD, RU, TJ, TM), European (AT, BE, BG, CH, CY, CZ, DE, DK, EE, ES, FI, FR, GB, GR, HU, IE, IS, IT, LT, LU, LV, MC, NL, PL, PT, RO, SE, SI, SK, TR), OAPI (BF, BJ, CF, CG, CI, CM, GA, GN, GQ, GW, ML, MR, NE, SN, TD, TG).

- Published:**
- with international search report
 - before the expiration of the time limit for amending the claims and to be republished in the event of receipt of amendments

For two-letter codes and other abbreviations, refer to the "Guidance Notes on Codes and Abbreviations" appearing at the beginning of each regular issue of the PCT Gazette.

(54) Title: DC/AC/ MOTOR/GENERATOR UTILIZING A PERIODIC TRANSFORMATION SYSTEM

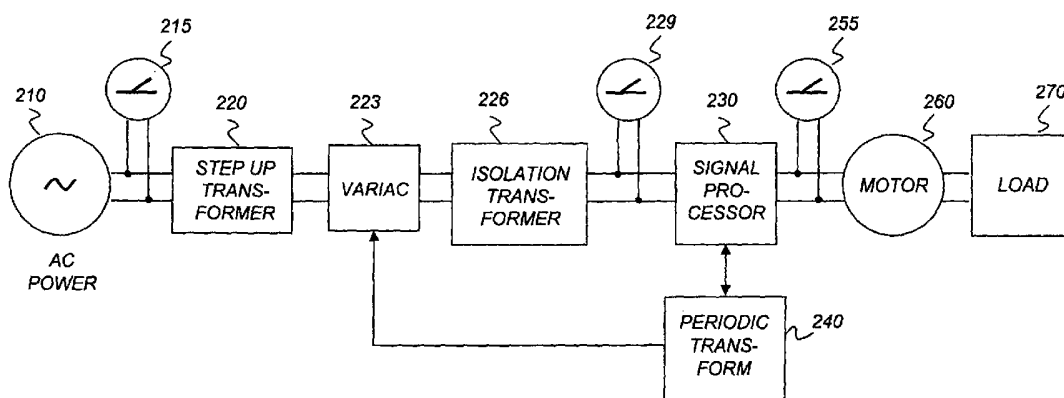

(57) Abstract: In an AC or DC motor operation and power generation system, a periodic transformation system reduces or prevents harmonic distortion, reduces resistance or impedance, and improves energy efficiency in a signal either consumed, such as in a motor, or produced, such as in a generator. In one embodiment, the TruScale Reactance Transformation System or the Eastern Modified TruScale Octave Transformation System are the periodic transform systems provided to prevent overtone collisions in current and voltage signals, in order to maximize energy spectral density, and to precondition either DC or AC signals.

WO 2006/042106 A1

DC/AC/ MOTOR/GENERATOR UTILIZING A PERIODIC TRANSFORMATION SYSTEM

FIELD OF THE INVENTION

[01] The present invention relates to improvements in direct current (DC) and alternating current (AC) motors and generators. More specifically, the invention relates to the treatment of electrical resonance in DC and AC motors and generators. Even more specifically, the invention relates to the use of a periodic transformation system known as TruScale to reduce collisions in voltage signals.

BACKGROUND OF THE INVENTION

[02] There have been various attempts over the years to apply signal processing techniques to improve performance of DC and AC motors and generators. Among other things, such efforts have been directed toward the improvement of power factor, one definition of which is the ratio of real power to apparent power. USP 6,670,783 and 6,674,205 provide examples of power factor improvements. Other approaches to the use of signal processing to improve power factor include USP 5,994,869.

[03] One important aspect of power factor is the amount of impedance which an AC system has, or resistance that a DC system has. One cause of impedance or resistance is phase cancellation, which can occur when two or more complex waveform components collide with each other. Such collisions can result from different phase values which are present at the same time. Such collisions result in destructive interference which manifests itself as impedance and/or resistance within a waveform.

[04] The inventors have conducted tests to determine the nature of phase cancellation, and have identified data pointing toward a consistent relationship found in phase cancellation. When the various internal components work against each other at a constant rate within a

given time interval, it will be seen that the phase cancellation relationships will be relatively consistent. It would be desirable to employ signal processing techniques to use this phase cancellation relationship information to eliminate destructive interference, thereby reducing impedance and improving power factor.

[05] Electrical resonance in both series and parallel form are known. The use of resonance in power systems has been limited, primarily because resonance has been viewed as producing negative and undesirable effects on power systems and appliances. USP 6,144,181 and 6,107,707 provide examples of techniques for reducing or eliminating resonance in electrical systems.

[06] The techniques described in these patents are possible, in part, because resonant states of motors and generators can be determined through any number of means, including audio, video, tactile, electrical, or mechanical. Such calculations and determinations are well within the ability of ordinarily skilled artisans, and need not be detailed here.

[07] According to investigations that the inventors have undertaken, while it appears that attempts have been made to use resonance characteristics advantageously in areas such as radio modulation and audio, in power systems precisely the opposite approach has been taken, as witnessed by the numerous attempts to reduce or eliminate resonance. From what the inventors have been able to determine, the transient nature of resonance has led to the perception that resonance is undesirable in power generation and transmission systems. Resonance has led to power spikes, which can be damaging to electrical equipment.

[08] Because there are efficiencies to be obtained from the power levels resulting from resonance, it would be desirable to determine how to make resonance a persistent, rather than a transient phenomenon.

SUMMARY OF THE INVENTION

[09] In view of the foregoing, it is one object of the present invention to generate phase cancellation data to eliminate destructive interference, and thereby improve power factor in motor and generator systems. In one aspect, the present invention uses such phase cancellation data to redistribute component signal energy into constructive groupings, rather than destructive groupings.

[10] In one aspect, the present invention addresses the problem of destructive interference and impedance by a novel use of resonance, which others have tried to eliminate, to augment efficiency in DC and AC motor and generator systems. The invention utilizes electrical resonance, in both series and parallel form, to improve energy utilization throughout motor and/or generator systems. Rather than treating electrical resonance as a transient phenomenon to be reduced or eliminated, the inventive approach seeks to extend the persistence of the resonance phenomenon. By calculating or determining the resonant state of the motor and/or generator system in any of a number of known ways as mentioned above, and building the power circuitry in order to utilize the effective average and peak power increase and decreased impedance and/or resistance associated with the resonant state, the present invention is able to utilize the resonant effect to reduce impedance and/or resistance with a given input signal and subsequent usage of the signal in DC or AC motor and/or generator systems.

[11] In a more specific implementation, the present invention uses a periodic transformation system to reduce or prevent harmonic distortion, reduce resistance and/or impedance, and optimize energy efficiency in signals either that are consumed, such as in a motor, or produced, such as in a generator. In one embodiment, the invention uses a periodic transformation system such as the TruScale Reactance Transformation System, and in one further embodiment, the Eastern Modified TruScale Octave Transformation System, to

prevent overtone collisions. Various aspects of the TruScale Octave Transformation System have been disclosed in commonly assigned patents, including USP 4,860,624 and 5,306,865, the disclosures of which are incorporated by reference here. Other commonly assigned patents disclose and teach other uses of TruScale in signal processing, including USP 6,003,000, 6,178,316, and 6,415,253, all of which also are incorporated by reference herein.

BRIEF DESCRIPTION OF THE DRAWINGS

[12] The present invention now will be described in detail with respect to certain embodiments, and with reference to the accompanying drawings, in which:

[13] FIG. 1A is a block diagram of a system incorporating the signal processing techniques of the present invention;

[14] FIG. 1B is an oscilloscope capture of the present invention's waveform as compared to an unprocessed signal;

[15] FIG. 2A is a block diagram of a baseline test configuration used to show the power efficiency improvements that the present invention achieves;

[16] FIG. 2B is a more detailed version of FIG. 1, showing in a little more detail one embodiment of a variable transformer which may be used in accordance with the invention;

[17] FIG. 3 is a block diagram of yet another test configuration employing the signal processing techniques of the present invention; and

[18] FIG. 4 shows a circuit implementation of the invention for a three-phase motor.

DETAILED DESCRIPTION OF PREFERRED EMBODIMENTS

[19] In FIG. 1A, an AC power source 110, such as a wall outlet or, in larger scale configurations, power provided directly from a commercial or other power source, provides current to variable isolation transformer 120, the output of which passes through signal processor 130 to motor 160, which in turn powers a load 170. The intervening signal

processor 130 employs signal processing techniques including application of a periodic transform in accordance with the invention. The periodic transform is shown as a separate block 140 in FIG. 1A, but could be included in signal processor 130 if desired. A line is shown from periodic transform block 140 back to variable isolation transformer 120, to show how, in one embodiment, current draw through the transformer may be reduced in accordance with the invention, while preserving desired power output. In addition, while signal processing block 130 and periodic transform 140 are shown separate from motor 160, motor 160 could include these blocks as part of an overall unit for powering a load.

[20] In the course of their research, the inventors have analyzed a relationship between inductive reactance and capacitive reactance of a signal, and have noted an inverse relationship, which results from a phase difference which occurs between the voltage and the current of any signal. It is possible to depict on a unit circle a relationship between the degree of phase offset relative to zero phase (or complete coherence) and resistance and/or impedance in the signal. For each degree of phase inter-modulation offset, there is a corresponding increase in the resistance or impedance which is inherent in any signal. There is always a certain amount of inductance or capacitance, irrespective of whether explicit inductors or capacitors are used in a given circuit. Issues of inductive reactance and capacitive reactance are important, because the inventors have appreciated that the differences realized between apparent power and true power (and hence in power factor) using conventional methods of power production and utilization result from these differences in phase, caused by inaccurate calculation of and compensation for signal reactances.

[21] The following table provides a set of inductive reactance and capacitive reactance values, and intervals which includes one embodiment of the Tru-Scale Octave Transformation System. It should be noted that this table reflects only a limited number of

octaves in this embodiment of Tru-Scale. The table can be extrapolated upwardly and downwardly to yield additional values.

TRUSCALE REACTANCE TRANSFORMATION SYSTEM

TABLE 1

Capacitive Reactance	Interval	Inductive Reactance	Interval
1.171875		1.171875	
1.21875	0.046875	1.220703125	0.048828125
1.265625	0.046875	1.26953125	0.048828125
1.3125	0.046875	1.318359375	0.048828125
1.359375	0.046875	1.3671875	0.048828125
1.40625	0.046875	1.416015625	0.048828125
1.453125	0.046875	1.46484375	0.048828125
1.5	0.046875	1.513671875	0.048828125
1.546875	0.046875	1.5625	0.048828125
1.59375	0.046875	1.611328125	0.048828125
1.640625	0.046875	1.66015625	0.048828125
1.6875	0.046875	1.708984375	0.048828125
1.734375	0.046875	1.7578125	0.048828125
			0
1.78125	0.046875	1.7578125	0.048828125
1.828125	0.046875	1.806640625	0.048828125
1.875	0.046875	1.85546875	0.048828125
1.921875	0.046875	1.904296875	0.048828125
1.96875	0.046875	1.953125	0.048828125
2.015625	0.046875	2.001953125	0.048828125
2.0625	0.046875	2.05078125	0.048828125
2.109375	0.046875	2.099609375	0.048828125
2.15625	0.046875	2.1484375	0.048828125
2.203125	0.046875	2.197265625	0.048828125
2.25	0.046875	2.24609375	0.048828125
2.296875	0.046875	2.294921875	0.048828125
2.34375		2.34375	

[22] A similar table is possible, using the following Modified Eastern Tru-Scale Octave Transformation System: Again, it should be noted that this table reflects only a limited number of octaves in this embodiment of Tru-Scale. The table can be extrapolated upwardly and downwardly to yield additional values.

Interval	Capacitive Reactance Frequency	Ratios	Note	Inductive Reactance Frequency	Interval
12	300	1:1	C.sup.0	300	12.5
12	312	25:24	C.music-sharp.	312.5	12.5
12	324	13:12	D.sup..music-flat.	325	12.5
12	335	9:8	D	337.5	12.5
12	348	7:6	D.music-sharp.	350	12.5
12	360	29:24	E.music-flat.	362.5	12.5
12	372	5:4	E	375	12.5
12	384	31:24	E.sup..music-sharp.	387.5	12.5
12	396	4:3	F.sup..music-flat.	400	12.5
12	408	11:8	F	412.5	12.5
12	420	17:12	F.sup..music-sharp.	425	12.5
12	432	35:24	G.sup..sup..music-flat.	437.5	12.5
12	444	3:2	G	450	12.5
12	456	3:2	G	450	0
12	468	37:24	G.sup..music-sharp.	462.5	12.5
12	480	19:12	H.sup..sup..music-flat.	475	12.5
12	492	13:8	H	487.5	12.5
12	504	5:3	H.sup..music-sharp.	500	12.5
12	516	41:24	A.sup..sup..music-flat.	512.5	12.5
12	528	7:4	A	525	12.5
12	540	43:24	A.sup..music-sharp.	537.5	12.5
12	552	11:6	B.sup..sup..music-flat.	550	12.5
12	564	15:8	B	562.5	12.5
12	576	23:12	B.sup..music-sharp.	575	12.5
12	588	47:24	C.sup..sup..music-flat.	587.5	12.5
12	600	2:1	C.sup.1	600	

[23] AC and DC motors operate using sinusoidal waveforms to induce a magnetic field which moves the rotor of a motor in order to perform work. Conventionally, the sinusoidal waveforms applied are symmetrical. The magnetic field strength is determined in part by the speed at which current rises in the motor. The faster that current rises in that signal, the more realized power may be available from the motor utilizing the signal. In accordance with the present invention, the upslope of the sinusoidal waveform is accelerated going from zero to maximum, and also (in a negative sense) from zero to minimum. FIG. 1B is an oscilloscope capture of the waveform that the present invention yields, as compared to an unprocessed signal. As shown, the present invention has greater amplitude and concurrent average power

as compared to the unprocessed signal. In addition, the present invention's waveform, while non sinusoidal in nature, because of the use of a non averaging transform (such as TruScale in one embodiment), still can be consumed by devices such as motors that are currently using the average sinusoidal waveform model.

[24] The inventors have conducted tests, including tests of the following two types. In a first type of test, the load is a water pump. The results of the invention are measured according to the increase in pumping rate for a given amount of voltage input, or in the same or roughly the same amount of work being performed for a decreased amount of voltage.

The decrease in power input translates to reduced requirements off the power grid. In a second type of test, the load was a set of 1000 watt lamps in which a first amount of power was drawn from the grid to power the lamps, and then the invention was applied, still powering the lamps but with a greatly reduced power draw from the grid. As will be appreciated from these tests, the invention has applicability not only to the driving of electric motors (which in their broadest sense basically convert electrical energy to mechanical energy), but also to the operation of generators (which in their broadest sense basically convert mechanical energy to electrical energy). As used in motors, the invention reduces distortion in the input signals from the electrical source, be it a wall outlet or a larger power grid, to make the mechanical output of the motor more efficient. As used in generators, the invention reduces distortion in the output signals that provide electrical power, to make the power output more efficient, and enable the more efficient operation of electrical equipment.

[25] Looking now at FIG. 2A, showing a baseline test configuration, AC power source 210 is connected to step up transformer 220. A meter 215 measures current, voltage, and power characteristics coming out of the AC power source 210. The output of step up transformer 220 is provided to motor 260, and then to load 270. Meter 229 measures the output of the transformer going into the motor 260.

[26] In FIG. 2B, a more detailed version of the variable isolation transformer 120 from FIG. 1 is provided, in the form of step up transformer 220, variable AC transformer 223 (also known as a variac), and isolation transformer 226. Meters 215 and 229 are provided at spots corresponding to those in FIG. 2A. In FIG. 2B, signal processor block 230 is provided between isolation transformer 226 and motor 260. A further meter 255 is provided to show the output of signal processor 230 going to motor 260.

[27] As in the configuration of Fig. 1, here a reactance table, such as Table 1, in the periodic transform block 140 (Fig. 1) or 240 (Fig. 2B) provides contrasting associations between capacitance and inductance using corresponding values which reduce signal to noise ratios, thus providing a more harmonic relationship between the positive (inductance-related) and negative (capacitance-related) characteristics of the power source. In the interchange between periodic transform block 240 and signal processing block 230, the system can measure the characteristics of the circuit both before and after the imposition of the reactance table according to the periodic transform (in one embodiment, Tru-Scale), and can adjust the variac to provide optimum input to the overall circuit. More specifically, once the computed values of the capacitive and inductive relationships have been applied to the circuit, the power source (in this embodiment, a variac) can be increased or decreased, to provide greater or lesser torque depending upon the requirements of a work load. As a result, the same workload can be utilized with less power because of harmonic power relationships, or more torque can be provided for the same amount of power.

[28] It also should be noted that the power source is not critical to the invention. The source could be an AC wall outlet, or in larger applications, a commercial or other power grid, providing power from either a commercial electrical source, or wind-based, sun-based, nuclear-based, mechanically-based, fossil fuel-based, geothermally-based, hydrodynamically-based, or any other type of power source. What the invention does is to reduce distortion in

input electrical energy in order to enable more efficient driving of electrical equipment (a load). Whether the invention is placed at the input to a motor, between an electrical power source and the motor, or at the output of a generator, between the generator and a load, makes no difference.

[29] Table 2 shows the results of a test conducted using the configuration of FIG. 2A, where the load was a water pump. The test was conducted for one hour, and for an input from the AC power grid of 7.4 amps, 120.8 volts, 893.92 watts were generated (632 watts RMS). This is also the measured output at meter 229 after the output of step up transformer 220. The pump (load 270) was able to pump 3.0 gallons per minute, or 180 gallons of water in a one hour test, at a pressure of 5.5 psi.

TABLE 2

Readings at 215	Readings at 229	Performance (one hour)
7.4 amps	7.4 amps	3.0 gal per min
120.8 volts	120.8 volts	180 gals
893.92 watts	893.92 watts	5.5 PSI
632.00 watts RMS	632.00 watts RMS	

[30] Table 3 below shows results according to the invention using the configuration of FIG. 2B. At meter 215, power coming off the grid was shown to be 7.5 amps, 120.6 volts coming out of a wall outlet, for total power generation of 904.5 watts. Coming out of isolation transformer 229, there were 28.2 amps, 194 volts, and total power output of 5,470.8 watts (3867.85 watts RMS). This power output increase was achieved in accordance with the invention, in which periodic transformation from block 240 was applied to variac 223. At the output of signal processor block 230, meter 255 read the same results as at meter 229. The performance of the system resulted in 6.2 gallons per minute being pumped, for 186 gallons in a 30 minute test, at a pressure of 8.1 psi.

TABLE 3

Readings at 215	Readings at 229	Readings at 255	Performance (30 mins)
7.5 A	28.2 A	28.2 A	6.2 gal per min
120.6 V	194 V	194 V	186 gal
904.5 W	5470.8 W	5470.8 W	8.1 PSI
639.48 W RMS	3867.85 W RMS	3867.85 W RMS	

[31] In Table 4, the readings at meter 215 showed current of 7.5 amps, 54.5 volts, and 408.75 watts total output. The output at meter 229 was 15.6 amps, 160.0- volts, and 2496 watts. The output at meter 255 was 25.6 amps, 160.0 volts, and 2496 watts. Table 4 shows the results of tests employing this configuration. The results show significant output enhancement, even with reduced requirements off the power grid.

TABLE 4

Readings at 215	Readings at 229	Readings at 255	Performance (one hour)
7.5 A	15.6 A	15.6 A	2.5 gal per min
54.5 V	160.0 V	160.0 V	150 gallons
408.75 W	2496 W	2496 W	5.5 PSI
288.98 W RMS	1764.67 W RMS	1764.67 W RMS	

[32] In another set of tests, the configuration shown in FIG. 3 was provided, wherein the load was a pair of two 1,000 volt lamps. In order to power the lamps using this configuration, a generator 310 provides output to power a configuration similar to that of Fig. 2B, to drive a load 370 (the two 1,000 watt lamps). Table 5 shows the results of tests employing this configuration.

[33] In Table 5, the readings at meter 325 at the output of generator 310 showed current of 7.5 amps, 120 volts, and 900 watts total output (636.3 watts RMS). At meter 339 at the output of signal processor 330, meter 329 shows readings of 19.1 amps, 111 volts, and

2,120.1 watts (1498.90 watts RMS). The output at meter 360 after isolation transformer 350 was 18.6 amps, 101 volts, and 1,878.6 watts (1328.17 watts RMS).

TABLE 5

Readings at 325	Readings at 339	Readings at 360	Performance
7.5 A	19.1 A	18.6 A	
120 V	111 V	101 V	2 x 1000 W lamps
900.0 W	2120.1 W	1878.6 W	
636.3 W RMS	1498.90 W RMS	1328.17 W RMS	

[34] The signal processing accomplished in blocks 140, 240, and 340 employs exemplary inductive and capacitive reactance tables as shown above, using the periodic transformations in accordance with the invention, according to one embodiment. Any of the transforms disclosed in the above-referenced commonly-assigned patents may be used.

[35] In FIG. 4, showing a three-phase implementation of the invention for a three-phase motor 410 (which may be substituted for the motor 260 in Fig. 2A), the input wire for phase A is attached to the left terminal of a first capacitor C1, and another connection is made from a right terminal of capacitor C1 to a left terminal of capacitor C2. The input wire for phase B is attached to the left terminal of capacitor C2, and the other terminal of capacitor C2 is connected to a left terminal of capacitor C3. The input wire of phase C is attached to the left terminal of capacitor C3, and the other terminal of capacitor C3 is connected to the left terminal of capacitor C1.

[36] An output wire for phase A is connected from the left terminal of capacitor C1 to the phase A input of the motor. The output wire for phase B is connected from the left terminal of capacitor C2 to the phase B input of the motor. The output wire for phase C is connected from the left terminal of capacitor C3 to the phase C input of the motor.

[37] Test results using a motor configured as in Fig. 4 are as follows:

TABLE 6

Readings at 410 Baseline	Readings at 410 Three Phase Implementation	Work Performance 20.5 psi
462 V	462 V	
1.7 A	1.6 A	
552 W RMS @ watt meter 552 W per hour	185 W RMS @watt meter 185 W per hour	20.5 psi

[38] While the invention has been described in detail above with reference to preferred embodiments, various modifications within the scope and spirit of the invention will be apparent to ordinarily skilled artisans. As a result, the invention should be construed as limited only by the scope of the following claims.

WHAT IS CLAIMED IS:

1. A signal processing system comprising:
 - a. processing circuitry receiving input signals corresponding to power signals; and
 - b. periodic transformation circuitry communicating with said processing circuitry to communicate inductive capacitance and/or capacitive reactance values based on a predetermined periodic transformation system, so as to reduce distortion in the power signals;
 - c. said periodic transformation circuitry providing an output which can be used to control power draw requirements from a power source.

2. A system as claimed in claim 1, wherein the periodic transformation system comprises a TruScale Reactance Transformation System which includes the following table:

Capacitive Reactance	Interval	Inductive Reactance	Interval
1.171875		1.171875	
1.21875	0.046875	1.220703125	0.048828125
1.265625	0.046875	1.26953125	0.048828125
1.3125	0.046875	1.318359375	0.048828125
1.359375	0.046875	1.3671875	0.048828125
1.40625	0.046875	1.416015625	0.048828125
1.453125	0.046875	1.46484375	0.048828125
1.5	0.046875	1.513671875	0.048828125
1.546875	0.046875	1.5625	0.048828125
1.59375	0.046875	1.611328125	0.048828125
1.640625	0.046875	1.66015625	0.048828125
1.6875	0.046875	1.708984375	0.048828125
1.734375	0.046875	1.7578125	0.048828125
			0
1.78125	0.046875	1.7578125	0.048828125
1.828125	0.046875	1.806640625	0.048828125
1.875	0.046875	1.85546875	0.048828125
1.921875	0.046875	1.904296875	0.048828125
1.96875	0.046875	1.953125	0.048828125
2.015625	0.046875	2.001953125	0.048828125
2.0625	0.046875	2.05078125	0.048828125

Capacitive Reactance	Interval	Inductive Reactance	Interval
2.109375	0.046875	2.099609375	0.048828125
2.15625	0.046875	2.1484375	0.048828125
2.203125	0.046875	2.197265625	0.048828125
2.25	0.046875	2.24609375	0.048828125
2.296875	0.046875	2.294921875	0.048828125
2.34375		2.34375	

3. A system as claimed in claim 1, wherein said processing circuitry calculates resistance within an incoming DC signal, and uses said predetermined periodic transformation system to process said DC signal to reduce resistance therein.

4. A system as claimed in claim 1, wherein said processing circuitry calculates resistance/impedance in an input AC signal, and uses said predetermined periodic transformation system to process said AC signal to reduce resistance/impedance therein.

5. A system as claimed in claim 1, wherein said processing circuitry performs phase coherence in accordance with said periodic transformation system.

6. In a motor for converting electrical energy into another form of energy, the improvement comprising the system according to claim 1, receiving either DC or AC power from a power source and compensating for phase differences in current and voltage signals therein.

7. A motor as claimed in claim 6, wherein said motor is a three-phase AC motor.

8. A motor as claimed in claim 6, wherein the periodic transformation system comprises a TruScale Reactance Transformation System which includes the following table:

Capacitive Reactance	Interval	Inductive Reactance	Interval
1.171875		1.171875	
1.21875	0.046875	1.220703125	0.048828125
1.265625	0.046875	1.26953125	0.048828125
1.3125	0.046875	1.318359375	0.048828125
1.359375	0.046875	1.3671875	0.048828125
1.40625	0.046875	1.416015625	0.048828125
1.453125	0.046875	1.46484375	0.048828125
1.5	0.046875	1.513671875	0.048828125
1.546875	0.046875	1.5625	0.048828125
1.59375	0.046875	1.611328125	0.048828125
1.640625	0.046875	1.66015625	0.048828125
1.6875	0.046875	1.708984375	0.048828125
1.734375	0.046875	1.7578125	0.048828125
			0
1.78125	0.046875	1.7578125	0.048828125
1.828125	0.046875	1.806640625	0.048828125
1.875	0.046875	1.85546875	0.048828125
1.921875	0.046875	1.904296875	0.048828125
1.96875	0.046875	1.953125	0.048828125
2.015625	0.046875	2.001953125	0.048828125
2.0625	0.046875	2.05078125	0.048828125
2.109375	0.046875	2.099609375	0.048828125
2.15625	0.046875	2.1484375	0.048828125
2.203125	0.046875	2.197265625	0.048828125
2.25	0.046875	2.24609375	0.048828125
2.296875	0.046875	2.294921875	0.048828125
2.34375		2.34375	

9. A motor as claimed in claim 6, wherein said processing circuitry calculates resistance within an incoming DC signal, and uses said predetermined periodic transformation system to process said DC signal to reduce resistance therein.

10. A motor as claimed in claim 6, wherein said processing circuitry calculates resistance/impedance in an input AC signal, and uses said predetermined periodic transformation system to process said AC signal to reduce resistance/impedance therein.

11. A motor as claimed in claim 6, wherein said processing circuitry performs phase coherence in accordance with said periodic transformation system.
12. A motor according to claim 6, wherein the power signals come from a power source selected from one or more of the group consisting of electrical, wind, hydrodynamic, gas-powered, nuclear, and mechanical.
13. In a generator for producing electrical energy from another form of energy, the improvement comprising:
- a. a power source selected from one or more of the group consisting of wind, hydrodynamic, fossil fuel, nuclear, geothermal, and mechanical, and producing an electrical output; and
 - b. the system according to claim 1, receiving either DC or AC power from said power source and compensating for phase differences in current and voltage signals therein.
14. A generator as claimed in claim 13, wherein the periodic transformation system comprises a TruScale Reactance Transformation System which includes the following table:

Capacitive Reactance	Interval	Inductive Reactance	Interval
1.171875		1.171875	
1.21875	0.046875	1.220703125	0.048828125
1.265625	0.046875	1.26953125	0.048828125
1.3125	0.046875	1.318359375	0.048828125
1.359375	0.046875	1.3671875	0.048828125
1.40625	0.046875	1.416015625	0.048828125
1.453125	0.046875	1.46484375	0.048828125
1.5	0.046875	1.513671875	0.048828125
1.546875	0.046875	1.5625	0.048828125
1.59375	0.046875	1.611328125	0.048828125
1.640625	0.046875	1.66015625	0.048828125
1.6875	0.046875	1.708984375	0.048828125

Capacitive Reactance	Interval	Inductive Reactance	Interval
1.734375	0.046875	1.7578125	0.048828125
			0
1.78125	0.046875	1.7578125	0.048828125
1.828125	0.046875	1.806640625	0.048828125
1.875	0.046875	1.85546875	0.048828125
1.921875	0.046875	1.904296875	0.048828125
1.96875	0.046875	1.953125	0.048828125
2.015625	0.046875	2.001953125	0.048828125
2.0625	0.046875	2.05078125	0.048828125
2.109375	0.046875	2.099609375	0.048828125
2.15625	0.046875	2.1484375	0.048828125
2.203125	0.046875	2.197265625	0.048828125
2.25	0.046875	2.24609375	0.048828125
2.296875	0.046875	2.294921875	0.048828125
2.34375		2.34375	

15. A generator as claimed in claim 13, wherein said processing circuitry calculates resistance within an incoming DC signal, and uses said predetermined periodic transformation system to process said DC signal to reduce resistance therein.

16. A generator as claimed in claim 13, wherein said processing circuitry calculates resistance/impedance in an input AC signal, and uses said predetermined periodic transformation system to process said AC signal to reduce resistance/impedance therein.

17. A generator as claimed in claim 13, wherein said processing circuitry performs phase coherence in accordance with said periodic transformation system.

18. In a motor for converting electrical energy into another form of energy, the improvement comprising

- a. the system according to claim 1, receiving either DC or AC power from a power source and compensating for phase differences in current and voltage signals therein;

- b. wherein the system of claim 1 receives information relating to a resonant state of said motor and provides an output so as to make said resonant state persistent in said motor.
19. A motor according to claim 18, wherein said resonance is series resonance.
 20. A motor according to claim 19, wherein said motor is a DC motor.
 21. A motor according to claim 19, wherein said motor is an AC motor.
 22. A motor according to claim 18, wherein said resonance is parallel resonance.
 23. A motor according to claim 22, wherein said motor is a DC motor.
 24. A motor according to claim 22, wherein said motor is an AC motor.
 25. A motor as claimed in claim 24, wherein said AC motor is a three-phase AC motor.
 26. A motor as claimed in claim 18, wherein the periodic transformation system comprises a TruScale Reactance Transformation System which includes the following table:

Capacitive Reactance	Interval	Inductive Reactance	Interval
1.171875		1.171875	
1.21875	0.046875	1.220703125	0.048828125
1.265625	0.046875	1.26953125	0.048828125
1.3125	0.046875	1.318359375	0.048828125
1.359375	0.046875	1.3671875	0.048828125
1.40625	0.046875	1.416015625	0.048828125
1.453125	0.046875	1.46484375	0.048828125
1.5	0.046875	1.513671875	0.048828125
1.546875	0.046875	1.5625	0.048828125
1.59375	0.046875	1.611328125	0.048828125
1.640625	0.046875	1.66015625	0.048828125
1.6875	0.046875	1.708984375	0.048828125
1.734375	0.046875	1.7578125	0.048828125

Capacitive Reactance	Interval	Inductive Reactance	Interval
			0
1.78125	0.046875	1.7578125	0.048828125
1.828125	0.046875	1.806640625	0.048828125
1.875	0.046875	1.85546875	0.048828125
1.921875	0.046875	1.904296875	0.048828125
1.96875	0.046875	1.953125	0.048828125
2.015625	0.046875	2.001953125	0.048828125
2.0625	0.046875	2.05078125	0.048828125
2.109375	0.046875	2.099609375	0.048828125
2.15625	0.046875	2.1484375	0.048828125
2.203125	0.046875	2.197265625	0.048828125
2.25	0.046875	2.24609375	0.048828125
2.296875	0.046875	2.294921875	0.048828125
2.34375		2.34375	

27. A motor as claimed in claim 18, wherein said processing circuitry calculates resistance within an incoming DC signal, and uses said predetermined periodic transformation system to process said DC signal to reduce resistance therein.

28. A motor as claimed in claim 18, wherein said processing circuitry calculates resistance/impedance in an input AC signal, and uses said predetermined periodic transformation system to process said AC signal to reduce resistance/impedance therein.

29. A motor as claimed in claim 18, wherein said processing circuitry performs phase coherence in accordance with said periodic transformation system.

30. A motor according to claim 18, wherein the power signals come from a power source selected from one or more of the group consisting of electrical, wind, hydrodynamic, gas-powered, nuclear, and mechanical.

31. In a generator for producing electrical energy from another form of energy, the improvement comprising:

- a. the system according to claim 1, receiving either DC or AC power from a power source selected from one or more of the group consisting of wind, hydrodynamic, fossil fuel, nuclear, geothermal, and mechanical, and compensating for phase differences in current and voltage signals therein;
- b. wherein the system of claim 1 receives information relating to a resonant state of said generator and provides an output so as to make said resonant state persistent in said generator.

32. A generator as claimed in claim 31, wherein said resonant state is a series resonant state.

33. A generator as claimed in claim 31, wherein said resonant state is a parallel resonant state.

34. A generator as claimed in claim 31, wherein the periodic transformation system comprises a TruScale Reactance Transformation System which includes the following table:

Capacitive Reactance	Interval	Inductive Reactance	Interval
1.171875		1.171875	
1.21875	0.046875	1.220703125	0.048828125
1.265625	0.046875	1.26953125	0.048828125
1.3125	0.046875	1.318359375	0.048828125
1.359375	0.046875	1.3671875	0.048828125
1.40625	0.046875	1.416015625	0.048828125
1.453125	0.046875	1.46484375	0.048828125
1.5	0.046875	1.513671875	0.048828125
1.546875	0.046875	1.5625	0.048828125
1.59375	0.046875	1.611328125	0.048828125
1.640625	0.046875	1.66015625	0.048828125
1.6875	0.046875	1.708984375	0.048828125
1.734375	0.046875	1.7578125	0.048828125
			0
1.78125	0.046875	1.7578125	0.048828125
1.828125	0.046875	1.806640625	0.048828125

Capacitive Reactance	Interval	Inductive Reactance	Interval
1.875	0.046875	1.85546875	0.048828125
1.921875	0.046875	1.904296875	0.048828125
1.96875	0.046875	1.953125	0.048828125
2.015625	0.046875	2.001953125	0.048828125
2.0625	0.046875	2.05078125	0.048828125
2.109375	0.046875	2.099609375	0.048828125
2.15625	0.046875	2.1484375	0.048828125
2.203125	0.046875	2.197265625	0.048828125
2.25	0.046875	2.24609375	0.048828125
2.296875	0.046875	2.294921875	0.048828125
2.34375		2.34375	

35. A generator as claimed in claim 31, wherein said processing circuitry calculates resistance within an incoming DC signal, and uses said predetermined periodic transformation system to process said DC signal to reduce resistance therein.

36. A generator as claimed in claim 31, wherein said processing circuitry calculates resistance/impedance in an input AC signal, and uses said predetermined periodic transformation system to process said AC signal to reduce resistance/impedance therein.

37. A generator as claimed in claim 31, wherein said processing circuitry performs phase coherence in accordance with said periodic transformation system.

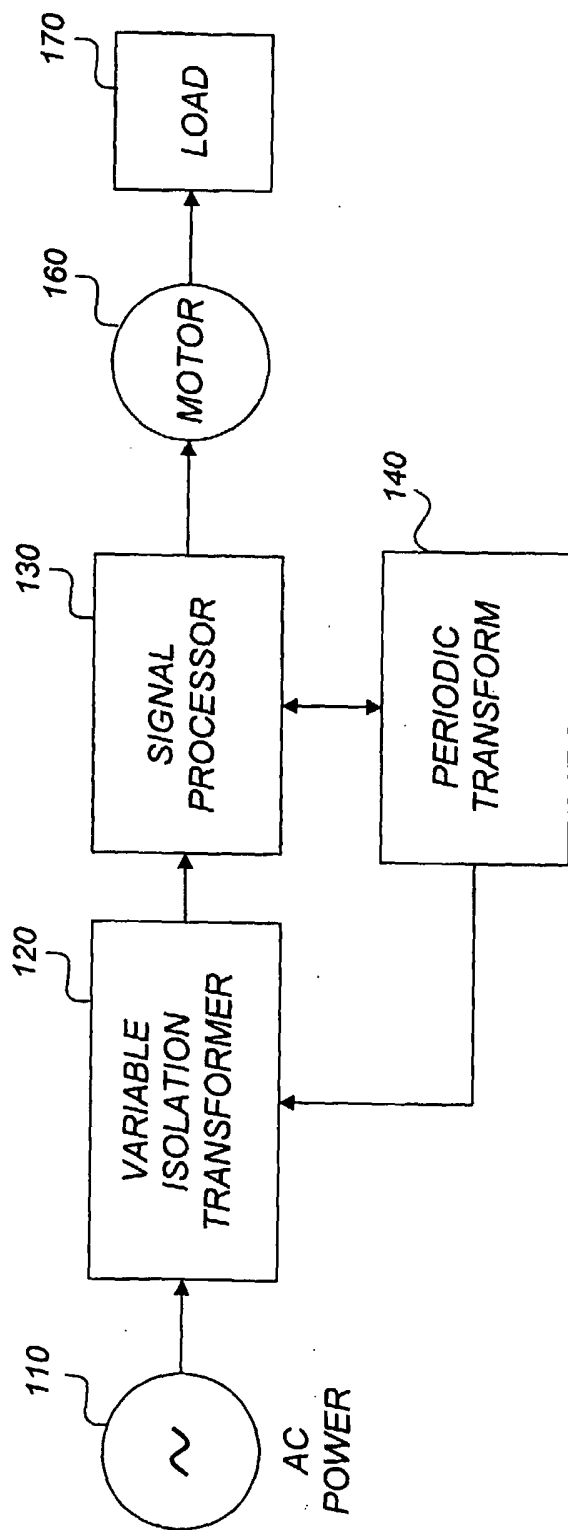

FIG. 1A

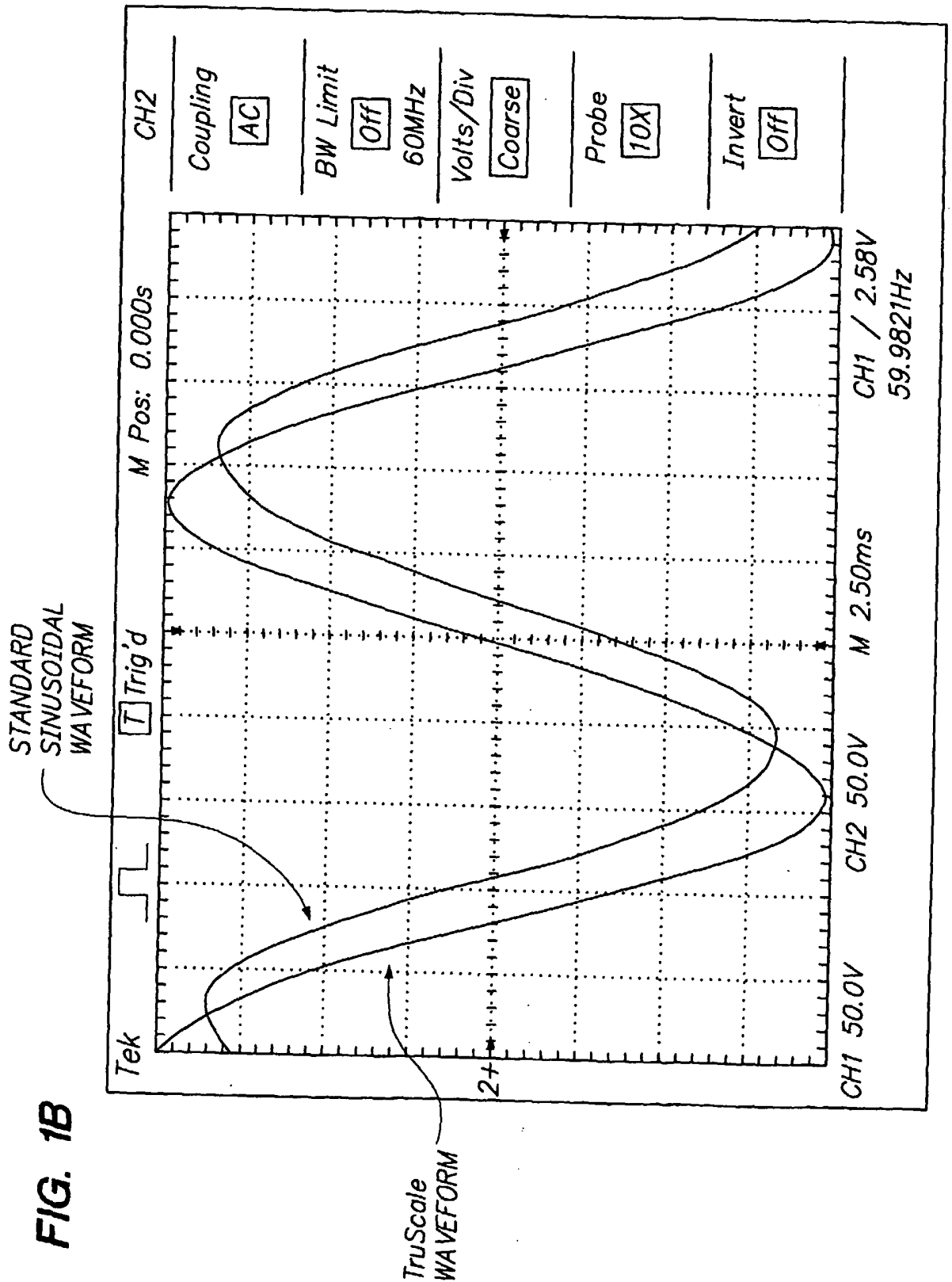

FIG. 1B

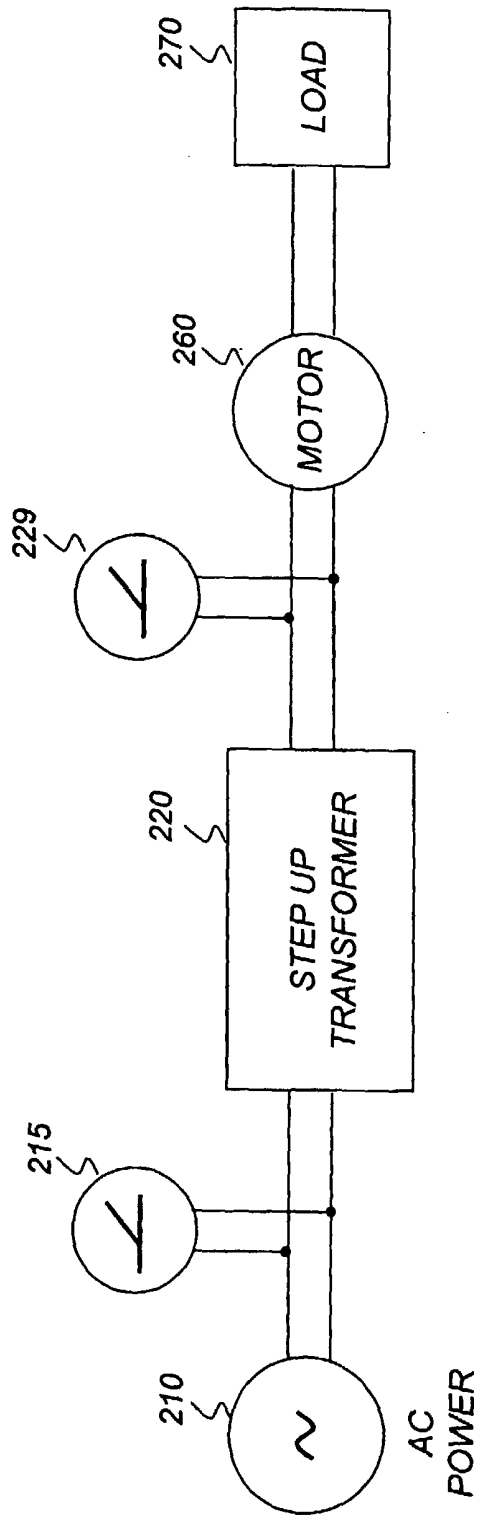

FIG. 2A

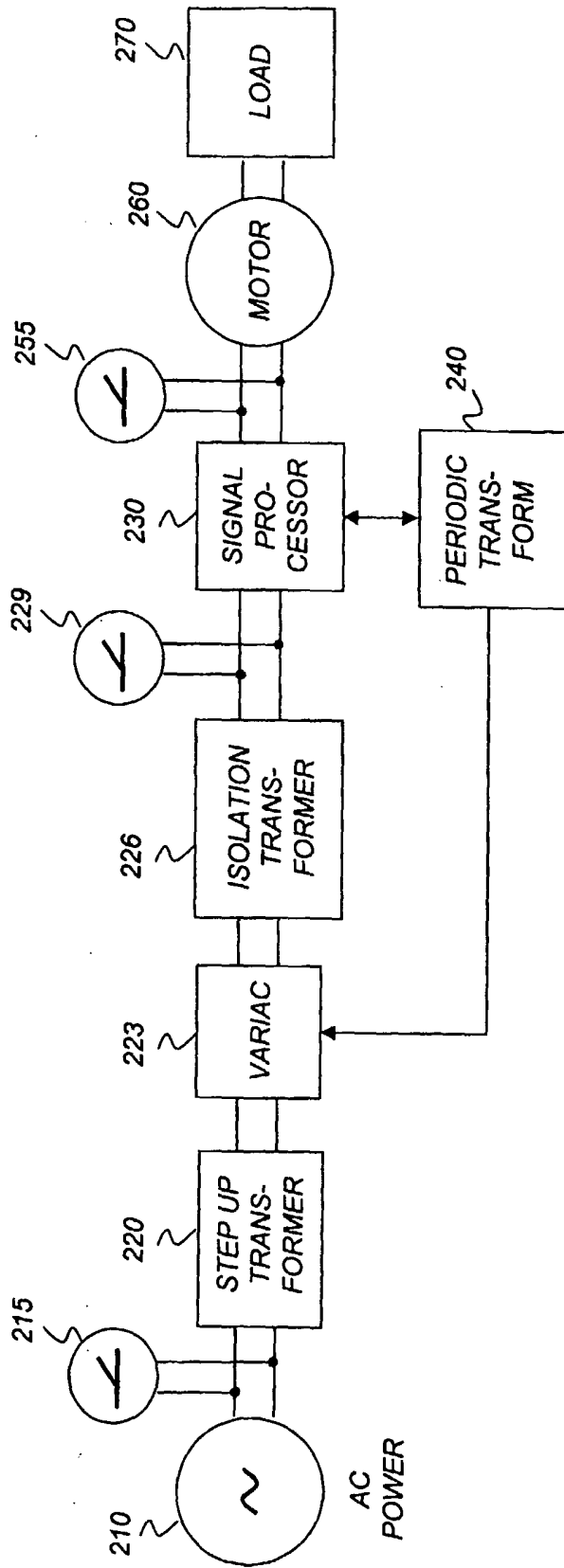

FIG. 2B

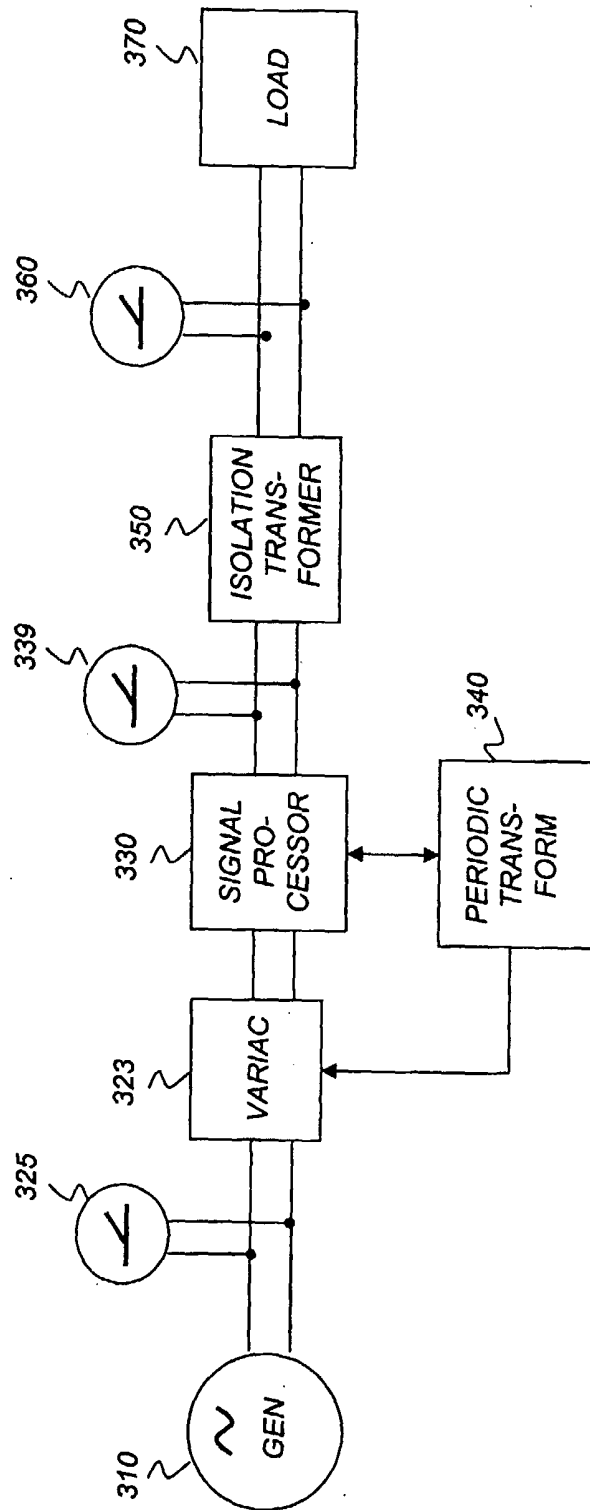

FIG. 3

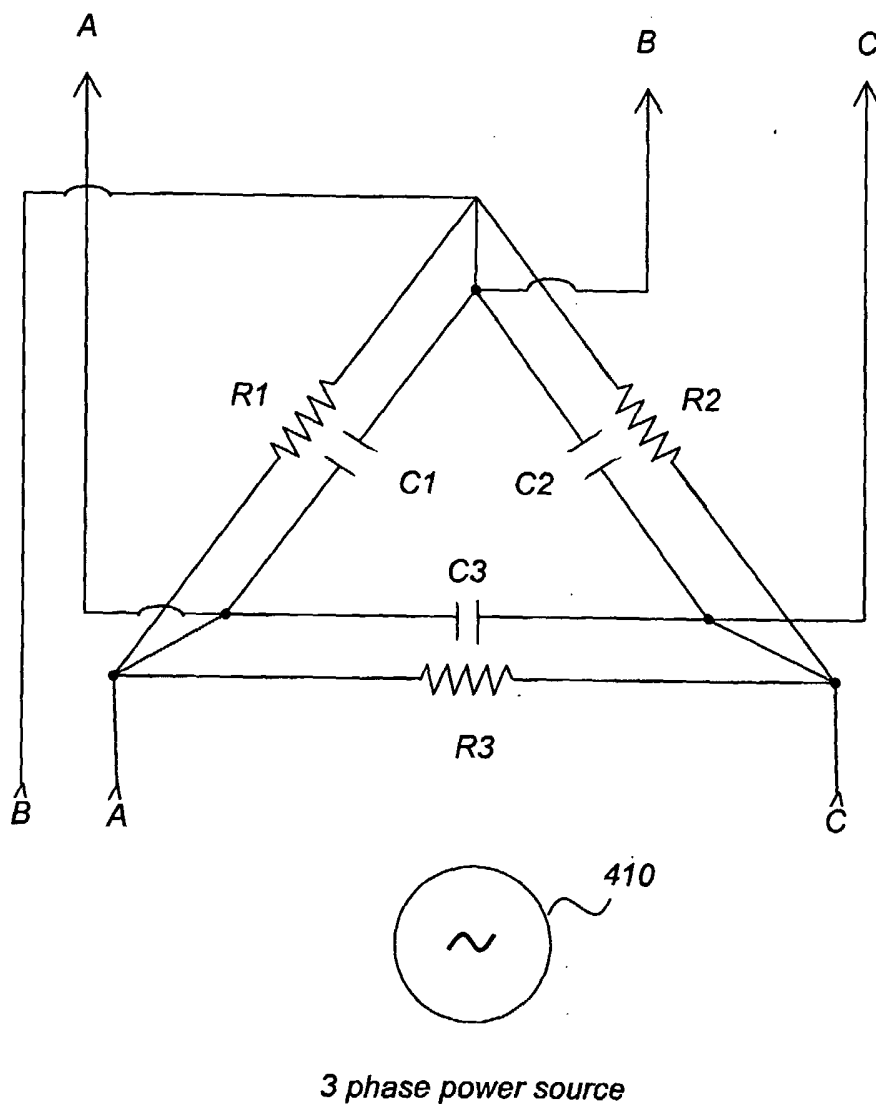

FIG. 4

INTERNATIONAL SEARCH REPORT

International application No
PCT/US2005/036131

A. CLASSIFICATION OF SUBJECT MATTER
H02M1/00 H02K53/00

According to International Patent Classification (IPC) or to both national classification and IPC

B. FIELDS SEARCHED

Minimum documentation searched (classification system followed by classification symbols)
H02M H02K

Documentation searched other than minimum documentation to the extent that such documents are included in the fields searched

Electronic data base consulted during the international search (name of data base and, where practical, search terms used)

EPO-Internal

C. DOCUMENTS CONSIDERED TO BE RELEVANT

Category*	Citation of document, with indication, where appropriate, of the relevant passages	Relevant to claim No.
A	US 6 297 980 B1 (SMEDLEY KEYUE M ET AL) 2 October 2001 (2001-10-02) abstract column 1, line 25 - column 4, line 16; figures 1-10	1-37
A	----- ANGRIST S W: "PERPETUAL MOTION MACHINES" SCIENTIFIC AMERICAN, SCIENTIFIC AMERICAN INC., NEW YORK, NY, US, vol. 218, no. 1, January 1968 (1968-01), pages 114-122, XP002036811 ISSN: 0036-8733 page 121, column 3 - page 122, column 3 ----- -/--	1-37

Further documents are listed in the continuation of Box C.

See patent family annex.

* Special categories of cited documents :

A document defining the general state of the art which is not considered to be of particular relevance

E earlier document but published on or after the international filing date

L document which may throw doubts on priority claim(s) or which is cited to establish the publication date of another citation or other special reason (as specified)

O document referring to an oral disclosure, use, exhibition or other means

P document published prior to the international filing date but later than the priority date claimed

T later document published after the international filing date or priority date and not in conflict with the application but cited to understand the principle or theory underlying the invention

X document of particular relevance; the claimed invention cannot be considered novel or cannot be considered to involve an inventive step when the document is taken alone

Y document of particular relevance; the claimed invention cannot be considered to involve an inventive step when the document is combined with one or more other such documents, such combination being obvious to a person skilled in the art.

& document member of the same patent family

Date of the actual completion of the international search

9 February 2006

Date of mailing of the international search report

23/02/2006

Name and mailing address of the ISA/

European Patent Office, P.B. 5818 Patentlaan 2
NL - 2280 HV Rijswijk
Tel. (+31-70) 340-2040, Tx. 31 651 epo nl,
Fax: (+31-70) 340-3016

Authorized officer

Zeng, W

INTERNATIONAL SEARCH REPORT

International application No
PCT/US2005/036131

C(Continuation). DOCUMENTS CONSIDERED TO BE RELEVANT		
Category*	Citation of document, with indication, where appropriate, of the relevant passages	Relevant to claim No.
A	<p>US 6 003 000 A (OZZIMO ET AL) 14 December 1999 (1999-12-14)</p> <p>abstract; figures 3A,3B; table 1 -----</p>	<p>1,2,6,8, 13,14, 18,26, 31,34</p>
A	<p>US 6 366 483 B1 (MA DAMING ET AL) 2 April 2002 (2002-04-02) abstract; figures 1,2,11 -----</p>	<p>1,6,13, 18,31</p>
A	<p>US 4 914 559 A (DEISCH ET AL) 3 April 1990 (1990-04-03) abstract; figures 1-10 -----</p>	<p>1,6,13, 18,31</p>

INTERNATIONAL SEARCH REPORT

International application No.
PCT/US2005/036131

Box II Observations where certain claims were found unsearchable (Continuation of item 2 of first sheet)

This International Search Report has not been established in respect of certain claims under Article 17(2)(a) for the following reasons:

1. Claims Nos.: 1-2, 6, 8, 13-14, 18, 26, 31, 34 (all partially)
because they relate to subject matter not required to be searched by this Authority, namely:
see FURTHER INFORMATION sheet PCT/ISA/210
2. Claims Nos.: 1-2, 6, 8, 13-14, 18, 26, 31, 34 (all partially)
because they relate to parts of the International Application that do not comply with the prescribed requirements to such an extent that no meaningful International Search can be carried out, specifically:
see FURTHER INFORMATION sheet PCT/ISA/210
3. Claims Nos.:
because they are dependent claims and are not drafted in accordance with the second and third sentences of Rule 6.4(a).

Box III Observations where unity of invention is lacking (Continuation of item 3 of first sheet)

This International Searching Authority found multiple inventions in this international application, as follows:

1. As all required additional search fees were timely paid by the applicant, this International Search Report covers all searchable claims.
2. As all searchable claims could be searched without effort justifying an additional fee, this Authority did not invite payment of any additional fee.
3. As only some of the required additional search fees were timely paid by the applicant, this International Search Report covers only those claims for which fees were paid, specifically claims Nos.:
4. No required additional search fees were timely paid by the applicant. Consequently, this International Search Report is restricted to the invention first mentioned in the claims; it is covered by claims Nos.:

Remark on Protest

- The additional search fees were accompanied by the applicant's protest.
- No protest accompanied the payment of additional search fees.

INTERNATIONAL SEARCH REPORT

International Application No. PCT/US2005 /036131

FURTHER INFORMATION CONTINUED FROM PCT/ISA/ 210

Continuation of Box II.1

Claims Nos.: 1-2, 6,8,13-14, 18, 26, 31, 34 (all partially)

The claims are not clear or sufficiently supported by the description as required by Article 6 PCT, furthermore the application has not sufficiently disclose the invention so that a skilled person can carry out the invention as required by Article 5 PCT, in addition the application contains subject-matter which contradicts fundamental laws of physics (Table 3-6 and paragraphs 0030-0037). A complete search covering the unclear claims of the present application is thus not possible.

Continuation of Box II.2

Claims Nos.: 1-2, 6,8,13-14, 18, 26, 31, 34 (all partially)

The claims are not clear or sufficiently supported by the description as required by Article 6 PCT, furthermore the application has not sufficiently disclose the invention so that a skilled person can carry out the invention as required by Article 5 PCT, in addition the application contains subject-matter which contradicts fundamental laws of physics (Table 3-6 and paragraphs 0030-0037). A complete search covering the unclear claims of the present application is thus not possible.

The applicant's attention is drawn to the fact that claims relating to inventions in respect of which no international search report has been established need not be the subject of an international preliminary examination (Rule 66.1(e) PCT). The applicant is advised that the EPO policy when acting as an International Preliminary Examining Authority is normally not to carry out a preliminary examination on matter which has not been searched. This is the case irrespective of whether or not the claims are amended following receipt of the search report or during any Chapter II procedure. If the application proceeds into the regional phase before the EPO, the applicant is reminded that a search may be carried out during examination before the EPO (see EPO Guideline C-VI, 8.5), should the problems which led to the Article 17(2) declaration be overcome.

INTERNATIONAL SEARCH REPORT

Information on patent family members

International application No

PCT/US2005/036131

Patent document cited in search report	Publication date	Patent family member(s)	Publication date
US 6297980	B1	02-10-2001	US 2002149953 A1 17-10-2002
US 6003000	A	14-12-1999	NONE
US 6366483	B1	02-04-2002	NONE
US 4914559	A	03-04-1990	NONE