



12

EUROPEAN PATENT APPLICATION

21 Application number : **92302090.3**

51 Int. Cl.⁵ : **B65D 71/06**

22 Date of filing : **11.03.92**

30 Priority : **12.03.91 FI 911222**

43 Date of publication of application :
16.09.92 Bulletin 92/38

84 Designated Contracting States :
**AT BE CH DE DK ES FR GB GR IT LI LU MC NL
PT SE**

71 Applicant : **JAAKKO PÖYRY OY**
Martinkatu 3
SF-01621 Vantaa (FI)

72 Inventor : **Ebeling, Jaakko**
Helsingintie 46
SF-02700 Kauniainen (FI)
Inventor : **Pesonen, Jarmo**
Kokinkyläntie 26 A
SF-02180 Espoo (FI)

74 Representative : **Barlow, Roy James**
J.A. KEMP & CO. 14, South Square, Gray's Inn
London WC1R 5LX (GB)

54 **Transport package.**

57 The present invention relates to a transport package (1), comprising a transport pallet (2), goods (3) on said transport pallet, and a tight wrapping (4) protecting and binding together the goods. According to the invention, also the transport pallet (2) has been wrapped within the wrapping (4), advantageously together with the goods (3) thereon, into a plastic film web to form one united transport package.

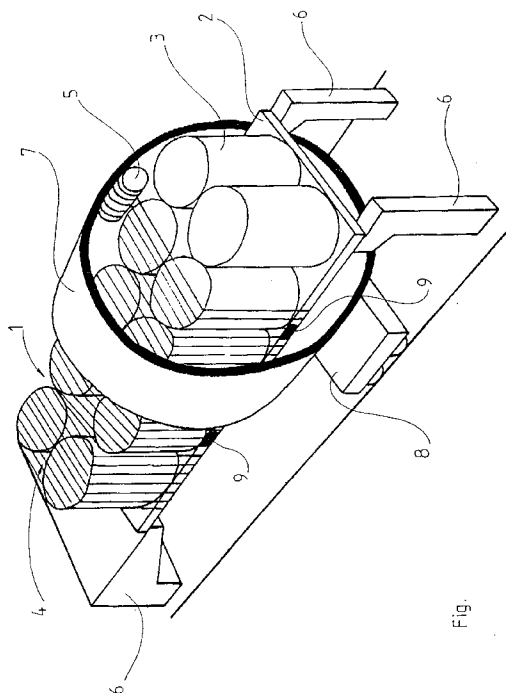

The present invention relates to a transport package, comprising a transport pallet, goods on said transport pallet, such as paper rolls and/or sheets of paper, and a tight wrapping protecting and binding together said goods.

Packing, protecting and securing a load so that the goods to be transported arrive intact to the destination, particularly in a transport chain containing several different forms of transport, such as car-train-boat, have proved to be particularly problematic and cost involving, and no satisfactory solution has been found thereto.

Binding a load on a truck body, into a railway wagon or on various transport pallets used in marine transport, such as ferry wagons and containers, as well as various modifications thereof, is difficult and technically complex. In sea transport this has proved particularly problematic, and roll on-roll off crafts have even capsized due to shifting of load when the securing of the load has failed when the sea is rough, and even if no such dramatic accidents would take place, great damages are, nevertheless, continuously caused to the loads during sea transports.

It has not been possible to mechanize the securing a load to its transport pallet by means of the state-of-art procedures. Securing a load is technically difficult and requires plenty of human labour, which is expensive. As to the roll on - roll off crafts, it is difficult to obtain a satisfactory end result because of the high cargoes of these crafts which are indispensable because of their transport economy, said cargoes being very high, particularly in relation to the width of the transport pallet and therefore very difficult to be secured to their transport pallet satisfactorily.

Goods to be transported on small transport bases, such as pallets, have in some cases been wrapped in plastic films, whereby the wrapping has been carried out substantially horizontally up to the margins of the transport pallet. The aim is primarily to shelter the goods on the transport pallet against dirt and moisture. If one wants to prevent further the package against displacement caused by high acceleration forces generated in the course of the transport, the package is after the wrapping tied generally with a shroud to its transport pallet.

A repeated treatment of individual packages often causes great damage both to the package and the packed goods. For instance, products from wood industries, such as paper rolls and sheets, are typically treated in the present day transport chain 6 to 10 times between the manufacturing installation and the site of the end user. Therefore, the packing of an individual product, such as paper roll, has to be made to last a several treatments and various potential dangers during the transport, such as moisture, pressing, blows, and so on. The package of an individual product is therefore expensive and in addition, the treatment of the packaging material by the receiver is

expensive and harmful to the environment. Weather-proof packages are often cardboard-plastic laminates, which cannot be recycled or destroyed by burning. The only solution is to take them to the dump pit.

The objective of the present invention is to provide a transport package of the type described in the introduction, in which the above shortcomings have been eliminated. The main characteristic features of the invention become obvious in the accompanying claims.

Instead of packing individual goods separately for sheltering them against damaging during transport, and in addition to the fact that the goods on the transport pallet are separately secured to their transport pallet to preventing cargo displacement, also the transport pallet, as referred to in the transport pallet of the invention, is wrapped in said wrapping together with the goods thereon to form a united transport package. Such transport package is not only well protected but also easy to secure during the transport by anchoring the transport pallet in any manner known per se in the art, whereby also the goods on the transport pallet remain in place.

In the preferred embodiment of the invention the wrapping around the transport pallet and the goods thereupon consists of a stretched plastic film web wrapped transversally around the transport pallet and the goods thereon substantially in vertical direction, said web being guidable for reuse as raw material for the plastic industry.

The transport package of the invention is conveniently provided using circumferential wrapping machines known in the art, used for instance in wrapping paper rolls into a plastic film web.

The transport package according to the present invention is particularly appropriate for megacargo units in cargo boats, described in the Finnish publication print No. 83067, in which the cargo volume has been divided into freely selectable partial volumes defined by the cargo height. In the megacargo units as described by said publication print the cargo to be gathered on the intermediate platforms need not be as high as otherwise for ensuring the transport economy. Since the size of the cargo on such intermediate platforms is smaller than usual, the cargo can be tied in place with plastic film webs, i.e. using the transport packages of the invention.

The invention is described more fully below, reference being made to the accompanying drawing presenting a perspective image of a wrapping machine suited for wrapping a transport package according to the invention, and of a transport package according to the invention to be wrapped therein.

In the drawing the transport package to be wrapped is in general indicated by reference numeral 1. The transport pallet forming part of the transport package 1 is indicated by reference numeral 2 and the

goods thereon, such as paper rolls in the present instance, by reference numeral 3. The tight wrapping protecting the goods and tying them together is indicated by reference numeral 4, and, as shown in the drawing, also the transport pallet 2 has been wrapped within said wrapping 4 together with the goods thereon to form one united transport package 1.

The wrapping machine consists of platforms 6 and a wagon 8 moving reciprocatingly therebetween, said wagon being provided with a frame 7 thereon, along the inner side of which the storage space 5 of the plastic film web is moving.

The transport pallet 2 and the goods 3 thereon are resting supported by the ends of the transport pallet 2 on the platforms 6 of the wrapping machine, inside the frame 7, whereby the transport pallet 2 and the goods 3 thereon are wrapped in plastic film web while the storage roller 5 is rotating along the inner surface of the frame 7 around the transport package 1 simultaneously as the wagon 8 and the frame 7 thereon move along the transport package 1 from one end to the other. The plastic film web is stretched while being wrapped, whereby a very tight wrapping 4 is formed around the transport package 1. The side margins of the transport pallet 2 are provided with recesses 9, so that the transport package 1 can be anchored in place during the transport.

By means of the transport package of the invention, for instance the following advantages are gained.

- The transport pallet and the goods on said pallet have been wrapped with a plastic film to form one entity, whereby an elastic and dynamic securing is achieved, which prevents the cargo from moving on the transport pallet,
- the binding force of the package (between the goods and the transport pallet) can be regulated to meet the requirements set by the circumstances by using plastic films of different thicknesses for the wrapping, or by increasing or decreasing the number of films and the prestretching of the film,
- securing of the cargo to the transport pallet lasting throughout the entire transport chain and at the same time, protection of the goods to be transported are obtained using said form of packaging, whereby packing an individual product can be reduced or omitted entirely,
- securing the products to the transport pallet can be carried out mechanically, i.e. in an entirely automated fashion,
- the package can be transported as one unit in trucks, on the railroad and on board so that also in a transport chain containing several different forms of transport a package is provided which travels in unloaded form from the supplier to the customer, and the individual products are not touched in the course of the entire transport chain.

Claims

1. A transport package (1), comprising a transport pallet (2), goods (3) on said transport pallet, such as paper rolls, and a tight wrapping (4) protecting the goods and binding them together, characterized in that also the transport pallet (2) has been wrapped into said wrapping (4) together with the goods (3) thereon to form a united transport package.
2. Transport package according to claim 1, characterized in that the wrapping (4) consists of a stretched plastic film web wrapped transversally around the transport pallet (2) and the goods (3) thereon, substantially in vertical direction.

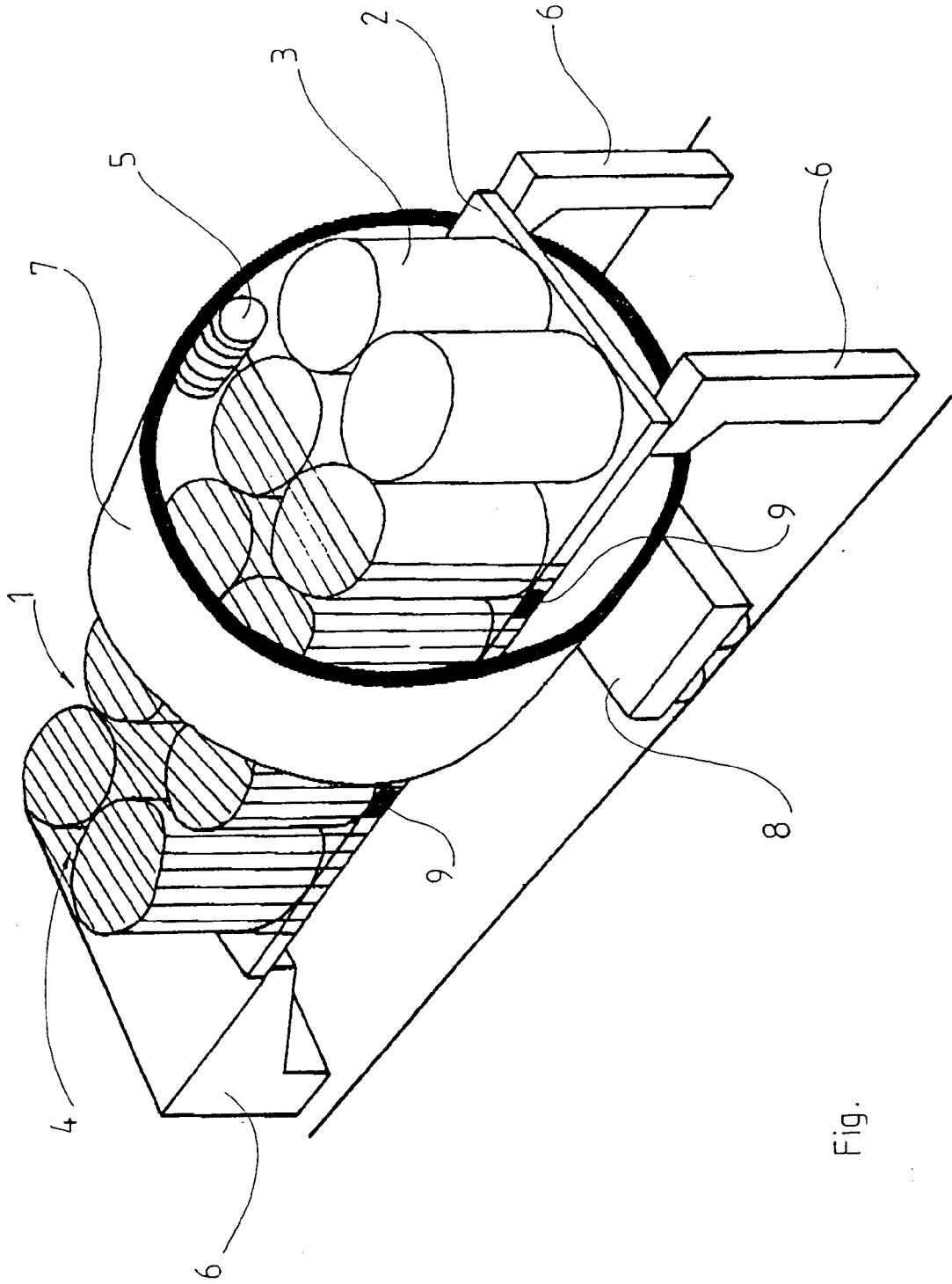

Fig.