



(19) **United States**
(12) **Patent Application Publication**
Rogers et al.

(10) **Pub. No.: US 2013/0033742 A1**
(43) **Pub. Date: Feb. 7, 2013**

(54) **VERY HIGH POWER PULSED FIBER LASER**

(60) Provisional application No. 60/526,613, filed on Dec. 4, 2003.

(75) Inventors: **Philip Rogers**, Hume, VA (US);
Priyavadan Mamidipudi, Bristow, VA (US); **Rupak Changkakoti**, Haymarket, VA (US); **Peter Gatchell**, Nokesville, VA (US)

Publication Classification

(51) **Int. Cl.**
H01S 3/067 (2006.01)
(52) **U.S. Cl.** **359/341.3; 372/6; 359/341.1**

(73) Assignee: **Optical Data Air Systems, LLC**,
Manassas, VA (US)

(57) **ABSTRACT**

(21) Appl. No.: **13/613,808**

A pulsed fiber laser including fiber preamplifier and power amplifier stages is disclosed. A fiber preamplifier includes first and second preamplifier stages that receive and amplify a seed pulse. A filter isolator placed between the preamplifier stages suppresses noise from the first preamplifier stage. An acoustic optical modulator located in the second preamplifier stage eliminates unwanted wavelengths from the amplified seed pulse received from the first preamplifier stage. The pulsed fiber laser is rugged and lightweight.

(22) Filed: **Sep. 13, 2012**

Related U.S. Application Data

(63) Continuation of application No. 12/815,057, filed on Jun. 14, 2010, now Pat. No. 8,270,441, which is a continuation of application No. 10/581,416, filed on Jun. 2, 2006, now Pat. No. 7,738,514, filed as application No. PCT/US2004/040572 on Dec. 6, 2004.

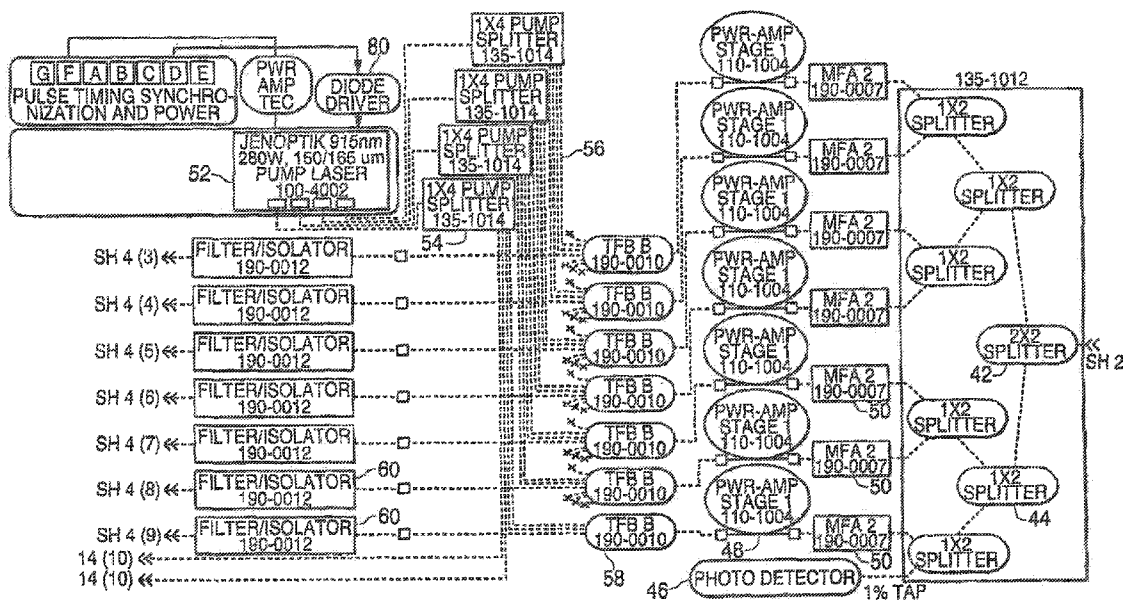

FIG. 1

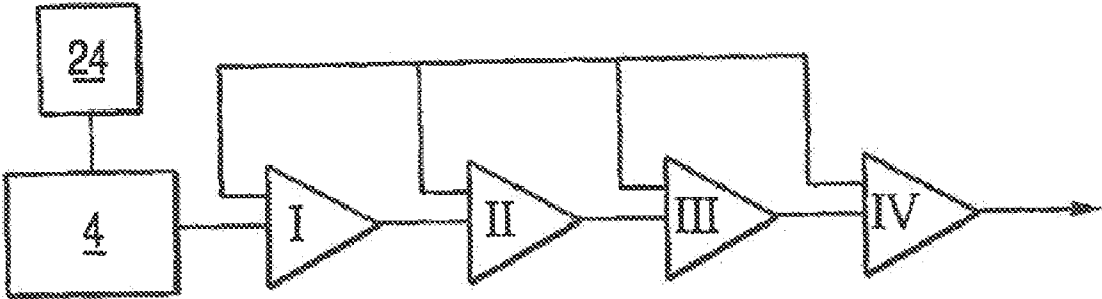

FIG. 3

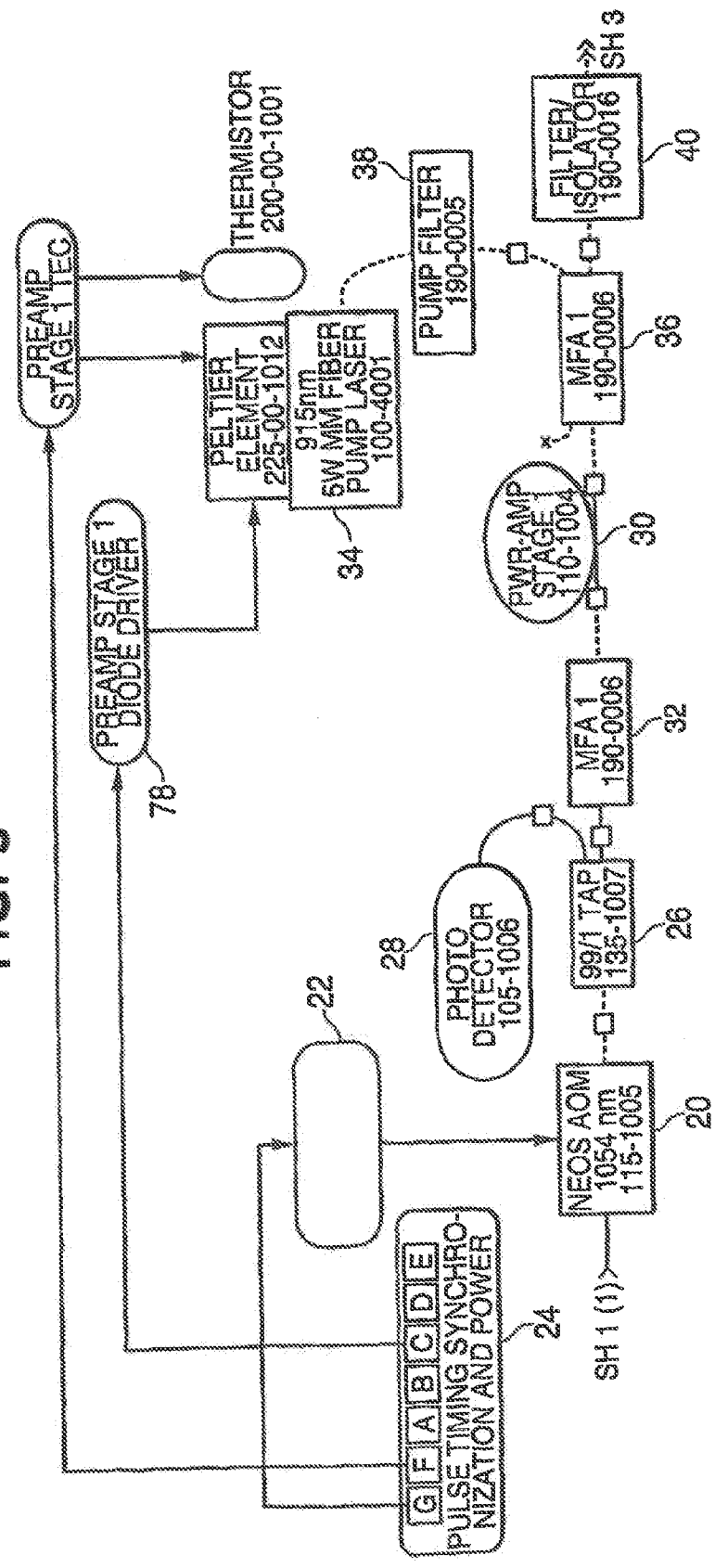

FIG. 4

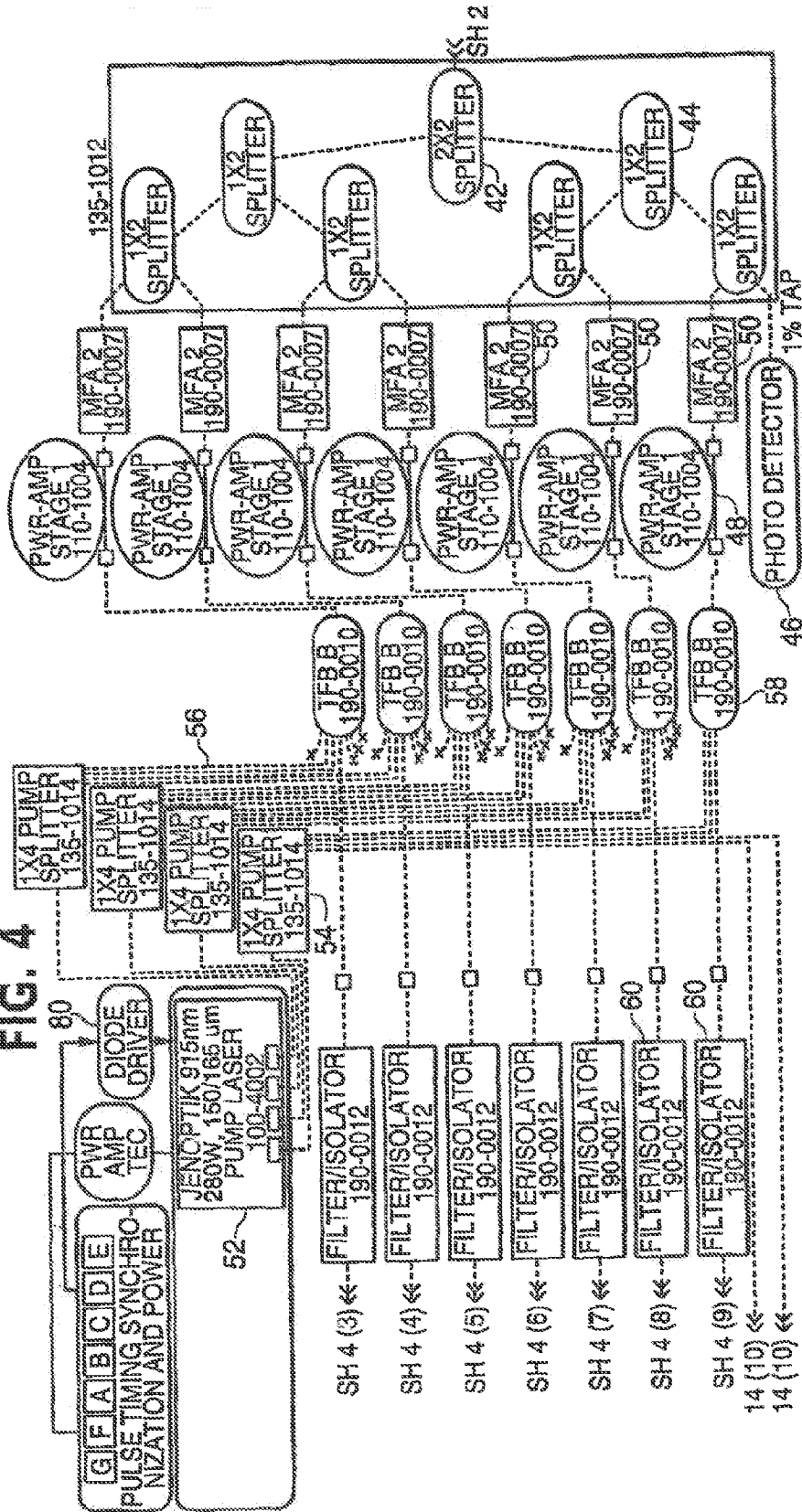
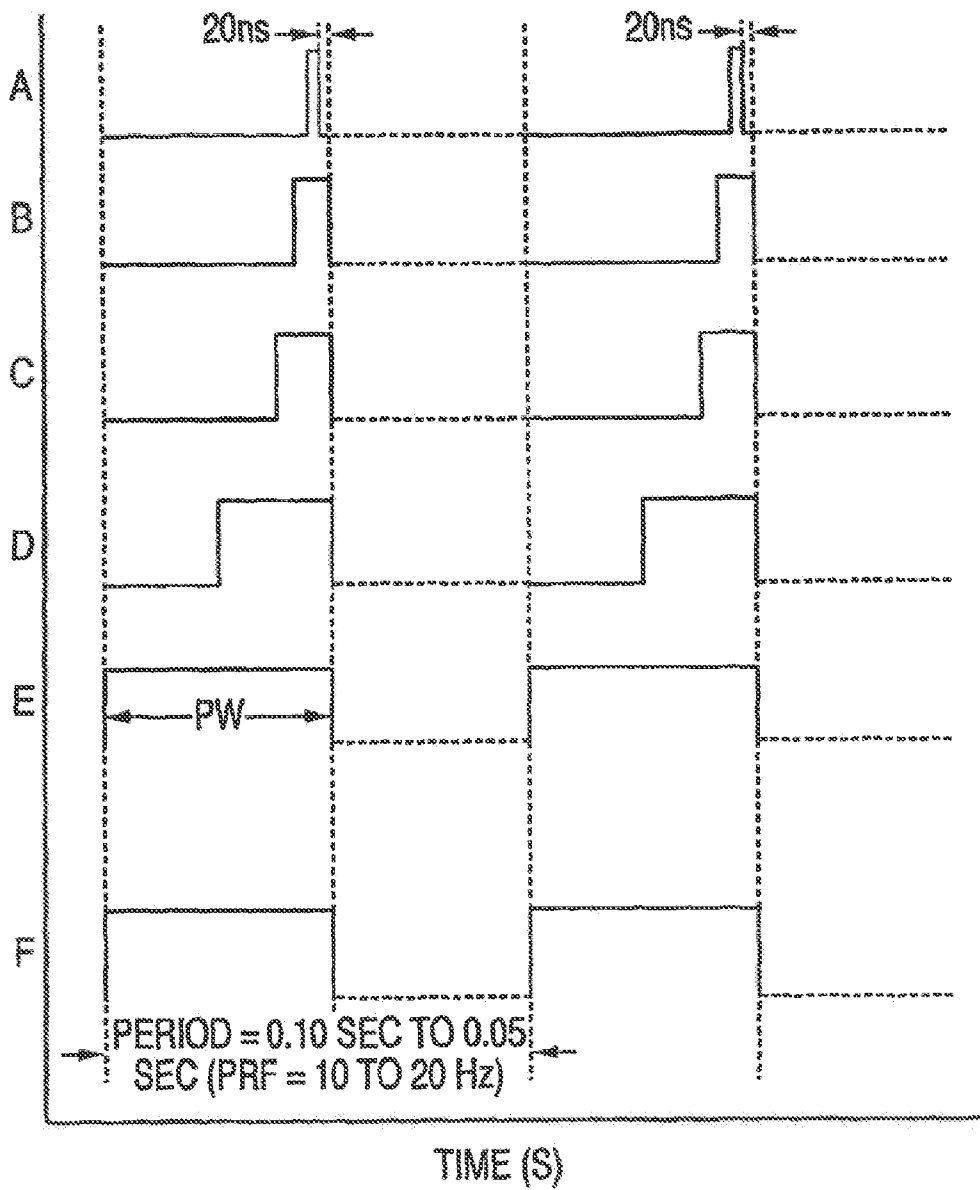

FIG. 6



VERY HIGH POWER PULSED FIBER LASER**CROSS REFERENCE TO RELATED APPLICATIONS**

[0001] This application is a Continuation of U.S. application Ser. No. 12/815,057, filed Jun. 14, 2010 (now U.S. Pat. No. 8,270,441), which is a Continuation of U.S. application Ser. No. 10/581,416, filed Jun. 2, 2006 (now U.S. Pat. No. 7,738,514), which is the National Phase Entry of International Application No. PCT/US2004/040572 filed on Dec. 6, 2004, which claims benefit of U.S. Provisional Application No. 60/526,613, filed Dec. 4, 2003. All of these applications are incorporated by reference in their entireties.

TECHNICAL FIELD

[0002] This invention relates to the art of high-power fiber lasers. In particular, the invention relates to the art of high-power, fully integrated fiber laser systems.

BACKGROUND ART

[0003] Optical fiber amplifiers that receive coherent light of relatively low power from a seed laser and amplify that light with fiber laser amplifiers are known. When the systems are to be used for such applications as target marking, target ranging, imaging, and tracking, and LIDAR, among others, a primary objective has been to obtain a high-power, single mode output, or output with relatively low multimode content. This is particular difficult because of the necessity of controlling amplified spontaneous emission (ASE), controlling the excitation of unwanted modes, and reducing the effects of non-linearity. One technique that has been proposed includes that of cascaded, pulse-pumped amplifiers where pumping is synchronized with the pulse to be amplified. Such a system is shown in U.S. Pat. No. 5,933,271. This is however limited to relatively low pulse peak powers when compared to conventional solid state lasers that are capable of peak powers in the hundreds of kilowatts to megawatts.

SUMMARY

[0004] Increase in the power of a near diffraction-limited CW beam generated from doped (Yb, Er, Yb:Er, Nd etc.) fiber lasers constitutes an important advancement, because this fiber technology is uniquely efficient and providing fully integrated fiber laser systems. Achieving high pulse energies with pulsed fiber lasers is a much more formidable problem, and the successful solution as described herein leads to a number of practically important applications. Difficulty in scaling pulse energies arises from the limited size of the fiber core and the relatively long pulse propagation length necessary to achieve high gain. Peak powers within fiber-based amplifier systems are further limited by non-linear phenomena within the fiber. Increasing the size of the core appears to be one of the main directions of the technological advancement towards higher energies. This scaling, however, can result in a highly multimode core and, consequently, to significant degradation of the beam quality.

[0005] The present invention relates to the generation of greater than 50-mJ, 10-ns pulses, with a total peak power of 5 MWatts. Another aspect of the invention is that the mode quality of a highly multimode, large-core fiber can be significantly improved by using the mode-filtering effect of a coiled, low-NA core. The invention uses a coiled fiber of about 115 μm diameter and low numerical aperture core, which supports

a large number of transverse modes, to produce low divergence output beam with M^2 between 6 and 8 and preferably 6.5, thus effectively reducing number of modes at the output of the fiber to a small number of modes. The numerical aperture of the fiber is preferably between 0.06 and 0.08 and is more preferably about 0.07. The diameter of the coil is preferably about nine to eleven inches and more preferably about 10 inches. Effective numerical apertures of 0.04 for the beam can be achieved with such fiber amplifiers.

[0006] The preferred arrangement comprises an all-fiber, cascaded four amplifier system seeded with an electric-pulse-driven, single-longitudinal-mode diode laser emitting at 1064 nm. This arrangement allows for a very high power, pulsed, laser source tunable from 1030 nm to 1085 nm. Such seeding enables control of both the shape of the seed pulse and its repetition rate, which is selectable by the electric-pulse generator in the range from a single shot to 1 MHz. (It may not be possible to use pulse pumping at seed pulse frequencies approaching 1 MHz. At the higher frequencies, the pumping is preferably continuous.) Seed pulses as low as 10-30 nJ are amplified in a single-mode, core-pumped Yb-doped fiber pre-amplifier, having standard optical components and pumped with telecom-grade 980-nm single-mode diodes. For pulse repetition rates in the range from 10 Hz to 100 Hz, up to 500 nJ has been obtained in the preamplifier stage. These pulses are then launched into a cladding-pumped 10- μm diameter core Yb-doped fiber amplifier with a 125 1-1 m cladding to produce up to 50 μJ per pulse. Isolation from ASE is achieved by the use of optical isolators, electro-optical time gates, and narrow bandpass filters at 1064 nm to suppress 1039-nm peak ASE emission between the stages. ASE is also limited by the use of pulse pumping that is timed with the pulses to be amplified. Previous systems have relied on the ability to use large average powers of the seed signal to overcome issues of spontaneous emissions with the amplifiers. This, however, has limited the ability to develop fiber laser amplifiers at low pulse repetition frequencies.

[0007] The output from the second preamplifier stage is then divided into a plurality of channels. As many as seven channels have been demonstrated. This preferably is accomplished by directing the output from the preamplifier into a series of splitters. Each of the outputs from the splitters is directed to a mode field adaptor that couples the light pulse to the first stage of a clad pumped fiber laser power amplifier. The first stage of the power amplifier preferably comprises a coiled gain fiber having a 30 μm core and a 250 μm cladding.

[0008] The fiber amplifiers of the first stage of the power amplifier are pulse pumped. The pulsed pumping light is directed into the amplifier cladding by the use of a tapered fiber bundle. Tapered fiber bundles are known, and those used in the preferred embodiment of the invention are manufactured to minimize loss and suppression of unwanted modes. Tapered fiber bundles can be effectively used as a means of stripping off unwanted higher order modes generated within the gain medium.

[0009] The output from each of the first stage power amplifier fibers is directed to a fiber laser amplifier of the second stage of the power amplifier. The fiber laser amplifiers of the second stage of the power amplifier are also pulse pumped by directing the pumping light into a tapered fiber bundle, which couples the pump light into the cladding of the fiber of the second stage of the power amplifier.

[0010] The second power amplifier stage utilizes a clad gain fiber having a 115 μm core diameter and a 350 μm

cladding. The final power amplifier stage is based on a large core, double-clad 3-5 m long Yb-doped fiber with 115 μm diameter, low numerical aperture core as defined above, and 600- μm diameter, 0.46 NA inner pump cladding. The amplifier was end-pumped with 915-nm diode laser.

[0011] Amplified signals generated within the various channels of the system can be re-combined with one another to further enhance the peak power of the amplifier. This is achieved by controlling the signal and pump pulse timings within the various parallel legs of the system. It will be appreciated that the invention provides nanosecond pulse energies in the tens of millijoules range with very large core fibers. Large core dimensions ensure significant extractable pulse energies as well as increased susceptibility to detrimental nonlinear and bulk damage effects. Mode quality can be significantly improved by using coiled, low NA fibers to ensure loss for higher order transversal modes.

[0012] It is an object of this invention to provide a high power fiber laser amplifier.

[0013] It is a further object of this invention to provide a fully integrated high power fiber laser amplifier.

[0014] It is yet another object of this invention to provide a high power fiber laser system having one or more fiber amplifier stages using coiled low numerical aperture clad fiber amplifiers and tapered fiber bundles to provide pump energy to the amplifier cladding.

BRIEF DESCRIPTION OF THE DRAWINGS

[0015] FIG. 1 is a block diagram of the overall design of the preferred embodiment.

[0016] FIGS. 2-5 are schematic diagrams of a four stage integrated laser fiber amplifier in accordance with the invention.

[0017] FIG. 6 is a graph illustrating pulse timing in accordance with the invention.

DETAILED DESCRIPTION OF THE EMBODIMENTS

[0018] In the preferred embodiment, the invention is an all-fiber, integrated laser system that is capable of producing very high peak power. The system is rugged and lightweight, which means that it is particularly useful for use in portable instruments used in severe environments, such as military high vibration and shock applications. One such use is that of laser targeting. Other potential applications include aircraft systems, space based systems, as well as commercial platforms (material processing, welding, laser surgery) where precise control over pulse widths, pulse shapes, pulse repetition frequencies, peak powers, and high electrical to optical conversion efficiencies can provide the user with immense advantages. Typical solid state laser systems lack such abilities of wavelength tenability, pulse control, as well as precision pointing which are possible with a fiber amplifier demonstrating comparable peak powers and mode content. This design for fiber amplifiers is not limited to this wavelength of 1064 nm, and holds true for fiber amplifier systems ranging from the near ultraviolet to the infrared.

[0019] FIG. 1 is a block diagram showing the overall design of an all-fiber, integrated laser system in accordance with the invention. The system includes a pulsed laser 4 that providing a seed signal to a cascaded set of fiber laser amplifiers, illustrated at I, II, III, and IV. The laser amplifiers are preferably pulse pumped, and the timing of the pumping is controlled by

control circuit 24. The individual amplifier stages will be described in more detail in connection with FIGS. 2 through 5.

[0020] FIG. 2 is a schematic diagram of the first stage of a preamplifier in accordance with a preferred embodiment of the invention. The embodiment shown in FIG. 2 comprises a first stage preamplifier that is generally of MOPA configuration and uses a coiled, single mode fiber amplifier 2 to amplify the seed pulse from a pulsed laser diode 4. The seed laser is a known diode laser capable of operating at a wavelength of 1064 nm. The output pulse from the seed laser 4 is fiber coupled and directed to an optical isolator 6, such as a polarization dependent isolator known in the art. Light from the isolator is coupled to the fiber amplifier by a wavefront division multiplexer (WDM) 8. The WDM 8 also couples pump light from a pump laser 10 into the fiber amplifier 2 in a first direction. A second WDM 12 directs light from a second pump laser 10 into the fiber amplifier 2 from the opposite direction. The WDM's also prevent backward traveling ASE from the amplifier to the 980 nm pumps and avoid terminal damage. The pump laser preferably operates at 980 nm and 200 mW and is a single mode solid state laser controlled by a timing circuit 24, as will be described in more detail below.

[0021] Each of the components to be described herein is optically connected to one or more other components by coupler fibers to provide the fully integrated laser fiber system. The coupler fibers are shown in the drawings by solid or broken lines as is conventional, and splices between individual fibers are indicated by squares.

[0022] To provide measurement of the power in the system, a tap 14 is used to direct a small amount of the seed laser energy to a photodetector 16. Additional taps may also be provided as will be described.

[0023] Fiber amplifier 2 is preferably 61 . . . 1 m in core diameter, Yb doped single mode fiber of 15-20 meters in length.

[0024] The amplified light pulse is directed to the second stage of the system (FIG. 3) through a filter isolator 18 containing a narrow band filter to suppress ASE noise to transmit into the amplifier.

[0025] FIG. 3 shows the second stage of a preamplifier in accordance with the invention. The amplified light obtained from the first stage of the preamplifier shown in FIG. 2 is directed to the input of an acoustic optical modulator (AOM) 20, which acts as a time gated filter to eliminate unwanted wavelengths. AOM 20 is preferably tuned to the pulse frequency of the seed laser. The AOM 20 is operated by a RF driver 22, which is in turn controlled by control circuit 24. The control circuit controls the operation of the several elements by providing control signals to the seed laser, the pump lasers, and other components in the system. A tap 26 and photodetector 28 may be provided in this stage also.

[0026] The second stage of the preamplifier comprises a coiled, clad-pumped fiber amplifier 30. This fiber amplifier is preferably of 10 μm core diameter and 125 μm cladding. Light from the first preamplifier stage is transmitted from the AOM filter to second stage of the preamplifier by a mode field adaptor (MFA) 32, which matches the modes passed through the AOM to the fiber amplifier 30 for further amplification.

[0027] The fiber amplifier 30 is clad pumped by directing pulsed pump light from a pump laser 34, to the cladding of the amplifier 30 through a 2x2 coupler 36. The pump light is transmitted through a short wave pass filter to prevent the forward traveling ASE and signal from damaging the pump

laser. In the preferred embodiment, the pump is a 915 nm, 5 W multimode fiber coupled pump source.

[0028] Amplified light from the fiber amplifier **30** is directed to the power amplifier stages through a filter/isolator **40** comprising a 5 nm narrow band 1064 nm filter.

[0029] Referring now to FIG. **4**, the light signal from the second stage of the preamplifier as illustrated in FIG. **3** is directed to the first stage of a power amplifier. The light is first directed to a number of splitters for dividing the light into a plurality of channels. In the embodiments shown, the light from the preamplifier is divided among seven channels. The first splitter **42** is a 2x2 splitter that divides the incoming light into two parts of approximately equal power. The remaining splitters **44** are preferably 2x1 splitters that divide the light into seven beams of approximately equal power and an eighth beam of about 1% for power monitoring by photodetector **46**. By this arrangement, the light from the preamplifier is divided into several parallel channels for simultaneous amplification while maintaining the desired qualities of the beam, namely low mode and high power. It will be understood that more or fewer than seven channels may be used.

[0030] Each output from a splitter **44** is directed to a first-stage fiber laser power amplifier **48** through a mode field adaptor **50**. In this stage, the laser power amplifier is preferably clad pumped amplifier having a 30 μm core diameter and a 250 μm cladding diameter. The fiber is coiled to suppress unwanted modes.

[0031] It will be appreciated that a feature of the invention is that the core diameter of the fiber amplifier increases in each subsequent stage. Thus, the core diameter in the preamplifier stage 2 is 10 μm , the core diameter in the first power amplifier stage is 30 μm , and the diameter in the second power amplifier stage is 115 μm . Mode field adaptors **50** are provided to match the 10 μm fibers from splitters **44** to the 30 μm core of the amplifiers **48** to provide mode control.

[0032] Each of the fiber amplifiers is pulse pumped by pumping laser **52**, which is a diode laser preferably operating at 915 nm and total power of 200 watts with each fiber having 50 watts. The several fiber laser amplifiers **48** are provided with light from the pump laser by dividing the light from the pump laser among several fibers **56** by splitters **54**. Pump light from laser is directed into the cladding of the fiber amplifiers **48** through tapered fiber bundles (TFB) **58**.

[0033] Amplified light output from the fiber amplifiers **48** is directed to the final stage of amplification through filter/isolators **60**.

[0034] FIG. **5** illustrates stage 2 of the power amplifier, which is the final stage of amplification in the preferred embodiment. Light from the several channels shown in FIG. **4** is coupled to a like number of laser fiber power amplifiers **64** in stage 2 by mode field adaptors **62**. The laser fiber amplifiers **64** preferably comprise 115 μm core, 350 μm cladding fibers. The mode field adaptors **62** match the 30 nm diameters of the fibers connecting the first and second power amplifier stages to the 115 μm diameters of the fiber amplifiers **64**.

[0035] Pumping light from diode lasers **66** is provided to the second stage power amplifiers **64** through tapered fiber bundles **68**. Diode lasers **66** preferably operate at 915 nm and 200 W and produce a plurality of output channels that are directed to the TFB **68**.

[0036] The output beams from the power amplifiers **64** are directed along output fibers **70** to a beam combiner **72**, which represents the output of the system.

[0037] FIG. **6** illustrates the preferred timing for the system described above. Channel A shows the pulse provided by control circuit **24** to the seed diode driver **74** that controls the seed diode **4**. Channel B represents the signal provided to the diode driver **76** that controls the stage one preamplifier pump diodes. Channel C illustrates the signal provided to the AOM **20** in FIG. **3**. Channel D illustrates the signal provided to the preamplifier stage 2 diode driver **78** for the pump laser **34**. Channel E represents the signal pulses provided to the diode driver **80** for the pump laser **52**. Channel F represents the signal pulses provided to the diode driver **82** for the pump lasers **66**.

What is claimed is:

1. A fiber laser amplifier comprising:

- a seed laser configured to produce a seed pulse at a pulse repetition rate of about 10 Hz to about 10 KHz;
- a fiber preamplifier configured to receive and amplify the seed pulse, the fiber preamplifier having a first core diameter;
- a fiber power amplifier comprising a low numerical aperture, coiled clad fiber, having a core diameter larger than the first core diameter; and
- a coupler configured to couple the fiber preamplifier to the fiber power amplifier.

2. The fiber laser amplifier according to claim 1, wherein the low numerical aperture is between about 0.06 and 0.08.

3. The fiber laser amplifier according to claim 1, further comprising a tapered fiber bundle connected to a cladding of the fiber power amplifier configured to direct pump energy into the cladding.

4. The fiber laser amplifier according to claim 1, further comprising:

- a first pumping device configured to pump the fiber preamplifier,
- a second pumping device configured to pump the fiber power amplifier; and
- a synchronizing device configured to synchronize the seed pulse with the pumping devices.

5. The fiber laser amplifier according to claim 1, further comprising one or more additional power amplifiers, wherein the core diameter of each additional power amplifier increases with each subsequent power amplifier stage.

6. A pulsed fiber laser comprising:

- a seed laser configured to produce a seed pulse at a pulse repetition rate of about 10 Hz to about 10 KHz;
 - a first amplifier configured to receive and amplify the seed pulse, the first amplifier having a first core diameter;
 - a second amplifier comprising coiled clad fiber having a second core diameter, the second core diameter being larger than the first core diameter; and
 - a coupler configured to couple the first and second amplifiers;
- wherein core diameters of the second amplifier and subsequent amplifiers increase with each subsequent amplifier stage.

7. The pulsed fiber laser of claim 6, further comprising a tapered fiber bundle connected to a cladding of the second amplifier configured to direct pump energy into the cladding.

8. The pulsed fiber laser of claim 6, further comprising:

- a first pumping device configured to pump the first amplifier,
- a second pumping device configured to pump the second amplifier, and

- a synchronizing device configured to synchronize the seed pulse with the pumping devices.
- 9. The pulsed fiber laser of claim 6, wherein the fiber of the second amplifier comprises a low numerical aperture.
- 10. A fiber preamplifier, comprising:
 - a first fiber preamplifier stage configured to receive and amplify a seed pulse produced by a seed laser at a pulse repetition rate of about 10 Hz to about 10 KHz, the first fiber preamplifier stage comprising a first core diameter;
 - a second fiber preamplifier stage configured to receive the amplified seed pulse, the second fiber preamplifier stage comprising a second core diameter and an acoustic optical modulator (AOM); and
 - a filter isolator located between the first fiber preamplifier stage and the second fiber preamplifier stage, the filter isolator configured to suppress noise from the first fiber preamplifier stage;
 wherein the second core diameter is larger than the first core diameter.
- 11. The fiber preamplifier of claim 10, further comprising:
 - a first pumping device configured to pump the first fiber preamplifier stage;
 - a second pumping device configured to pump the second fiber preamplifier stage; and
 - a synchronizing device configured to synchronize the seed pulse with the pumping devices.
- 12. The fiber preamplifier of claim 10, wherein the first fiber preamplifier stage further comprises:
 - an optical isolator configured to receive and optically isolate the seed pulse;
 - a coiled, single-mode fiber amplifier having the first core diameter and configured to receive the optically isolated seed pulse;
 - a first wavefront division multiplexer configured to couple the optically isolated seed pulse and pump light from a first pumping device to the coiled, single-mode fiber amplifier in a first direction; and

- a second wavefront division multiplexer configured to couple pump light from a second pumping device to the coiled, single-mode fiber amplifier in a second direction.
- 13. The fiber preamplifier of claim 12, wherein the second direction is opposite the first direction.
- 14. The fiber preamplifier of claim 10, wherein the filter isolator further comprises a narrow band filter configured to suppress amplified spontaneous emission noise.
- 15. The fiber preamplifier of claim 10, wherein the AOM is a time gated filter and is configured to receive the amplified seed pulse and eliminate unwanted wavelengths from the amplified seed pulse.
- 16. The fiber preamplifier of claim 15, wherein the AOM is tuned to a pulse frequency of the seed laser.
- 17. The fiber preamplifier of claim 10, further comprising:
 - a coiled, clad-pumped fiber amplifier having the second core diameter; and
 - a mode field adapter located between the AOM and the coiled, clad-pumped fiber amplifier, the mode field adapter configured to match modes of the amplified seed pulse to the coiled, clad-pumped amplifier for further amplification of the amplified seed pulse.
- 18. The fiber preamplifier of claim 17, further comprising:
 - a pumping device configured to provide pulsed pump light; and
 - a coupler configured to direct the pulsed pump light from the pumping device to a cladding of the coiled, clad-pumped fiber amplifier.
- 19. The fiber preamplifier of claim 18, further comprising:
 - a short wave pass filter coupled between the pumping device and the cladding of the coiled, clad-pumped fiber amplifier,
 wherein the short wave pass filter is configured to prevent forward traveling amplified spontaneous emission from damaging the pumping device.
- 20. The fiber preamplifier of claim 10, further comprising:
 - a radio frequency (RF) driver configured to control operation of the AOM.

* * * * *