



US006748131B2

(12) **United States Patent**
Steinberg et al.

(10) **Patent No.:** US 6,748,131 B2
(45) **Date of Patent:** Jun. 8, 2004

(54) **OPTICAL WAVEGUIDE DEVICES AND METHODS OF FABRICATING THE SAME**

(75) Inventors: **Dan A. Steinberg**, Blacksburg, VA (US); **David W. Sherrer**, Blacksburg, VA (US); **Mindaugas F. Dautartas**, Radford, VA (US); **Donald E. Leber**, Radford, VA (US)

(73) Assignee: **Shibley Company, L.L.C.**, Marlborough, MA (US)

(*) Notice: Subject to any disclaimer, the term of this patent is extended or adjusted under 35 U.S.C. 154(b) by 0 days.

(21) Appl. No.: **09/860,825**

(22) Filed: **May 21, 2001**

(65) **Prior Publication Data**

US 2002/0028037 A1 Mar. 7, 2002

Related U.S. Application Data

(60) Provisional application No. 60/205,671, filed on May 19, 2000.

(51) **Int. Cl.⁷** **G02B 6/26**; G02B 6/35; G02B 6/36

(52) **U.S. Cl.** **385/20**; 385/22; 385/23; 385/50; 385/52

(58) **Field of Search** 385/20-23, 25, 385/50, 52; 365/16, 23, 50, 52, 33-35

(56) **References Cited**

U.S. PATENT DOCUMENTS

- 3,864,018 A 2/1975 Miller
- 4,120,923 A 10/1978 Kloker et al.
- 4,150,870 A 4/1979 d'Auria
- 4,165,496 A 8/1979 Di Domenico, Jr. et al.
- 4,176,908 A 12/1979 Wagner
- 4,210,923 A 7/1980 North et al.
- 4,225,213 A 9/1980 McBride, Jr. et al.
- 4,296,995 A 10/1981 Bickel
- 4,325,604 A 4/1982 Witte

- 4,407,562 A 10/1983 Young
- 4,415,229 A 11/1983 McCullough
- 4,498,730 A 2/1985 Tanaka et al.
- 4,639,074 A 1/1987 Murphy
- 4,699,457 A 10/1987 Goodman
- 4,725,114 A 2/1988 Murphy
- 4,756,590 A 7/1988 Forrest et al.
- 4,859,022 A 8/1989 Opdahl et al.
- 4,900,118 A 2/1990 Yanagawa et al.
- 4,932,745 A 6/1990 Blonder
- 4,973,127 A 11/1990 Cannon, Jr. et al.
- 5,044,711 A 9/1991 Saito
- 5,123,073 A 6/1992 Pimpinella
- 5,127,084 A 6/1992 Takahashi
- 5,135,590 A 8/1992 Basavanhally et al.
- 5,177,804 A 1/1993 Shimizu et al.
- 5,179,609 A 1/1993 Blonder et al.
- 5,181,216 A 1/1993 Ackerman et al.
- 5,185,825 A 2/1993 Shigematsu et al.
- 5,185,846 A 2/1993 Basavanhally et al.
- 5,187,758 A 2/1993 Ueda et al.

(List continued on next page.)

FOREIGN PATENT DOCUMENTS

JP 6385522 4/1988

Primary Examiner—David V. Bruce

Assistant Examiner—Krystyna Suchecki

(74) *Attorney, Agent, or Firm*—Niels Haun; Jonathan D. Baskin

(57) **ABSTRACT**

A first waveguide holding member has a first transverse surface region and a first optical waveguide having an end terminating at the first transverse surface region. A second waveguide holding member has a second transverse surface region which confronts the first transverse surface region of the first waveguide holding member and a second optical waveguide having an end terminating at the second transverse surface region. A guide member is operatively coupled to the first and second waveguide holding members and guides the first waveguide holding member in a transverse direction relative to the second waveguide holding member so as to selectively optically couple and decouple the ends of the first and second optical waveguides.

5 Claims, 13 Drawing Sheets

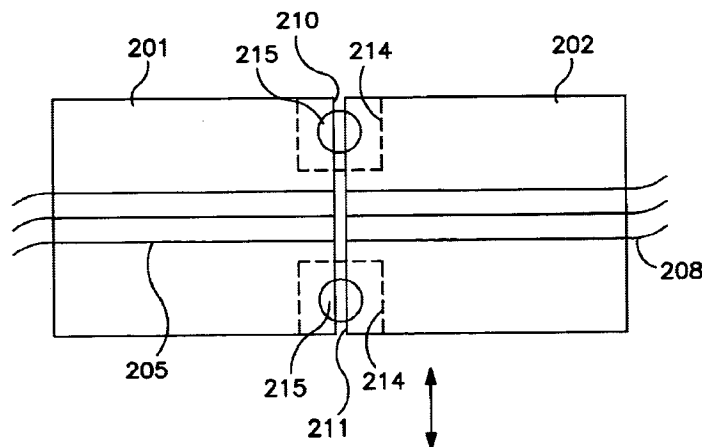

U.S. PATENT DOCUMENTS				
5,257,332 A	10/1993	Pimpinella	5,828,800 A	10/1998 Henry et al.
5,297,228 A	3/1994	Yanagawa et al.	5,901,262 A	5/1999 Kobayashi et al.
5,337,384 A	8/1994	Basavanhally et al.	5,909,524 A	6/1999 Tabuchi
5,357,590 A	* 10/1994	Auracher 385/33	5,920,665 A	7/1999 Presby
5,379,361 A	1/1995	Maekawa et al.	6,045,270 A	4/2000 Weiss et al.
5,390,266 A	2/1995	Heitmann et al.	6,056,696 A	5/2000 Kallman
5,440,655 A	8/1995	Kaplow et al.	6,064,781 A	5/2000 Seibold et al.
5,461,683 A	10/1995	Harman	6,101,299 A	8/2000 Laor
5,483,608 A	1/1996	Yokomachi et al.	6,118,917 A	9/2000 Lee et al.
5,499,309 A	3/1996	Kozuka et al.	6,160,936 A	12/2000 You et al.
5,500,910 A	3/1996	Boudreau et al.	6,234,687 B1	5/2001 Hall et al.
5,500,911 A	* 3/1996	Roff 385/33	6,320,997 B1	11/2001 Dautartas et al.
5,555,333 A	9/1996	Kato	6,328,479 B1	12/2001 Schofield et al.
5,566,262 A	10/1996	Yamane et al.	6,393,174 B1	5/2002 Karaguleff et al.
5,568,585 A	10/1996	Kramer	6,393,175 B1	5/2002 Jurbergs et al.
5,602,951 A	2/1997	Shiota et al.	6,477,303 B1 *	11/2002 Witherspoon 385/52
5,611,006 A	3/1997	Tabuchi	6,519,382 B1	2/2003 Jurbergs et al.
5,623,564 A	4/1997	Presby	2001/0041026 A1	11/2001 Steinberg et al.
5,699,463 A	12/1997	Yang et al.	2002/0025104 A1	2/2002 Steinberg et al.
5,732,167 A	3/1998	Ishiko et al.	2002/0025107 A1	2/2002 Heiks et al.
5,778,123 A	7/1998	Hagan et al.	2002/0146194 A1	10/2002 Sherrer et al.
5,785,825 A	7/1998	Hwang et al.	2003/0108272 A1	6/2003 Sherrer et al.

* cited by examiner

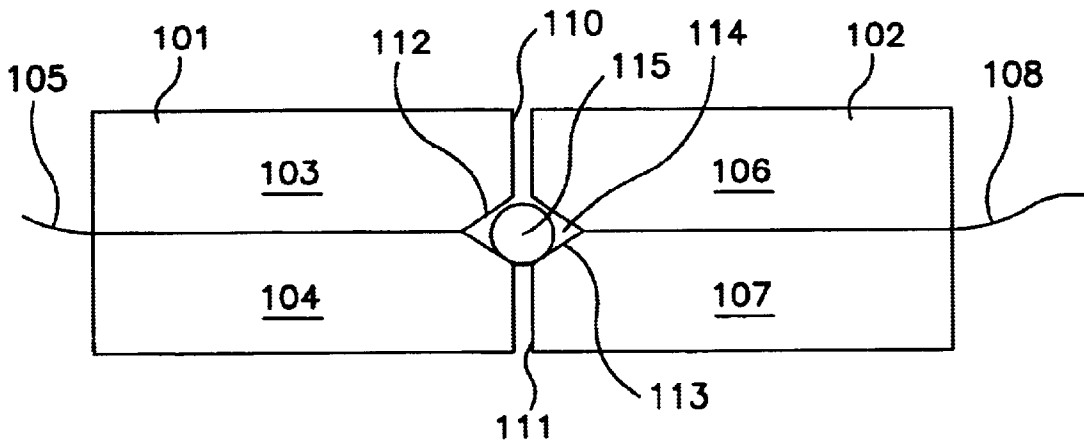

FIG. 1

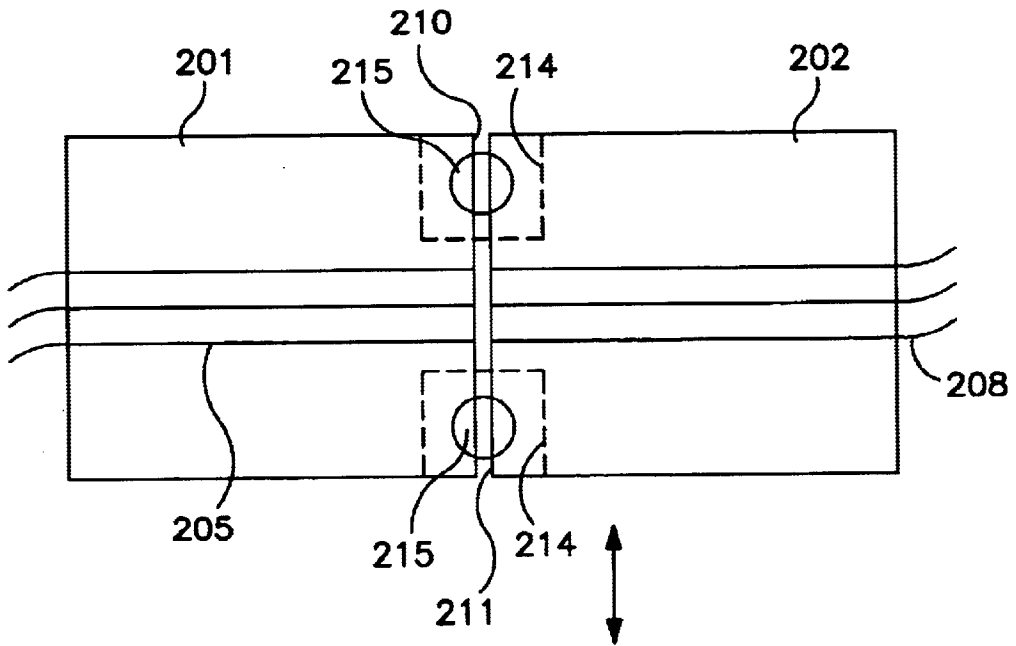

FIG. 2

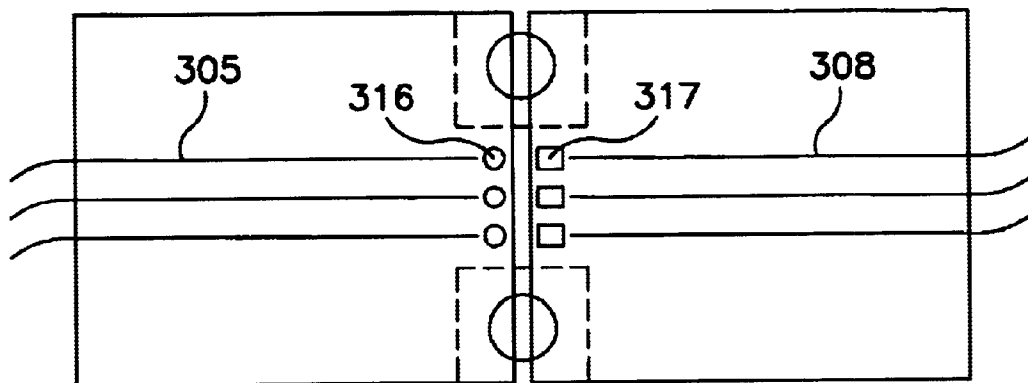

FIG. 3

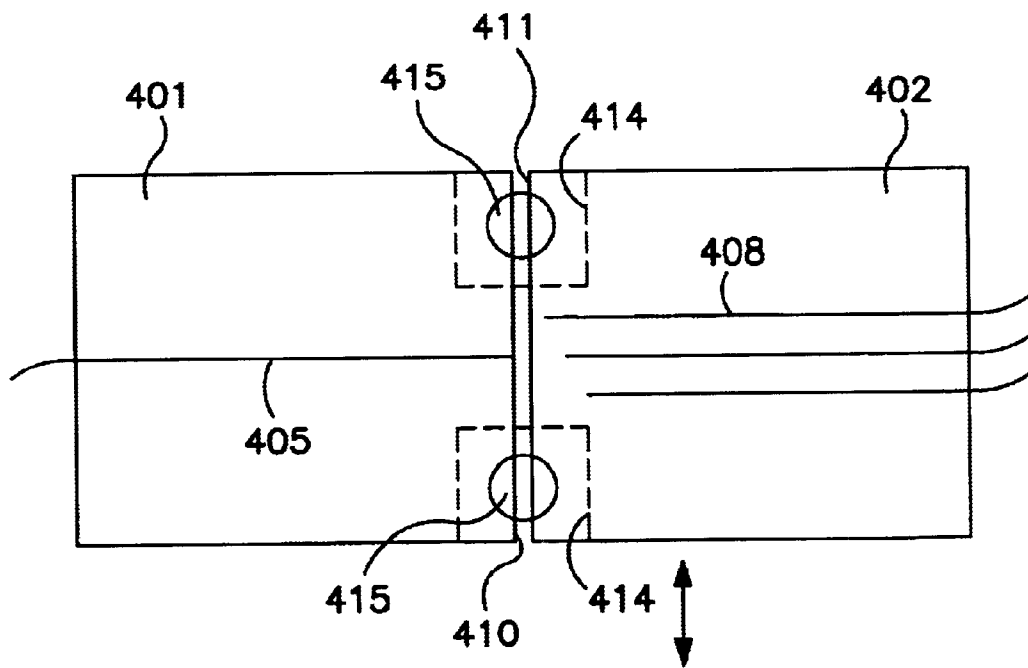

FIG. 4

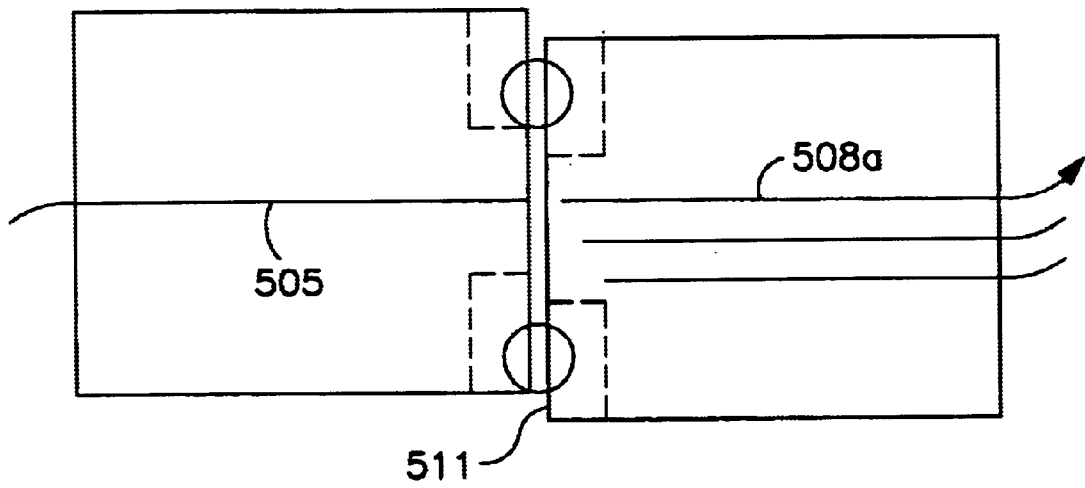

FIG. 5

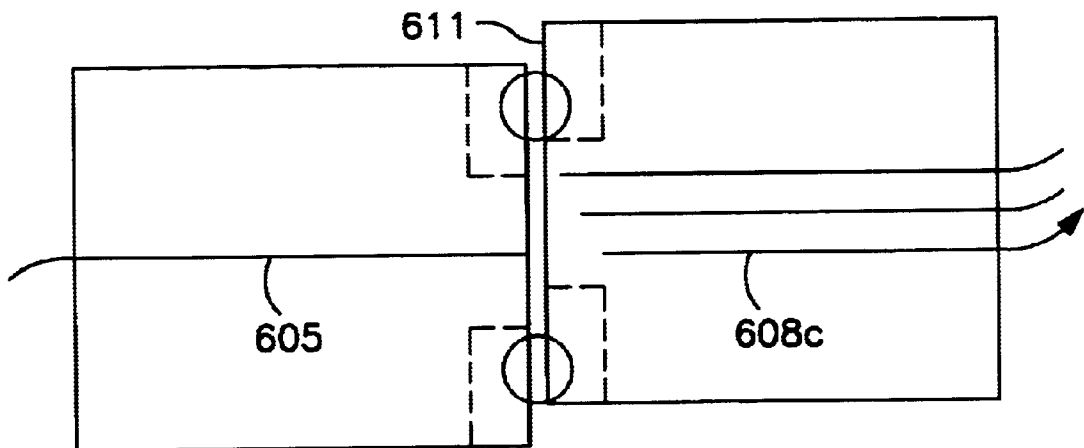

FIG. 6

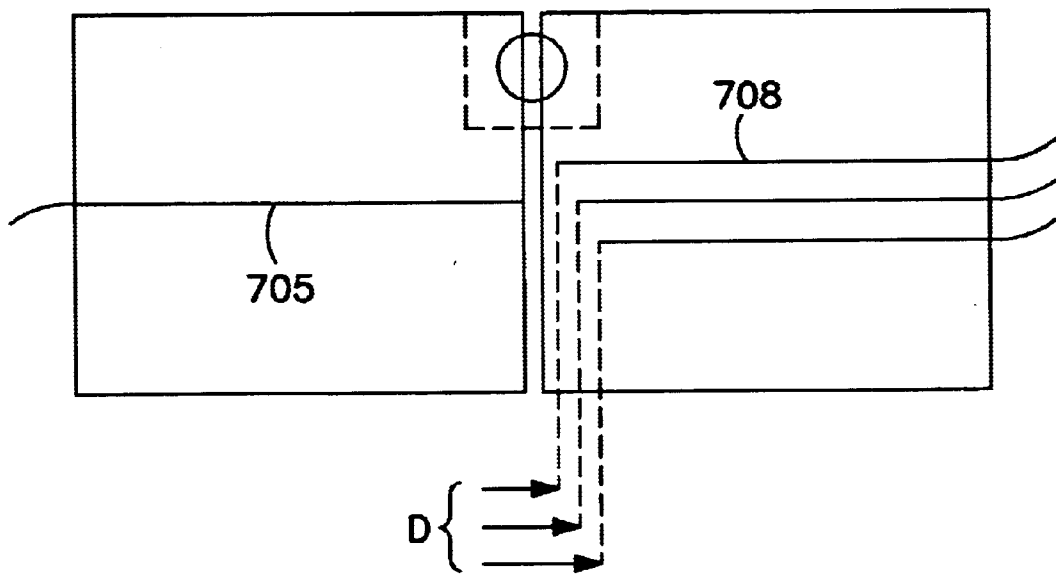

FIG. 7

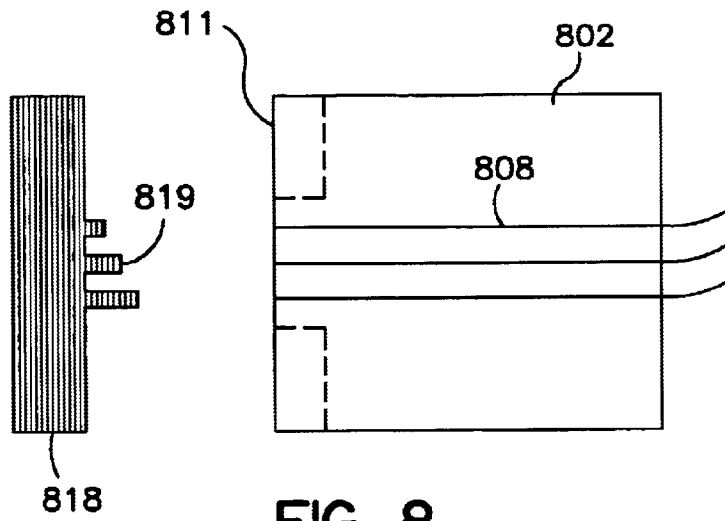

FIG. 8

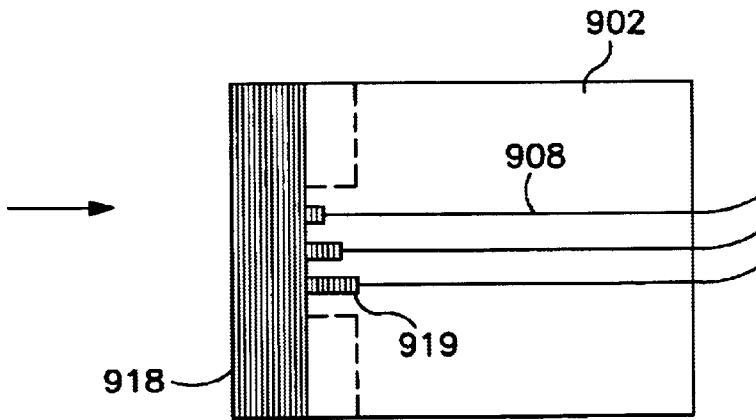

FIG. 9

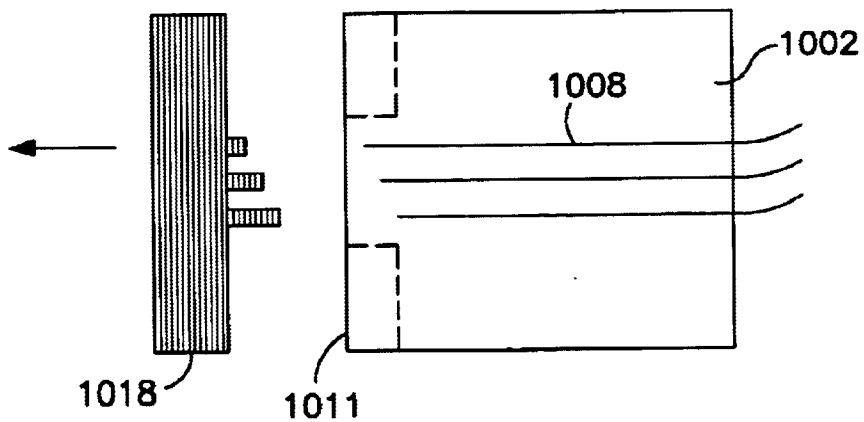

FIG. 10

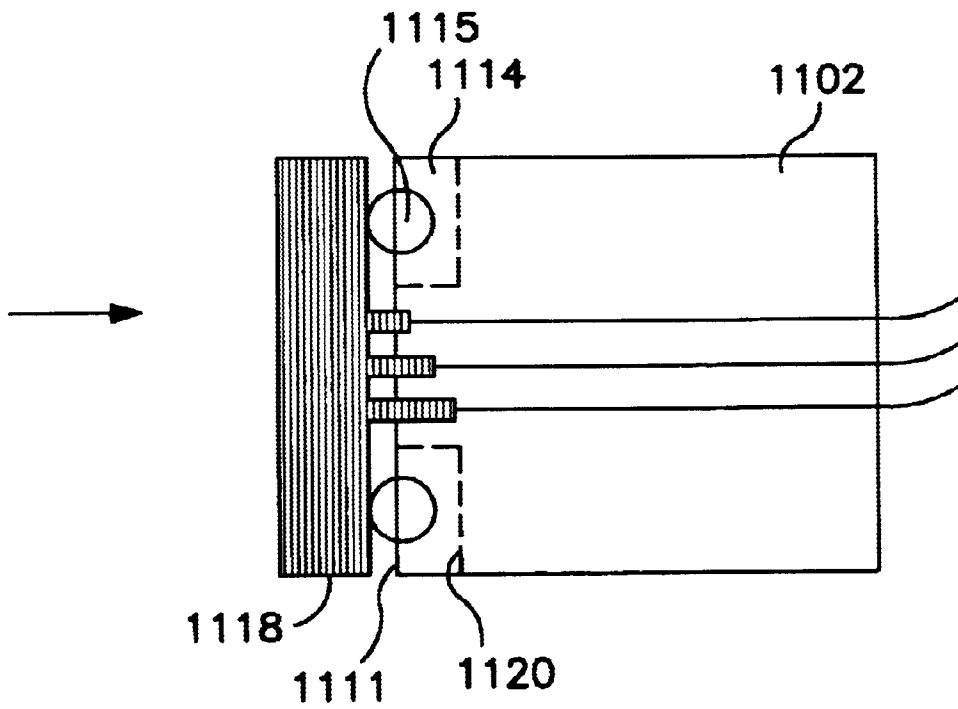

FIG. 11

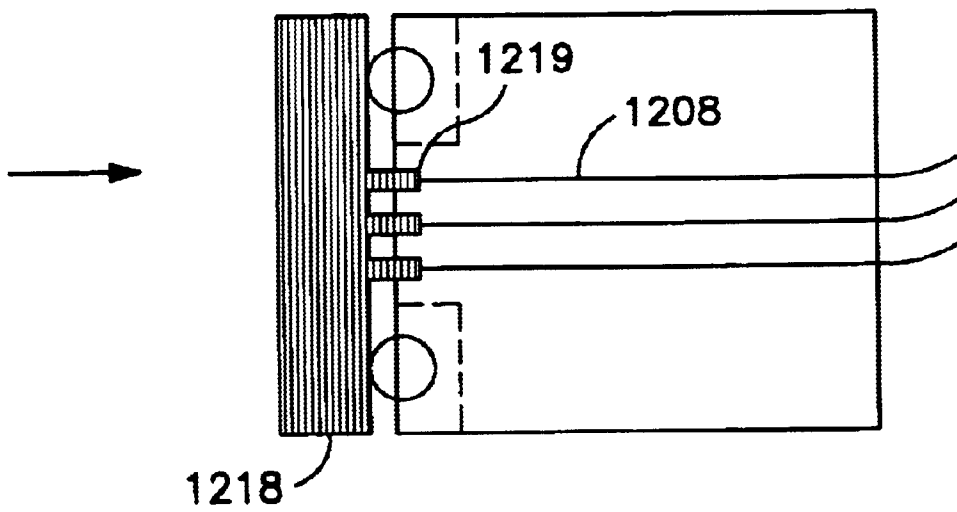

FIG. 12

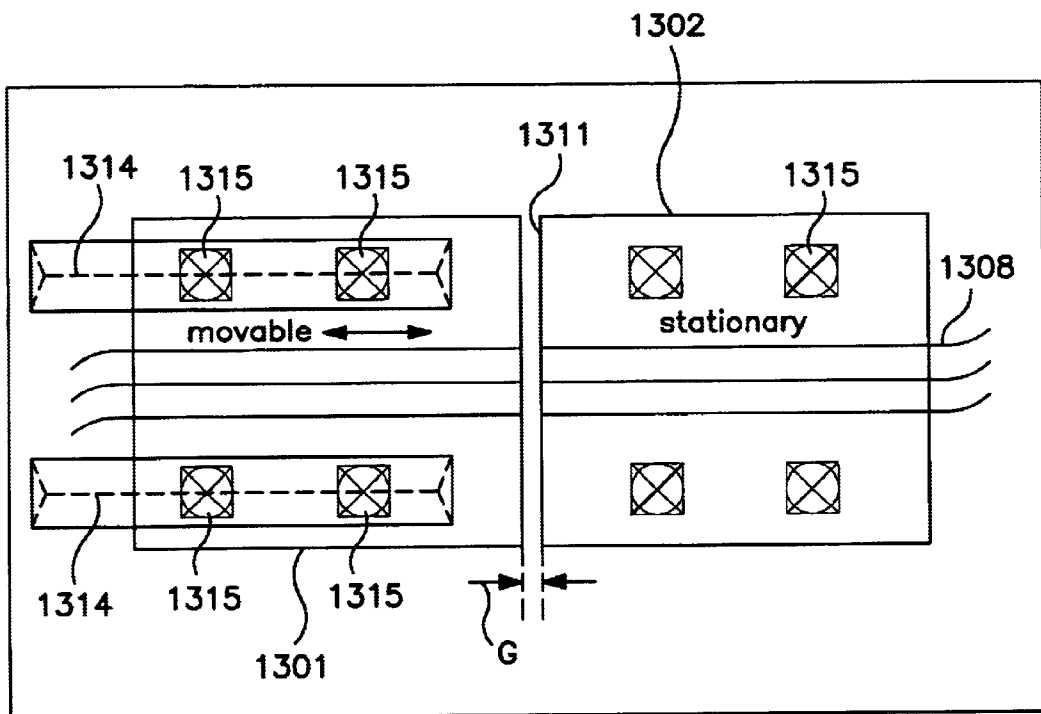

FIG. 13

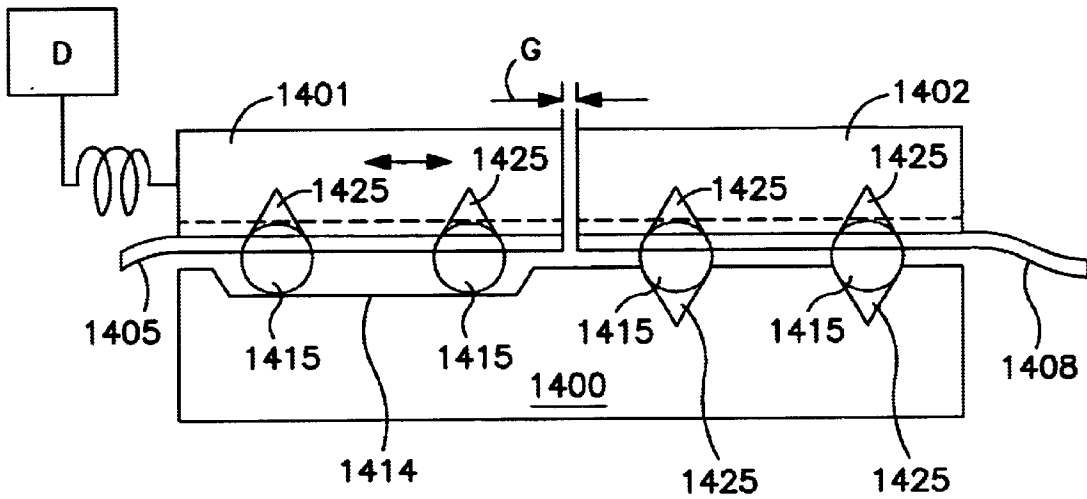

FIG. 14

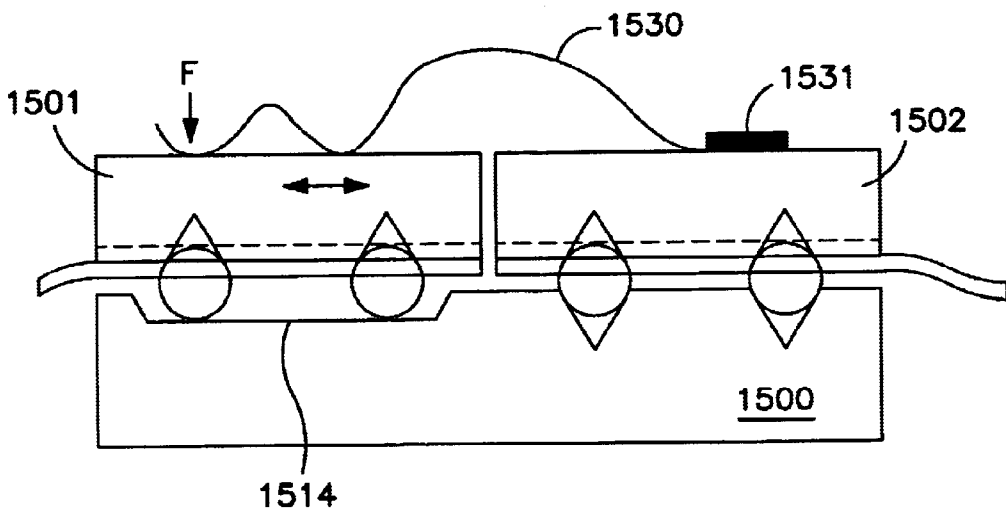

FIG. 15

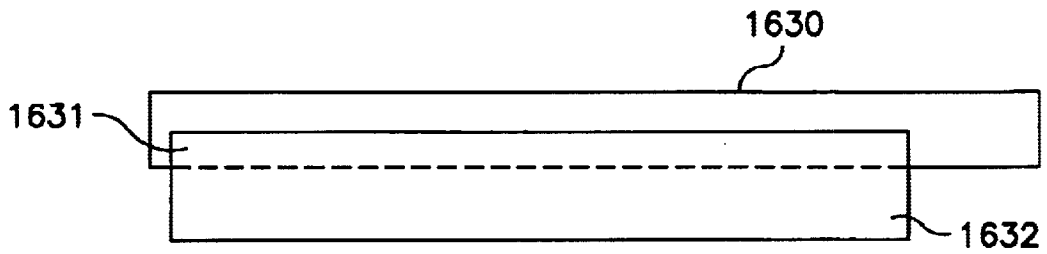

FIG. 16

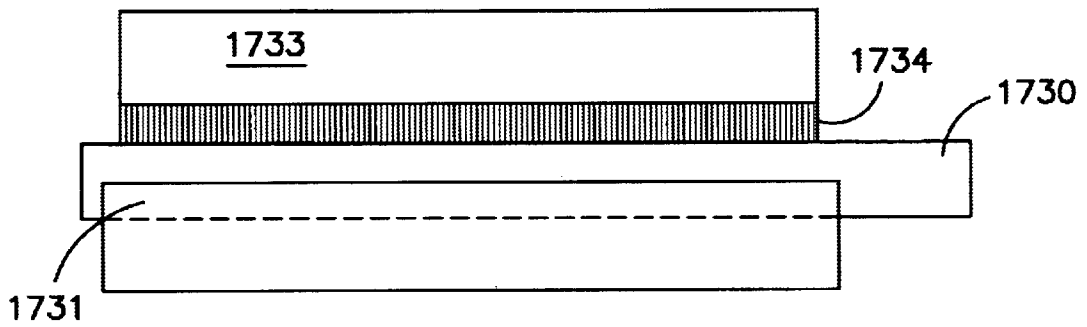

FIG. 17

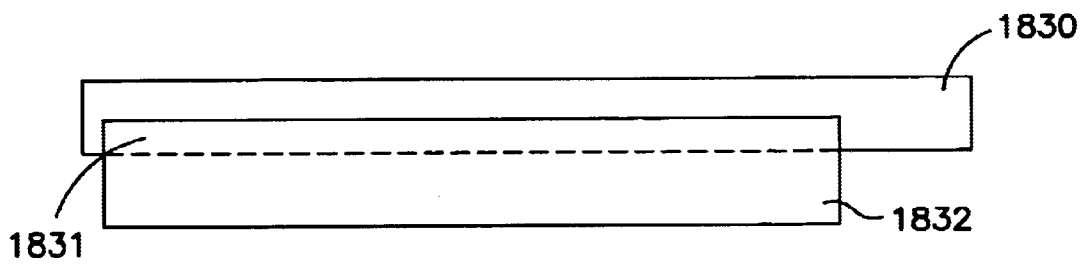

FIG. 18

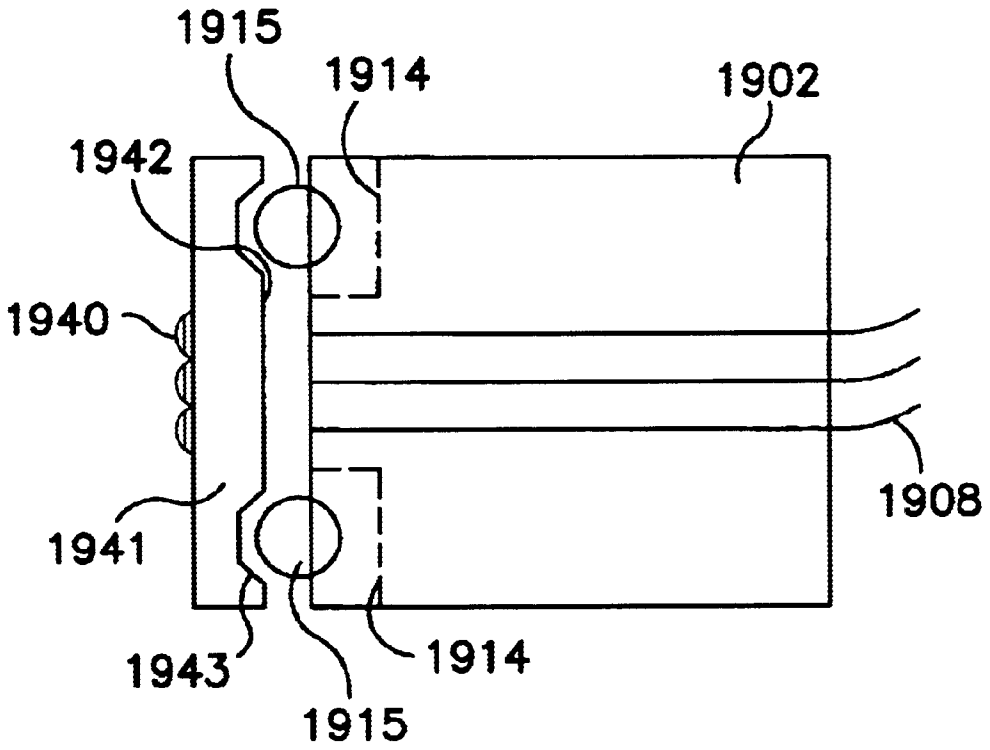

FIG. 19

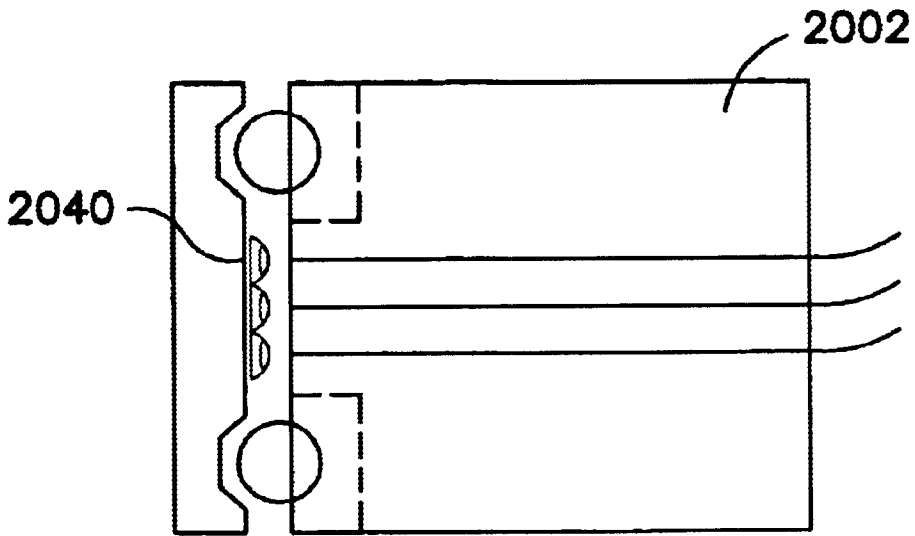

FIG. 20

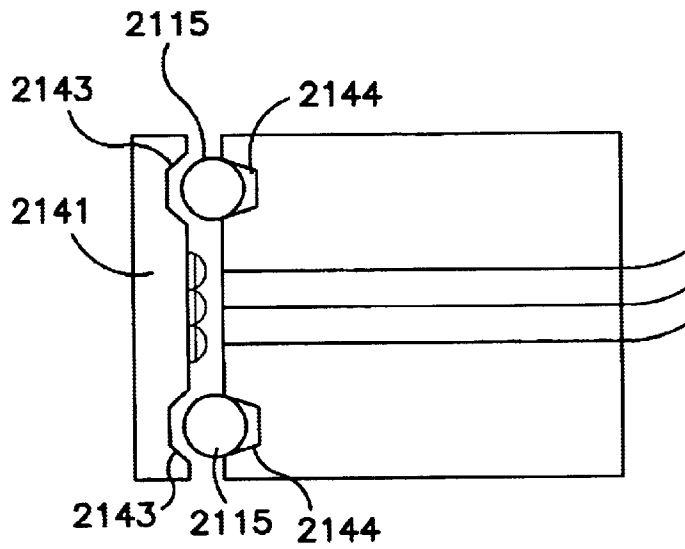

FIG. 21

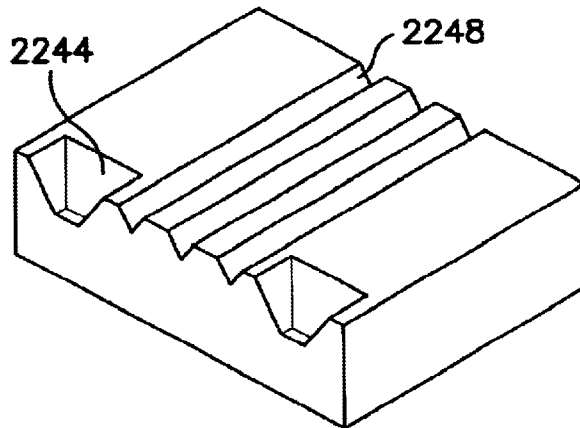

FIG. 22

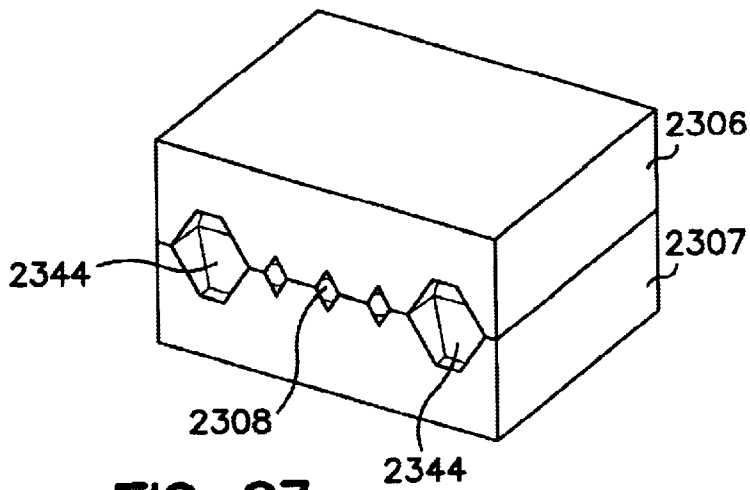

FIG. 23

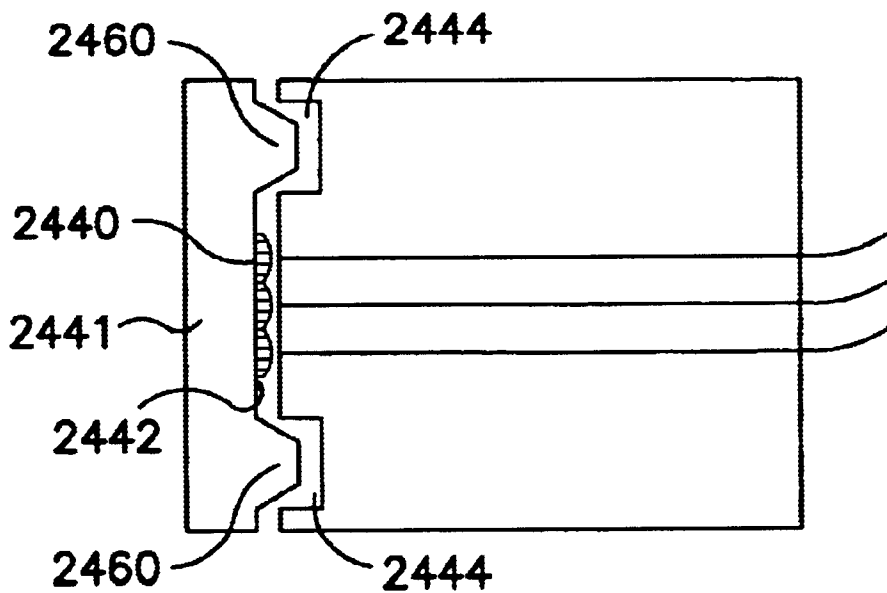

FIG. 24

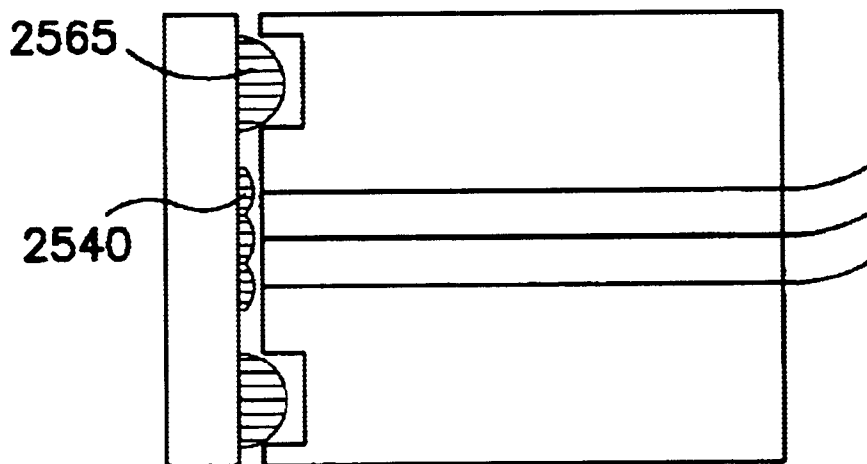

FIG. 25

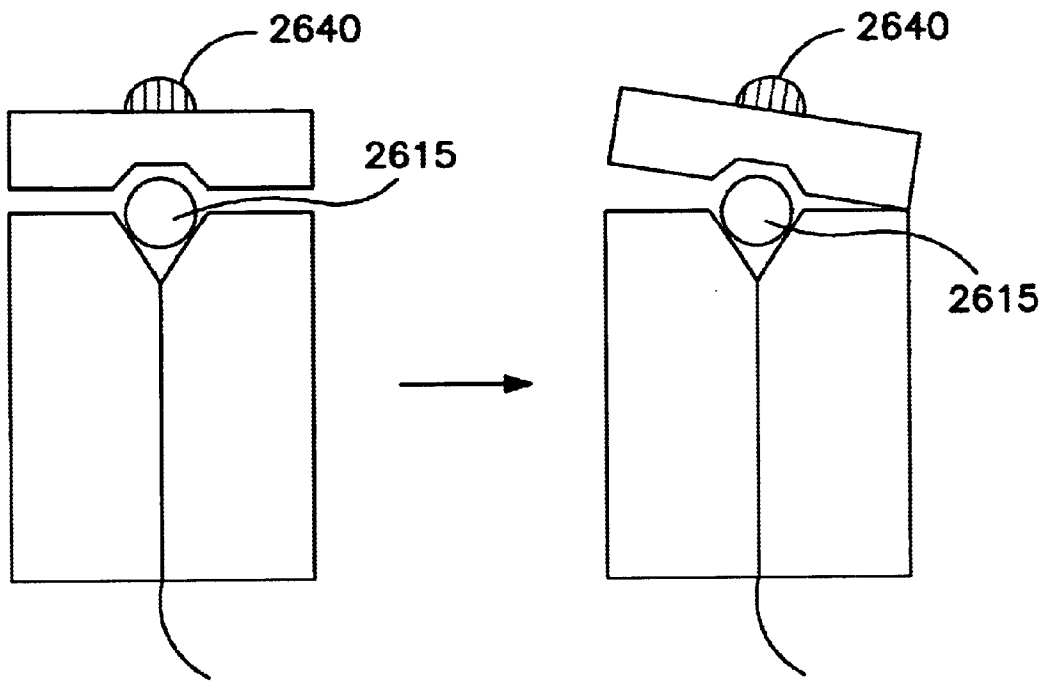

FIG. 26

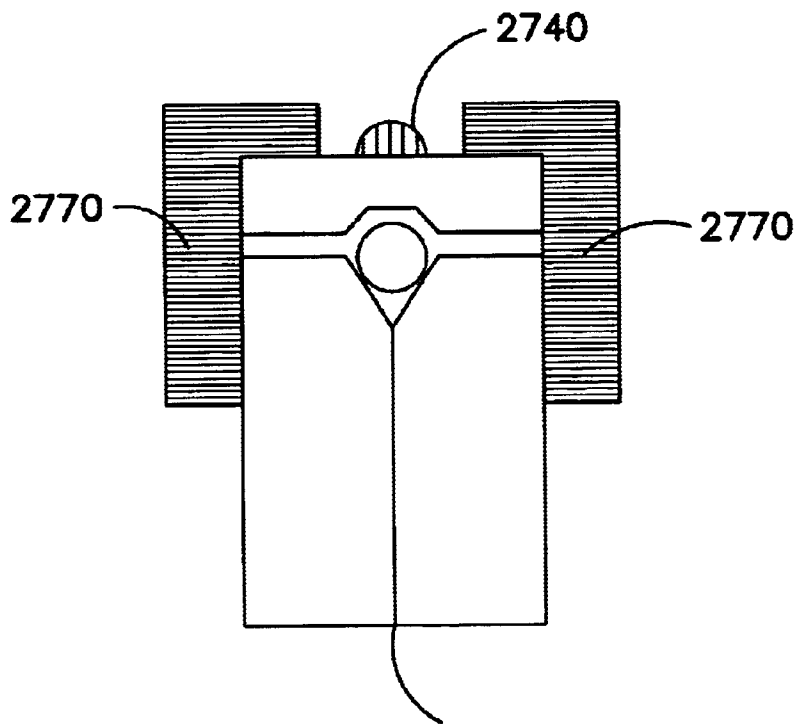

FIG. 27

OPTICAL WAVEGUIDE DEVICES AND METHODS OF FABRICATING THE SAME

CROSS-REFERENCE TO RELATED APPLICATIONS

Priority is claimed to U.S. Provisional Application Ser. No. 60/205,671, filed May 19, 2000, the entirety of which is incorporated herein by reference.

BACKGROUND OF THE INVENTION

Field of the Invention

The present invention generally relates to optical devices, and more particularly, the present invention relates to optical waveguide switches, variable optical attenuators, and combination waveguide and lenslet arrays.

BACKGROUND OF THE INVENTION

The increasing demand for high-speed voice and data communications has led to an increased reliance on optical communications, particularly optical fiber communications. The use of optical signals as a vehicle to carry channeled information at high speeds is preferred in many instances to carrying channeled information at other electromagnetic wavelengths/frequencies in media such as microwave transmission lines, co-axial cable lines and twisted pair transmission lines. Advantages of optical media are, among others, high-channel (bandwidth), greater immunity to electromagnetic interference, and lower propagation loss. In fact, it is common for high-speed optical communication system to have signal rates in the range of approximately several Giga bits per second (Gbit/sec) to approximately several tens of Gbit/sec.

One way of carrying information in an optical communication system, for example an optical network, is via an array of optical fibers. Ultimately, the optical fibers may be coupled to another array of waveguides, such as another optical fiber array, or a waveguide array of an optoelectronic integrated circuit (OEIC). In order to assure the accuracy of the coupling of the fiber array to another waveguide array, it becomes important to accurately position each optical fiber in the array.

Optical switches serve a variety of applications in optical communication systems. One type of such optical switches are mechanical switches. Mechanical optical switches have been used in a variety of optical fiber routing applications to switch between particular optical signal pads to provide reliable optical transmission routes for carrying optical signals.

SUMMARY OF THE INVENTION

According to an exemplary embodiment of the present invention, an optical switch includes a first waveguide holding member having a first transverse surface region and a first optical waveguide having an end terminating at the first transverse surface region, and a second waveguide holding member having a second transverse surface region which confronts the first transverse surface region of the first waveguide holding member and a second optical waveguide having an end terminating at the second transverse surface region. A guide member is operatively coupled to the first and second waveguide holding members and guides the first waveguide holding member in a transverse direction relative to the second waveguide holding member so as to selectively optically couple and decouple the ends of the first and

second optical waveguides. The guide member includes a plurality of first recesses formed in the first transverse surface region of the first waveguide holding member, a plurality of second recesses formed in the second transverse surface region of the second waveguide holding member and confronting the plurality of first recesses to define a respective plurality of cavities therebetween, and a plurality of guide balls contained with the plurality of cavities, respectively.

According to another exemplary embodiment of the present invention, an optical switch includes a first waveguide holding member having a first transverse surface region and a first optical waveguide, and a second waveguide holding member having a second transverse surface region which confronts the first transverse surface region of the first waveguide holding member and a second optical waveguide. A first lens is optically coupled to an end of the first optical waveguide and located at the first transverse surface region of the first waveguide holding member, and a second lens is optically coupled to an end of the second optical waveguide and located at the second transverse surface region of the second waveguide holding member. A guide member guides the first waveguide holding member in a transverse direction relative to the second waveguide holding member so as to selectively optically couple and decouple the first and second lenses.

According to another exemplary embodiment of the present invention, a variable optical attenuator includes a first waveguide holding member having a first transverse surface region and a first optical waveguide having an end terminating at the first transverse surface region, and a second waveguide holding member having a second transverse surface region which confronts the first transverse surface region of the first waveguide holding member and a plurality of second optical waveguides. The plurality of second optical waveguides have respective ends which terminate at respectively different distances from the second transverse surface region. A guide member guides the first waveguide holding member in a transverse direction relative to the second waveguide holding member so as to selectively optically couple and decouple the end of the first optical waveguide to one of the respective ends of the plurality of second optical waveguides.

According to still another exemplary embodiment of the present invention, a method of fabricating a variable optical attenuator includes placing a first optical waveguide on a first waveguide holding member such that an end of the first optical waveguide terminates at a transverse surface region of the first waveguide holding member. Also, a plurality of pedestals of a tool are placed into a respective plurality of grooves of a second waveguide holding member at a transverse surface region of the second waveguide holding member. The ends of a plurality of second optical waveguides are aligned against respective ends of the plurality of pedestals within the plurality of grooves of the second waveguide holding member. The pedestals of the tool are extracted from the respective plurality of grooves of the second waveguide holding member. Then the first and second waveguide holding members are operatively coupled with a guide mechanism such that the transverse surface of the first waveguide holding member confronts the transverse surface of the second waveguide holding member, and such that the first waveguide holding member is movable in a transverse direction relative to the second waveguide holding member.

According to yet another exemplary embodiment of the present invention, a variable optical attenuator includes a first waveguide holding member having a first transverse

surface region and a first optical waveguide, and a second waveguide holding member having a second transverse surface region which confronts the first transverse surface region of the first waveguide holding member and a second optical waveguide. A guide member is operatively coupled to the first and second waveguide holding members and guides the first waveguide holding member in a longitudinal direction relative to the second waveguide holding member. Here, the longitudinal direction is perpendicular to the first and second transverse surface regions of the first and second waveguide holding members. A drive mechanism cooperates with the guide member to move the first waveguide holding member in the longitudinal direction relative to the second waveguide holding member so as to selectively increase and decrease a distance between first and second transverse surface regions of the first and second waveguide holding members.

According to another exemplary embodiment of the present invention, a method of fabricating an optical device includes placing an optical fiber lengthwise in a groove formed in surface of a waveguide holding member. A diameter of the optical fiber relative to a cross-sectional dimension of the groove is such that the optical fiber protrudes above the surface of the waveguide holding member along a length of the groove. A non-stick surface of a lid member is pressed against the optical fiber placed in the groove of the waveguide holding member and an adhesive is applied to the optical fiber and the groove. The adhesive is cured while the non-stick surface of the lid member is pressed against the optical fiber, and the non-stick surface of the lid member is then removed from the optical fiber.

According to yet another aspect of the present invention, an optical device includes a waveguide holding member having a first transverse surface region and an optical waveguide, and a lenslet array holding member having a second transverse surface region which confronts the first transverse surface region of the first waveguide holding member and a lenslet array. An alignment mechanism aligns an end of the optical waveguide relative to the lenslet array and is formed at the first and second transverse surface regions of the waveguide holding member and the lenslet array holding member, respectively.

BRIEF DESCRIPTION OF THE DRAWINGS

The invention is best understood from the following detailed description when read with the accompanying drawings. It is emphasized that the various features are not necessarily drawn to scale. In fact, the dimensions may be arbitrarily increased or decreased for clarity of discussion.

FIG. 1 is a side view of an optical switch according to an illustrative embodiment of the present invention.

FIG. 2 is a top view of the optical switch shown in FIG. 1.

FIG. 3 illustrates a modification of the embodiment of FIGS. 1 and 2 in which the ends of optical waveguides are terminated with ball lenses and/or GRIN lenses.

FIGS. 4-7 illustrate a variable attenuator according to another embodiment of the present invention.

FIGS. 8-10 illustrate use of a micro-machined tool as a fiber stop in the fabrication of the variable attenuator of FIGS. 4-7.

FIGS. 11 and 12 illustrate modifications of the use of the micro-machined tool of FIGS. 8-10.

FIGS. 13-14 illustrate a variable attenuator according to yet another embodiment of the present invention.

FIG. 15 illustrates an alternative embodiment of the variable attenuator of FIGS. 13-14.

FIGS. 16-18 illustrate a process of providing an open faced waveguide holding member according to another embodiment of the present invention.

FIGS. 19-27 illustrate further embodiments of present invention in which a lenslet array is provided in place of one of the waveguide holding members.

DETAILED DESCRIPTION OF THE PREFERRED EMBODIMENTS

In the following detailed description, for purposes of explanation and not limitation, exemplary embodiments disclosing specific details are set forth in order to provide a thorough understanding of the present invention. However, it will be apparent to one having ordinary skill in the art having the benefit of the present disclosure, that the present invention may be practiced in other embodiments that depart from the specific details disclosed herein. Moreover, descriptions of well-known devices, methods and materials may be omitted so as to not obscure the description of the present invention.

According to exemplary embodiments of the present invention, an optical switch includes a first waveguide holding member and a second waveguide holding member. The first waveguide holding member holds at least one first optical waveguide, and the second waveguide holding member holds at least one second optical waveguide. Advantageously, the first waveguide holding member moves transversely relative to the second waveguide holding member. The transverse motion enables selective coupling between the optical waveguides thereof. Other examples of such devices are described in commonly assigned U.S. patent application Ser. No. 09/835,106, filed Apr. 13, 2001, and entitled "OPTICAL WAVEGUIDE SWITCH", and in commonly assigned U.S. patent application Ser. No. 09/845,773, filed May 2, 2001, and entitled "OPTICAL WAVEGUIDE SWITCH". The contents of these applications are incorporated herein by reference in their entirety.

FIG. 1 is a side view of an optical switch 100 according to an illustrative embodiment of the present invention. The switch 100 generally includes a first waveguide holding member 101 and a second waveguide holding member 102. Although the first and second waveguide holding members 101 and 102 have identical structures in the present embodiments, these members 101 and 102 may instead be configured so as to have different structures. Reference numerals 110 and 111 denoted confronting and spaced apart transverse regions of the waveguide holding members 101 and 102, respectively.

The first waveguide holding member 101 is made up of a top chip 103 and a bottom chip 104. Optionally, the top chip 103 and the bottom chip 104 are made of silicon or a silicon containing material. Sandwiched between the top chip 103 and the bottom chip 104 are a plurality of optical waveguides 105 (e.g., optical fibers). Optionally, the optical waveguides 105 are contained within cavities defined by opposing grooves formed in the confronting surfaces of the chips 103 and 104. In this particular embodiment, the waveguides 105 terminate at the transverse region 110 of the waveguide holding member 101.

Likewise, the second waveguide holding member 102 is made up of a top chip 106 and a bottom chip 107 which are optionally made of silicon or a silicon containing material. Sandwiched between the top chip 106 and the bottom chip 107 are a plurality of optical waveguides 108 (e.g., optical

fibers). Optionally, the optical waveguides **108** are contained within cavities defined by opposing grooves formed in the confronting surfaces of the chips **106** and **107**. In this particular embodiment, the waveguides **106** terminate at the transverse region **111** of the waveguide holding member **102**.

A guide mechanism is additionally provided to move the waveguide holding member **101** in a transverse direction relative to the waveguide holding member **102**. Here, the transverse direction is perpendicular to the plane of the diagram of FIG. 1. In this illustrative embodiment, the guide mechanism is formed by the combination of recess-defined cavities and guide balls (or ball bearings). In particular, referring to FIG. 1, opposing recesses **112** and **113** are defined in the transverse regions **110** and **111** of the first and second waveguide holding members **101** and **102**, respectively. The opposing recesses **112** and **113** define a cavity **114** for containing a guide ball **115** (e.g., a ball lens). As shown, the recesses **112** and **113** may optionally have a V-shaped cross-section. The diameter of each guide ball **115** is sufficient so as to minimize frictional contact between the opposing transverse surfaces **110** and **111** of the first and second waveguide holding members **101** and **102**, respectively. The guide balls **115** may be formed of ceramics, metals or other hard materials. For example, the guide balls **115** may be formed of quartz, silicon nitride or zirconium. The cavity **114** extends lengthwise in the transverse direction such the guide ball **115** functions to guide the waveguide holding member **101** in a transverse direction relative to the waveguide holding member **102**.

The waveguide holding members **101** and **102**, and particularly the recesses **112** and **113**, may optionally be coated with a wear-resistant material (e.g., CVD silicon nitride).

Reference is now made to FIG. 2 which shows a top view of the optical switch shown in FIG. 1. As illustrated by the double-headed arrow, the transverse direction is parallel to the plane of the diagram of FIG. 2.

In FIG. 2, reference numerals **201** and **202** denote the first and second waveguide holding members, respectively. As shown, a plurality of optical waveguides **205** extend within the first waveguide holding member **201** and terminate at the transverse region **210**. Likewise, another plurality of optical waveguides **208** extend within the second waveguide holding member **202** and terminate at the transverse region **211**. Also, the guide balls **215** are contained within cavities **214** and interposed between the transverse regions **210** and **211**.

As should be readily apparent, the rolling action of the guide balls **215** within the cavities **114** allows for transverse movement of the first waveguide holding member **101** relative to the second waveguide holding member **102**. In this manner, the ends of the optical fibers **205** may be selectively aligned with (and therefore optically coupled with) the ends of the optical fibers **208**. An optical switch is thereby realized.

Motion of the first waveguide holding member **101** relative to the second waveguide holding member **102** may be through use of any number of known actuators, including, but not limited to, electromagnetic, piezoelectric, microelectro-mechanical (MEM), and hydraulic devices. Also, either one of the first and second waveguide holding members **101** and **102** may be secured in a fixed position, while movement of the other is actuated.

Other configurations for achieving transverse movement of the first waveguide holding member relative to the second waveguide holding member may be adopted, such as those described in the previously mentioned commonly assigned

U.S. patent application. Further, the guide balls for guiding the first waveguide holding member relative to the second waveguide holding member may be replaced with other suitable components. For example, transverse cylinders may be provided which function as guide rails. In this case, the waveguide holding members slide along the guide cylinders, as opposed to rolling on the guide balls. The cylinders can be formed, for example, of precision-drawn glass fibers.

FIG. 3 illustrates a modification of the embodiment of FIGS. 1 and 2 in which the ends of the optical waveguides **305** and **308** are terminated with ball lenses **316** and/or GRIN lenses **317**. These lenses **316** and **317** help reduce the mechanical alignment tolerances needed for optical coupling, and can be disposed in grooves or square etched pits, as is known in the art of micro-optical bench devices.

FIGS. 4-7 illustrate another embodiment of the present invention in which a variable attenuator is realized. Referring first to FIG. 4, the device includes a first waveguide holding member **401** and a second waveguide holding member **402**, which move in a transverse direction (double-headed arrow) by action of the cavities **414** and guide balls **415** in the same manner as described above in connection with FIGS. 1 and 2.

In this illustrative embodiment, the first waveguide holding member **401** contains an optical waveguide **405** having an end that terminates at the transverse region **410**. On the other hand, the second waveguide holding member **402** contains a plurality of optical waveguides **408** having ends which terminate at respectively different distances from the transverse region **411**. In other words, the endfaces of the optical waveguides **408** have different longitudinal positions as shown in FIG. 4.

As should be readily apparent, a variable optical attenuator is realized by the transverse movement of the first waveguide holding member **401** relative to the second waveguide holding member **402**. FIG. 5 illustrates a "low attenuation" switch position in which the optical waveguide **505** is aligned with the optical waveguide **508a** having an end closest to the transverse region **511**. In contrast, FIG. 6 illustrates a "high attenuation" switch position in which the optical waveguide **605** is aligned with the optical waveguide **608c** having an end closest to the transverse region **611**. Since the aligned endfaces of FIG. 6 are spaced further apart than in FIG. 5, increased attenuation is achieved.

Referring to FIG. 7, the relative spacing steps D between the endfaces of the optical waveguide **705** and each of the optical waveguides **708** depend on the attenuation values desired. For large steps in attenuation, relatively large spacing steps would be needed. Conversely, small steps in attenuation would require relatively small spacing steps. Optionally, the longitudinal spacing between the waveguide endfaces can be on the order of 0.5, 1, 2, 4, 5, 8, 10 or so microns. Also, the spacing between adjacent optical waveguides need not be constant. Rather, since attenuation is a nonlinear function of endface separation, a non-constant spacing between adjacent optical waveguides may be needed to obtain constant steps in attenuation. Further, although not shown, the ends of the waveguides of FIGS. 4-7 may also include the ball lenses and/or GRIN lenses as illustrated in FIG. 3.

Precision placement of the ends of the optical waveguides **708** of FIG. 7 may be achieved by use of a micro-machined tool as a fiber stop as illustrated in FIGS. 8-10. Referring first to FIG. 8, a plurality of optical waveguides (e.g., fibers) are placed within the cavities or grooves of a waveguide holding member **802**. Also, a micro-machined tool **818**

having pedestals **819** is provided. The height of the pedestals determines the longitudinal spacing of the optical waveguides from the transverse region **811** of the waveguide holding member **802**.

Then, as shown in FIG. **9**, the pedestals **919** of the tool **918** are inserted into the respective cavities or grooves of the waveguide holding member **902** so as to displace the ends of the optical waveguides **908**. Alternately, the tool **918** can be position prior to insertion of the optical waveguides **908**, in which case the ends of the optical waveguides **908** are abutted against the already positioned pedestals **919**. Upon extraction of the tool **1018** as shown in FIG. **10**, the ends of the optical waveguides **1008** are precisely spaced at different distances from the transverse region **1011** of the waveguide holding member **1002**.

FIG. **11** illustrates a variation in which the guide balls **1115** are in first placed in the recesses **1114** such that the micro-machined tool **1118** is pressed against the guide balls **1115**. This assures that the waveguide endfaces are aligned with respect to the front face **1120** of the recesses **1114**, which may provide greater accuracy as compared to the saw-cut or polished transverse surface **1111** of the waveguide holding member **1102**.

FIG. **12** illustrates another variation in which the micro-machined tool has pedestals of equal height that are used to locate the endfaces of the waveguides **1208** at the same, countersunk longitudinal positions.

The pedestals of the micro-machined tool described above are preferably small enough to fit inside the grooves or cavities of the waveguide holding member which contain the optical waveguides. Also, the pedestals and/or the waveguides may be coated with a protective coating (e.g., a polymer coating) to prevent scratching of the waveguide endfaces by the pedestals. The micro-machined tool can be made of silicon or similar materials, such as silicon dioxide, and can be fabricated by a DRIE process.

FIG. **13** illustrates another embodiment of a variable optical attenuator according to the present invention. This configuration is similar to that described in the aforementioned application Ser. No. 09/835,906, with the primary exceptions being that one of the waveguide holding members is optionally fixed in place (non-movable) and a drive mechanism is provided to move the other of the waveguide holding members in a longitudinal direction.

In particular, referring to FIG. **13**, first and second waveguide holding members **1301** and **1302** are placed on the surface of a base substrate **1300**. Movement of the second waveguide holding member **1302** is constrained by the provisions of ball lenses **1315** in cavities defined by opposing etched pits in the confronting surfaces of the member **1302** and the substrate **1300**. This second waveguide holding member **1302** contains a plurality of optical waveguides **1308** with terminate at the transverse regions denoted by reference number **1311**.

In contrast, the first waveguide holding member **1301** is moveable in the longitudinal direction (doubled-headed arrow) by the provision of guide balls **1315** in the elongate cavities defined by opposing elongate recesses **1314** formed in the confronting surfaces of the member **1301** and the substrate **1300**. That is, the waveguide holding member **1302** is movable by the rolling action of the guide balls **1315**, which in turn allows for variable spacing of the gap **G** between opposing transverse regions of the first and second waveguide holding members **1301** and **1302**. In this manner, a variable optical attenuator is realized.

FIG. **14** is a side-view of the variable optical attenuator shown in FIG. **13**. As shown, the lower surface of each of the

first and second waveguide holding members **1401** and **1402** includes a plurality of "pits" **1425** for partially containing the guide balls **1415**. Likewise, the surface of the substrate **1400** contain pits **1425** opposite to the pits **1425** of the lower surface of the second waveguide holding member **1402**. The pits **1425** are sized so as to prevent a rolling action of the guide balls **1415**, and accordingly, movement of the second waveguide holding member **1402** is constrained.

On the other hand, the surface of the substrate **1400** which is opposite the pits **1425** of the first waveguide holding member **1401** includes an elongate recess **1414** as shown in FIG. **14**. The rolling action of the guide balls **1415** within the elongate recesses **1414** translates into longitudinal movement of the first waveguide holding member **1401** relative to the second waveguide holding member **1402**. The gap spacing **G** is thereby varied, which in turn results in variable optical attenuation.

Motion of the movable first waveguide holding member **1401** can be achieved by any suitable drive mechanism **D**, including piezoelectric actuators. Further, the gap spacing **G** can be vary, for example, in a range between 0 and 40 microns, thus providing a wide range of attenuation values. Also, ball lenses and/or GRIN lenses can be provided at the ends of the optical waveguides to collimate the light in the gap **G**. However, collimation lenses may tend to increase the gap spacing needed for a given attenuation value.

As shown in FIG. **15**, in an alternative embodiment a metal spring **1530** is used to apply a downward force **F** as shown on the movable first waveguide holding member **1501**. This helps maintain the member **1501** within the recesses **1514**. A spring attachment **1531** may be fixed (e.g., by glue) to either the base substrate **1500** or the stationary second waveguide holding member **1502**.

Another embodiment of the present invention will now be described with reference to FIGS. **16-18**. As described previously, for example, in connection with FIG. **1**, the optical waveguides may be sandwiched between opposing surfaces of two chips to thereby define a waveguide holding member. However, the waveguide holding member can be formed of a single grooved chip in which the waveguides thereof remain exposed and are not covered by the grooves of an opposing chip.

In particular, referring to FIG. **16**, an optical fiber **1630** is placed in the groove **1631** of a chip **1632** as shown. A diameter of the optical fiber **1630** relative to a cross-dimension of the groove **1631** is such that the optical fiber **1630** protrudes above the surface of the waveguide holding member **1632** along a length of the groove **1631**. Optionally, the groove has a V-shaped cross-section. Next, as shown in FIG. **17**, the fiber **1730** is pressed into the groove **1731** using a lid **1733** and glued in place. The lid **1733** may optionally be made of silicon or silica, and preferably includes a non-stick coating **1734** to avoid sticking of the glue. The coating **1734** is preferably elastomeric, and may be teflon or polyimide. The glue is cured and the lid removed to obtain the configuration of FIG. **18** in which the optical fiber **1830** is fixed within the groove **1831** and exposed to define an open face waveguide holding member **1832**. Such an open faced member can be used, for example, in the fabrication of a variable optical attenuator of FIGS. **13-15**.

Still further embodiments of the present invention will now be described with reference to FIGS. **19-27**. Each of these embodiments is at least partially characterized by the provision of a lenslet array in place of one of the waveguide holding members.

Referring first to FIG. **19**, reference number **1902** denotes a waveguide holding member which is similar in structure to

the second waveguide holding member **102** described above in connection with FIGS. **1** and **2**. As such, the waveguide holding member **1902** includes a plurality of optical waveguides **1908** that extend within the waveguide holding member **1902** and terminate at the transverse region **1911**. Also, recesses are formed within the transverse region **1911** for the purpose of containing guide balls **1915**.

The optical waveguides **1908** of the waveguide holding member **1902** are optically combined with a lenslet array **1940** of a lenslet array holding member **1941**. The transverse surface **1942** of the lenslet array holding member **1941** includes a plurality of pits **1943** which are aligned with and partially contain the guide balls **1915**. In this manner, the lenslet array holding member **1941** is movable in the transverse direction (doubled-headed arrow) relative to the waveguide holding member **1902**.

In the configuration of FIG. **19**, the lenslet array **1940** faces away from the waveguide holding member **1902**. However, as shown in FIG. **20**, the lenslet array **2040** may instead face towards the waveguide holding member **2002**.

Also, in the configuration of FIGS. **19** and **20**, the transverse region of the waveguide holding member contains elongate recesses which allow for transverse movement of the lenslet array holding member as a result of a rolling action of the guide balls. However, in cases where relative transverse movement is not needed or desired, the elongate recess can be replaced with smaller dimension pits **2144** as shown in FIG. **21**. Here, the pits **2144** are aligned with the corresponding pits **2143** of the lenslet array holding member **2141**, with the ball lenses **2115** placed therebetween as shown.

FIG. **22** is a perspective view of a lower chip of the waveguide holding member of FIG. **21**. As shown, one-half of a pit **2244** is wet-etched in a transverse region **2211** of the lower chip **2207** having grooves **2248** on a surface thereof. Then, as shown in FIG. **23**, as similarly configured upper chip **2306** is placed on the lower chip **2307** to define the pits **2344** and the cavities for containing the optical fibers **2308**.

In the cases where transverse movement of the lenslet array holding member is to be avoided, the ball lenses (or guide balls) of the previous embodiments need not be provided. For example, as shown in FIG. **24**, the transverse region **2442** of the lenslet array holding member **2441** may instead be formed with protrusions **2460** for alignment with the corresponding pits **2444** of the waveguide holding member **2402**. In this case, the lenslet array **2440** can be disposed in a wet-etched recess defined between the protrusions **2460**. Optionally, the lenslet array holding member **2441** can be made of silicon, and the protrusions **2460** are defined by the <111> silicon plane. Also optionally, the lenslet array holding member **2441** can be made from an SOI (silicon-on-insulator) wafer, in which case the protrusions are determined by the device layer thickness and the lenslets are disposed on the insulating layer of the SOI wafer.

FIG. **25** illustrates an alternative embodiment in which the alignment protrusions of FIG. **24** are replaced with relative large "lenslets" **2565**. In this case, the alignment lenslets **2565** can advantageously be formed during the same process used to fabricate the lenslet array **2540**.

FIGS. **26** illustrates yet another alternative embodiment in which the lenslet array **2640** can be pivoted about the lens ball **2615**. In the case where pivoting is not desired, the jigs **2770** of FIG. **27** can be used to hold the lenslet array **2740** while it is glued in place.

While the invention has been described in detail with respect to a number of exemplary embodiments, it is clear

that various modifications of the invention will become apparent to those having ordinary skill in art having had benefit of the present disclosure. Such modifications and variations are included in the scope of the appended claims.

What is claimed is:

1. An optical switch comprising:

a first waveguide holding member comprising a first transverse surface region and a first optical waveguide having an end terminating at the first transverse surface region;

a second waveguide holding member comprising a second transverse surface region which confronts the first transverse surface region of the first waveguide holding member and a second optical waveguide having an end terminating at the second transverse surface region; and a guide member which is operatively coupled to the first and second waveguide holding members and which guides the first waveguide holding member in a transverse direction relative to the second waveguide holding member so as to selectively optically couple and decouple the ends of the first and second optical waveguides,

wherein the guide member comprises (a) a plurality of first recesses formed in the first transverse surface region of the first waveguide holding member, (b) a plurality of second recesses formed in the second transverse surface region of the second waveguide holding member and confronting the plurality of first recesses to define a respective plurality of cavities therebetween, and (c) a plurality of guide balls contained with the plurality of cavities, respectively.

2. An optical switch comprising:

a first waveguide holding member comprising a first transverse surface region and a first optical waveguide; a first lens optically coupled to an end of the first optical waveguide and located at the first transverse surface region of the first waveguide holding member;

a second waveguide holding member comprising a second transverse surface region which confronts the first transverse surface region of the first waveguide holding member and a second optical waveguide;

a second lens optically coupled to an end of the second optical waveguide and located at the second transverse surface region of the second waveguide holding member; and

a guide member which is operatively coupled to the first and second waveguide holding members and which guides the first waveguide holding member to move relative to the second waveguide holding member in a direction transverse to the optical axis of the second optical waveguide so as to selectively optically couple and decouple the first and second lenses.

3. The optical switch as claimed in claim 2, wherein at least one of the first and second lenses is a ball lens.

4. The optical switch as claimed in claim 2, wherein at least one of the first and second lenses is a GRIN lens.

5. A method for fabricating an optical switch, comprising the steps of:

providing a first waveguide holding member including a first transverse surface region and a first optical waveguide having an end terminating at the first transverse surface region;

providing a second waveguide holding member including a second transverse surface region and a second optical waveguide having an end terminating at the second transverse surface region;

11

placing the second waveguide holding member proximate the first waveguide holding member so that the second transverse surface region confronts the first transverse surface region of the first waveguide holding member; and
5
providing a guide member which is operatively coupled to the first and second waveguide holding members and which guides the first waveguide holding member in a transverse direction relative to the second waveguide holding member so as to selectively optically couple
10
and decouple the ends of the first and second optical

12

waveguides, the guide member comprising (a) a plurality of first recesses formed in the first transverse surface region of the first waveguide holding member, (b) a plurality of second recesses formed in the second transverse surface region of the second waveguide holding member and confronting the plurality of first recesses to define a respective plurality of cavities therebetween, and (c) a plurality of guide balls contained with the plurality of cavities, respectively.

* * * * *