

1 593 881

(21) Application No. 19249/77 (22) Filed 7 May 1977 (19)

(23) Complete Specification filed 8 May 1978

(44) Complete Specification published 22 July 1981

(51) INT. CL.<sup>3</sup> A4C 13/00

(52) Index at acceptance  
A4M 1A

(72) Inventor WILLIAM JOHNSON FAIRLY



(54) DUAL PURPOSE ARTICLE OF FURNITURE

(71) We, MIDAS UPHOLSTERY LIMITED, of 10 Union Street, North Shields, Tyne and Wear; a British Company, do hereby declare the invention, for which we pray that a patent may be granted to us, and the method by which it is to be performed, to be particularly described in and by the following statement:—

This invention relates to a chair-bed.  
An object of the invention is to provide a seat which is readily convertible for use as sleeping accommodation without requiring an articulated supportive framework.

According to the invention a chair-bed comprises a dual purpose article of furniture comprising a plurality of cushions each formed with a bight, which can be set up together standing on their edges to define a chair, and can be laid flat to form a geometric shape surrounding a space, one or more further cushions being provided to fill the space, and act as respective arm-rests in the chair configuration.

The first mentioned cushions, of which there are usually four, may be L shaped, the longer arm of the L corresponding in inside length to that of one side of each further arm-rest cushion, the length of the other side of which corresponds to twice the inside length of the shorter arm of the L.

The L shaped cushions may be rectilinear or substantially rectilinear and the arm-rest cushions correspondingly quadrilateral, e.g. with a pair of mutually inclined opposed edge faces the other pair being substantially parallel, or substantially rectangular, for fitting within the L shaped cushions disposed therearound for use as a mattress, or bed without articulated supporting framework.

Flexible connectors may be provided at adjacent edges of the cushion, for example fabric hinges incorporated in upholstery between adjacent front edges of alternate superposed cushions and the upper backrest edges of alternating pairs thereof.

All the cushions may be accommodated side by side in a U shaped support.

A preferred embodiment of chair-bed according to the invention will now be described by way of example with reference

to the accompanying drawings, wherein:—

Fig. 1 is a perspective view of the chair-bed made up as a chair;

Fig. 2 shows the cushions unfolded, and Fig. 3 shows the chair-bed made up as a bed.

In the specific embodiment four rectangular L shaped cushions 10, 11, 12 and 13 of resilient foamed material are encased with fabric upholstery incorporating three hinges 14, 15 and in permitting alternatively either side by side juxtaposition of the cushions 10 to 13 as in Fig. 1 or their being laid out flat in rectangular formation with a rectangular hole in the middle as in Fig. 3. Rectangular arm-rest cushions 17 and 18 of similar thickness e.g. 6 inches, are also provided together with a U shaped support frame 19 of tubular steel for holding the six thicknesses when juxtaposed.

The arm-rest cushions 17 and 18 fit in the hole as in Fig. 3 when the cushions are laid out flat.

For providing a settee or chair broader—or narrower—than two feet the thickness of cushions may be varied and the length of the support varied accordingly.

A support base may be manufactured usually separately or at least detachable from, the chair support; it may be upholstered, e.g. for matching the chair cushion fabric or alternatively present the finish of the material in which it is produced, for example plastics and/or wire, glass fibre or resin reinforcement or timber and may have a peripheral rim corresponding to the finished bed size.

This may be varied by appropriate alteration to the dimensions of the cushions e.g. for furnishing a bed more or less compact measuring 1.4 × 2 metres, as indicated in the accompanying drawings.

WHAT WE CLAIM IS:—

1. A dual purpose article of furniture comprising a plurality of cushions each formed with a bight, which can be set up together standing on their edges to define a chair, and can be laid flat to form a geometric shape surrounding a space, one or 100

more further cushions being provided to fill the space, and act as respective arm-rests in the chair configuration.

5 2. An article of furniture according to Claim 1, wherein said first-mentioned cushions are L shaped, four in number and have one leg of the L shape longer than the other, the inside edge of the longer leg serving as a seat and the inside edge of the shorter leg as a back rest, when the cushions are in the chair configuration.

10 3. An article of furniture according to Claim 2 wherein a first cushion forming an outer one of said L shaped cushions as set up to form a chair is connected by a hinge along an edge of the cushion at the extremity of a limb of the L shape, to the corresponding edge of the next inward cushion, which cushion is similarly connected

by a hinge along its edge at the extremity of the other limb of the L shape to the corresponding edge of the next inward cushion, each cushion being thus flexibly connected to the adjustable cushion or cushions. 20

4. An article of furniture according to any preceding claim wherein all said cushions are held in a U shaped frame when assembled in the chair configuration. 25

5. A dual purpose article of furniture substantially as hereinbefore described with reference to and shown in the accompanying drawings. 30

W. REID SHARPE & CO.,  
Chartered Patent Agents,  
10 Portland Terrace,  
Newcastle upon Tyne,  
NE2 1QZ.

1593881

COMPLETE SPECIFICATION

1 SHEET

This drawing is a reproduction of the Original on a reduced scale

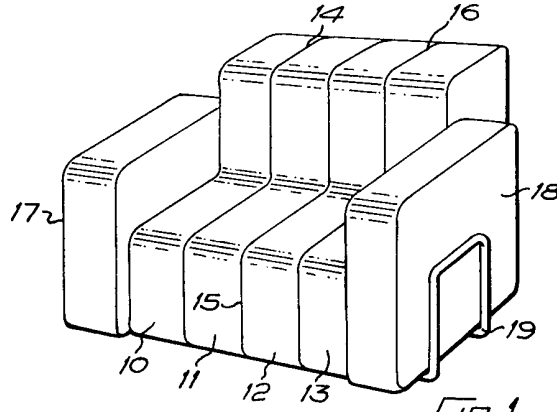

FIG. 1

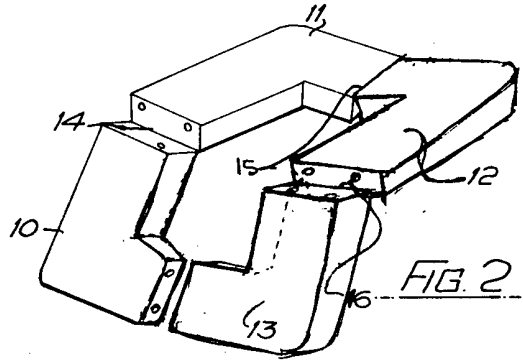

FIG. 2

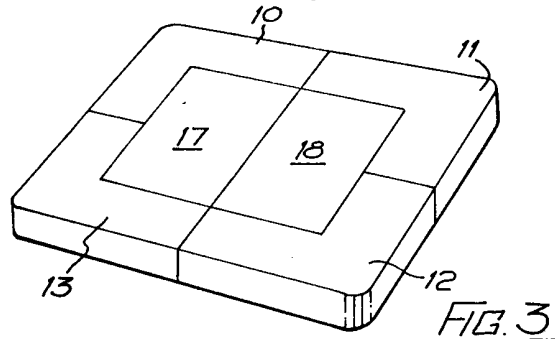

FIG. 3