

(19)
(12)

(KR)
(A)

(51) 。 Int. Cl. ⁷
E01B 9/38

(11)
(43)

2002 - 0033337
2002 05 06

(21) 10 - 2000 - 0064079
(22) 2000 10 30

(71)

972 - 5

(72)

31 - 49

102

(74)

:

(54)

가 가 ,

가 ;

;

3

1 2

3

4a 4c

5a 5c

6a 6c

7a 7b

8a 8b

9a 9b

10a 10c

11a 11c

12

13a

13b

*

1: 2:

10: 11:

12: 13:

14: 15:

31: 32:

41: 43:

44: 45:

46: 1 47:

51: 52:

53: 2 54:

60: 61:

62: 63:

가 가 , , 가 가
가 가 , 가
가 , 가

(concrete ascon) 가 .

가 가 ,

가

(2) (2) (1) (1 1 2) (1) (2)

3 4 (10) (11) (12) (11) (10) (11) (13) (11) (1) (14) (10) (15) (11)

(21) (11) 4a 4c (21) (22) (22) (24) (51) (23) 가 (21) 1:40 (25)

(24) (23)

(12) " □ " (11) (31) (31) (32)

(24) (31) 5a 5c (31b)가 (11) (31a)

(31) (61) (25 ton/cm, 10 ton/cm) (31) (0.5mm 100 ()

(31)가 (11) (10) (11) 2 3mm(5mm) (61) (31) (11)

(11) " □ " (1) (14) 6a 6c
 (42a) 가 (42)가 (31) (41) , (41)
 (42a) (1) (43) , (43) (1)
 (43) (44) (45) ,
 (41) (42a) (43) (47)가
 1 (46) .
 1 (11) (31) , (31) (41)
 (46) (1)
 (11) (21) (10) (13)
 .
 (13) (11) (23) " L " (51) ,
 " ㄱ " (52a) (10) (11)
 (52b)가 (52) , (52) (52a) (51)
 2 (53) , 2 (53) (52) (54) .
 , 가 (51) 7a 7b (11) (23)
 (23) (52) 8a 8b
 (10) (10) (52c) , (52a)
 (10) (52d) (52c) (52d) (51)
 , (10) (52c) (10) (52d) (10)
 , (52) (52d) (52c)
 , 1mm , (52)
 (52) (62) 가 가
 .
 (60)가 (13) (10) (52) (11)
 (63) (52)
 (15)
 , (41) (31) (11)

(1) (10) (61) , (10) (11) (11) (10) (11) (10) (11) (25) (63)

(63) (32) (10) (11)

(1) (61) 9a 9b (P.P) (41) (42a) (61a) 1 (46) (43)

(62) 10a 10b (10) (62a) (62b) (62b) (62c)

(63) 11a 11c (10) (11) (11) (63a)가 (61) (11) (63) (63b) 가

n/cm, 5ton/cm, 6ton/cm, 7ton/cm 4 , (63) 가 10ton/cm 가 4to /cm, 8ton/cm 3 6ton/cm, 7ton

(10) (11) (21) (52) (51) 2 (53) (11) (11) (21) (53) (54) (62) (13) (1)

(15) (12) (15) (11) (11) (10) (11) (62)가 (11) (24) (31) " □ " (15) (12) (61) (1) ,

(52) (62) (10) 10 15% 가 , (10) 가

(10) , (10) (10)

(11) (63) 80%
가 가

(31) (11) 가

12 13 가 (10)

12 (10) , 13a (62)
13b (63)

가 , 가 가

가 가

가 가

(50ton/cm) (4 10ton/cm)

, 가 가 , 가 , , 가 , , 가 가 .

(57)

1.

, 가 ; ; ;

2.

1 ,

, 가 ,

3.

2 ,

1:40 .

4.

2 ,

가 .

5.

1 ,

;

6.

5 ,

7.

5 .

가

8.

1 .

가 ;

;

9.

8 ,

10.

1 4 .

;

, ; ,

2 ;

2

11.

10 .

가 .

12.

10 .

13.

12 ,

14.

10 ,

가 .

15.

1 .

;

;

16.

15

17.

15

18.

15

가

19.

15

18

20.

15

18

가 4ton/cm 10ton/cm

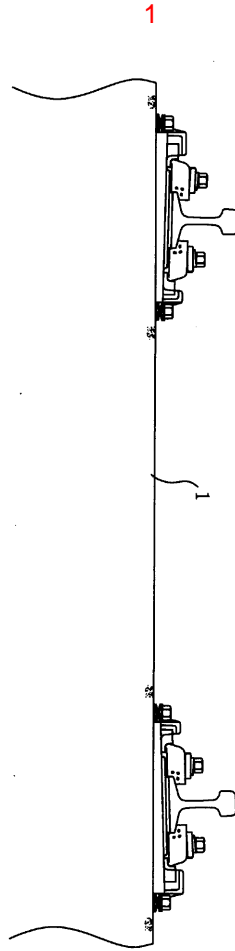

2

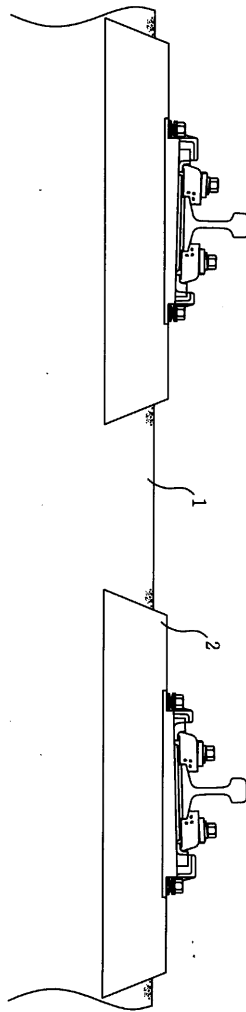

3

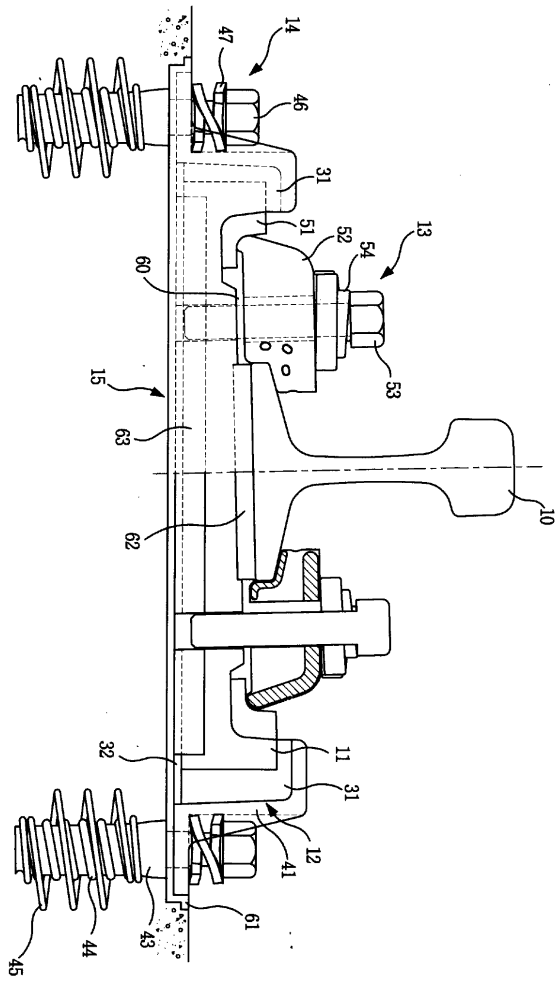

4a

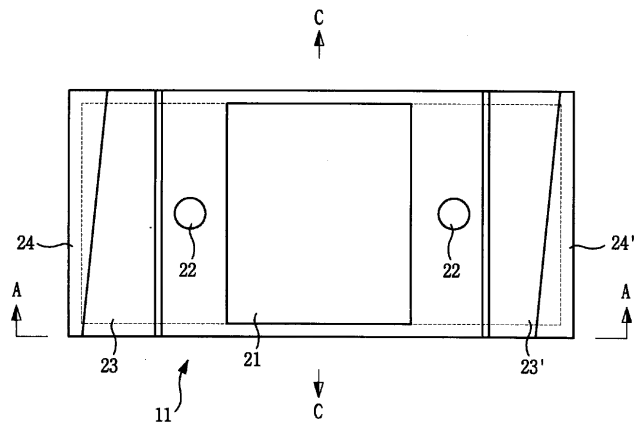

4b

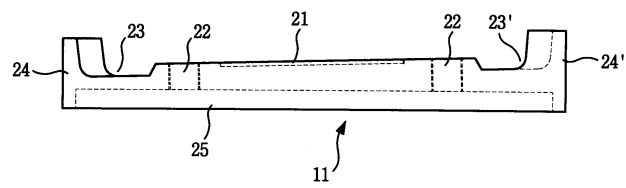

4c

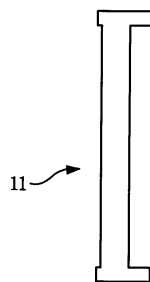

5a

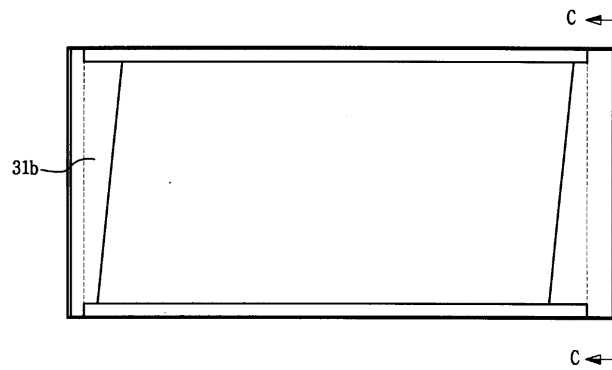

5b

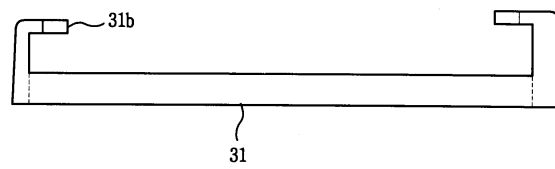

5c

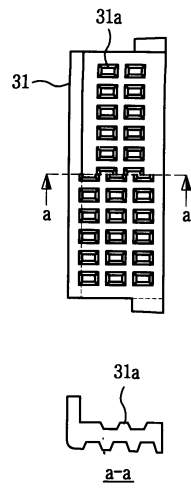

6a

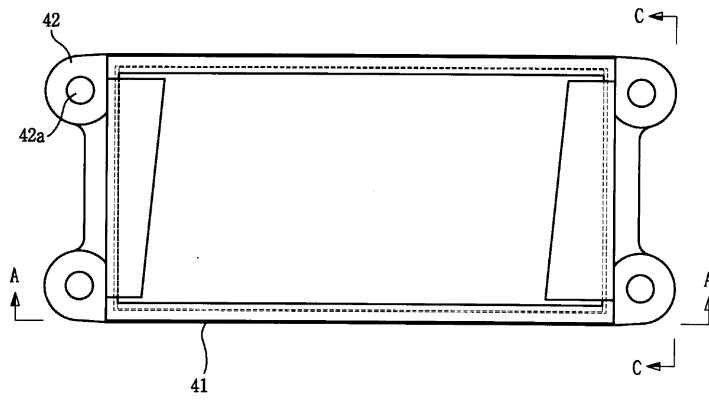

6b

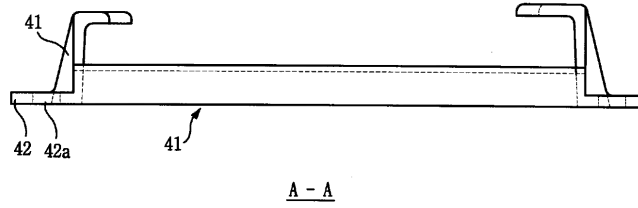

6c

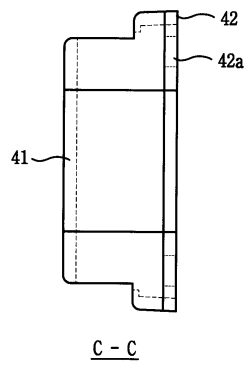

7a

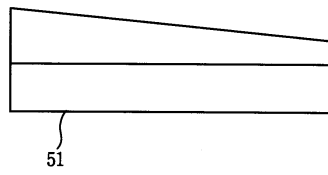

7b



8a

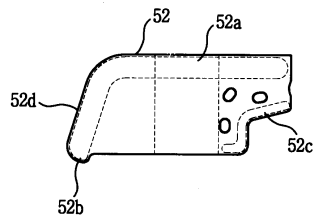

8b

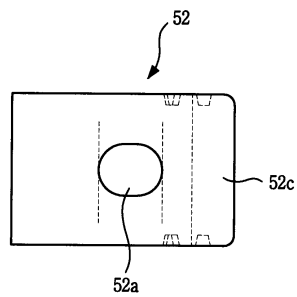

9a

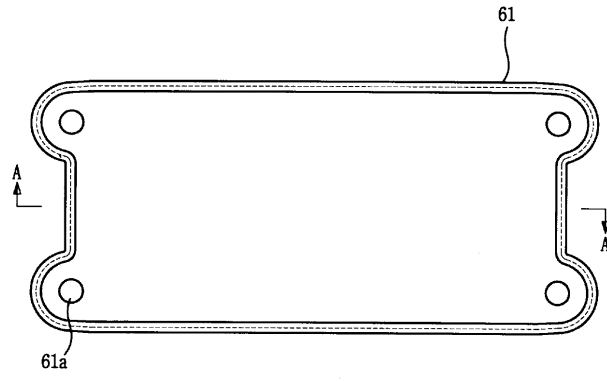

9b

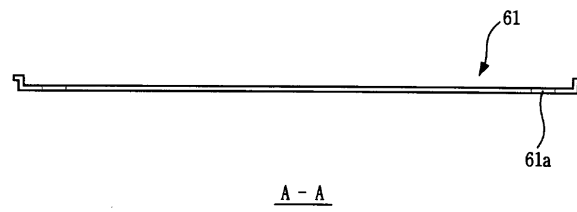

10a

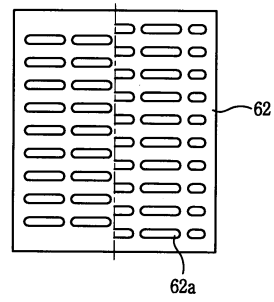

10b

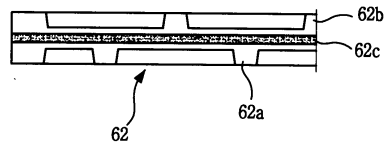

11a

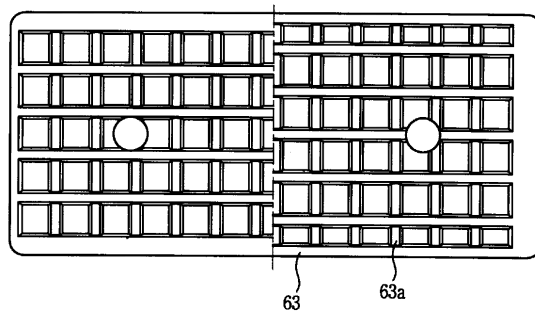

11b

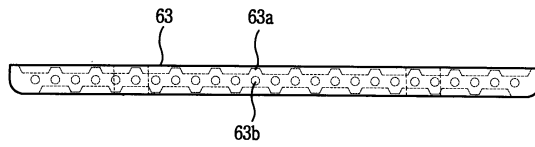

11c

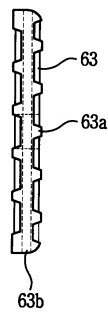

12

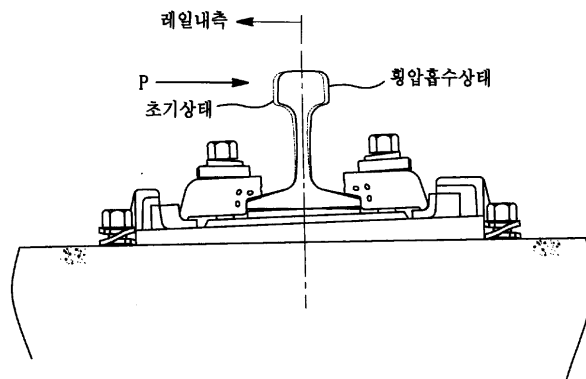

13a

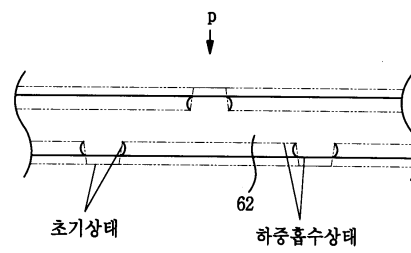

13b

