

A. S. WHITE.
 Harrow and Cultivator.

No. 82,573.

Patented Sept. 29, 1868.

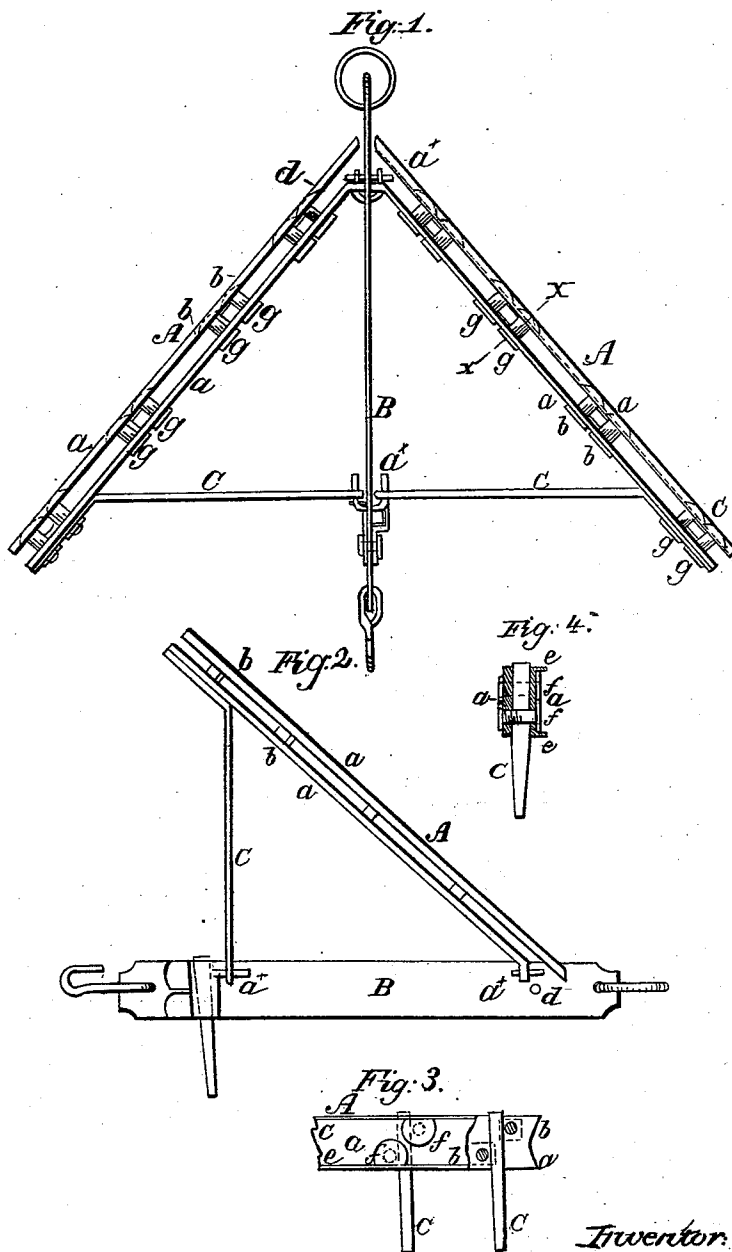

Witnesses:
H. B. Ashkettle
John A. Morgan

Inventor:
A. S. White
 per *Wm. M. Muffey*
 Attorneys

United States Patent Office.

A. S. WHITE, OF MALONE, NEW YORK.

Letters Patent No. 82,573, dated September 29, 1868.

IMPROVEMENT IN HARROW AND CULTIVATOR.

The Schedule referred to in these Letters Patent and making part of the same.

TO ALL WHOM IT MAY CONCERN:

Be it known that I, A. S. WHITE, of Malone, in the county of Franklin, and State of New York, have invented a new and improved Harrow and Cultivator; and I do hereby declare that the following is a full, clear, and exact description thereof, which will enable others skilled in the art to make and use the same, reference being had to the accompanying drawings, forming part of this specification.

This invention relates to a new and improved drag or harrow, which may also be used as a cultivator; and it consists in a novel construction of the same, as hereinafter fully shown and described, whereby the teeth or shares are firmly retained in position, readily detached and replaced, and the implement rendered capable of being constructed in a strong and durable manner, at a moderate cost.

In the accompanying sheet of drawings—

Figure 1 is a plan or top view of my invention.

Figure 2, a side view of the same, with one of its sides turned up in a vertical position.

Figure 3, a side view of a portion of the same, partly in section.

Figure 4, a section of the same, taken in the line *z z*, fig. 1.

Similar letters of reference indicate corresponding parts.

A A represent the two sides of the harrow or cultivator, each of which is composed of two parallel bars, of wood or plates of metal, *a a*, connected, by bolts *b*, with a single plate, *c*, bolted to the rear end of each inner plate, *a*, and forming an angle of about forty-five degrees therewith, as shown in fig. 1.

These sides A A are connected to a central plate, B, which has two curved bars or hooks, *a'*, passing through it, to form hooks, to pass through holes in the front end of the inner plates, *a*, and through holes in the inner ends of the plates *c*; a pin, *d*, which passes transversely through the front part of B, preventing the sides A A becoming casually detached from B, on account of not admitting of a backward movement of the sides, or a backward movement of bar B, when the sides are in a horizontal position, or at work; and in order to detach and apply the sides, it is necessary that they be placed or turned up in a vertical position, so that the front ends of the inner plates, *a*, will be out of line with pin *d*, as they cannot be fitted on the hooks, or removed therefrom, when in any other position.

C represents the harrow-teeth, which are clamped firmly between the two plates *a a* by the bolts *b*, the latter having such a position that the upper part of the front side of each tooth C will bear against a bolt, and also the rear side of the lower part of each tooth which is between the plates, (see fig. 3.) Each tooth, therefore, is secured between two bolts, and firmly retained in position.

The outer plate, *a*, of each side, A, is provided with a horizontal flange, *e*, at its upper and lower edge, and the heads *f* of the bolts are cut at one part to form a straight edge, to bear against the flanges *e*, and prevent the turning of the bolts, while their nuts *g* are being screwed on and off.

By this arrangement, it will be seen that the teeth may be readily attached to and detached from the harrow, and when detached, be firmly retained in position.

When the device is to be used as a cultivator, shares or teeth, constructed for that purpose, are secured to the implement in the same manner.

The draught-animals are attached to the front end of the plate B. The sides A A are allowed to rise and fall, to accommodate themselves to the inequalities of surface. These sides swing or work freely, and cannot possibly become casually detached in working (rising and falling) within the scope of their working-movement, for the reason previously explained.

The plates *a a*, *c*, and B, may be constructed of wood or metal; the latter material, however, is deemed most desirable.

Having thus described my invention, what I claim as new, and desire to secure by Letters Patent, is—

1. A harrow and cultivator, composed of two sides, A A, constructed each of two parallel plates, *a a*, and a plate, *c*, attached to the rear end of the inner plate of the former at an acute angle, the plates *a a* being con-

ected by bolts *b*, and the teeth or shares clamped between said plates by the bolts, substantially as shown and described.

2. Connecting the sides A A of the harrow and cultivator to the central plate B by means of the curved bars or hooks *a*^x passing through it, which bars or hooks pass through holes in the plates *c*, and the inner plates, *a*, of the sides, substantially as shown and described.

3. The pin *d*, fitted in the central plate B, in combination with the curved bars or hooks *a*^x, arranged substantially as and for the purpose set forth.

A. S. WHITE.

Witnesses:

WM. F. McNAMARA,

ALEX. F. ROBERTS.