

AUSTRALIA

Patents Act 1952

DECLARATION IN SUPPORT OF A CONVENTION APPLICATION FOR A PATENT

In support of the Convention application made for a patent for an invention entitled:

Hand-operated applicator for media
Peter Pfeiffer

of Ing. Erich Pfeiffer GmbH & Co. KG, of Josef-Bosch-Strasse 4, D-7760 Radolfzell, FEDERAL REPUBLIC OF GERMANY do solemnly and sincerely declare as follows:-

1. ~~I am authorized by the applicant~~

(or, in the case of an application by a body corporate)

1. I am authorized by ING. ERICH PFEIFFER GMBH & CO. KG, the applicant for the patent to make this declaration on its behalf. Federal Republic of Germany

2. The basic application as defined by section 141 of the Act was made in Germany on the 8th day of July, 1987, by Ing. Erich Pfeiffer GmbH & Co. KG

3. ~~I am authorized by the applicant~~

(or, where a person other than the inventor is the applicant)

3. Karl-Heinz FUCHS

of 67 Am Graben, Radolfzell D-7760, Federal Republic of Germany

is the actual inventor of the invention and the facts upon which the applicant would, if a patent were granted on an application made by the said actual inventor, be entitled to have the patent assigned to it.

4. The basic application referred to in paragraph 2 of this Declaration was the first application made in a Convention country in respect of the invention the subject of the application.

(or, where a request is made under section 142AA of the Patents Act 1952, for an earlier application made in a Convention country to be disregarded)

4.-(1.) The basic application referred to in paragraph 2 of this Declaration was not the first application made in a Convention country in respect of the invention the subject of the application.

(2.) An earlier application in respect of the invention the subject of the application was made in _____ on _____

(3.) A request has been made to you under section 142AA of the Patents Act 1952 to disregard that earlier application.

(Here set out in succeeding sub-paragraphs the facts that show that section 142AA is applicable)

Except as stated in this paragraph, the basic application referred to in paragraph 2 of this Declaration the first application made in a Convention country in respect of the invention the subject of the application.

Declared at Radolfzell this 5. day of December, 1989

(Signature of Declarant)

Ing. Erich Pfeiffer GmbH & Co. KG
(Peter Pfeiffer) Managing Director

TO: THE COMMISSIONER OF PATENTS.

(IMPORTANT - Cross out inapplicable words in above Form.)

(July 1983)

(12) PATENT ABRIDGMENT (11) Document No. AU-B-20721/88
(19) AUSTRALIAN PATENT OFFICE (10) Acceptance No. 619200

- (54) Title
HAND-OPERATED APPLICATOR FOR MEDIA
- International Patent Classification(s)
(51)⁴ **B05B 011/06 B05B 007/10**
- (21) Application No. : **20721/88** (22) Application Date : **05.07.88**
- (87) PCT Publication Number : **WO89/00086**
- (30) Priority Data
- (31) Number (32) Date (33) Country
3722470 08.07.87 DE FEDERAL REPUBLIC OF GERMANY
- (43) Publication Date : **30.01.89**
- (44) Publication Date of Accepted Application : **23.01.92**
- (71) Applicant(s)
ING. ERICH PFEIFFER GMBH & CO. KG
- (72) Inventor(s)
KARL-HEINZ FUCHS
- (74) Attorney or Agent
DAVIES COLLISON CAVE , 1 Little Collins Street, MELBOURNE VIC 3000
- (56) Prior Art Documents
EP 217744
US 4179049
US 3945574
- (57) Claim

1. A manually operable discharging apparatus comprising a discharge nozzle having at least one discharge opening leading into the open, said discharge nozzle having cooperating first and second distributing nozzles providing first and second nozzle exit openings defined by end portions of first and second nozzle ducts, at least one of said first distributing nozzles providing a rear nozzle exit opening located upstream of a front nozzle exit opening of at least one of said second distributing nozzles, wherein said at least one first distributing nozzle is an atomizing nozzle, thereby providing in at least two steps a first atomization of the medium to an atomized flow and at least one subsequent further atomization of said atomized flow.

PCT

AU-AI-20721/88

WELTORGANISATION FÜR GEISTIGES EIGENTUM
Internationales Büro

619200



INTERNATIONALE ANMELDUNG VERÖFFENTLICHT NACH DEM VERTRAG ÜBER DIE
INTERNATIONALE ZUSAMMENARBEIT AUF DEM GEBIET DES PATENTWESENS (PCT)

<p>(51) Internationale Patentklassifikation⁴ : B05B 11/06, 7/10</p>	<p>A1</p>	<p>(11) Internationale Veröffentlichungsnummer: WO 89/ 00086 (43) Internationales Veröffentlichungsdatum: 12. Januar 1989 (12.01.89)</p>
<p>(21) Internationales Aktenzeichen: PCT/EP88/00598 (22) Internationales Anmeldedatum: 5. Juli 1988 (05.07.88) (31) Prioritätsaktenzeichen: P 37 22 470.0 (32) Prioritätsdatum: 8. Juli 1987 (08.07.87) (33) Prioritätsland: DE (71) Anmelder (für alle Bestimmungsstaaten ausser US): ING. ERICH PFEIFFER GMBH & CO. KG [DE/ DE]; Josef-Bosch-Straße 4, D-7760 Radolfzell (DE). (72) Erfinder; und (75) Erfinder/Anmelder (nur für US) : FUCHS, Karl-Heinz [DE/DE]; Am Graben 67, D-7760 Radolfzell (DE). (74) Anwälte: BEIER, J. usw.; Ruff und Beier, Neckarstraße 50, D-7000 Stuttgart 1 (DE).</p>	<p>(81) Bestimmungsstaaten: AT (europäisches Patent), AU, BE (europäisches Patent), CH (europäisches Patent), DE (europäisches Patent), FR (europäisches Patent), GB (europäisches Patent), IT (europäisches Patent), JP, KR, LU (europäisches Patent), NL (europäisches Patent), SE (europäisches Patent), SU, US. Veröffentlicht Mit internationalem Recherchenbericht.</p> <p style="text-align: right;">A. O. J. P. 23 MAR 1989 AUSTRALIAN 30 JAN 1989 PATENT OFFICE</p>	

(54) Title: HAND-OPERATED APPLICATOR FOR MEDIA

(54) Bezeichnung: HANDBETÄTIGBARE AUSTRAGVORRICHTUNG FÜR MEDIEN

(57) Abstract

In a hand-operated applicator (1), the applicator nozzle (25) has an at least two-stage atomizer (100) in which the medium flow is essentially more finely atomized, for example by the Laval effect, after preliminary atomization due to sudden acceleration by a swivelling current of compressed air. For this purpose, compressed air is fed to the applicator nozzle (25) immediately before the nozzle end orifice (80)) through a separate compressed air channel section (96), from a time immediately before conveying of the medium to a time immediately after conveying of the medium. The compressed air can be produced in a simple fashion by a compressed air pump (50) integral with the medium pump (2) and actuated jointly therewith by a single handle (22). The compressed air pump (50) is located in an extender of the medium pump (2) in the immediate vicinity of its outer end, and its pump cylinder (5) is formed by the cap-shaped handle (22). The compressed air flow can also be directed to other desired points on the applicator (1), for example for cleaning the medium discharge channel (24) as far as the applicator nozzle (25), and incorporated in control functions of valves, in particular discharge valves.

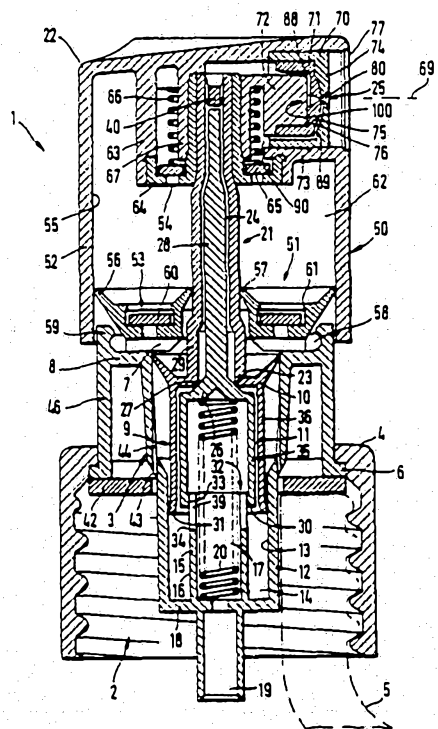

(57) Zusammenfassung Bei einer handbetätigbaren Austragvorrichtung (1) weist die Austragdüse (25) eine mindestens zweistufige Zerstäubereinrichtung (100) auf, in welcher der Medienstrom nach der Vorzerstäubung durch schlagartige Beschleunigung mit einem verwirbelten feinen Druckluftstrom nochmals wesentlich feiner, beispielsweise nach dem Laval-Effekt zerstäubt wird. Zu diesem Zweck wird der Austragdüse (25) unmittelbar vor der Düsenendöffnung (80) über einen gesonderten Druckluft-Kanalabschnitt (89) Druckluft von einem Zeitpunkt unmittelbar vor der Zuführung des Mediums bis zu einem Zeitpunkt nach dessen Zuführung zugeleitet. Die Druckluft kann in einfacher Weise durch eine baulich mit der Medienpumpe (2) vereinte und gemeinsam mit dieser über eine einzige Handhabe (22) betätigbare Druckluftpumpe (50) erzeugt werden, welche in Verlängerung der Medienpumpe (2) unmittelbar benachbart zu deren äußerem Ende vorgesehen und deren Pumpenzylinder (52) durch die kappenförmige Handhabe (22) gebildet ist. Der Druckluftstrom kann auch an andere Bedarfsstellen der Austragvorrichtung (1), beispielsweise zur Reinigung des Medien-Auslaßkanals (24) bis zur Austragdüse (25) geleitet und für Steuerfunktionen von Ventilen, insbesondere von Auslaßventilen, herangezogen werden.

LEDIGLICH ZUR INFORMATION

Code, die zur Identifizierung von PCT-Vertragsstaaten auf den Kopfbögen der Schriften, die internationale Anmeldungen gemäss dem PCT veröffentlichen.

AT Österreich	FR Frankreich	MR Mauritien
AU Australien	GA Gabun	MW Malawi
BB Barbados	GB Vereinigtes Königreich	NL Niederlande
BE Belgien	HU Ungarn	NO Norwegen
BG Bulgarien	IT Italien	RO Rumänien
BJ Benin	JP Japan	SD Sudan
BR Brasilien	KP Demokratische Volksrepublik Korea	SE Schweden
CF Zentrale Afrikanische Republik	KR Republik Korea	SN Senegal
CG Kongo	LI Liechtenstein	SU Soviet Union
CH Schweiz	LK Sri Lanka	TD Tschad
CM Kamerun	LU Luxemburg	TG Togo
DE Deutschland, Bundesrepublik	MC Monaco	US Vereinigte Staaten von Amerika
DK Dänemark	MG Madagaskar	
FI Finnland	ML Mali	

619200

COMMONWEALTH OF AUSTRALIA
PATENTS ACT 1952
COMPLETE SPECIFICATION

**NAME & ADDRESS
OF APPLICANT:**

Ing. Erich Pfeiffer GmbH & Co. KG
Josef-Bosch-Strasse 4
Radolfzell D-7760
Federal Republic of Germany

NAME(S) OF INVENTOR(S):

Karl-Heinz FUCHS

ADDRESS FOR SERVICE:

DAVIES & COLLISON
Patent Attorneys
1 Little Collins Street, Melbourne, 3000.

COMPLETE SPECIFICATION FOR THE INVENTION ENTITLED:

Hand operated applicator for media

The following statement is a full description of this invention, including the best method of performing it known to me/us:-

5

10

15

cccccc
c

20

cc
cc
cc

cc
cc
cc

cccc
cc

cc
cc
cc

25

This invention relates to a manually operable discharging apparatus.

cccccc
cc

cccc
cc

cc
cc
cc

30

It has been previously proposed to use such discharging apparatus to produce a very fine atomization of a medium or of media, particularly liquids, using manual operation to provide the operating energy. However it has not been possible hitherto to provide as fine an atomization of the medium as can, for example, be provided by a discharging apparatus filled with a propellant gas charge.

c

cccc
cc

cc
cc

35

The present invention seeks to provide a manually operable discharging apparatus which permits a much finer atomization than hitherto, particularly an atomization with droplet sizes below 50 to 70 μm .



According to the present invention there is provided a manually operable discharging apparatus comprising a discharge nozzle having at least one discharge opening leading into the open, said discharge nozzle having
5 cooperating first and second distributing nozzles providing first and second nozzle exit openings defined by end portions of first and second nozzle ducts, at least one of said first distributing nozzles providing a
10 rear nozzle exit opening located upstream of a front nozzle exit opening of at least one of said second distributing nozzles, wherein said at least one first distributing nozzle is an atomizing nozzle, thereby providing in at least two steps a first atomization of the medium to an atomized flow and at least one
15 subsequent further atomization of said atomized flow.

As a result the preatomized medium can be subjected to such a high acceleration that its droplets can be broken down into finer droplets under the energies which occur. If, for example, use is made of the Laval effect,
20 an acceleration to supersonic speed is possible thereby permitting an extremely fine atomization or nebulization of the medium.

Compressed air may be conveyed through the discharge nozzle and the medium may be supplied, in its preatomized
25 form, into the compressed air flow by means of a separate pipe in the vicinity of the discharge nozzle soon after the compressed air has commenced to flow. It is also advantageous towards the end of the atomization process to firstly shut off the flow of the medium and then, for
30 example, after the discharge nozzle has been cleaned by the flow of compressed air, the flow of compressed air is shut off.

To assist the atomizing or nebulizing action in one or both nozzle stages, nozzle profiles may be provided,
35 in the form of whirling or swirling means, and in



the discharge direction narrower and/or progressively widening pipe or duct sections may be provided.

In a preferred embodiment there is provided a manually operable compressed
5 air pump, associated with the discharge nozzle, which is connected by means of
a compressed air duct to said discharge nozzle, the compressed air pump and
the medium pump being constructible in such a way that they can be operated
separately with two hands or preferably together with one hand and they can
be constructionally combined. This leads to a very compact and operationally
10 reliable discharging apparatus which, in the case of high discharge energy,
ensures an ultrafine atomization of the medium.

In an alternative construction, it is also conceivable to substantially only
atomize the liquid by a compressed air flow.

15

Embodiments of the present invention will now be further described, by way of
example only, with reference to the accompanying drawings in which:

20

Fig. 1 is an elevational view of a first embodiment of the discharging
apparatus;

Fig. 2 is an axial sectional view of the discharging apparatus of Fig. 1 on a
larger scale;

25

Fig. 3 is a detail of Fig. 2 on a larger scale, but showing a different piston unit
position;

30

Fig. 4 is a detail of Fig. 3 in the vicinity of the discharge nozzle on a still larger
scale;

Fig. 5 is another embodiment in a representation corresponding to Fig. 4;



Fig. 6 is another embodiment in a representation corresponding to that shown in Fig. 4;

Fig. 7 is a further embodiment of a discharge nozzle in axial section;

5

Fig. 8 is a sectional view approximately along the line VIII-VIII of Fig. 7, but without an external nozzle cap;

Fig. 9 is a corresponding sectional view along line IX-IX of Fig. 7;

10

Fig. 10 is an axial sectional view of another embodiment of a discharge nozzle;

Fig. 11 is another embodiment of a discharging apparatus in a representation similar to that shown in Fig. 2;

15

Fig. 12 is another embodiment of a discharging apparatus in a representation corresponding to Fig. 2;

Fig. 13 a detail of another embodiment of a discharging apparatus in axial section; and

20

Fig. 14 is another embodiment in a representation corresponding to Fig. 13.

The discharging apparatus 1 shown in Figs. 1 to 4 has a thrust piston pump 2 having a cylinder casing 3 to be fixed by a cap 4 to the neck of a vessel 5, the vessel 5 constituting a reservoir. The cylinder casing 3 is axially braced against an end face of the vessel neck by an annular flange

25



6 and whilst interposing a gasket 42 and axially outside the annular flange 6 is provided with a cylinder head or cover 7 to be described hereinafter. In the vicinity of said outer end, the cylinder casing 3 passes via a radially downwardly projecting partition 8 into a sleeve surrounding the same and which is provided at the opposite end with the annular flange 6.

A piston unit 9 having two coaxially telescoping working pistons, namely an outer pump piston 10 and a presuction piston 11 located in the same is displaceably mounted in cylinder casing 3. The inner end of cylinder casing 3 projecting into vessel 5 forms a cylinder with a piston running path 13 for two sealing lips on the ends of the pump piston 10. Within the cylinder 12 is provided a presuction cylinder 15 projecting freely against the piston unit 9 from an annular bottom wall 18 and into which issues an inlet passage 19, which projects inwards from bottom wall 18 in the opposite direction. The outer circumference of presuction cylinder 15 forms the piston running path 16 for the presuction piston 11 engaging over it.

The space between the piston running path 13,16 is formed by the pump chamber 14, in which is coaxially located the presuction chamber 17 bounded by presuction cylinder 15 and presuction piston 11 and in which is arranged a restoring spring 20 loading the piston unit 9 towards the starting position.

The outer or rear end of pump piston 10 is provided with a tubular piston shaft located in the axis thereof and guided outwards through the cylinder cover 7 and which bounds an outlet passage 24 connected to pump chamber 14, whilst interposing an outlet valve 23. Outlet passage 24 leads to a discharge nozzle 25 in a handle 22 in the form of an operating head arranged at the outer end of piston shaft 21 and which in each position engages with a small gap over the sleeve of cylinder casing 3.

An end wall of the presuction piston 11 facing the presuction chamber 14 forms a frustum-shaped valve closing part 26 of the outlet valve

23, whose valve seat 27 is provided on an associated end wall of pump piston 10. A shaft 28 for opening outlet valve 23 projects from the presuction piston 11 displaceably into the piston shaft 21. A portion of the piston shaft 21 connected to pump piston 10 forms an elastically resilient, compressible neck 29.

On operating the discharging apparatus by pressing down handle 22, on reaching a predetermined pressure, outlet valve 23 is opened by differential pressure. For filling the pump chamber 14 during the return stroke of the piston unit 9 is provided a pass-over valve 32 which, in displacement-dependent manner, is only open over a final portion of the return travel of the piston unit extending to the starting position, but is closed over most of the pump stroke extending to the pump stroke end position. The closing part 33 of this slide valve is formed by the front piston lip of the presuction piston 11 with which are associated approximately axial valve slots 39 at the free end of presuction cylinder 15 to constitute valve openings. As soon as the presuction piston 11 has reached in the direction of the pump stroke the terminal edges of the valve slots 39 provided as valve closing edges 34, the pass-over valve 32 is closed and correspondingly it is reopened in surge-like manner during the return stroke of the presuction piston 11 and after a vacuum has built up in pump chamber 14. At the end of the pump stroke, the two end faces 30,31 of the pump piston 10 and the presuction piston 11 can strike in time-delayed manner against bottom wall 18 in such a way that the outlet valve 23 is opened, optionally for ventilating the pump chamber 14. The cup-shaped presuction piston 11 has a piston sleeve 35 forming the end face 30 and which approximately extends over the entire length of a piston sleeve 36 of pump piston 10.

The piston shaft 21 has a driver or dog 40 facing with limited spacing the end of shaft 28 and which on shortening the neck 29 runs up after the pump piston 10 has struck shaft 28 in the pump stroke end position and consequently opens the outlet valve 23. The thrust piston pump 2 also has a displacement-dependent, valve-controlled ventilation means for vessel 5. Between the two piston lips of pump piston 10 are provided

in the surface of cylinder casing 3 ventilating through-openings 43, which are immediately adjacent to the outside of the gasket 42 in the vicinity of an annular clearance, which is bounded by gasket 42 and the outer circumference of cylinder casing 3. The passage openings are provided at the end of longitudinal channels 44, which are freed to the outside for producing the ventilation connection at least towards the end of the pump stroke from the rear lip of the pump piston 10. The discharging apparatus 1 can be constructed in accordance with German patent application P 37 15 301.3, particularly with regards to the described parts or assemblies and reference should be made thereto for further details and actions. However, the pump can also be formed by a completely different, manually operable pump type, e.g. a bellows, diaphragm, balloon or similar pump. It is also conceivable to construct the medium pump in such a way that it initially produces a precompressed pressure in vessel 5 and as a result the medium is conveyed via a riser to the outlet passage and to the discharge nozzle 25, as is e.g. described in German patent application P 37 12 327.0.

Apart from the medium pump 2, a preferably manually operable compressed air pump 50 is associated as a compressed air source with the discharging apparatus 1 and is constructionally separate from pump 2 or vessel 5 and can optionally also be constructed as a foot-operable pump and is then appropriately connected by means of a line, such as a flexible hose to the vessel or the part of the discharging apparatus 1 arranged thereon. This compressed air pump can also be formed by different pump types, e.g. those explained with respect to the medium pump. However, in the case of a particularly advantageous embodiment the compressed air pump 50 is constructed as a thrust piston pump, is constructionally combined with the discharging apparatus 1, is operated substantially simultaneously with the same handle 22 as the medium pump 2 and is arranged equiaxially within and/or axially immediately adjacent to the medium pump 2 and appropriately following on to the outer end thereof. Although it is conceivable to connect the compressed air pump 50 to the discharge passage 24 or the discharge nozzle 25, accompanied by the interposing of a pressure tank to be loaded therewith by means of a manually operable

valve, a particularly simple construction is obtained if the compressed air pump 50 is directly connected, so that compressed air is essentially only conveyed during operation.

The compressed air pump 50 has a pump piston 51, a pump cylinder 52 receiving the same, an air inlet valve 53 integrated with the pump piston 51 and an air outlet valve 54 constructionally combined with the pump cylinder 52, which are equiaxial to one another and located in the central axis of the medium pump 2 substantially entirely within the outer boundaries of the cap-like handle 22. Although it is conceivable, much as for the medium pump 2, to move the pump piston by operation with respect to the casing arranged on or fixed to vessel 5, according to a preferred embodiment the pump piston 51 is fixed with respect to said casing or on cylinder casing 3 and pump cylinder 52 is movable with handle 22.

In a very similar construction, without a separate cylinder casing being necessary for the compressed air pump 50, the pump cylinder 52 is directly formed by the cap surface of handle 22 engaging over the sleeve 46 of cylinder casing 3 and whose inner circumference over part of its length forms the piston running path 55 for a radially outer lip 56 of pump piston 51 conically widened in acute-angled manner towards the cap end wall of handle 22. A corresponding, radially inner piston lip 57 of pump piston 51 conically tapered in the same direction runs on the cylindrical outer circumference of a portion of the piston shaft 21 connected to neck 29 and extending approximately to the connection with handle 22.

For fixing purposes, the pump piston 51 has at its end face remote from the piston lips 56,57 an approximately annular snap element 58, which is inserted in an annular clearance on a collar-like shoulder constructed as an inner groove and which as an extension of sleeve 46 projects slightly from the side of partition 8 remote therefrom, so that the pump piston 51 is supported axially against the pump pressure by engaging on partition 8. On said end side of the pump piston 51 is also provided



the cylinder cover 7 in the form of ribs projecting radially into the vicinity of the associated widened section of the cylinder bore of cylinder casing 3 and uniformly distributed about the pump axis, which can be constructed in one piece with cylinder casing 3 or the pump piston 51 made from a relatively soft material, so that in the starting position of pump piston 10, the medium pump 2 with its rear piston lip can strike relatively softly against cylinder cover 7.

It is also conceivable for the cap circumferential surface or pump cylinder 52 to run in sealed manner with respect to sleeve 46 with a sealing lip or the like, so that the casing or the associated part of the cylinder casing 3 can directly form in one piece the pump piston. However, appropriately the gap between the pump cylinder 52 and the casing forms an inlet slot for the ventilation air for vessel 5 and/or for the suction air for compressed air pump 50, which appropriately on and beyond the outer circumference of pump piston 51 between interruptions or breaks in the snap element 50, sucks the suction air through the pump piston 51 from its back surface remote from the piston lips 56,57.

For this purpose in a ring disk-like bottom wall connecting the piston lips 56,57 is provided ring-distributed air passage openings, which can be closed with a ring disk-like valve body 60 made from an elastic material in the manner of a non-pretensioned check valve. Valve body 60 is located on the inside of the bottom wall between piston lips 56,57 and is stop-limited in the opening direction by at least one and in particular two coaxial tori 61, which are provided on the facing circumferential sides of the piston lips 56,57 in spaced manner from the bottom wall, said spacing being only slightly larger than the thickness of valve body 60.

The smaller diameter, but similarly constructed outlet valve 54 operates in the manner of a pretensioned overpressure valve, which only opens on reaching a predetermined overpressure in the pump or pressure chamber 62 and releases the path for the compressed air to the discharge nozzle 25. In a bush 63 projecting inwards from the cap end wall of handle 22 over

most of the circumference with a radial spacing from the cap circumferential surface is inserted a collar sleeve-like insert 64 with a flange-like collar and is so secured by a snap connection that the collar terminates approximately flush with the free end face of bush 63. In the ring disk-like part of the collar of insert 64 passage openings are arranged in a ring and can be closed by a ring disk-like valve body 65. Valve body 65 engages on the end face of the collar of insert 63 remote from the pressure chamber 62 under the tension of a valve spring 66 constructed as a helical compression spring and which is arranged in an annular clearance between a bush 63 and a further plug bush 67 of handle 22 positioned coaxially within the same. In said plug bush 67 is inserted the sleeve portion of insert 64, in which in turn is inserted the associated, smaller outer diameter end of the piston shaft 21 in the manner of a press fit, in such a way that there is a substantially rigid connection between piston shaft 21 and handle 22, the free end faces of piston shaft 21 and the sleeve portion of insert 64 are located flush with one another adjacent to the cap end face of handle 22 and the dog 40 is provided in the associated end region of piston shaft 21.

The discharge nozzle 25 is formed substantially by four bodies approximately coaxial and at right angles to the central axis of the medium pump 2 or the compressed air pump 50, namely nested nozzle caps 70,71, an inner body 72 engaging in the inner nozzle cap 71 and an outer bush 73 receiving on the outer circumference the outer nozzle cap 70 and which can be constructed in one piece with inner body 72 or can be constructed like the latter with the handle and is appropriately connected both to the circumferential surface of bush 63 and to the cap end wall of handle 22. The end walls of the nozzle caps 70,71 essentially at right angles to nozzle axis 69 form nozzle end plates 74,75, which engage on one another in approximately whole-surface manner, the end face 76 of inner body 72 engaging in approximately whole-surface manner on the inner end face of the rear nozzle end plate 75 and the front nozzle end plate 74 is set back with respect to the front end face 77 of outer bush 73 by less than half of its internal diameter corresponding to

the external diameter of the nozzle cap 70. The nozzle end plate 75 is thickened towards the nozzle axis by a convexly projecting construction of its outer end face 78 and engaging in a substantially whole-surface manner in a corresponding concave portion of the inner end face of the nozzle end plate
5 74.

The nozzle end opening 80 leading into the open is approximately located in the outer end face of the nozzle end plate 74 or is slightly set back with respect thereto in the bottom surface of a flat depression 79, so that the nozzle end opening 80 is set back with respect to the front end of outer bush
10 73 and is shielded to the front by the latter. The nozzle passage of the discharge nozzle 25 is essentially formed by two separate individual passages or nozzles 81,82, which are positioned equiaxially directly behind one another.

The front nozzle 81 formed by a corresponding nozzle passage in the nozzle end plate 74 and whose nozzle exit opening is formed by the nozzle end
15 opening 80 has a smaller length than its median or minimum width and is continuously conically widened in acute-angled manner over its entire length from a nozzle inlet opening 83 in the vicinity of the inner end face of nozzle end plate 74 to the nozzle outlet opening.

The rear nozzle 82 formed by a nozzle passage in the nozzle end plate
20 75 compared therewith and compared with its median diameter has a greater length, which is smaller compared with its greatest diameter and is constricted in the flow direction or in the direction of the upstream nozzle 81. A rear longer portion is conically tapered in acute-angled manner from an associated nozzle inlet opening 85 located in the inner end face of the nozzle end plate
25 75 and to its smallest diameter is connected a constant width or diameter portion extending up to associated nozzle outlet opening 84 located in end face 78, so that there is both a continuous and a stepped constriction of said nozzle 82 to a minimum width, which is slightly smaller than the smallest width of nozzle 81.

30 Between the two individual nozzles 81, 82 is provided a whirling device 86 constructed in one piece with at least one of the two nozzle end



plates and in particular the front plate 74 and which is formed by a further whirling chamber facing inlet opening 83 and outlet opening 84 and whose axial extension is significantly smaller than the at least one and in particular the shorter nozzle 81. With the nozzle inlet opening 85 of the rear nozzle 82 is also associated a whirling device 87, which is also formed by a flatter whirling chamber substantially located in the nozzle axis, which faces the inlet opening 85 and is much flatter than the length of said individual nozzle and which can be constructed in one piece with the inner body 72 and/or the nozzle end plate 75. For simplifying the construction the whirling devices 86,87, as well as the associated feed lines can be constructed with a single nozzle body in one piece in such a way that only this is provided on the inner and outer end face of the associated nozzle end plate 75 with the corresponding shapes diverging from the smooth shaping, namely with corresponding depressions. Thus, through changing only a single component, the discharge nozzle 25 can be adapted to the characteristics of the fluid to be atomized. It is also conceivable to provide three or more individual nozzles, e.g. for successively feeding compressed air into the medium flow or for supplying the medium or two or more different media in separate streams to the discharge nozzle 25.

The rear individual nozzle 82 or its whirling device 87 is connected by means of a channel portion 88 provided as an end portion to the medium outlet channel 24, whilst the front individual nozzle 81 or its whirling device 86 can be connected by means of a channel portion 89 constructed as an end portion to a compressed air channel 90 connected to outlet valve 54. The cross-sectionally angular medium channel portion 88 is formed by corresponding grooves on the inner circumferential surface and on the inner end face of the inner nozzle cap 71 and is bounded by these and by the inner body 72 and is also connected by means of an intermediate channel to the outer end of piston shaft 21 or outlet channel 24, the intermediate channel is tightly closed with respect to the compressed air guide between inner body 72 and the cap end wall of handle 22. The compressed air channel portion 89 is also angular and about the nozzle axis with respect to the channel portion 88 is

appropriately diametrically displaced between the cap circumferential surfaces and the nozzle end plates 74,75 of nozzle caps 70,71 and is formed by corresponding axial and radial grooves, which can be located on the outer face of nozzle cap 71, but in the represented embodiment are located on the inside of nozzle cap 70. In the compressed air channel 90 is located the annular clearance receiving the valve spring 66 and up to which approximately extends the compressed air channel portion 89 with its axial portion.

The radial end portions of channel portions 88,89 are substantially radially or tangentially connected to the in each case associated whirling chamber, so that the conveyed medium flows in rotating or whirling manner about the nozzle axis in the vicinity of the associated nozzle inlet openings 85,83 and thus enters the associated nozzle channel.

The described construction forms an at least two-stage or multistage atomizer 100, with which the medium flow is preatomized in the vicinity of the whirling device 87 and individual nozzle 82 to material droplets with a size of e.g. 50 to 70 μm and is then more finely atomized at least once by compressed air acceleration and as a result of the subsequent air atomization the material droplet or particle size is reduced by approximately a power of ten. This is particularly the case if the dimensions for obtaining a Laval effect are such that the compressed air flow accelerates the material droplets or particles approximately to or even above the speed of sound and they are further broken up on meeting the atmosphere directly on leaving nozzle opening 80 and accompanied by impact force. For forming the nozzle geometry of the front individual nozzles 81 according to the Laval effect, it is appropriate if in the vicinity of its nozzle inlet opening it has a relatively small width and then becomes very wide via a gentle, trumpet-shaped transition or conical surfaces. The smallest width of individual nozzle 81 is appropriately below 2 or 1.5 mm and is preferably below 1 mm and is over 0.1 mm, preference being given to 0.5 mm. Thus, the individual nozzle 82 constructed as a hollow cone nozzle has a minimum width of smaller size and which is approximately half the smallest width of nozzle 81 or even less than this and can be less than 0.1 mm and is

preferably between 0.1 and 0.2 mm. In the case of an air supply with a pressure of 2 bar and 10 m/s, in the described construction approximately the speed of sound is reached at the outlet from nozzle 81 and it is theoretically possible to obtain a droplet size of the atomized liquid of up to 0.632 μm , but in practice due to the compressibility of air a value of up to approximately 5 μm can be achieved.

Instead of providing a whirling device 86 for the compressed air, it is also conceivable for the arrangement or a chamber provided in place of whirling device 86 to be such that the compressed air enters in axially parallel manner to the nozzle axis and in bundled or focused form into the nozzle 81 and as a result internal frictional losses are further reduced. The axial extension of said chamber or the whirling chamber is appropriately of the same order of magnitude as the smallest width of the individual nozzle 82 or is approximately e.g. a fifth of the smallest width of nozzle 81 and is preferably below 1 mm or 0.5 mm and preferably approximately 0.1 mm.

For finer or additional atomization, it is also possible to provide in facing upstream manner with respect to the nozzle end opening 80 an impact member, against which is hurled the liquid and is consequently atomized and deflected at right angles to the nozzle axis and then the compressed air flow accelerated to sonic or supersonic speed is supplied e.g. by using the Laval effect. The nozzle exit opening for the compressed air can in this case be e.g. provided around the nozzle exit opening for the liquid or around the plate-like impact member, so that the compressed air takes over the preatomized liquid at the edge of the impact member and deflects it again parallel to the nozzle axial direction, so that the liquid droplets accelerated in this way by the compressed air are centrifuged against the atmosphere and are further disintegrated by bursting under the pressure which occurs.

However, in the represented embodiment the compressed air is admixed upstream of the individual nozzle 81, so that a medium compressed air mixture flows out through the end or single nozzle 81. Instead of the

medium nozzle being constructed as a hollow cone nozzle, it can e.g. be constructed as a full or solid cone nozzle, as a rectangular cone nozzle, as a flat jet nozzle, or e.g. as an axial whirling nozzle or a two or multi-substance nozzle, as a function of the requirements to be made on the medium to be processed. A construction as a double hollow cone nozzle is also conceivable. It can in particular be advantageous if the discharge nozzle is constructed as an ultrasonic nozzle with a longitudinal and/or circular capillary waves.

The described discharging apparatus operates according to the following process. By pressing down handle 22 with the finger of a hand otherwise holding vessel 5, both the medium pump 2 and the compressed air pump 50 start the pump stroke counter to the action of the single, joint restoring spring 20. The latter, as the valve spring, also keeps outlet valve 23 closed. After a first stroke section, e.g. corresponding to a quarter of the total stroke, the suction or pass-over valve 32 is closed and a fluid overpressure is produced in pump chamber 14, provided that filling has taken place with the medium to be discharged.

Simultaneously an overpressure is produced in the pressure chamber 62 of the upper pump provided as a pressurized gas source, the pressurized gas being compressed. The two pressure systems are in this state still completely closed or sealed with respect to one another. During the further stroke movement and as a function of the setting of the force of the two separate valve springs, on the one hand the outlet valve 23 and on the other hand the pressurized gas outlet valve 54 open. These two valves can be set in such a way that the medium outlet valve 23 opens before the pressurized gas outlet valve 54, or simultaneously therewith or after the same, so that the compressed air reaches and flows through the discharge nozzle 25 either after, with or before the medium.

The two pump flows formed by the medium and the pressurized gas are separately supplied by means of separate pipes to the discharge nozzle 25 and are only combined in the vicinity of the mixing or whirling chamber

86, after the medium has already been preatomized within the intermediate zone. Immediately following the combination of the two pressure flows, the surge-like acceleration thereof takes place in the discharge direction and at the latest immediately following the discharge through the nozzle end opening 80 this leads to a finer atomization of the medium droplets and to a very intense and therefore relatively far-reaching spray jet, which can also be very closely bundled or focussed. Thus, the discharging apparatus is suitable both for medical active substances, such as e.g. inhalation products, and for technical purposes for the spraying of lacquers, e.g. water-soluble paints, oils, for chemical substances and the like, without it being necessary to store propellant gas in vessel 5 for atomization purposes. The pressurized gas source can optionally be an e.g. cartridge-like pressurized gas reservoir with an outlet valve, which is then appropriately opened by operating handle 22.

At the latest on reaching the pump stroke end position the handle 22 is released, so that the medium outlet valve 23 closes under the tension of restoring spring 20. The pressurized gas outlet valve 54 can be adjusted in such a way that it closes before, simultaneously with or after the medium outlet valve 23, so that in the latter case the still flowing compressed air cleans or frees the discharge nozzle 25 from medium residues. After closing check valve 23, the restoring spring 20 carries with it the entire piston unit 9 and the compressed air pump cylinder 52 to the starting position, so that a vacuum builds up in the pump chamber 14 and medium is sucked into the presuction chamber 17 by a riser 47 extending approximately to the vessel bottom and arranged at the inlet passage 19.

Simultaneously under the vacuum in the pressure chamber 62, the compressed air inlet valve 53 is opened, so that in the case of closed outlet valve 54 air is sucked into the pressure chamber 62 between the rear end of piston unit 9 or pump piston 10 and the back of the compressed air pump piston 51, as well as through the latter. As soon as valve 32 has opened through freeing the valve slots 39, the liquid passes from the presuction chamber 17 into pump chamber 14, so that the latter is filled

again and the discharging apparatus is ready for the next pump stroke. In this starting position the ventilation connection to vessel 5 is tightly closed by the rear piston lip of pump piston 10, whereas during the pump stroke it is opened at the latest following the opening of pass-over valve 32. The described construction permits a very precise dosing of the medium quantity discharged per pump stroke, the discharging apparatus having a simple and compact construction, so that in substantially position-independent manner it operates equally well in the upright and overhead position and even in the latter with the piston unit in the starting position an outflow of the vessel is prevented by the discharging apparatus.

In figs. 5 to 14 the same reference numerals as hereinbefore are used for the corresponding parts, but are followed by different letters. Thus, the previous description also serves hereinafter, to the extent that there are no different features and effects.

In the embodiment according to fig. 5 the nozzle channel of the end nozzle 81a is also cross-sectionally stepped, a constant width spacing following onto the inlet opening 23a and which passes into an obtuse-angled, conical portion of roughly the same length, whose wide end forms the nozzle end opening 80a. The nozzle outlet opening 84a of nozzle 82 is formed by a cross-sectionally, acute-angled ring edge with an inner flank parallel to nozzle axis 69a. The compressed air flow or the channel portion 89a issues in the vicinity of the flow tear-off edge 91, which is located in the plane of the end face of mixing chamber 86a facing the single nozzle 81a and is so surrounded by a cross-sectionally, obtuse-angled, V-shaped annular groove that its one lateral flank forms the ring-outer flank of the tear-off edge 91. This ring groove 92 can form part of the whirling device for the compressed air, which consequently rotates about the tear-off edge 91 or its ring-outer flank. The tear-off edge can be formed by a terminal edge or a radially inwardly directed circumferential edge, as well as by the inlet region of the front individual nozzle. Here again the axial extension of nozzle 81a, optionally including the axial extension of chamber 86a, is much

smaller than that of nozzle 82a, whilst the diameter of inlet opening 83a roughly corresponds to the diameter of the lowest point of the annular groove 92.

According to fig. 6 the opening of the pressurized gas channel so surrounds the nozzle axis 69b with chamber 86b that the two pressure flows only meet in the vicinity of the nozzle channel of nozzle 81b and/or in the discharge direction following the same, the compressed air flow being supplied around the preatomized medium flow as an optionally rotary envelope flow directed axially parallel to the nozzle axis 69b. The nozzle outlet opening 84b is in this case surrounded by an annular end face 91b of individual nozzle 82b at right angles to nozzle axis 69b, whereby said end face at the outer circumference passes into the ring-inner flank of chamber 86b, which is formed by an annular groove 92b shaped into the associated end face 78b. The outer width of the end face 91b is smaller than the inner width of the inlet opening 83b, which consequently annularly surrounds the outlet opening 84b. To this end the end face 91b, which can also be frustum-shaped in obtuse-angled manner, is located at least approximately in the plane of the inlet opening 83b, whereby also a position of the outlet opening 84b between the two ends of the channel of the individual nozzle 81b or opposite its outer end or outwardly displaced with respect to opening 80b is conceivable.

To this end, the discharge nozzle 25b approximately has at least two directly adjacent individual nozzles 81b, 82b, which are arranged in succession particularly in the direction of the nozzle axis 69b and/or which are approximately concentric. Preferably one of them as the end nozzle 81b forms the nozzle end opening 80b and the other medium nozzle 82b only connected to the medium outlet passage can be set back with respect to the nozzle end opening 80b. If the individual nozzle 82b e.g. projects concentrically into individual nozzle 81b, then the annular nozzle channel bounded by these two nozzles is appropriately conically tapered outwards or e.g. in the discharge direction, so that both the outer circumference of the inner nozzle and the inner circumference of the outer nozzle is tapered, whereby the cone angle of these two

circumferential surfaces can differ in such a way that the annular nozzle channel provided for the compressed air flow slightly decreases outwards in passage cross-section. Particularly in this case, but also in other cases, the nozzle channel of the medium nozzle can have a front, funnel-shaped-widened end portion forming the associated outlet opening, so that e.g. said nozzle channel has a constriction between its ends and from which it is conically and/or stepped widened towards both ends.

Figs. 7 to 9 show two whirling devices 86c, 87c on a discharge nozzle 25c, which is constructed similar to that of fig. 6. Channel portion 89c or 88c issues into the associated whirling device 86c or 87c in the vicinity of a ring channel surrounding nozzle axis 69c, the opening being provided radially or tangentially corresponding to the associated whirling direction, so that the compressed air flows round in rotary manner in the whirling direction in ring channel 93, 94. From ring channel 93 or 94 or from its inner circumference ducts 95 or 96 branch off inwards and are bounded by guide members constructed in one piece with the associated nozzle body, have a much smaller passage cross-section than the ring channel 93 or 94 and in the associated flow direction can continuously taper or have a constant cross-section. For each whirling device there can be one, two, three, four or more ducts uniformly distributed about the central axis, appropriately the sum of the passage cross-sections of the ducts 95 or 96 being larger than that of the associated ring channel 93 or 94. The ducts 95 or 96 issue into an inner area bounded by the associated guide bodies, which in the case of the whirling device 87c is the annular space surrounding the rear end of the nozzle channel of nozzle 82c and in the case of whirling device 86c that surrounding nozzle 82c or the inlet region of nozzle 81c.

Ducts 95, 96 can issue tangentially into said associated inner area in such a way that the whirling rotation direction of both pressure flows is directed in the same or opposite directions and in the former case a particularly high acceleration is obtained and in the latter case a particularly pronounced whirling action. The whirling devices 86c, 87c or the guide bodies and the lateral boundaries of ducts 95, 96 are in

this case exclusively formed by corresponding shaping of the remote end faces of the nozzle end plate 75c or nozzle cap 71, so that the facing end faces of inner body 72c and nozzle end plate 74c can be given a planar construction and merely serve to bound the channels and chambers on one side. However, it is also conceivable to only guide the liquid via a whirling chamber and to allow the air to flow out directly from the nozzle via an annular passage, or conversely only to guide the air via a whirling chamber.

Fig. 10 shows a double rotation discharge nozzle 25d, in which the medium in the nebulizing or whirling device 87d in a first stage is brought into a corresponding flow pattern and then in a second whirling or nebulizing device 86d is brought into a whirling flow directed in the same or opposite direction and in particular accompanied by acceleration. For this purpose, the discharge opening 84d of the nozzle channel of nozzle 82d issues outside nozzle axis 69d and/or opposite to the same in sloping manner and in the present embodiment there is a nozzle channel sloping by approximately 45° or more with respect to nozzle axis 69d and whose inlet opening 85d is positioned eccentrically or in spaced manner with respect to nozzle axis 69d. The supply of compressed air can take place in the whirling chamber 86d or in a further, following and separate chamber.

Fig. 11 shows a discharging apparatus 1e, in which the handle 22e at the start of its operating path associated with the pump stroke only operates the compressed air pump 50e and then the medium pump 2e and preferably there is an operating rod for both pumps, formed in the present case by piston rod 21e and this has a stop-limited idle movement up to the carrying along or operation of the medium pump 2e. Instead of this or in addition thereto, the arrangement can also be such that the handle 22e at the end of the pump stroke of medium pump 2e and up to the following further operation of the compressed air pump 50e, has a following or residual path or travel, so that pump 50e can be further operated over a residual stroke following the end of the stroke of pump 2e in a continuation of its already performed pump stroke.

In the first case, due to the idle movement prior to the start of the stroke of medium pump 2e or before or after closing its inlet or pass-over valve and at least in the pressure chamber 62e an overpressure is built up or even, in the case of a corresponding matching of the outlet valve 54e constructed as a spring-loaded plate valve, prior to the opening of the medium outlet valve 23e compressed air is passed into the discharge nozzle 25e. In the second case, following the end of the stroke of medium pump 2e compressed air is further supplied to the discharge nozzle 25e and as a result it can be cleaned or blown free of residual medium particles.

To this end, in the embodiment according to fig. 11, the piston rod 21e is constructed as a tubular telescopic rod spring-loaded towards the stretched position and whose outer rod part 97 forms a component with pump piston 10e and whose other, inner rod part 98, is connected firmly to the handle 22e via insert 64e. The two rod parts 97,98 engage in one another in the vicinity of the pressure chamber 62e between the compressed air pump piston 51e and the end face of bush 63e and on the end face of the inner rod part 98 is supported by one end a stretching spring 99 in the form of a helical compression spring, whose other end is supported with respect to the rod part 97 and, as shown, can also be supported on the presuction piston 11e or on the valve closing part 26e of medium outlet valve 23e, so that the stretching spring 99 acts counter to the valve spring thereof and on reaching a predetermined spring tension can then initiate the substantially displacement-dependent opening of outlet valve 23e.

By itself or in conjunction with a further spring only acting following a predetermined relative displacement of rod parts 97,98, the stretching spring 99 can have a stepped-spring characteristic in such a way that the resistance exerted by spring 99 in a first step is so small compared with the tension of the restoring spring of medium pump 2e, that at the start of the operating path of handle 22e only the compressed air pump 50e is operated, whilst medium pump 2e remains unoperated. In a second step, the resistance of the stretching spring 99 suddenly increases to such an extent compared with the restoring spring of medium

pump 2e that this is operated substantially synchronously with the compressed air pump 50e. At the end of the travel of medium pump 2e, a residual path can be available for operating the compressed air pump 50e against the increased resistance of the stretching spring 99. The pump stroke end position of the compressed air pump 50e is appropriately limited by the handle 22e striking against piston unit 9e or against the end face of the rod part 97 of piston rod 21e, against which strikes the end face of bush 63e or insert 64e.

Whereas in the embodiment according to figs. 1 to 3, the outlet channel 24e is provided on the outer circumference of shaft 28, in the embodiment of fig. 11 it is provided in the interior of the tubular shaft 28e. In the embodiment according to figs. 1 to 3 the pump chamber 14, if it has not yet been filled with medium, can consequently be relatively easily ventilated in that at the end of the stroke of medium pump 2, the pump piston 10 is stop-fixed and then by further pressing of handle 22 via dog 40 outlet valve 23 can be opened mechanically or in displacement-dependent manner. There is no such arrangement in the embodiment according to fig. 11, but it would be conceivable if the dog reached the end of shaft 28e just prior to the pump stroke end position of compressed air pump 50e. Shaft 28e is displaceably guided in the rod part 98 and is surrounded by the stretching spring 99 located within rod part 97.

As is further shown in fig. 11, the compressed air pump 50e or the handle 22e is stop-limited in the starting position with respect to a casing part, particularly with respect to the sleeve 46e or stop 59e of cylinder casing 3e of medium pump 2e. For this purpose, the pump piston 52e is provided at its end with an inwardly directed collar as the stop 101 and with it is associated as a counterstop 102 a collar of cylinder casing 3e projecting over the outer circumference and located in the vicinity of the counter member for snap element 58e. Stop 101 and counterstop 102 can be so in sealing engagement with one another in the starting position that the air supply to the compressed air pump 50e and the ventilation for the vessel are hermetically outwardly sealed.

Whereas in the embodiment according to fig. 11 the medium outlet valve 23e is positioned horizontally in the vicinity of pump piston 10e or in the associated cylinder housing 3e and the medium outlet channel 24e in the flow direction behind the same is connected in the outlet valve 23e issuing into the annulus between shaft 28e and rod part 97e via transverse bores in shaft 28e, in the embodiment according to fig. 12 the medium outlet valve 23f is provided outside the cylinder housing 3f in the vicinity of the compressed air pump 50f or within the pin bush 67f of handle 22f and in this case the handle or the compressed air pump cylinder 52f forms a component of piston shaft 21f. As shown, the outlet valve 23f can be constructed in the manner of a needle or pin valve, as a check valve, as a separate, medium pressure-influenced control piston-operated valve and in particular as a hose valve according to German Patent 29 02 624.

Discharge valve 53f is located very close to the discharge nozzle 25f or immediately on the side of inner body 72f remote therefrom, so that between it and the nozzle channel is only provided the angular channel portion 88f, in which only small medium residues can remain and which can be easily cleaned or blown free by corresponding reversal of the compressed air. In the represented embodiment the compressed air outlet valve 54f is a spring-loaded ball valve, whose valve casing formed by the cylinder casing of the compressed air pump or handle 22f is located between the pump axis and discharge nozzle 25f in such a way that it is directly connected to one leg of the compressed air channel portion 89f. In this case the compressed air pump cylinder 52f engages with a small gap in the inner circumference of the collar-like part 59f, which like the partition 8f is constructed in one piece with cap 4f constructed as a screwcap.

In this embodiment the medium pump 2f does not have double piston and instead only has a single pump piston 10f on piston unit 9f and this is essentially formed by an annular piston disk, over whose front and/or rear end projects a frustum-like widened piston lip. The front piston lip in the pump stroke end position engages on the bottom wall 18f formed

by an offset ring shoulder and in the direction towards the inlet channel 19 it passes into a multiply offset, outer circumferentially reduced end portion of cylinder casing 3f. In said end portion is provided a check valve as the suction valve 32f in the form of a ball valve with a spherical valve closing part 33f and a conical valve seat 34f.

The cylinder casing 3f is constructed in one piece with the ring flange 6f projecting over the outer circumference at its outer end and which is supported with its free end face on partition 8f and can be so braced with the remote, annular end face against the vessel neck that it forms a seal corresponding to gasket 42.

At the outer end cylinder 12 or cylinder casing 3f is closed by a ring or bush-like cylinder cover 7f traversed by the piston shaft 21f and by means of the collar projecting over its outer circumference is sealed into an inner groove of ring flange 6f in such a way that it is also axially supported on partition 8f. An inner frustum-shaped end of the cylinder cover 7f projecting into the circumferential surface of cylinder casing 3f and on the outer circumference corresponding to the rear piston lip of pump piston 10f in the initial position of said pump piston engages as a stop with a relatively sharp ring edge on pump piston 10f or on the rear end face of its piston disk, so that a seal is also obtained against the compressed air pump 50f.

The piston shaft 21 is displaceable out of the starting position with respect to the pump piston 10f by an idle movement, by means of which the pump 50f is operated, whereas the medium pump 2f remains unoperated through pump piston 10f remaining stationary. At the end of the idle movement, the piston shaft 21f strikes by a dog against the back of the piston disk of pump piston 10f and then moves it with it up to its stroke end position. The dog 103 located outside the compressed air pump 50f in the starting position within the cylinder cover 7f is formed by a ring shoulder of piston shaft 21f, which is in turn formed by the end face of the rod part 98f connected to pump cylinder 52f or handle 22f or constructed in one piece therewith and which can form an external cross-sectionally reduced extension of socket or bush 67f.

Particularly in the case of a displaceable mounting of the valve closing part 26f of the medium outlet valve 23f, piston shaft 21f is constructed in the manner of a telescopic rod, whose inner, tubular rod part 28f forming the outlet channel 24f is formed in the vicinity of the associated end of the valve closing part 26f. The piston shaft 22f or the rod part 28f passes through the pump piston 10f in the vicinity of a passage opening in the piston disk, whereby on the inner circumference of pump piston 10f there is at least one sealing lip for the sealed guidance on the outer circumference of said rod part 28f. On the end located within pump chamber 14f, the rod part 28f has a rod collar 105 projecting over its outer circumference, or a comparable driving member for the return stroke of pump piston 10f, which can strike against the associated end face of the piston disk and can be supported on the restoring spring 40f.

The outer and inner piston lips 56f and 57f of the pump piston 51f of the compressed air pump 50f, in this embodiment are axially reciprocally displaced by more than the stroke of the medium pump 2f or the compressed air pump 50f, the inner piston lip 57f being located substantially within the ring flange 6f or the cylinder casing 3f, whilst the outer piston lip 56f is outwardly displaced and can extend at least up to the outer end of the collar 59f or beyond the same. The pump piston 51f is centered in the cylinder cover 7f or ring flange 6f and also in the partition 8f and is inserted in sealed manner except for the air supply and for this purpose between its bottom wall and the piston lip 56f has a multiply stepped, profiled circumferential surface part on the outer circumference.

Fig. 13 shows an advantageous construction of a control device 106 for an opening of the medium outlet channel 24h or the compressed air channel 90h or both channels delayed with respect to the travel of handle 22h. There is preferably a control piston 107 influenced by the compressed air pressure in the compressed air chamber 62h for operating at least one movable valve body 27h or 65h. Control piston 107 spring-loaded in the closing direction is constructionally combined with the valve body 65h

of the compressed air outlet valve 54h, with which it forms a cup-shaped collar sleeve, whose collar provided at one end forms the valve body 65h and which is closed at the other end by a ring disk-like bottom wall, which with a shoulder projecting counter to the flow direction in piston shaft 21h forms the valve seat 27h, with which can be associated as the valve closing part 26h a part firmly seated in piston shaft 21h or movable with shaft 28h.

The circumferential surface of control piston 107 is displaceably guided on the outer circumference of the associated end of piston shaft 21h or the sleeve part of insert 64h surrounding the same about the opening path of the two valves with respect to the common valve spring 66h. For the reciprocal sealing of the two passage paths, namely passage portion 88h on the one hand and passage portion 89h and the compressed air passage 90h on the other, the control piston 107 is sealingly guided on a running path of bush 63 with a sealing lip 108 located in the vicinity of its bottom wall, said running path being provided following on to the annular clearance for valve spring 66h.

The control device 106 for the joint control of both the pressurized gas and also the medium with respect to its release to the discharge nozzle 25h on reaching the predetermined pressure in pressure chamber 62h, opens both nozzles simultaneously or successively in that through said overpressure initially the valve closing part 65h of outlet valve 54h is transferred into the open position. Thus, the control piston 107 is entrained by the valve closing part 65h, so that the valve seat 27h provided thereon rises simultaneously or in delayed manner from the valve closing part 26h and consequently also opens. Correspondingly and conversely the medium outlet valve 23h can close again simultaneously with or prior to the compressed air outlet valve 54h. Thus, the control device 107 has at least one valve leading to the medium nozzle and at least one leading to the compressed air nozzle, preferably that leading to the compressed air nozzle opens before and/or closes after the other valve.

Fig. 14 shows a control device 106i for reversing at least part of the compressed air flow from the pressure chamber in at least a part and in particular the end part following onto the discharge nozzle 25i or in the latter and preferably a control piston 107i influenced by the compressed air pressure is provided for operating at least one movable valve body. Instead of this or in addition thereto, it is also conceivable to have the control piston influenced by the pressure in the medium outlet channel 24i.

In this case the compressed air outlet valve 54i is constructed as a slide valve and not as a plate valve and the sleeve-like valve closing part in the manner of a ring sealing lip is provided as a valve slide on the outer circumference of control piston 107i and is movable both into and out of the area of the valve slots on an inner circumferential surface of the compressed air channel 90i enclosing the ring gap for valve spring 66i. The valve slots 109 can be provided in simple manner on the collar-like casing of insert 64i. In the case of an overpressure in the compressed air chamber of compressed air pump 50i the annular control piston 107i, from which the valve closing part 65i projects in the direction of the pressure chamber, is so displaced counter to the tension of valve spring 66i that the sealing lip of valve closing part 65i passes from a valve slot-free area into the area of the valve slots 109, so that the compressed air can pass from the compressed air chamber into the compressed air channel 90i.

Control device 106i or control piston 107i operates a further air closing valve 110, for which a further, corresponding sleeve-like valve closing part 111 projecting in the same direction and similar to valve closing part 65i is provided on the inner circumference of control piston 107i. With said valve closing part 111 is associated at least one or a ring of uniformly distributed valve openings 112 on an outer circumferential surface, said valve openings 112 being provided in simple manner in the sleeve part of insert 64i in the form of radial bores and issue into an annular channel between the associated end of piston shaft 21i, as well as its sleeve part and from there into the medium channel portion 88i.

In the starting position, the compressed air outlet valve 54i and the slide closing valve 110 are closed by the associated valve closing parts 65i, 111.

Under the rising compressed air overpressure, the control piston 107i is initially moved over a partial path and consequently the air closing valve 110 is

5 opened so that the compressed air flows in the liquid path or channel portion 88i. As the compressed air strikes against the liquid simultaneously conveyed in the medium channel portion 88i, a backwash occurs and optionally through the pressure further rising in the compressed air chamber, the control piston 107i is moved further counter to the tension of valve spring 66i, so that now
10 the initially closed compressed air outlet valve 54i opens and the compressed air can flow to the channel portion 89i. If the liquid flow is interrupted, e.g. at the end of the medium pump stroke, then the outlet valve 54i closes due to the lack of the backwash to counterpressure, so that the control piston 107i now moves back by the corresponding partial path. However, the closing valve 110
15 remains open, so that the air which is still under pressure in the compressed air chamber into the associated liquid paths or channel portions and cleans the same, including the discharge nozzle 25i. It is also conceivable to control this reversal mechanically or in displacement-dependent manner.

20 Independently of the illustrated combination of two separate pressure sources for two separate media, namely e.g. a liquid to be discharged and a pressurized gas to another fluid, the individual components of the discharging apparatus, e.g. the pumps, their components, the valves, the control means and the discharge nozzles, constitute feature combinations essential to the invention.

25



THE CLAIMS DEFINING THE INVENTION ARE AS FOLLOWS:

1. A manually operable discharging apparatus comprising
a discharge nozzle having at least one discharge opening
5 leading into the open, said discharge nozzle having
cooperating first and second distributing nozzles
providing first and second nozzle exit openings defined
by end portions of first and second nozzle ducts, at
least one of said first distributing nozzles providing a
10 rear nozzle exit opening located upstream of a front
nozzle exit opening of at least one of said second
distributing nozzles, wherein said at least one first
distributing nozzle is an atomizing nozzle, thereby
providing in at least two steps a first atomization of
15 the medium to an atomized flow and at least one
subsequent further atomization of said atomized flow.

2. A discharging apparatus according to claim 1,
wherein said at least one first distributing nozzle
20 provides a preatomized entry of the medium into at least
one of spaces defined by at least one of said second
distributing nozzle and at least one mixing chamber for
mixing a first medium issuing from said first
distributing nozzle and a second medium entering said
25 mixing chamber separate from said first medium.

3. A discharging apparatus according to any preceding
claim, wherein means are provided for pre-atomizing said
medium before mixing with a second flow of medium inside
30 said discharge nozzle.

4. A discharging apparatus according to any preceding
claim, wherein said rear nozzle opening is located behind
said second nozzle duct.

35



5. A discharging apparatus according to any preceding claim, wherein said rear nozzle opening is located at a distance behind said second nozzle duct.

5 6. A discharging apparatus according to any preceding claim, wherein at least one entry chamber is directly connected to an upstream associated entry end of at least one of said first and second nozzle ducts, at least one of said first and second nozzle ducts having a stepwise
10 width change between said associated entry end and an associated one of said nozzle exit openings.

7. A discharging apparatus according to claim 6, wherein at least one of said at least one entry chamber
15 is wider than said associated nozzle duct, thereby providing at least one of chambers defined by a first entry chamber connecting to said entry end of said first nozzle duct and a second entry chamber connecting to said entry end of said second nozzle duct.

20 8. A discharging apparatus according to any preceding claim, wherein at least one of said first and second nozzle ducts has at least one of longitudinal sections defined by a section of constant width and a section
25 having a width narrowing in a downstream direction.

9. A discharging apparatus according to any preceding claim, wherein said first nozzle duct has a continuously narrowing section connecting downstream to a section of
30 constant width providing said rear nozzle exit opening.

10. A discharging apparatus according to any of claims 7 to 9, wherein said rear nozzle exit opening is issuing into said second entry chamber.

35



11. A discharging apparatus according to any of claims 7
to 10, wherein said rear nozzle exit opening is
surrounded by an annular chamber section of said second
entry chamber, said chamber section being associated with
5 a rear end face of said second entry chamber.

12. A discharging apparatus according to claim 11,
wherein said first distributing nozzle provides an inner
boundary flank of said annular chamber section.
10

13. A discharging apparatus according to any preceding
claim, wherein said rear nozzle exit opening is
surrounded by an end face of said second distributing
nozzle.
15

14. A discharging apparatus according to any of claims 6
to 13, wherein at least one of said at least one entry
chamber is bounded by a core body engaging into a cap-
shaped nozzle body providing an associated one of said
20 nozzle ducts.

15. A discharging apparatus according to claim 14,
wherein for supplying at least one of said nozzle ducts
with media at least one of said nozzle bodies has at
25 least one of ducts provided by a longitudinal duct and a
radial duct.

16. A discharging apparatus according to any preceding
claim, wherein for mixing said medium with a gaseous
30 fluid said discharge nozzle is provided with at least one
of profilings defined by longitudinal and circular
profilings.

17. A discharging apparatus according to any preceding
35 claim, wherein a flow of medium is transversely directed
against said rear nozzle exit opening.



18. A discharging apparatus according to any preceding claim, wherein said rear nozzle exit opening is bounded by an annulus providing an inner flank, an outer flank and a rip-off edge for the medium, a flow of medium
5 issuing in the vicinity of said rip-off edge.

19. A discharging apparatus according to any preceding claim, wherein an impact bouncing means is provided for deflecting the medium in at least one of directions
10 defined by a transverse direction transverse to a nozzle exit direction and a main direction in accordance with said nozzle exit direction.

20. A discharging apparatus according to any preceding claim, wherein an impact bouncing means is provided for the medium at at least one of locations defined by a location upstream of said at least one discharge opening and a location in a path of an exit direction of said first distributing nozzle.
15

21. A discharging apparatus according to claim 19 or 20, wherein said bouncing means is provided for firstly deflecting the medium in said transverse direction and secondly in said main direction.
20

22. A discharging apparatus according to any preceding claim, wherein means are provided for deflecting the medium towards and at an edge opposing one of said nozzle exit openings.
25

23. A discharging apparatus according to any preceding claim, wherein means are provided for conducting a first medium and a second medium at an edge opposing one of said nozzle exit openings, thereby taking over the first
30 medium in a pre-atomized state by the second medium.
35



24. A discharging apparatus according to any of claims
19 to 23, wherein said means comprise an impact atomizing
member exposed to a liquid medium flow issuing from said
rear nozzle exit opening and to an accelerated gaseous
5 medium flow.

25. A discharging apparatus according to any preceding
claim, wherein means are provided for accelerating the
medium to a velocity between substantially sonic and
10 supersonic speed.

26. A discharging apparatus according to any of claims
22 to 25, wherein an accelerating means is provided for
accelerating the gaseous medium to a velocity between
15 substantially sonic and supersonic speed prior to taking
over and deflecting the liquid medium at said edge.

27. A discharging apparatus according to any preceding
claim, wherein means are provided for directing the
20 medium issuing from said rear nozzle exit opening in a
direction inclined to an exit direction of said discharge
nozzle.

28. A discharging apparatus according to any preceding
25 claim, wherein said second nozzle duct has a smallest
width extension smaller than one of extensions defined by
2mm, 1.5mm, 1mm and 0.5mm.

29. A discharging apparatus according to any preceding
30 claim, wherein said first nozzle duct has a smallest
width extension smaller than a smallest width extension
of said second nozzle duct by one of degrees defined by
substantially one half and less than one half.

35 30. A discharging apparatus according to any preceding
claim, wherein an inner entry end of said second nozzle
duct is opposed by a depression provided in an end face



located substantially in a plane of said entry end.

31. A discharging apparatus according to any preceding claim, wherein said first nozzle duct is penetrating a
5 nozzle body in the vicinity of remote inner and outer end faces, said outer end face having a depression radially adjacent to said rear nozzle exit opening.

32. A discharging apparatus according to claim 30 or 31,
10 wherein said depression is an annular depression surrounding said rear nozzle exit opening.

33. A discharging apparatus according to any preceding claim, wherein said rear nozzle exit opening is bounded
15 by a sharp edge.

34. A discharging apparatus according to any of claims 2 to 33, wherein means are provided for deflecting a flow of the second medium by a flow of the first medium
20 substantially in an exit direction of at least one of said first and second distributing nozzles.

35. A discharging apparatus according to any preceding claim wherein control means are provided for a delayed
25 opening of at least one of flow paths defined by said medium outlet duct and a compressed air channel, a control member exposed to an air pressure being provided for operating at least one valve body.

30 36. A discharging apparatus according to any preceding claim, wherein a medium pump to be operated with a handle is provided, a medium outlet duct leading to said discharge nozzle and a control means being provided for diverting at least part of a compressed air flow into at
35 least one of said ducts defined by an end portion of said medium outlet duct and said discharge nozzle, a control member being provided and operated as a function of at



least one of a pressure of compressed air and a pressure in said medium outlet duct, said control member operating at least one valve body.

5 37. A discharging apparatus according to claim 35 or
claim 36, wherein said control means has at least one
first valve leading to a compressed air nozzle of said
discharge nozzle and at least one second valve leading to
10 a medium nozzle of said discharge nozzle, means being
provided for opening and closing said first valve with
respect to said second valve in at least one of time
shifted manners defined by an advanced opening and a
delayed closing.

15 38. A discharging apparatus according to any preceding
claim, wherein a medium pump to be operated with a handle
is provided, said medium outlet duct leading to said
discharge nozzle, a manually operable compressed air pump
being associated with said medium pump and connected to a
20 compressed air duct portion, means being provided for
operating said compressed air pump in an initial
operating phase of said handle prior to said medium pump.

25 39. A discharging apparatus substantially as
hereinbefore described with reference to the accompanying
drawings.

Dated this 24th day of October, 1991

30 ING. ERICH PFEIFFER GmbH & Co. KG
By its Patent Attorneys
DAVIES & COLLISON



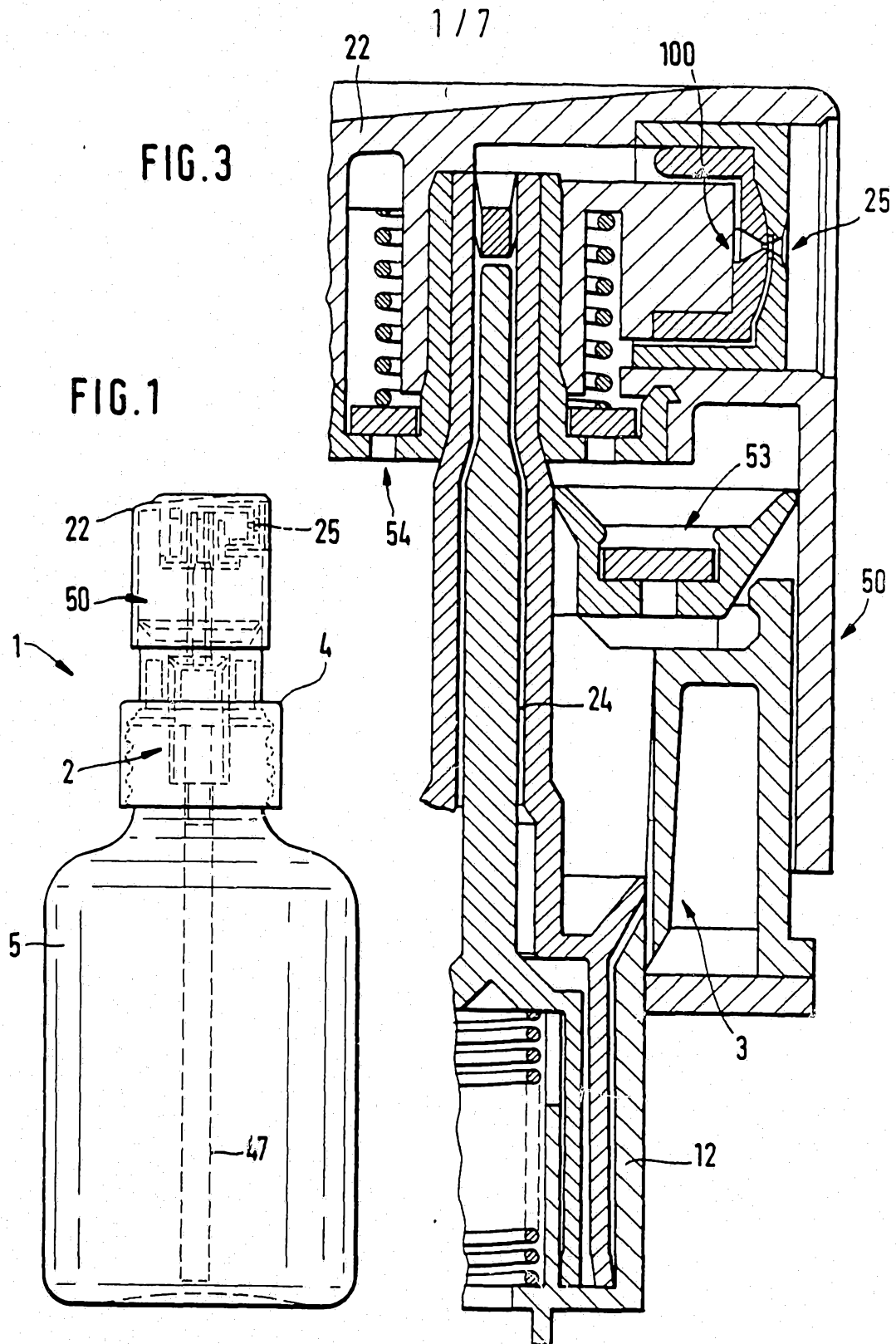

2/7

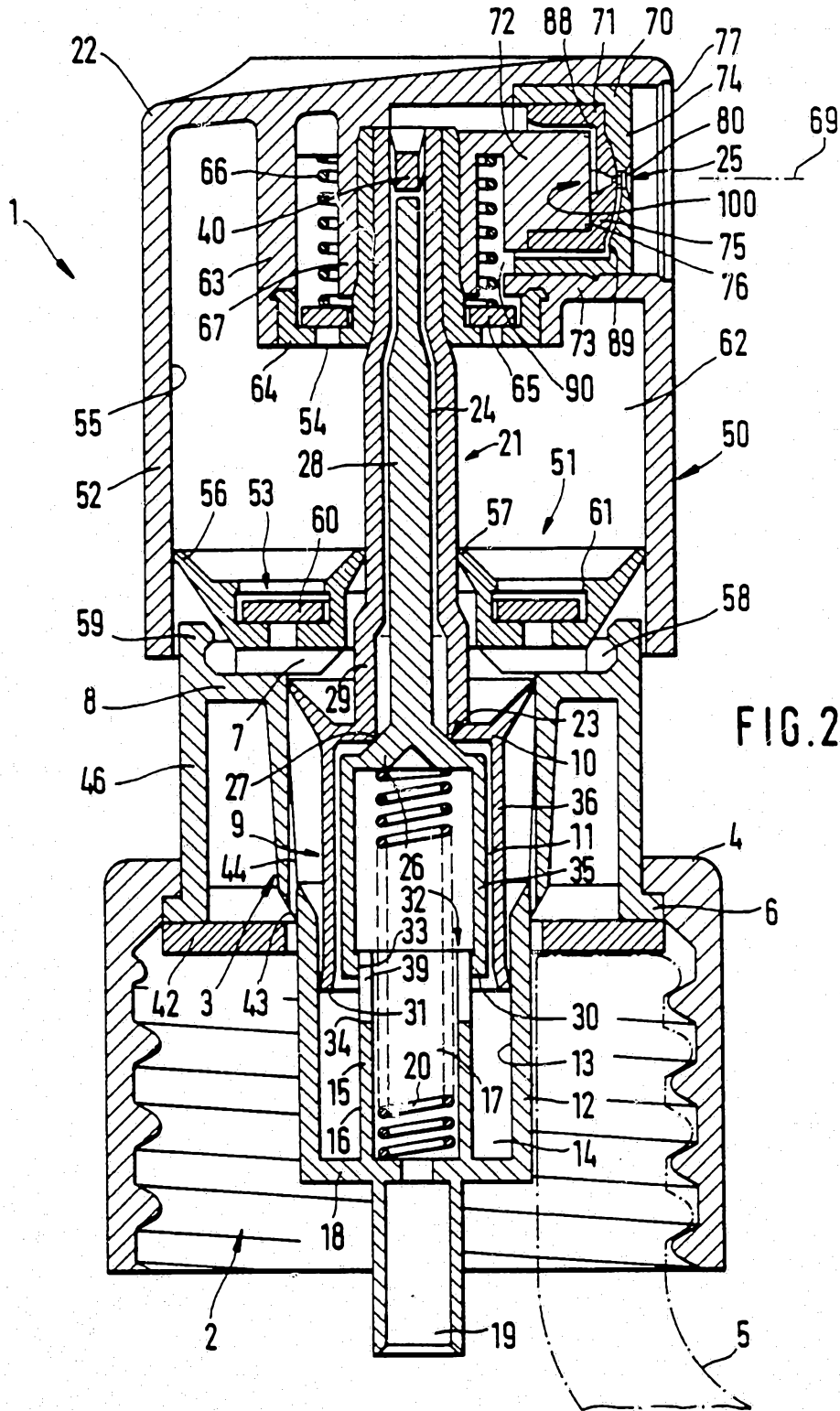

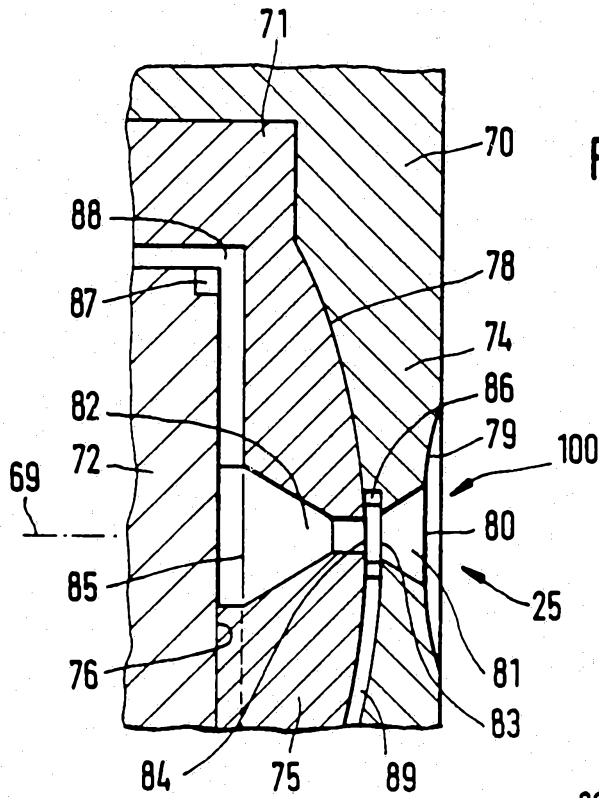

FIG. 4

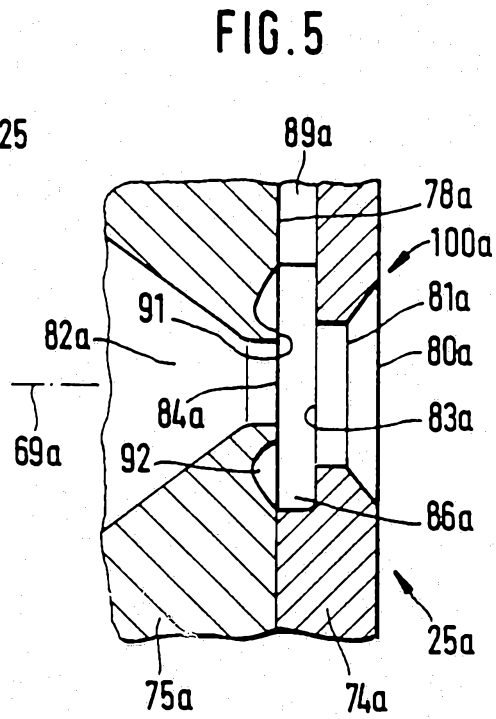

FIG. 5

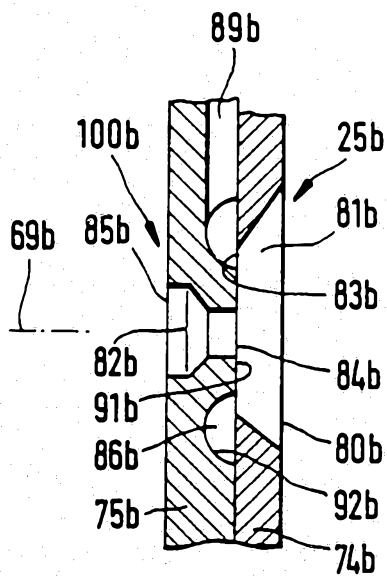

FIG. 6

4/17

FIG. 7

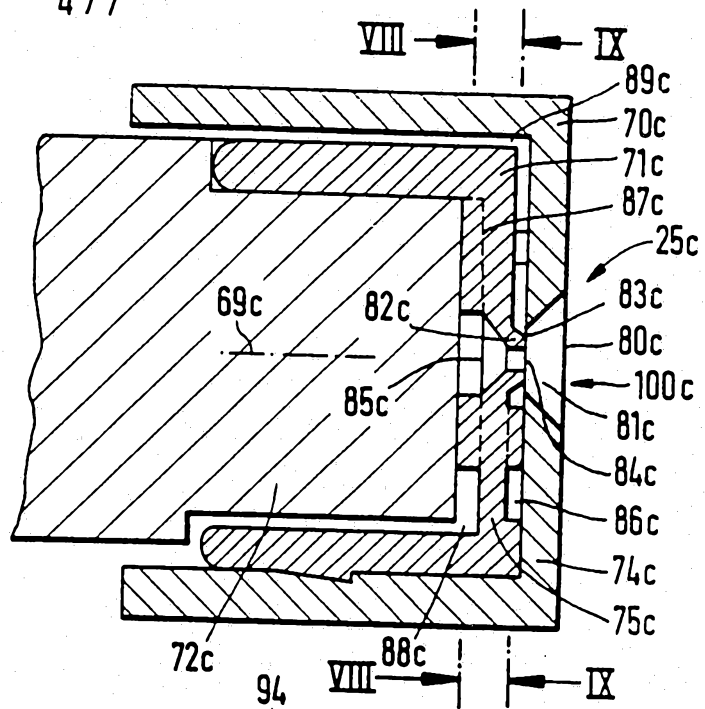

FIG. 9

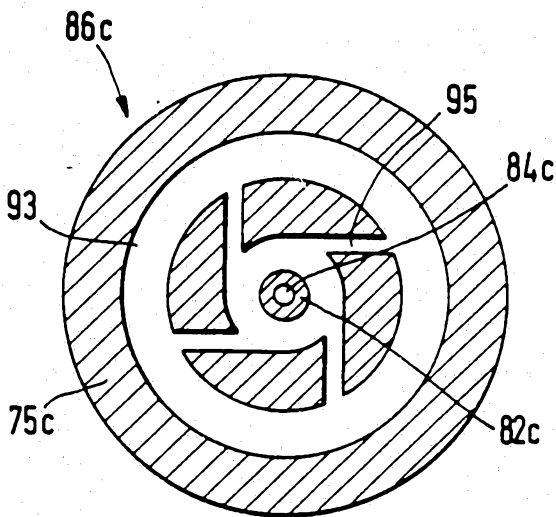

FIG. 8

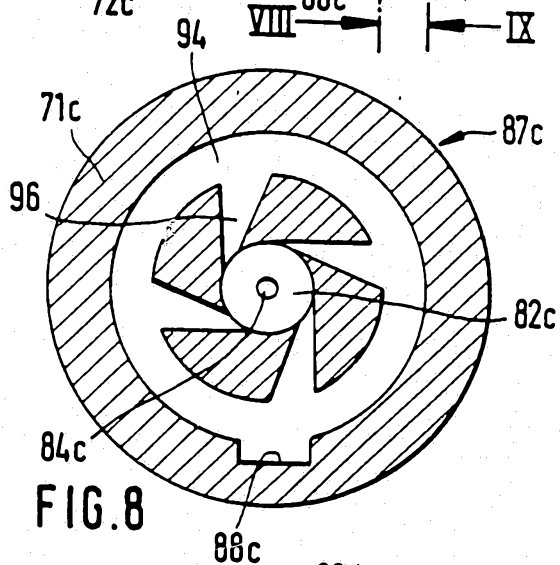

FIG. 10

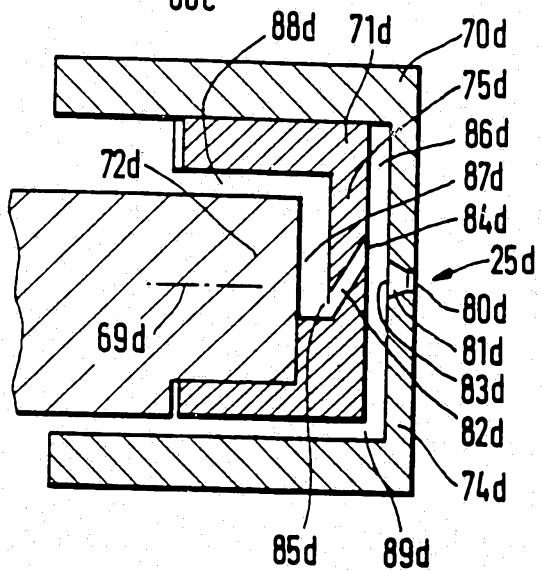

FIG. 11

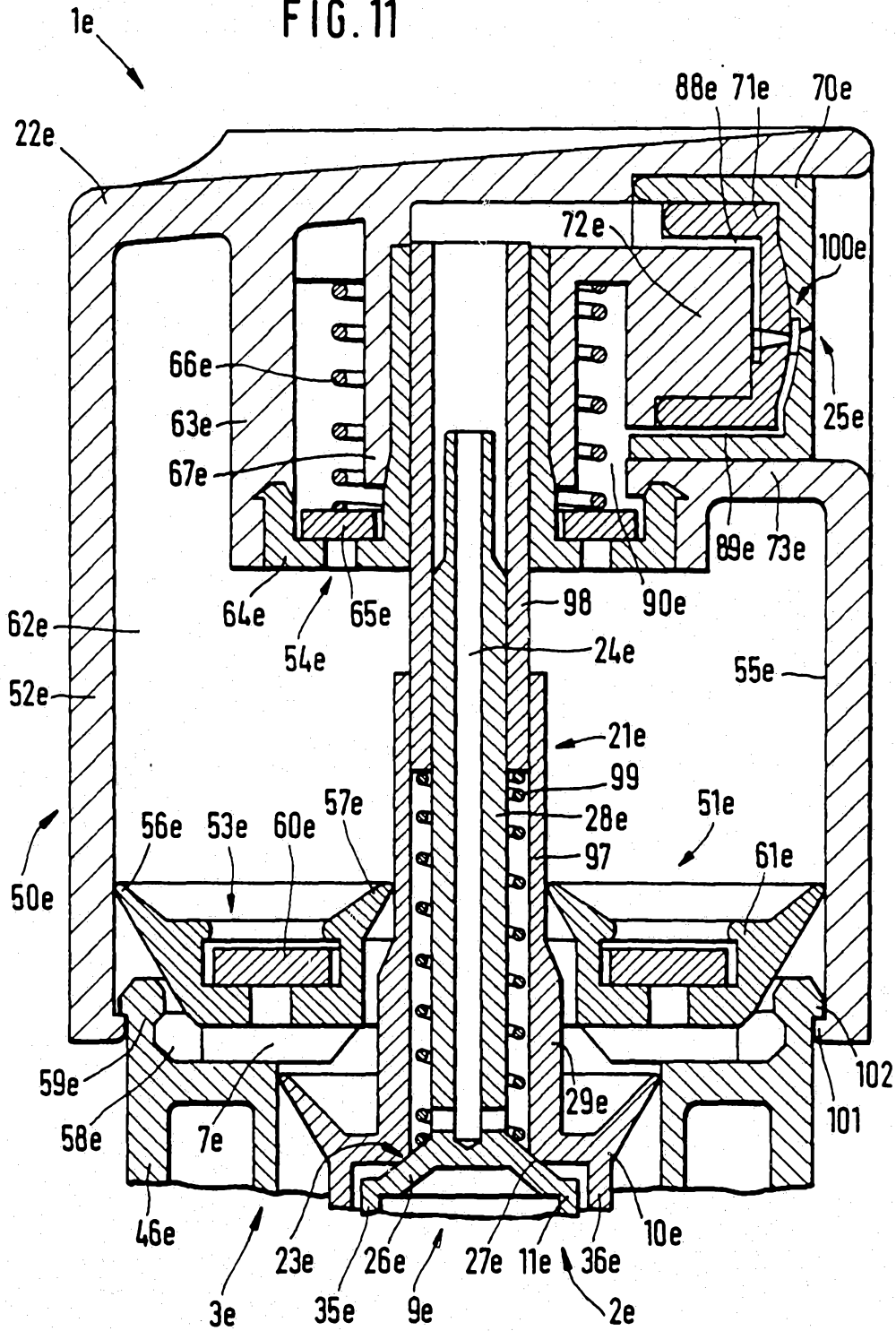

FIG. 12

6/7

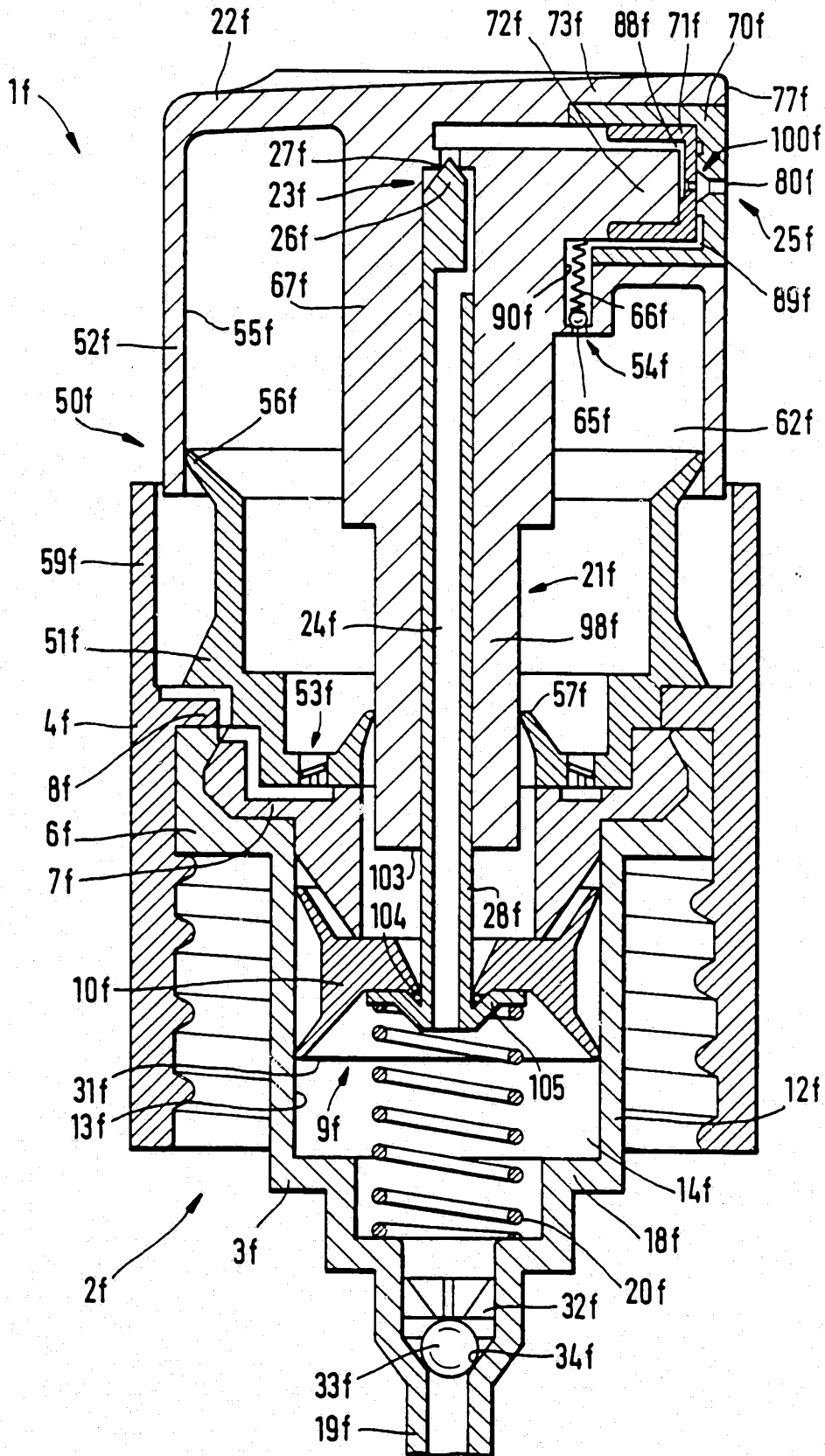

FIG. 13

7/7

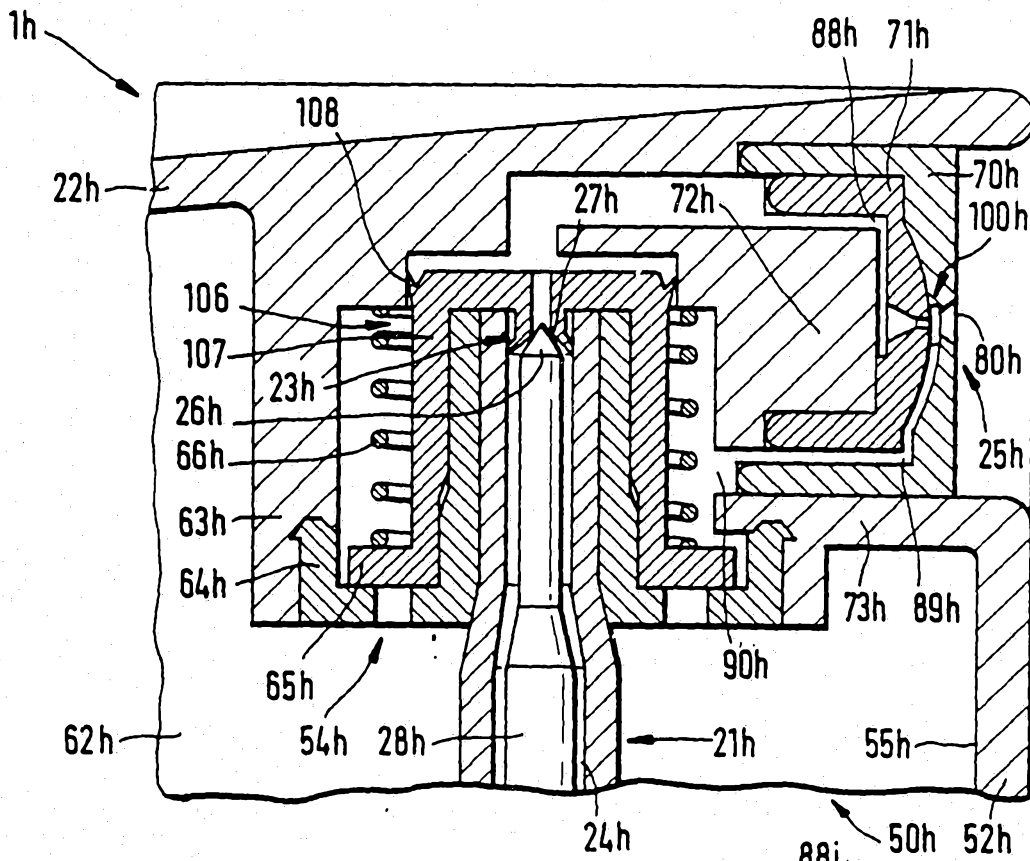
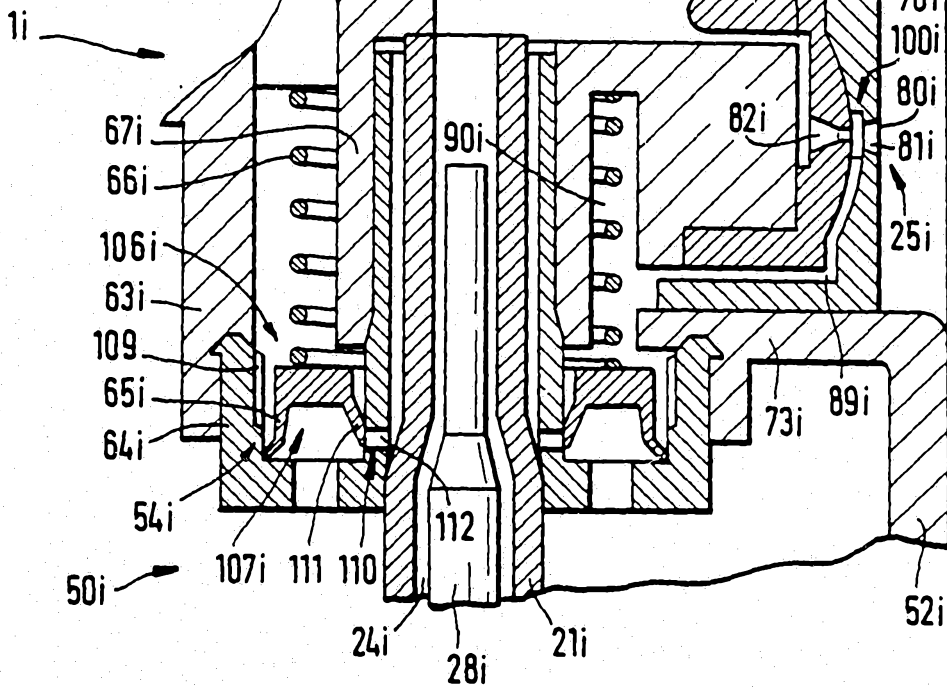

FIG. 14



INTERNATIONAL SEARCH REPORT

International Application No. PCT/EP 88/00598

I. CLASSIFICATION OF SUBJECT MATTER (If several classification symbols apply, indicate all) ⁶		
According to International Patent Classification (IPC) or to both National Classification and IPC		
Int.Cl ⁴ B 05 B 11/06; B 05 B 7/10		
II. FIELDS SEARCHED		
Minimum Documentation Searched ⁷		
Classification System	Classification Symbols	
Int.Cl ⁴	B 05 B	
Documentation Searched other than Minimum Documentation to the Extent that such Documents are Included in the Fields Searched ⁸		
III. DOCUMENTS CONSIDERED TO BE RELEVANT ⁹		
Category [*]	Citation of Document, ¹¹ with indication, where appropriate, of the relevant passages ¹²	Relevant to Claim No. ¹³
Y	EP, A, 0217744 (KOCH) 8 April 1987, see column 2, lines 44-56; column 3, line 52 - column 4, line 49; column 6, lines 29-46; figures 1-7 --	1-4,6-9, 12,16
Y	US, A, 4179049 (UMSTEAD) 18 December 1979, see column 5, lines 3-18; figures 1-3 --	1-4,6-9, 12,16
A	US, A, 3945574 (POLNAUER et al.) 23 March 1976, see column 1, lines 8-58; column 3, line 11 - column 4, line 12; figures 1-16 --	1-4,6-12
A	FR, A, 1144776 (JAÏNE) 17 October 1957, see figures 3,4 -----	5
<p>[*] Special categories of cited documents: ¹⁰</p> <p>"A" document defining the general state of the art which is not considered to be of particular relevance</p> <p>"E" earlier document but published on or after the International filing date</p> <p>"L" document which may throw doubts on priority claim(s) or which is cited to establish the publication date of another citation or other special reason (as specified)</p> <p>"O" document referring to an oral disclosure, use, exhibition or other means</p> <p>"P" document published prior to the international filing date but later than the priority date claimed</p> <p>"T" later document published after the international filing date or priority date and not in conflict with the application but cited to understand the principle or theory underlying the invention</p> <p>"X" document of particular relevance; the claimed invention cannot be considered novel or cannot be considered to involve an inventive step</p> <p>"Y" document of particular relevance; the claimed invention cannot be considered to involve an inventive step when the document is combined with one or more other such documents, such combination being obvious to a person skilled in the art.</p> <p>"&" document member of the same patent family</p>		
IV. CERTIFICATION		
Date of the Actual Completion of the International Search	Date of Mailing of this International Search Report	
23 September 1988 (23.09.88)	17 October 1988 (17.10.88)	
International Searching Authority	Signature of Authorized Officer	
European Patent Office		

**ANNEX TO THE INTERNATIONAL SEARCH REPORT
ON INTERNATIONAL PATENT APPLICATION NO.**

EP 8800598

SA 23229

This annex lists the patent family members relating to the patent documents cited in the above-mentioned international search report. The members are as contained in the European Patent Office EDP file on 11/10/88. The European Patent Office is in no way liable for these particulars which are merely given for the purpose of information.

Patent document cited in search report	Publication date	Patent family member(s)	Publication date
EP-A- 0217744	08-04-87	DE-U- 8621135	29-01-87
US-A- 4179049	18-12-79	Keine	
US-A- 3945574	23-03-76	Keine	
FR-A- 1144776		Keine	

EPO FORM P0479

For more details about this annex : see Official Journal of the European Patent Office, No. 12/82

INTERNATIONALER RECHERCHENBERICHT

Internationales Aktenzeichen PCT/EP 88/00598

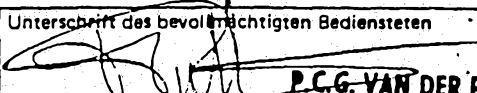
I. KLASSIFIKATION DES ANMELDUNGSGEGENSTANDS (bei mehreren Klassifikationssymbolen sind alle anzugeben) ⁶		
Nach der Internationalen Patentklassifikation (IPC) oder nach der nationalen Klassifikation und der IPC		
Int. Cl. ⁴ .. B 05 B 11/06; B 05 B 7/10		
II. RECHERCHIERTE SACHGEBIETE		
Recherchierter Mindestprüfstoff ⁷		
Klassifikationssystem	Klassifikationssymbole	
Int. Cl. ⁴	B 05 B	
Recherchierte nicht zum Mindestprüfstoff gehörende Veröffentlichungen, soweit diese unter die recherchierten Sachgebiete fallen ⁸		
III. EINSCHLÄGIGE VERÖFFENTLICHUNGEN⁹		
Art*	Kennzeichnung der Veröffentlichung ¹¹ , soweit erforderlich unter Angabe der maßgeblichen Teile ¹²	Betr. Anspruch Nr. ¹³
Y	EP, A, 0217744 (KOCH) 8. April 1987, siehe Spalte 2, Zeilen 44-56; Spalte 3, Zeile 52 - Spalte 4, Zeile 49; Spalte 6, Zeilen 29-46; Figuren 1-7	1-4,6-9, 12,16
Y	US, A, 4179049 (UMSTEAD) 18. Dezember 1979, siehe Spalte 5, Zeilen 3-18; Figuren 1-3	1-4,6-9, 12,16
A	US, A, 3945574 (POLNAUER et al.) 23. März 1976, siehe Spalte 1, Zeilen 8-58; Spalte 3, Zeile 11 - Spalte 4, Zeile 12; Figuren 1-16	1-4,6-12
A	FR, A, 1144776 (JAINE) 17. Oktober 1957, siehe Figuren 3,4	5
<p>* Besondere Kategorien von angegebenen Veröffentlichungen¹⁰:</p> <p>"A" Veröffentlichung, die den allgemeinen Stand der Technik definiert, aber nicht als besonders bedeutsam anzusehen ist</p> <p>"E" älteres Dokument, das jedoch erst am oder nach dem internationalen Anmeldedatum veröffentlicht worden ist</p> <p>"L" Veröffentlichung, die geeignet ist, einen Prioritätsanspruch zweifelhaft erscheinen zu lassen, oder durch die das Veröffentlichungsdatum einer anderen im Recherchenbericht genannten Veröffentlichung belegt werden soll oder die aus einem anderen besonderen Grund angegeben ist (wie ausgeführt)</p> <p>"O" Veröffentlichung, die sich auf eine mündliche Offenbarung, eine Benutzung, eine Ausstellung oder andere Maßnahmen bezieht</p> <p>"P" Veröffentlichung, die vor dem internationalen Anmeldedatum, aber nach dem beanspruchten Prioritätsdatum veröffentlicht worden ist</p> <p>"T" Spätere Veröffentlichung, die nach dem internationalen Anmeldedatum oder dem Prioritätsdatum veröffentlicht worden ist und mit der Anmeldung nicht kollidiert, sondern nur zum Verständnis des der Erfindung zugrundeliegenden Prinzips oder der ihr zugrundeliegenden Theorie angegeben ist</p> <p>"X" Veröffentlichung von besonderer Bedeutung; die beanspruchte Erfindung kann nicht als neu oder auf erfinderischer Tätigkeit beruhend betrachtet werden</p> <p>"Y" Veröffentlichung von besonderer Bedeutung; die beanspruchte Erfindung kann nicht als auf erfinderischer Tätigkeit beruhend betrachtet werden, wenn die Veröffentlichung mit einer oder mehreren anderen Veröffentlichungen dieser Kategorie in Verbindung gebracht wird und diese Verbindung für einen Fachmann naheliegend ist</p> <p>"&" Veröffentlichung, die Mitglied derselben Patentfamilie ist</p>		
IV. BESCHEINIGUNG		
Datum des Abschlusses der internationalen Recherche		Absenddatum des internationalen Recherchenberichts
23. September 1988		17 OCT 1988
Internationale Recherchenbehörde		Unterschrift des bevollmächtigten Bediensteten
Europäisches Patentamt		 P.C.G. VAN DER PUTTEN

**ANHANG ZUM INTERNATIONALEN RECHERCHENBERICHT
 ÜBER DIE INTERNATIONALE PATENTANMELDUNG NR.**

EP 8800598
 SA 23229

In diesem Anhang sind die Mitglieder der Patentfamilien der im obengenannten internationalen Recherchenbericht angeführten Patentdokumente angegeben.
 Die Angaben über die Familienmitglieder entsprechen dem Stand der Datei des Europäischen Patentamts am 11/10/88
 Diese Angaben dienen nur zur Unterrichtung und erfolgen ohne Gewähr.

Im Recherchenbericht angeführtes Patentdokument	Datum der Veröffentlichung	Mitglied(er) der Patentfamilie	Datum der Veröffentlichung
EP-A- 0217744	08-04-87	DE-U- 8621135	29-01-87
US-A- 4179049	18-12-79	Keine	
US-A- 3945574	23-03-76	Keine	
FR-A- 1144776		Keine	

EPO FORM P073

Für nähere Einzelheiten zu diesem Anhang : siehe Amtsblatt des Europäischen Patentamts, Nr.12/82