



US00D776840S

(12) **United States Design Patent**
Youn

(10) **Patent No.:** **US D776,840 S**

(45) **Date of Patent:** **** Jan. 17, 2017**

- (54) **HEAD LAMP OF CAR**
- (71) Applicant: **GM GLOBAL TECHNOLOGY OPERATIONS LLC**, Detroit, MI (US)
- (72) Inventor: **Dae-Young Youn**, Incheon (KR)
- (73) Assignee: **GM GLOBAL TECHNOLOGY OPERATIONS LLC**, Detroit, MI (US)

D707,861 S *	6/2014	Lai	D26/28
D721,196 S *	1/2015	Lai	D26/28
D728,135 S *	4/2015	Ha	D26/28
D740,978 S *	10/2015	Lee	D26/28
D749,763 S *	2/2016	Sa	D26/28
D752,254 S *	3/2016	Futschik	D26/28
D756,005 S *	5/2016	Handt	D26/28
D757,970 S *	5/2016	Binder	D26/28
D760,413 S *	6/2016	Shim	D26/28
D761,981 S *	7/2016	Tsutamori	D26/28

- (**) Term: **15 Years**
- (21) Appl. No.: **29/532,687**
- (22) Filed: **Jul. 9, 2015**

* cited by examiner

Primary Examiner — Angela J Lee
(74) *Attorney, Agent, or Firm* — Ohlandt, Greeley, Ruggiero & Perle, L.L.P.

(30) **Foreign Application Priority Data**

Jan. 9, 2015 (KR) 30-2015-0001196

- (51) **LOC (10) Cl.** **26-05**
- (52) **U.S. Cl.**
USPC **D26/28**

- (58) **Field of Classification Search**
USPC D26/28–36; 362/459–468, 475–478, 362/485–487
CPC F21S 48/00; F21S 48/10; F21S 48/115; F21S 48/225; F21S 48/1233; F21S 48/1266; F21S 48/1388; F21S 48/2268; F21V 21/04
See application file for complete search history.

(57) **CLAIM**

The ornamental design for a head lamp of car, as shown and described.

DESCRIPTION

The patent or application file contains at least one photograph. Copies of this patent or patent application publication with the drawings and/or photographs will be provided by the Office upon request and payment of the necessary fee. FIG. 1 is a perspective view of a new design for a head lamp of car as shown in the drawings; FIG. 2 is a front elevation view; FIG. 3 is a rear elevation view; FIG. 4 is a first side elevation view; FIG. 5 is a second side elevation view, opposite of the first side elevation view; FIG. 6 is a top plan view; and, FIG. 7 is a bottom plan view.

(56) **References Cited**

U.S. PATENT DOCUMENTS

D593,233 S *	5/2009	Bai	D26/28
D686,356 S *	7/2013	Morgenstern	D26/28

1 Claim, 7 Drawing Sheets

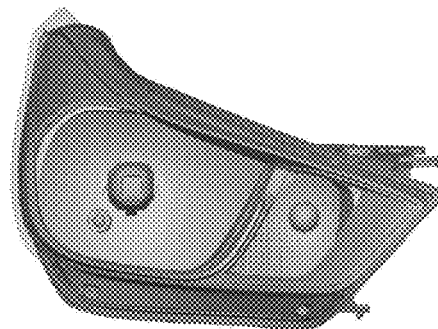
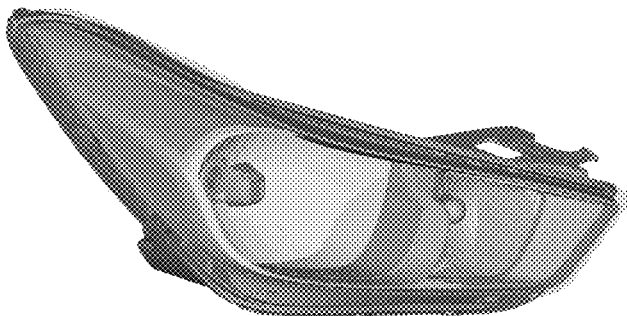

Fig. 1

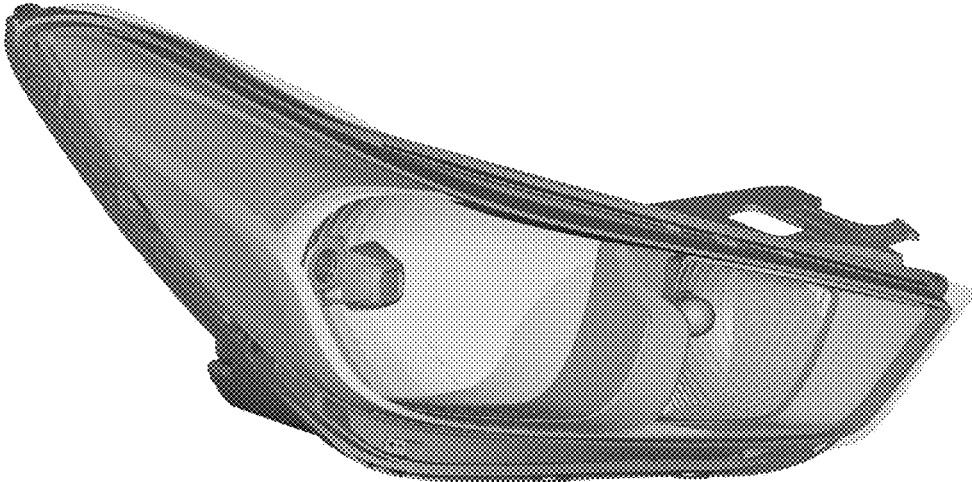

Fig. 2

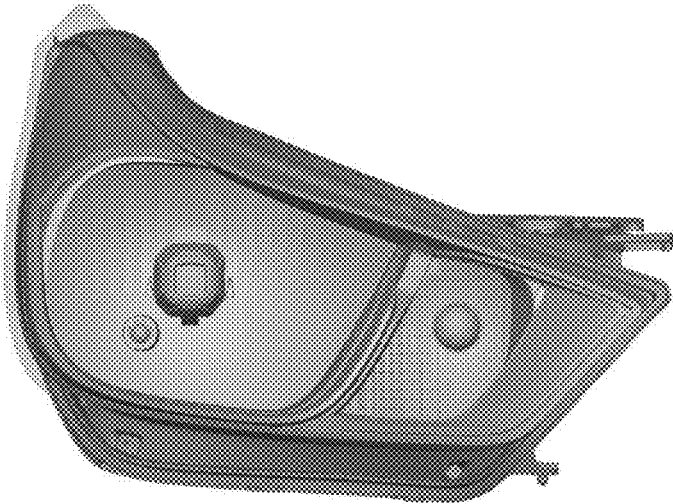

Fig. 3

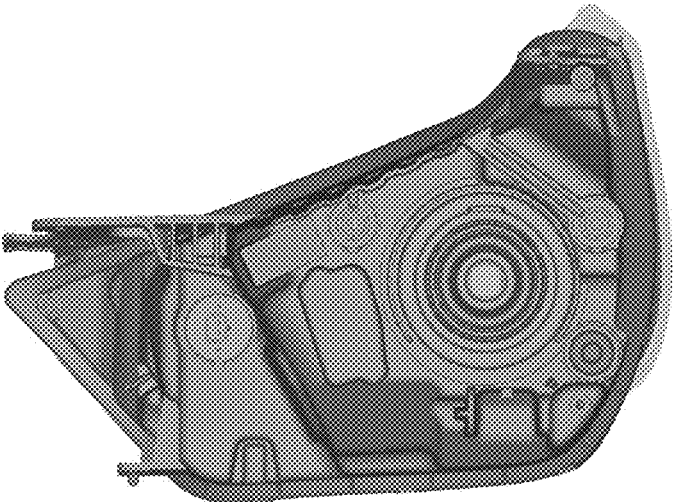

Fig. 4

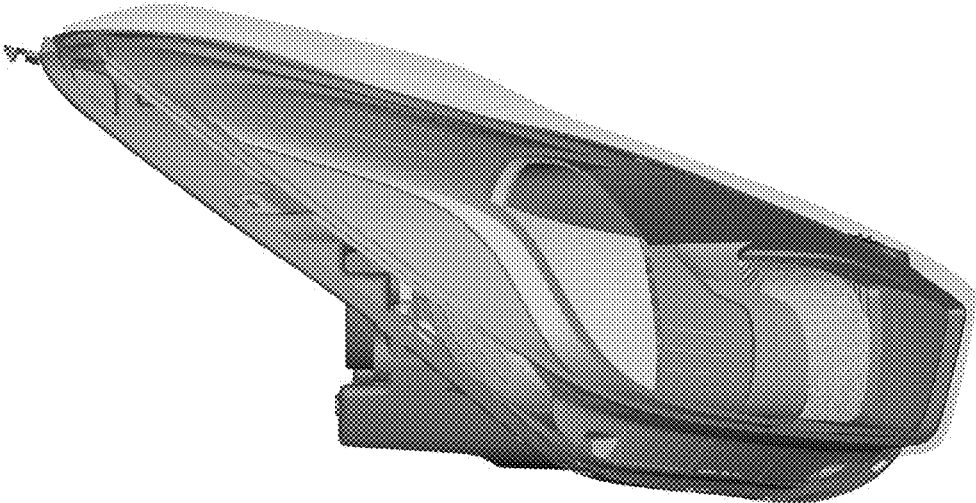

Fig. 5

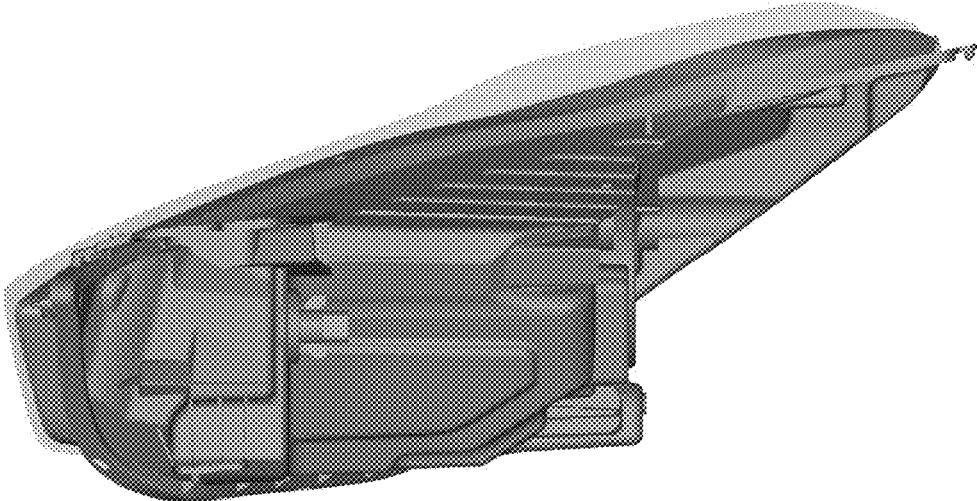

Fig. 6

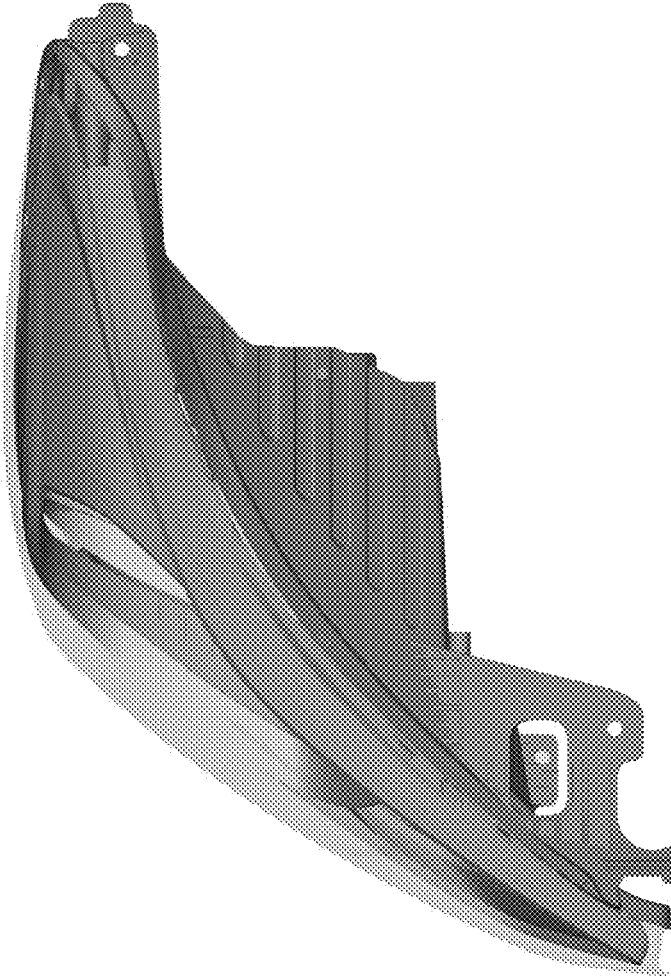

Fig. 7

