



(51) International Patent Classification:

F24F 11/30 (2018.01) F24F 11/62 (2018.01)
F24F 11/61 (2018.01)

(21) International Application Number:

PCT/US2021/065712

(22) International Filing Date:

30 December 2021 (30.12.2021)

(25) Filing Language:

English

(26) Publication Language:

English

(30) Priority Data:

17/139,322 31 December 2020 (31.12.2020) US

(71) Applicant: **GOODMAN MANUFACTURING COMPANY LP** [US/US]; 5151 San Felipe, Suite 500, Houston, TX 77056 (US).

(72) Inventors: **NOTARO, Douglas**; 10506 Star Thistle Ct., Cypress, TX 77433 (US). **DOGRA, Adway**; 14144 Mueschke Road, Apt 6207, Cypress, TX 77433 (US). **DE, Tathagata**; c/o Goodman Manufacturing Company LP, 5151 San Felipe, Suite 500, Houston, TX 77056 (US).

(74) Agent: **CARBONE, Frederick et al.**; Baker Botts LLP, 910 Louisiana Street, Houston, TX 77002 (US).

(81) Designated States (unless otherwise indicated, for every kind of national protection available): AE, AG, AL, AM, AO, AT, AU, AZ, BA, BB, BG, BH, BN, BR, BW, BY, BZ, CA, CH, CL, CN, CO, CR, CU, CZ, DE, DJ, DK, DM, DO, DZ, EC, EE, EG, ES, FI, GB, GD, GE, GH, GM, GT, HN, HR, HU, ID, IL, IN, IR, IS, IT, JO, JP, KE, KG, KH, KN, KP, KR, KW, KZ, LA, LC, LK, LR, LS, LU, LY, MA, MD, ME, MG, MK, MN, MW, MX, MY, MZ, NA, NG, NI, NO, NZ, OM, PA, PE, PG, PH, PL, PT, QA, RO, RS, RU, RW,

(54) Title: SYSTEMS AND METHODS FOR CONTROLLING A HEATING AND AIR-CONDITIONING (HVAC) SYSTEM

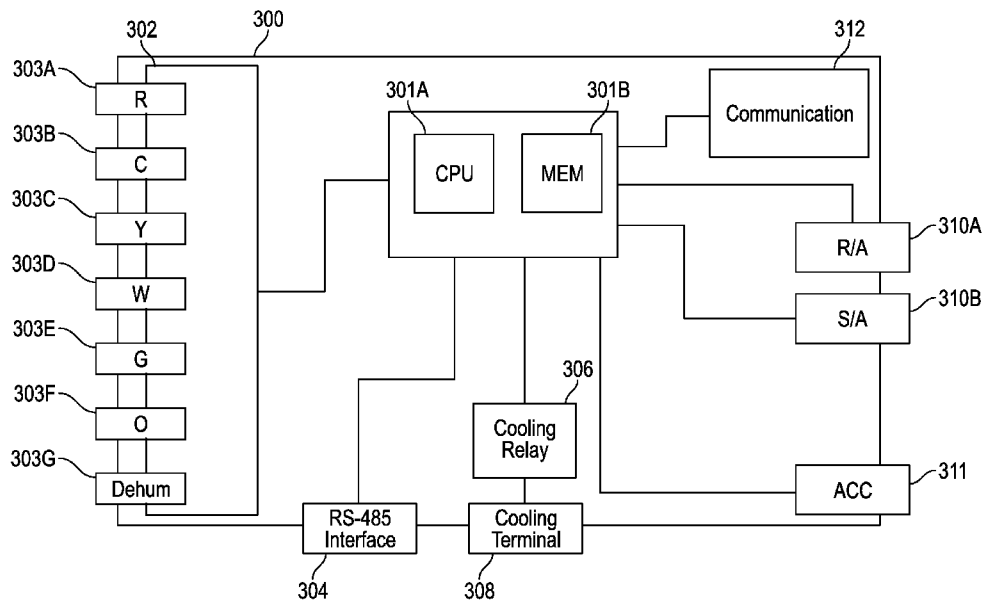

FIG. 3

(57) Abstract: A system and method for controlling indoor climate of a building. The system includes one or more equipment of a heating ventilation and air-conditioning (HVAC) system, a thermostat configured to wirelessly transmit operational data and a controller communicatively coupled to the one or more equipment and the thermostat. The controller includes a communication module configured to exchange the operational data with the thermostat and an equipment interface configured to communicate control signals to the one or more equipment to control operation of the one or more equipment. The controller is configured to receive the operational data wirelessly transmitted from the thermostat using the communication module, determine based on the operational data a control plan to operate the one or more equipment of the HVAC system, and operate the one or more equipment of the HVAC system based on the control plan.



SA, SC, SD, SE, SG, SK, SL, ST, SV, SY, TH, TJ, TM, TN,
TR, TT, TZ, UA, UG, US, UZ, VC, VN, WS, ZA, ZM, ZW.

- (84) Designated States** (*unless otherwise indicated, for every kind of regional protection available*): ARIPO (BW, GH, GM, KE, LR, LS, MW, MZ, NA, RW, SD, SL, ST, SZ, TZ, UG, ZM, ZW), Eurasian (AM, AZ, BY, KG, KZ, RU, TJ, TM), European (AL, AT, BE, BG, CH, CY, CZ, DE, DK, EE, ES, FI, FR, GB, GR, HR, HU, IE, IS, IT, LT, LU, LV, MC, MK, MT, NL, NO, PL, PT, RO, RS, SE, SI, SK, SM, TR), OAPI (BF, BJ, CF, CG, CI, CM, GA, GN, GQ, GW, KM, ML, MR, NE, SN, TD, TG).

Published:

- *with international search report (Art. 21(3))*
- *before the expiration of the time limit for amending the claims and to be republished in the event of receipt of amendments (Rule 48.2(h))*

5 exchanged between communicating thermostats and communicating HVAC equipment, there are significant tradeoffs. First, communicating thermostats and HVAC equipment are generally more expensive than their non-communicating counterparts, making communicating systems cost prohibitive for many consumers. Second, communicating systems are generally inoperable with non-communicating equipment, older equipment, and equipment from different manufacturers.

10 As a result, consumer choice is extremely limited regarding equipment to be used in a communicating system. Moreover, this lack of interoperability limits the ability of a consumer to retrofit or upgrade a system without a relatively complete replacement. Finally, while many of the features and capabilities of communicating systems make installation and setup much easier, many of these features have limited use for the end user.

15 In contrast, legacy thermostats and HVAC equipment generally rely on simpler control signals, such as on/off-type signals (typically 24VAC signals), for communication and control. As a result, interoperability is generally less of a concern in HVAC systems implementing only legacy equipment, and consumers are given more flexibility in installing equipment that better suit their specific needs and budget. As used herein, the term “legacy” refers to equipment that

20 has the ability to connect with a thermostat that sends 24VAC on/off signals.

In light of the above, there is a need for a system that provides the improved degree of control afforded by a communicating system while allowing a broad range of thermostats and other HVAC equipment to be used within the system. Preferably, the system would allow for both communicating and non-communicating legacy equipment and the device discovery and

25 configuration processes would occur using several methods alone or in combination and may include reading or retrieving information provided by an installer, customer, or other user; reading or retrieving information available in a remote database; reading or retrieving information directly from the HVAC equipment; or learning the properties of the HVAC equipment using a trial and error approach.

30

5

SUMMARY

Examples of systems and methods are provided for control of the air temperature of a building. For instance, examples of systems and methods are provided for operating a HVAC system according to a control plan based on a target time. The control plan may be designed to reach a desired air temperature in a building in the target time.

10

The system may include a controller that is coupled to indoor and/or outdoor HVAC units. The controller may include equipment terminals for controlling either communicating or non-communicating HVAC units. The controller may be communicatively coupled to a thermostat. The controller may also include sensor terminals which may be communicatively coupled to one or more air temperature sensors. The controller may also include accessory terminals for connecting devices such as indoor air quality equipment and dampers and other zoning equipment.

15

The controller may include a communication module. The communication module may be communicatively coupled with a computer device using a wired or wireless connection. The communication module may be used to send or receive performance and operation data relating to the HVAC system. The computer device may use the performance and operation data to analyze the HVAC system, providing for maintenance and optimized performance. The computer device may also be used to input control plan parameters such as target time and desired temperature.

20

The method for controlling the air temperature of a building may include discovering connected devices. The method may further include determining a target time and an initial control plan. The control plan may include operating one or more HVAC units at a variety of capacity or stage settings to achieve high performance or efficiency ratings. The control plan may then be executed by a controller in response to a heating/cooling call. The controller may then determine a satisfy time based on how long it takes to satisfy the heating/cooling call using the control plan. The actual satisfy time may then be compared with the target time and used to

30

5 update the control plan. The method may then be repeated using the updated control plan when a new heating/cooling call is received.

These and various other features and advantages will be apparent from a reading of the following detailed description and drawings along with the appended claims. While embodiments of this disclosure have been depicted and described and are defined by reference to
10 exemplary embodiments of the disclosure, such references do not imply a limitation on the disclosure, and no such limitation is to be inferred. The subject matter disclosed is capable of considerable modification, alteration, and equivalents in form and function, as will occur to those skilled in the pertinent art and having the benefit of this disclosure. The depicted and described
15 embodiments of this disclosure are examples only, and not exhaustive of the scope of the disclosure.

5

BRIEF DESCRIPTION OF THE DRAWINGS

A more complete understanding of the present embodiments and advantages thereof may be acquired by referring to the following description taken in conjunction with the accompanying drawings, in which like reference numbers indicate like features, and wherein:

FIG. 1 shows an HVAC system incorporating an existing thermostat, according to some
10 embodiments;

FIG. 2 shows an HVAC system operating without a thermostat, according to some
embodiments;

FIG. 3 is an illustrative embodiment of a controller for use in an HVAC system; and

FIG. 4 is a flow chart illustrating an embodiment of a method for controlling the air
15 temperature of a building using a control plan based on a target time.

5

DESCRIPTION

This disclosure generally relates to a system for controlling a heating ventilation and air-conditioning (HVAC) system and methods of controlling HVAC equipment in the HVAC system.

For purposes of this disclosure, an HVAC system refers to any system that provides one or
10 more of heating, cooling, or ventilation to an environment, such as a building. The building can be, but is not limited to, a residential building such as a home, apartment, condominium, or similar. An HVAC system may include one or more pieces of HVAC equipment for providing heating, cooling, or ventilation. HVAC equipment includes, but is not limited to, furnaces, air-conditioners, heat pumps, blowers, air handlers, and dehumidifiers. HVAC equipment may be
15 operable at one stage of operation only (i.e., single stage), at one of multiple discrete stages of operation (i.e., multi stage), or along a continuum of operational points, such as with modulating furnaces or inverter air-conditioning units. HVAC equipment may also operate using gas, electricity, or any other suitable source of energy.

The present disclosure is directed to an HVAC system comprising a controller. In certain
20 embodiments, the controller is incorporated into one or more component of the HVAC system, such as a thermostat or piece of HVAC equipment, and communicatively coupled to other HVAC system components. In other embodiments, the controller is a standalone unit communicatively coupled to HVAC system components.

The controller operates by attempting to satisfy heating or cooling calls received by the
25 controller within a specified target time. To do so, the controller determines an initial control plan for satisfying the heating/cooling call at a target time and then proceeds to operate the HVAC system based on the initial control plan. The controller then compares the actual time taken to satisfy the heating/cooling call to the target time and adjusts the control plan accordingly. The new control plan may then be implemented in the subsequent heating/cooling
30 cycle. Based on the results of comparing the actual satisfy time to the target time in the

5 subsequent cycle, the control plan may again be adjusted. This process may repeat continuously, gradually converging on a control plan that satisfies the heating/cooling plan in as close to the target time as possible.

The control plan comprises settings at which HVAC equipment is to be run in order to satisfy the heating/cooling call. The control plan may comprise instructions corresponding to one
10 or more of what equipment is to be run, how long a piece of equipment is to be run, and, if the equipment is capable of being run at more than one stage or capacity, the particular stage or capacity the equipment is to be run. For example, if an HVAC system includes a three-stage air-conditioning and is required to satisfy a cooling call within a 20 minute target time, the control plan may comprise instructions to operate the air conditioner at the second stage for 15 minutes
15 and the first stage for 5 minutes.

In certain embodiments, the control plan may be adjusted if the actual satisfy time is greater than or less than the target time. For example, if the actual satisfy time is greater than the target time, the current parameters of the control plan are generally inadequate to provide sufficient heating or cooling. Accordingly, the controller may change the operating equipment,
20 timing, or capacity parameters of the control plan to provide more heating or cooling as necessary. Conversely, if the actual satisfy time is less than the target time, it may be assumed that the current parameters of the control plan are too aggressive. As a result, the controller may change the operating equipment, timing, or capacity parameters of the control plan to provide less heating or cooling.

25 The present disclosure is now described in detail with reference to one or more embodiments thereof as illustrated in the accompanying drawings. In the following description, numerous specific details are set forth in order to provide a thorough understanding of the present disclosure. However, the present disclosure may be practiced without some or all of these specific details. In other instances, well known process steps and/or structures have not
30 been described in detail in order not to unnecessarily obscure the present disclosure. In addition,

5 while the disclosure is described in conjunction with the particular embodiments, it should be understood that this description is not intended to limit the disclosure to the described embodiments. To the contrary, the description is intended to cover alternatives, modifications, and equivalents as may be included within the spirit and scope of the disclosure as defined by the appended claims.

10 FIG. 1 is a schematic depiction of an HVAC system 100 in accordance with an embodiment of this disclosure. As depicted, HVAC system 100 is incorporated into a building 101. The HVAC system 100 includes a controller 102. Controller 102 is depicted as being incorporated into and communicatively coupled with an indoor unit 104. Indoor unit 104 may comprise, but is not limited to, heating equipment such as a furnace. Controller 102 is also
15 communicatively coupled to an outdoor unit 106, which may comprise, but is not limited to, cooling equipment such as an air conditioner. Other examples of indoor and outdoor units include but are not limited to air handlers and heat pumps, respectively. Controller 102 is further communicatively coupled to a thermostat 108.

During operation, controller 102 receives heating or cooling calls from thermostat 108.
20 Specifically, sensors within thermostat 108 determine if the current temperature within building 101 rises above (in the case of cooling) or falls below (in the case of heating) a temperature set point. If one of these events occurs, thermostat 108 issues a heating or cooling call to controller 102. In response, controller 102 may issue control signals to one or more pieces of HVAC equipment, including indoor unit 104 and outdoor unit 106.

25 In the embodiment of FIG. 1, thermostat 108 performs several functions. First, thermostat 108 senses the temperature within building 101. Second, in response to the temperature within building 101 being above or below a desired set point, thermostat 108 provides a signal to controller 102 calling for cooling or heating, respectively. Once the desired temperature is reached, the heating/cooling call is removed. In certain embodiments, one or more of these
30 functions may be performed by the thermostat or by other components of the HVAC system.

5 Thermostat 108 may also provide signals to enable or disable other optional equipment including, but not limited to, humidifiers and ventilators (not shown). In the embodiment of FIG. 2, for example, a thermostat is not required and the functions described are instead performed by a temperature sensor alone or in combination with a controller.

FIG. 2 is a schematic depiction of a second embodiment of an HVAC system 200 in
10 accordance with this disclosure. HVAC system 200, which is incorporated into building 201, includes an indoor unit 204 and an outdoor unit 206 communicatively coupled to a controller 202. Indoor unit 204 may comprise, but is not limited to, heating equipment such as a furnace. Outdoor unit 206 may comprise, but is not limited to, cooling equipment such as an air conditioner. Other examples of indoor and outdoor units include, but are not limited to, air
15 handlers and heat pumps, respectively. In contrast to the embodiment of FIG. 1 in which controller 102 was incorporated into indoor unit 104, controller 202 is depicted as a standalone unit.

The embodiment of FIG. 2 further includes a temperature sensor 210 for determining the temperature within building 201. In certain embodiments, temperature sensor 210 may be
20 configured to determine one or more of the actual temperature within building 201 or whether the current temperature within building 201 is above or below a temperature set point.

Temperature-based signals and data from temperature sensor 210 may be received and analyzed by controller 202. For example, controller 202 may generate control signals to control HVAC equipment such as indoor unit 204 and outdoor unit 206, based at least in part on the
25 temperature-based signals received from temperature sensor 210. In certain embodiments, sensor 210 may transmit the temperature readings to controller 202. Controller 202 may monitor the temperature readings provided by sensor 210 to determine if the temperature in building 201 exceeds or falls below a temperature set point, thereby causing the controller 202 to generate a heating/cooling call. In response to the heating/cooling call, controller 202 may issue appropriate
30 control signals to at least one of the indoor unit 204 and the outdoor unit 206. In other

5 embodiments, sensor 210 may transmit a signal that the building 201 air temperature is above or below a temperature set point. Controller 202 may then generate a heating/cooling call and issue control signals to control HVAC equipment such as indoor unit 204 and outdoor unit 206 in response to this signal. In certain embodiments, temperature readings from temperature sensor 210 may also be stored in a memory module of the controller 202. Stored temperature readings
10 may be used by the controller 202 to determine temperature trends, response times to control signals, and other metrics to be used in refining a control plan implemented by the controller 202.

 In one or more aspects, the thermostat 108 is configured to accept operational data as user input. The operational data may include, but is not limited to, one or more of a temperature set
15 point, a humidity set point and a target rate of temperature change. The thermostat 108 may include a user interface such as one or more buttons, a touch sensitive display screen or a combination thereof using which a user may input the operational data. In an aspect, the thermostat 108 may be capable of wireless communication using one or more wireless protocols. Such wireless protocols may include, but are not limited to, one or more of Bluetooth, Wi-Fi and
20 Zigbee protocols. In such a case, the thermostat 108 may wirelessly connect to a computing device (e.g., a smart phone) and may receive the operational data from the computing device as input by the user on the computing device. For example, a user may input the operational data on a smartphone using a smartphone application, wherein the operational data may be wirelessly communicated from the smartphone to the thermostat 108. In an aspect, the thermostat 108 may
25 be configured to transmit the operational data including one or more of the temperature set point, humidity set point and target rate of temperature change to one or more equipment of the HVAC system or a controller (e.g., controller 102) configured to control one or more HVAC equipment.

 In one or more aspects, thermostat 108 may include, in addition to temperature sensing, other features such as humidity sensing, occupancy detection, geofencing, and compatibility with
30 remote wireless sensors. In order to provide one or more of these features, the thermostat 108

5 may include additional sensors including, but not limited to, a humidity sensor and an occupancy detection sensor (e.g., a motion sensor). The thermostat 108 may be configured to communicate temperature measurements, humidity measurements and occupancy data collected using the respective sensors to one or more equipment of the HVAC system or a controller (e.g., controller 102) configured to control one or more HVAC equipment.

10 In one or more aspects, the controller 102 may determine a control plan based on the operational data to run one or more equipment of the HVAC system for achieving optimal efficiency of operation and comfort for the user.

In one or more aspects, the HVAC system (e.g., 100 or 200) may include a plurality of thermostats, a plurality of temperature sensors, a plurality of humidity sensors, a plurality of
15 occupancy sensors (e.g., motion sensors) or any combination thereof, wherein one or more of the thermostats and the sensors are capable of wired and/or wireless communication to other devices of the HVAC system including other thermostats, other sensors, HVAC equipment and controller (e.g., controller 102). In an aspect, a thermostat (e.g., thermostat 108) or a temperature sensor (temperature sensor 210) may be placed at each of a plurality of designated areas in a
20 building (e.g., building 101 or 201). For example, a thermostat or temperature sensor may be placed in each room of a residential building. Each of the thermostats and temperature sensors may be capable of wireless communication using one or more wireless protocols and may wirelessly transmit ambient temperature readings to one or more equipment of the HVAC system or a controller (e.g., controller 102) configured to control one or more HVAC equipment.

25 In one aspect, the HVAC system (e.g., HVAC system 100) may have a primary thermostat (e.g., thermostat 108) and a plurality of remote temperature sensors (e.g., temperature sensor 210) in the building, wherein each remote temperature sensor is placed in a different designated area of the building. Each of the remote temperature sensors may wirelessly communicate their respective temperature readings to the primary thermostat. The primary thermostat may collect
30 all the temperature readings from the various remote sensors including its own temperature

5 reading and may transmit the temperature readings to a central controller (e.g., controller 102) using a wired connection or wireless interface. The central controller may determine a control plan based on the temperature readings from the various area of the building, such that one or more equipment of the HVAC system may be operated to avoid hot or cold spots in the building. In an alternative aspect, one or more designated areas of the building may additionally or
10 alternatively include a remote humidity sensor, a remote occupancy detection sensor (e.g., motion sensor), a remote secondary thermostat or a combination thereof. Each of these additional sensors and thermostats may transmit their respective data (e.g., humidity measurements, detected motion, temperature or humidity set points entered in a secondary thermostat) to the primary thermostat for reporting to the central controller. In an alternative aspect, each of the
15 thermostats (including any secondary thermostats) and sensors may transmit their respective data directly to the central controller using a wired connection or a wireless interface.

Additionally or alternatively, one or more of the thermostats and sensors (including temperature sensors, humidity sensors and occupancy sensors) placed in the building may connect to the internet and may upload their data to a cloud service. This data may include, but is
20 not limited to, operational data including temperature set points, humidity set points, target rate of temperature change, ambient temperature reading, ambient humidity readings and occupancy data. In this context, the controller may also connect to the internet and may download the operational data from the same cloud service.

FIG. 3 is a schematic depiction of controller 300 according to an embodiment of this
25 disclosure in which controller 300 is configured to receive signals from a legacy thermostat. As previously noted, controller 300 may be incorporated into an indoor unit, an outdoor unit, or a thermostat or may be part of a standalone component. Controller 300 may include a processing unit 301A and memory module 301B.

Because controller 300 is intended for use with a legacy thermostat, controller 300 includes
30 a terminal block 302 to connect controller 300 to a legacy thermostat. Terminal block 302 may

5 include terminals corresponding to one or more corresponding output terminals of the legacy thermostat. For example, as shown in FIG. 3, terminal block 302 includes a 24VAC supply line terminal (R) 303A, a common ground terminal (C) 303B, a cooling call terminal (Y) 303C, a heating call terminal (W) 303D, a fan terminal (G) 303E, a reversing valve terminal (O) 303F, and a dehumidifier terminal (Dehum) 303G. In other embodiments, one or more of terminals
10 303A–G may be omitted or other terminals may be added. For example, if a thermostat is capable of issuing control signals corresponding to multiple stages of heating or cooling calls (e.g., Y2 or W2 terminals), the controller may include corresponding terminals for receiving such signals.

Controller 300 may also include one or more equipment terminals for communicating with
15 indoor and/or outdoor units. For example, controller 300 may include a RS-485 interface 304 suitable for communicating data and control signals to communicating HVAC equipment. Controller 300 may also include components for controlling non-communicating equipment using other signals, such as 24VAC signals. For example, controller 300 includes a cooling relay 306 and a corresponding cooling terminal block 308 for connecting controller 300 to a non-
20 communicating air-conditioning unit.

Controller 300 may also include interfaces for receiving data or signals from other components of the HVAC system. For example, controller 300 includes sensor interfaces 310A, 310B for receiving data from a return air (R/A) and a supply air (S/A) sensor, respectively. Controller 300 may also include an accessory interface 311 for communicatively coupling other
25 components of the HVAC system, including, but not limited to, indoor air quality equipment, dehumidifiers, humidifiers, ventilators dampers, and other zoning equipment.

Controller 300 may also include a communication module 312 for communicating with a computing device. Communication module 312 may include a wired interface. For example, in certain embodiments, communication module 312 may include, but is not limited to, one or more
30 of a universal serial bus, Ethernet, FireWire, Thunderbolt, RS-232, or similar interface. Instead

5 of or in addition to a wired interface, communication module 312 may include a wireless interface for communicating with a computing device. Such wireless interfaces may include, but are not limited to, Bluetooth, Wi-Fi, and ZigBee interfaces. In certain embodiments, communication module 312 may be configured to connect controller 300 directly to the computing device. Communication module 312 may also be configured to connect controller 300
10 to the computing device over a computer network, including, but not limited to, a local area network (LAN), a wide area network (WAN) and the internet.

Communication module 312 generally permits controller 300 to exchange data with the computing device. In certain embodiments, the data exchanged between the controller 300 and the computing device may include system configuration data. System configuration data may
15 include data regarding the HVAC system in which controller 300 is installed, including information regarding any HVAC equipment or components that are included in the HVAC system. Configuration data may include general information about the basic types of equipment included in an HVAC system, but may also include specific details regarding particular pieces of HVAC equipment. For example, if an HVAC system includes a multi-stage air conditioner, the
20 configuration data may include product details including the brand, model, product number, and serial number of the unit. The configuration data may also include performance details including the number of stages and corresponding capacities of the air conditioner.

Communication module 312 may also be configured to send and/or receive operating parameters. As previously discussed, controller 300 generally operates by developing and
25 executing a control plan to meet heating and cooling calls to reach a desired temperature set point in as close to a target time as possible. During operation, communication module 312 may be used to send or receive operating parameters such as the temperature set point and target time to set or retrieve the operational goals of the HVAC system. In one or more aspects, the operating parameters exchanged between the controller 300 and a computing device may include
30 a target rate of temperature change to be achieved in a building during a cooling operation or a

5 heating operation. The controller 300 may develop and execute a control plan in response to a heating or cooling call to achieve and maintain the target rate of temperature change in the building.

Communication module 312 may also be used to exchange historical performance data with a computing device. For example, controller 300 may store temperature readings received
10 from a temperature sensor of the HVAC system in memory module 301B and transmit or otherwise make the temperature data available to a computing device. Controller 300 may also transmit historical performance data that may be used to assess the general effectiveness of the system and to determine whether maintenance may be required. For example, the controller may provide data regarding the amount of time which a particular piece of HVAC equipment is
15 operated. Such usage information may then be used to determine the likely life of HVAC equipment parts and to develop a corresponding maintenance schedule.

In one or more aspects, the communication module 312 of the controller 300 may be configured to send and/or receive operational data from a plurality of devices including, but not limited to, one or more thermostats, one or more sensors, one or more computing devices, or a
20 combination thereof. The communication module 312 may be configured to exchange the operational data with one or more of these devices using the wired interface or the wireless interface of the communication module 312. The operational data may include, but is not limited to, temperature set points, humidity set points, target rate of temperature change, ambient temperature readings, ambient humidity readings and occupancy data. In one aspect, the
25 communication module 312 may wirelessly exchange data with one or more of these devices using a peer to peer wireless connection, over a local private area network, over the internet or a combination thereof. The controller 300 may determine a control plan based on the operational data received from one or more devices to run one or more equipment of the HVAC system for achieving optimal efficiency of operation of the one or more equipment and/or comfort for the
30 user.

5 In one or more aspects, the communication module 312 may be configured to receive operational data from a plurality of thermostats and/or sensors placed in various designated areas in a building. The sensors may include temperature sensors, humidity sensors, occupancy sensors, or a combination thereof. In an aspect, the controller 300 may be communicatively coupled to a thermostat via the terminal block 302 as well as via the communication module 312 using the wired interface or the wireless interface of the communication module 312. This allows the controller 300 to receive legacy 24 VAC signals from the thermostat while additionally allowing the controller 300 to receive operational data from the thermostat using the communication module 312. This feature of the controller 300 may be particularly useful as most commercially available smart thermostats connect to the HVAC system via legacy 24VAC wiring and are also capable of wireless communication.

 In one or more aspects, the controller 300 may connect to the Internet using the wired interface (e.g., ethernet interface) or the wireless interface (e.g., Wi-Fi interface) of the communication module 312. The controller 300 may be configured to connect to a cloud service over the internet to access and download operational data uploaded to the cloud service by one or more thermostats and/or one or more sensors placed in the building.

 FIG. 4 is a flow chart illustrating an embodiment of a general method for operating an HVAC system in accordance with this disclosure. In one or more embodiments, any one or more of the steps described may not be performed. In other embodiments, any one or more of the steps depicted may be performed in any suitable order or in any combination.

25 The method begins at step 402 with the controller initiating device discovery. Device discovery generally refers to the process of identifying the equipment present in an HVAC system and may include determining one or more of the type, capacity, number of stages, or other characteristics of that equipment.

 Device discovery may occur using several methods alone or in combination and may include reading or retrieving information provided by an installer, customer, or other user. For

5 example, in certain embodiments, the user may configure a series of dip switches located at a controller, a thermostat, a piece of HVAC equipment, or any other suitable location within the HVAC system to indicate the characteristics of one or more pieces of HVAC equipment within the system. During device discovery, a controller or other suitable piece of equipment in the system may read the dip switches to determine the characteristics of installed HVAC equipment.

10 In certain embodiments, device discovery data may be stored in and retrieved from memory. For example, device discovery data may be stored locally in the memory of a controller of the HVAC system. In other embodiments, the device discovery data may be stored in a remote location, for example in a remote server. In either embodiment, the device discovery process may comprise executing instructions to retrieve the device discovery data from the memory,
15 regardless of where the memory is located.

The device discovery data may be stored in memory that is read-only memory. For example, the memory may include device discovery data that is fixed during manufacturing of the HVAC system. In certain embodiments, the read-only memory may store default information corresponding to a default HVAC system and may permit an installer or other user to reset the
20 HVAC system to the default HVAC system if an error, system failure, or other problem is encountered.

In certain embodiments, the memory may be reprogrammable by a user. In such embodiments, the user may be able to input information corresponding to the HVAC system to be stored in memory. Any suitable method may be used to program the memory. For example,
25 the user may use a software application to configure the HVAC system and input device data. Such software may be run on any suitable platform. For example, in certain embodiments, device data may be input using a panel or terminal specifically designed for the HVAC system. In other embodiments, a user may use a computing device having a program or application installed that allows the user to input or modify device data. Such general computing devices may include, but
30 are not limited to, laptops, notebook computers, tablet computers, smartphones, smart watches,

5 netbooks, and desktop computers. Inputting of device data may be done by directly connecting the computing device to the HVAC system using any suitable interface or by remotely providing the device data, including by providing data over a wired or wireless connection. For example, in certain embodiments, a user may input device data by directly connecting a computing device to a piece of equipment in the HVAC system using a wired connection which may include, but is
10 not limited to, one or more of a universal serial bus, Ethernet, FireWire, Thunderbolt, RS-232, or similar interface. In other embodiments, the user may provide device data to the HVAC over the internet or through any suitable wireless technology, including but not limited to Wi-Fi, Bluetooth, and ZigBee.

In certain embodiments, device data may be stored and retrieved from a database. The
15 database may be stored locally in memory connected to the HVAC system or may be remotely accessible from a server or other remote data source. In certain embodiments, device data corresponding to a given piece of HVAC system may be retrieved from the database based on information provided by a user or by components of the HVAC system.

For example, in certain embodiments, information may be provided to a database regarding
20 a particular piece of HVAC equipment to include in an HVAC system. Based on the information, one or more database entries may be returned. For example, if a product name or product ID corresponding to a particular piece of HVAC equipment is provided, device data for the particular product may be returned. Alternatively, if more generic information (e.g., heating or cooling, number of stages, capacity, etc.) is provided, multiple entries may be returned from
25 which a selection or further refinement of the retrieved entries may be made.

Device data may also be reported to the HVAC system by the connected equipment. In certain embodiments, a piece of HVAC equipment may automatically report its device data to the HVAC system when first connected to the HVAC system. The HVAC equipment may also provide its device data in response to a device data request received from other components of
30 the HVAC system.

5 In certain embodiments, device characteristics may also be determined using a trial and error approach. For example, if a cooling command is issued and temperature does not drop, the attached equipment is likely a furnace or other heating equipment. A similar approach may be used to determine if a piece of HVAC equipment is capable of operating at multiple capacities or stages. For example, after determining that a cooling unit is connected, a cooling command may
10 be issued, requesting the HVAC equipment to provide cooling at a first stage and a second stage corresponding to different capacities. If cooling following issuance occurs faster when operating in one stage or the other, the connected HVAC unit is likely a two-stage unit. Conversely, if no change is observed or if cooling does not occur, then the HVAC unit is likely a single-stage unit.

 After discovery has occurred, the controller determines the desired target time 404. Target
15 time may be input directly by a user or installer or may be determined automatically based on user preferences. For example, a user may indicate a preference that the system operates to maximize performance, maximize user comfort, maximize efficiency, or to achieve a preferred balance of performance, comfort, and efficiency. In response, the controller may automatically determine an appropriate target time corresponding to the preferences. For example, if a user
20 prefers performance over efficiency, the controller may apply a short target time such that the HVAC equipment is operated at a relatively high capacity for a shorter period of time. On the other hand, if a user prefers efficiency over performance, the controller may select a longer target time such that the HVAC equipment is operated at a lower capacity for a longer time.

 In certain embodiments, the user may input the desired target temperature directly into a
25 thermostat that is communicatively coupled to the HVAC system controller. In other embodiments, the HVAC system controller may have a means for directly inputting the desired target temperature. In still other embodiments, the user may input the desired target temperature by directly connecting a computing device to the HVAC system using any suitable interface or by remotely providing the device data, including by providing data over a wired or wireless
30 connection. Such general computing devices may include, but are not limited to, laptops,

5 notebook computers, tablet computers, smartphones, smart watches, netbooks, and desktop computers. A suitable wired connection may include, but is not limited to, one or more of a universal serial bus, Ethernet, FireWire, Thunderbolt, RS-232, or similar interface. A suitable wireless may include, but is not limited to Wi-Fi, Bluetooth, and ZigBee.

Once a target time has been determined, the controller develops an initial control plan 406
10 for operating the HVAC equipment to satisfy a heating/cooling call in as close as possible to the target time. Establishing the initial control plan may occur in various ways and may differ depending on whether the equipment to be controlled is staged, and therefore has discrete capacity levels, or modulating, and is therefore capable of a continuous range of capacities.

In certain embodiments in which staged equipment is to be controlled, the initial control
15 plan may be established by determining satisfy times for each of one or more stages. A satisfy time is generally the time required for HVAC equipment operating at a particular stage or capacity to satisfy a heating/cooling call. Based on the satisfy times, the controller may then determine at which stage or stages one or more pieces of HVAC equipment should be operated and approximate the time required to run at each stage(s) in order to satisfy a subsequent
20 heating/cooling call in a time that is as close as possible to the target time.

In certain embodiments, the actual satisfy time for any given stage or capacity setting may be determined by running the equipment at the stage until the heating/cooling call is satisfied. This approach may be repeated for each stage of the HVAC equipment to determine the full range of satisfy times.

25 In certain embodiments, determining satisfy times may comprise determining the satisfy time for a subset of stages and then calculating, estimating, looking up or otherwise determining satisfy times for any remaining stages based on the satisfy times of the subset of stages. For example, the satisfy time for the maximum capacity of a piece of HVAC equipment may be determined as previously described. Once the maximum capacity satisfy time has been
30 determined, the satisfy times of any remaining stages or capacity settings may be calculated,

5 estimated, looked up, or otherwise determined based on the maximum capacity satisfy time. Doing so eliminates the need to run the HVAC equipment at each stage or capacity setting to establish the satisfy times.

In certain embodiments in which satisfy times are determined from a subset of satisfy times, a proportional capacity map may be applied to the known satisfy times in order to
10 determine satisfy times for any remaining stages or capacity settings. One such method of doing so is to apply a proportional capacity map that determines satisfy times based on the relative capacities of stages to the capacities of stages for which an actual satisfy time has been determined. For example, a system having a first, second, and third stage corresponding to 40%, 60% and 100% (i.e., maximum) capacity may first be run at maximum capacity and a
15 corresponding maximum capacity satisfy time of 10 minutes may be achieved. Applying a proportional capacity map based on capacity may then result in estimates for the first and second stage satisfy times of 25 minutes and 17 minutes, respectively.

More sophisticated mappings may also be implemented. For example, instead of, or in addition to, the ratios of stage capacities, the capacity map may be based on a model that takes
20 into account thermodynamic effects, equipment characteristics, room characteristics, or any other factor that may affect the time in which a given piece of HVAC equipment is able to satisfy a heating/cooling call. In certain embodiments, the capacity map may be created based in whole or in part on empirical data, which may include data generated during testing of the HVAC equipment or similar units or data collected during actual operation once installed.

25 Because a low stage may not be able to satisfy the heating/cooling call within a reasonable time, or at all, certain embodiments may include a timeout if a heating/cooling call is not satisfied within a given time. In embodiments implementing a timeout, the process of determining the initial control plan may be abbreviated by not determining the satisfy times for any stages with capacities below that of a timed out stage.

5 Based on the satisfy times, the controller may establish an initial control plan comprising instructions for the HVAC system including, but not limited to, what equipment to operate, at what capacity the equipment should be operated, and for how long. As a result, the initial control plan is a best guess of how to operate the HVAC equipment in order to satisfy a heating/cooling call in as close to the target time as possible.

10 In one embodiment, the initial control plan is established by first determining the minimum stage capable of satisfying the heating/cooling call in less than the target time. Because the minimum satisfying stage will not properly satisfy the heating/cooling call in the target time, the target time may be more closely achieved by running the HVAC equipment at the minimum satisfy time for a first period of time then switching the HVAC equipment to the next higher
15 stage for a second period of time. The length of the first and second periods of time may be based off of the satisfy times of the two stages. For example, if a target time is 10 minutes, a third stage satisfies in 6 minutes, a second stage satisfies in 8 minutes, and a first stage satisfies in 16 minutes, the second stage is the minimum satisfying stage. Accordingly, the second stage and the first stage are used in the initial control plan. Based on these specific numbers, the initial
20 timing would be to operate at the first stage for 2.5 minutes and the second stage for 7.5 minutes.

 After the initial control plan is determined, the controller receives a heating/cooling call at 408. In certain embodiments, the heating/cooling call may be received from a legacy thermostat communicatively coupled with the controller. In other embodiments, the heating/cooling call may be received from a communicating thermostat coupled with the controller. In other
25 embodiments, the heating/cooling call may be generated by the controller itself in response to a temperature signal received by the controller from a communicatively coupled air temperature sensor. In response to the heating/cooling call, the controller runs the HVAC equipment based on the current control plan until the heating/cooling call is satisfied. In certain embodiments, the controller may be programmed to time out if the heating/cooling call is not satisfied within a
30 particular time period. Doing so may avoid situations in which the initial control plan

5 underserves a heating/cooling call such that the heating/cooling call cannot be satisfied in a reasonable time, or at all.

Once the heating/cooling call is satisfied, the controller determines the actual satisfy time using the current control plan at 412. The controller then compares the actual satisfy time to the target time at 414. Based on whether the actual satisfy time is greater than or less than the target
10 time and, in certain embodiments, by what degree the target time and satisfy time differ, the controller updates the control plan at 416. When the controller receives a subsequent heating/cooling call, the controller implements the updated control plan, determines the satisfy time based on the updated control plan, compares the satisfy time under the updated control plan to the target time and updates the control plan again to account for any differences. This process
15 may repeat continuously with the controller updating the control plan after every heating/cooling cycle.

As previously mentioned, the control plan may be updated based on whether the heating/cooling call was satisfied in more or less than the target time and, in certain
20 embodiments, the degree to which the target time was missed. If the heating/cooling call is satisfied in more than the target time, the control plan is adjusted to provide additional heating/cooling accordingly. To do so, the controller may adjust the control plan in various ways, including by changing one or more of the HVAC equipment used in the control plan, the stages or capacities at which a piece of HVAC equipment is run, and the time during which a piece of HVAC equipment is run.

25 As an example, an embodiment of the current disclosure may include a controller communicatively coupled to a two-stage air-conditioner that implements a control plan comprising running the air-conditioner at the first stage for a first period of time and at the second stage for a second period of time. After implementing the control plan, the controller may determine that the time required to satisfy a cooling call is greater than or less than the target
30 time. In response, the controller may adjust the first and second time periods to account for any

5 discrepancies between the actual satisfy time and the target time. For example, if the cooling call was not satisfied within the target time, the control plan may be adjusted to increase the amount of time during which the air-conditioner is run at the second stage.

To the extent the controller is configured to adjust timing, the times for which pieces of HVAC equipment are operated or the times at which HVAC equipment is operated at particular stages or capacities may be adjusted by a fixed amount. For example, the timing may be adjusted
10 by a set number of seconds in favor of the lower stage if the heating/cooling call is satisfied too quickly or the same number of seconds in favor of the higher stage if the heating/cooling call is not satisfied within the target time.

In other embodiments, timing adjustments may be variable. For example, one or more
15 equations may be used to calculate new timing after each heating/cooling cycle. Such equations may adjust the timing based on the degree to which the satisfy time for the more recently completed cycle differs from the target time. An example of such an equation is as follows:

$$\text{New Low Stage Time} = \text{Current Low Stage Time} \times \left(\frac{\text{Target Time}}{\text{Satisfy Time}} \right) \times \text{C.F.}$$

As shown in the equation, the new run time for the low stage is based on the current timing
20 of the low stage and the ratio of the target time to the actual satisfy time for the current cycle. An optional correction factor (C.F.) may also be included in the equation to account for non-linearity and other adjustments to the newly calculated timing.

In certain embodiments, the control plan may be adjusted by changing the capacity at which one or more pieces of HVAC equipment are operated. Adjusting the capacity may
25 comprise changing the stage at which HVAC equipment is operated or, in the case of modulating HVAC equipment capable of operating along a continuum of capacities, changing the operating point of the modulating HVAC equipment. Capacity adjustments may be made in addition to or instead of timing adjustments.

In certain embodiments in which the control plan is adjusted by changing capacities,
30 determining the initial control plan 406 may comprise determining an initial capacity. The initial

5 capacity may be the minimum capacity that will satisfy a heating/cooling call in as close to the target time as possible. Determining the initial capacity may be achieved in various ways. For example, in certain embodiments, the controller may complete multiple heating/cooling cycles at various capacities and determine the actual time required to satisfy the heating/cooling call at each capacity. The capacity with a satisfy time that deviates the least from the target time may
10 then be chosen as the initial capacity.

In other embodiments, the HVAC equipment may be run at a test capacity and the initial capacity for the control plan may be estimated, calculated, or otherwise determined based on the satisfy time of the test capacity. For example, in certain embodiments, the test capacity may be the maximum capacity of the HVAC equipment. Accordingly, if a target time is 20 minutes and
15 the heating/cooling call is satisfied in 15 minutes when operating at maximum capacity, the initial capacity for the control plan may be determined to be 75%.

After the initial capacity is determined, the controller may implement a control plan based on the initial capacity in response to a heating/cooling cycle. Once the heating/cooling call is satisfied, the satisfy time is compared to the target time and the control plan is adjusted. In
20 general, if the satisfy time is less than the target time, the capacity parameters for the control plan are decreased. Conversely, if the satisfy time is more than the target time, the capacity parameters of the control plan are increased. In certain embodiments, this process repeats, continuously adjusting the capacity of the HVAC equipment to hone in on the target time.

In certain embodiments, adjustments to the capacity may occur in fixed increments. For
25 example, the capacity may be adjusted by one of a fixed percentage of the HVAC equipment's total capacity, a fixed amount of volumetric output, and a fixed amount of energy output (e.g., watts or BTU/hr).

In other embodiments, capacity adjustments may be variable. For example, one or more equations may be used to calculate new capacity after every heating/cooling cycle. Such
30 equations may adjust the capacity based on the degree to which the satisfy time of the most

5 recently completed cycle differs from the target time. An example of such an equation is as follows:

$$\text{New Capacity} = \text{Current Capacity} \times \left(\frac{\text{Satisfy Time}}{\text{Target Time}} \right) \times \text{C.F.}$$

As shown in the equation, the new capacity for the subsequent cycle is based on the current capacity and the ratio of the target time to the actual satisfy time for the current cycle. An optional correction factor (C.F.) may also be included in the equation to account for non-linearity and other adjustments to the newly calculated timing.

Notification that a heating/cooling call has been satisfied may occur in various ways depending on the equipment in the system. For example, in systems with legacy thermostats, the notification may correspond to the removal of a cooling or heating request by the thermostat. In systems that include temperature sensors, the notification may be generated in response to a temperature sensor detecting that a temperature set point has been reached. In certain embodiments, the notification may be generated by the temperature sensor. In other embodiments, the controller may generate a notification internally based on temperature readings received from the temperature sensor or sensors. Alternatively, the sensor itself may generate a signal indicating that the temperature set point has been reached.

In certain embodiments, the HVAC system of the present disclosure is not limited to a single sensor. The system may include multiple sensors located throughout a building. In some embodiments, the sensors may be located in the rooms of the building. In still other embodiments, the sensors may be located in the ductwork of the HVAC system itself. It should also be understood that the sensors of the present disclosure are not limited to temperature sensors. The sensors may include, but are not limited to, temperature and humidity sensors. The HVAC system controller may incorporate all information received from these sensors, for example temperature and humidity readings, into the control plan. Furthermore, the information from any of these receivers may be sent to a computing device, as discussed above, for direct monitoring by a user or other system.

5 In certain embodiments, additional inputs or data, such as a temperature set points and real-time temperature readings, may be used to adjust timing or capacity settings of the control plan. Such data may be useful in determining the effectiveness of a particular control plan or in developing a more suitable control plan in fewer cycles than would be required without the additional data. For example, if a sensor provides real-time temperature data, a rate of
10 temperature change associated with particular stages or capacities may be determined. The rate of change may then be used to correct or otherwise refine stage timing or capacity determinations.

 In certain embodiments, the control plan does not require a satisfy time to operate. If the temperature of the building is provided to the controller, then the controller may design a control
15 plan using an algorithm that does not require calculation of a satisfy time. In certain embodiments, the controller may determine an initial control plan based on the temperature inside the building, the HVAC equipment available, and the preferences of the user. The controller may then monitor the temperature inside the building and update the control plan based on the user's desired preferences of performance, comfort, and efficiency.

20 As previously discussed, the control plan is generally established by determining initial control plan parameters, which may include timing and/or capacity settings, and iteratively adjusting the control plan parameters to develop a control plan that satisfies a heating/cooling call in as close to a target time as possible. Because of the iterative process, a controller operating in a relatively steady-state environment and with a consistent target time and
25 temperature set point will generally converge on a particular control plan. In other words, the degree of adjustments required for the timing and capacity settings will eventually diminish as more heating/cooling cycles are performed. However, the environment in which the HVAC system is operating and the operating parameters of the HVAC system may be changed during operation. For example, the environment being controlled by the HVAC system may be subject
30 to changes in temperatures caused by, for example, the opening of a window or door, changes in

5 exterior temperatures, or uses of heat-generating appliances. Operating parameters of the system, such as the desired temperature set point and/or the desired target time, may also be changed.

In general, the previously disclosed approach will adjust for such changes and will converge on a new control plan that accounts for the changed conditions provided that the HVAC equipment is capable of meeting the resulting heating/cooling calls. However, under
10 certain circumstances, such as when changes are particularly sudden or drastic, it may be more efficient for the system to begin from a new initial control plan than to adjust the current control plan over the course of multiple heating/cooling cycles.

In certain embodiments, the control plan may recognize when an unexpected change in performance can be ignored. For example, if a control plan is repeatedly satisfying a cooling call
15 based on a 20 minute target time, and an unexpected event, such as the opening of a door, causes the next cooling call to be satisfied in 10 minutes, then the control plan would recognize that this was not a permanent change to the cooling requirements of the building, and would not adjust the control plan accordingly.

Restarting the control process by determining a new initial control plan may be triggered
20 by various conditions and events. In certain embodiments, for example, the controller may restart from a new initial control plan based on the degree to which the satisfy time or the most recent heating/cooling cycle differs from that of the second-to-last heating/cooling cycle. Large differences in satisfy times for consecutive heating/cooling cycles may indicate that a significant change has occurred in one or more of the controlled environment or the operating parameters.
25 Accordingly, in response to discrepancies in satisfy times, the system may be configured to restart from a new initial control plan.

Restarting from a new initial control plan may also be triggered by a timeout event caused by the currently implemented control plan failing to satisfy a heating/cooling call within a particular time. The timeout may be based on an absolute time, such as a particular number of
30 minutes. The timeout may also be based on a different parameter such as the target time. For

5 example, a timeout may occur if the current control plan fails to satisfy a heating/cooling call within twice the target time.

Implementing a timeout may be particularly useful in multi-stage machines. For example, if a three-stage air-conditioner is operated using its first and second stages only, a sufficient inflow of heat may prevent the air conditioner from satisfying a corresponding cooling call
10 within the target time even if the second stage were to run continuously. To avoid continuously running at the second stage, a timeout may be implemented to stop the current control plan and develop a new initial control plan, which may include operating the air- conditioner at the second and third stages. Alternatively, a timeout may cause the system to increment or decrement the currently operational stages of the equipment without requiring a new initial control plan.

15 Existing HVAC platforms generally rely on an external thermostat to initiate a cooling or heating operation. An HVAC controller (e.g., controller 300) that is configured to control one or more HVAC equipment initiates a cooling or heating operation only when the external thermostat outputs a 24v signal and stops the operation when the external 24v signal is removed. The controller generally does not have access to operational data such as current temperature
20 and/or humidity in the building or set points for temperature and/or humidity. As a result, controllers in existing HVAC systems are mostly limited to initiate and run heating or cooling equipment at fixed capacities based on the 24v on/off signals from the thermostat. Some HVAC controllers are configured to run “runtime learning algorithms” and/or return and supply air temperature feedback based learn algorithms. While control schemes based on both these
25 algorithms can be effective, they cannot account for frequent changes in heating and cooling loads, user defined temperature, dehumidification set points and the like in a real time manner. Furthermore, most commercially available 24v smart thermostats have smart features including, but not limited to, occupancy detection, geofencing and data from remote wireless sensors. Current HVAC controllers have no means for accessing all this information and leveraging it to
30 improve equipment efficiency and user comfort.

5 The HVAC controller 300 described above in accordance with aspects of the present disclosure may be interfaced with a thermostat and/or other sensors (e.g., temperature sensor, humidity sensor, occupancy sensor etc.) and may receive operational data from the thermostat and/or other sensors. This allows the controller 300 to leverage the operational data to and determine control plans to improve equipment efficiency and user comfort.

10 In one or more aspects, when a thermostat is Wi-Fi capable (e.g., smart thermostat), information may be exchanged between the controller 300 and the thermostat over the internet using a cloud application programming interface (API). As described above, the controller may connect to the internet via a wired connection (e.g., ethernet connection) or a wireless interface (e.g., Wi-Fi connection). The thermostat may upload operational data (e.g., sensor information
15 and user settings) to a cloud service over the internet. A link may be established between the controller and a cloud service over the internet and the controller may download the operational data from the cloud service using a cloud API.

 In one or more aspect, the controller 300 and a Wi-Fi capable thermostat may exchange operational data over a local wireless private area Wi-Fi network. Additionally or alternatively,
20 the controller and the thermostat may wirelessly exchange operational data using other wireless interfaces including, but not limited to, Bluetooth and Zigbee interfaces.

 In one or more aspects, the controller 300 may leverage the operational data obtained from the thermostats and other sensors to efficiently operate one or more HVAC equipment and improve user comfort. For example, the controller may track temperature trends of a region in
25 the building and may raise or lower heating/cooling accordingly in real time.

 The controller may track occupancy based on occupancy data recorded by the thermostat or occupancy sensors, and may raise, lower or maintain heating or cooling in occupied areas of a building.

 The controller may make adjustments to capacities at which one or more HVAC
30 equipment operates in response to detecting changes in temperature/humidity set points.

5 The controller may provide better dehumidification support by tracking indoor humidity trends and initiating and adjusting dehumidification as and when needed. The controller may further track an equipment's dehumidification efficiency by monitoring an absolute humidity trend during a dehumidification cycle. Such information can be used by the controller to prioritize dehumidification over cooling and vice-versa as and when needed.

10 The controller may initiate and adjust control plans based on the temperature/humidity set points and current ambient temperature/humidity readings provided by the thermostat.

 Many HVAC installations consist of a thermostat that was improperly located during initial construction. Many old construction and some new construction face issues related to hot and/or cold spots in certain regions of a building. For example, hot and/or cold spots may appear
15 in a living space of a residential building where the thermostat located in a living room cannot account for extreme temperature swings in other rooms. The thermostat in this case heats and cools based on feedback from the living room, while other rooms may be uncomfortably hot or cold. Additionally, in numerous cases, many factors including, but not limited to, close
20 proximity to an outside door, busy hallway and directly overhead air register can cause the thermostat to read unrealistic temperature and humidity. Most commercially available thermostats are required to be hard wired via low voltage 24v thermostat wiring which causes the thermostat to be in a fixed location within a building. This means that new low voltage wiring is required to be installed through the wall of the building in order to relocate the thermostat to a
25 different room or location within the building. Such relocation can be an expensive process that requires professional assistance.

 Aspects of the present disclosure address this problem by allowing a thermostat to wirelessly communicate with HVAC equipment or a controller (e.g., controller 300) configured to control one or more HVAC equipment. As described above, a thermostat capable of wireless communication may exchange operational data with the wireless interface of the controller. This
30 eliminates the need for the thermostat to be connected to the HVAC system via low voltage

5 wiring. As the thermostat does not need to connect to the HVAC system via low voltage wiring, the thermostat may be placed anywhere within the building and relocated as and when needed to avoid hot and cold spots.

In one or more aspect, a plurality of thermostats, a plurality of temperature sensors, a plurality of humidity sensors, a plurality of occupancy sensors (e.g., motion sensors) or any
10 combination thereof may be placed at multiple locations in the building (e.g., each room of a residential building), wherein each of the thermostats and sensors wirelessly communicates operational data to the controller 300 of the HVAC system. Having information relating to current ambient temperature/humidity data and temperature/humidity set points data from multiple regions of a building allows the controller 300 to determine, initiate and adjust a control
15 plan for controlling one or more HVAC equipment in order to avoid hot and cold spots in the building. In an aspect, when there multiple thermostats are placed in a building, a user may designate any one of the thermostats as a primary thermostats. The controller 300 may be configured to initiate and adjust control plans based on operational data received from the designated primary thermostat.

20 Herein, “or” is inclusive and not exclusive, unless expressly indicated otherwise or indicated otherwise by context. Therefore, herein, “A or B” means “A, B, or both,” unless expressly indicated otherwise or indicated otherwise by context. Moreover, “and” is both joint and several, unless expressly indicated otherwise or indicated otherwise by context. Therefore, herein, “A and B” means “A and B, jointly or severally,” unless expressly indicated otherwise or
25 indicated otherwise by context.

The scope of this disclosure encompasses all changes, substitutions, variations, alterations, and modifications to the example embodiments described or illustrated herein that a person having ordinary skill in the art would comprehend. The scope of this disclosure is not limited to the example embodiments described or illustrated herein. Moreover, although this disclosure
30 describes and illustrates respective embodiments herein as including particular components,

5 elements, feature, functions, operations, or steps, any of these embodiments may include any combination or permutation of any of the components, elements, features, functions, operations, or steps described or illustrated anywhere herein that a person having ordinary skill in the art would comprehend. Furthermore, reference in the appended claims to an apparatus or system or a component of an apparatus or system being adapted to, arranged to, capable of, configured to, 10 enabled to, operable to, or operative to perform a particular function encompasses that apparatus, system, component, whether or not it or that particular function is activated, turned on, or unlocked, as long as that apparatus, system, or component is so adapted, arranged, capable, configured, enabled, operable, or operative.

5 WHAT IS CLAIMED IS:

1. A system for controlling an indoor climate of a building, comprising:
one or more equipment associated with a heating ventilation and air-conditioning (HVAC)
system;
a thermostat configured to wirelessly transmit operational data; and
10 a controller communicatively coupled to the one or more equipment and the thermostat;
wherein the controller comprises:
a communication module configured to exchange the operational data with the
thermostat; and
an equipment interface configured to communicate control signals to the one or
15 more equipment to control operation of the one or more equipment;
wherein the controller is configured to:
receive the operational data wirelessly transmitted from the thermostat
using the communication module;
determine based on the operational data a control plan to operate the one or
20 more equipment of the HVAC system; and
operate the one or more equipment of the HVAC system based on the
control plan.
2. The system of Claim 1, wherein the operational data comprises one or more of current
25 ambient temperature in the building, current ambient humidity in the building, occupancy data, a
temperature set point, a humidity set point and a target rate of temperature change.

- 5 3. The system of Claim 1, wherein:
the thermostat is configured to:
wirelessly connect to the internet over a Wi-Fi network; and
upload the operational data to a cloud service over the internet;
the communication module of the controller comprises one or more of:
10 a wired interface capable of connecting the controller to the internet over a wired
connection; and
a wireless interface capable of wirelessly connecting the controller to the internet
over the Wi-Fi network;
the controller is further configured to:
15 connect to the internet using at least one of the wired interface or the wireless
interface; and
download the operational data from the cloud service over the internet.
4. The system of Claim 1, wherein:
20 the communication module of the controller comprises a wireless interface capable of
connecting the controller to a wireless local area network (LAN);
the thermostat is configured to wirelessly connect to the wireless LAN; and
the controller wirelessly receives the operational data from the thermostat over the wireless
LAN.
- 25 5. The system of Claim 1, further comprising:
one or more additional thermostats, wherein each of the one or more additional thermostats
is configured to wirelessly transmit the operational data; and
wherein the controller is configured to receive the operational data from the one or more
30 additional thermostats.
6. The system of Claim 5, wherein the controller is configured to receive an indication that
one of the additional thermostats is a priority thermostat.

35

- 5 7. The system of Claim 1, further comprising:
one or more sensors to record at least a portion of the operational data, wherein the portion
includes one or more of a current ambient temperature, a current ambient humidity and occupancy
in the building, wherein the one or more sensors are configured to wirelessly transmit the
respective portion of the operational data; and
- 10 wherein the controller is configured to receive the portion of the operational data from the
one or more sensors.
8. The system of Claim 1, wherein:
the controller comprises a terminal block communicatively coupled to the thermostat using
- 15 a wired connection;
the controller is configured to receive 24 volts control signals from the thermostat over the
wired connection.
9. The system of Claim 1, wherein:
- 20 the communication module of the controller comprises a wireless interface capable of
wirelessly communicating with one or more computing devices;
the controller is configured to wirelessly receive at least a portion of the operational data
from the one or more computing devices.
- 25 10. The system of Claim 9, wherein the computing device includes at least one of a laptop, a
notebook computer, a tablet computer, a smartphone, a smart watch, a netbook, or a desktop
computer.
11. The system of Claim 1, wherein the one or more equipment comprises at least one of one
30 or more furnaces, one or more air conditioners, one or more air handlers or one or more heat
pumps.

- 5 12. A controller for controlling an indoor climate of a building, comprising:
a communication module configured to exchange operational data with a thermostat
configured to wirelessly transmit the operational data;
an equipment interface configured to communicate control signals to one or more
equipment of a heating ventilation and air-conditioning (HVAC) system to control operation of
10 the one or more equipment; and
a processing unit communicatively coupled to the communication module and the
equipment interface;
wherein the processing unit is configured to:
receive the operational data wirelessly transmitted from the thermostat using the
15 communication module;
determine based on the operational data a control plan to operate the one or more
equipment of the HVAC system; and
operate the one or more equipment of the HVAC system based on the control plan.
- 20 13. The controller of Claim 12, wherein the operational data comprises one or more of current
ambient temperature in the building, current ambient humidity in the building, occupancy data, a
temperature set point, a humidity set point and a target rate of temperature change.
14. The controller of Claim 12, wherein:
25 the communication module of the controller comprises one or more of:
a wired interface capable of connecting the controller to the internet over a wired
connection; and
a wireless interface capable of wirelessly connecting the controller to the internet
over the Wi-Fi network;
30 the processing unit is further configured to:
connect to the internet using at least one of the wired interface or the wireless
interface; and
download the operational data from a cloud service over the internet.

35

- 5 15. The controller of Claim 12, wherein:
the communication module of the controller comprises a wireless interface capable of
connecting the controller to a wireless local area network (LAN); and
the processing unit is configured to wirelessly receive the operational data from the
thermostat over the wireless LAN.
- 10 16. The controller of Claim 12, wherein the processing unit is further configured to receive the
operational data from one or more additional thermostats in the building, wherein each of the one
or more additional thermostats is configured to wirelessly transmit the operational data.
- 15 17. The controller of Claim 16, wherein the processing unit is configured to receive an
indication that one of the additional thermostats is a priority thermostat.
18. The controller of Claim 12, wherein:
the controller comprises a terminal block communicatively coupled to the thermostat using
20 a wired connection;
the controller is configured to receive 24 volts control signals from the thermostat over the
wired connection.
19. A method for controlling an indoor climate of a building, comprising:
25 receiving operational data wirelessly transmitted from a thermostat using a communication
module configured to exchange the operational data with the thermostat;
determining based on the operational data a control plan to operate one or more equipment
of a heating ventilation and air-conditioning (HVAC) system; and
operating the one or more equipment of the HVAC system based on the control plan.
- 30 20. The method of Claim 19, wherein the operational data comprises one or more of current
ambient temperature in the building, current ambient humidity in the building, occupancy data, a
temperature set point, a humidity set point and a target rate of temperature change.

35

5 21. The method of Claim 19, wherein:

the communication module comprises one or more of:

a wired interface capable of connecting to the internet over a wired connection; and

a wireless interface capable of wirelessly connecting to the internet over the Wi-Fi
network;

10 further comprising:

connecting to the internet using at least one of the wired interface or the wireless
interface; and

downloading the operational data from a cloud service over the internet.

15

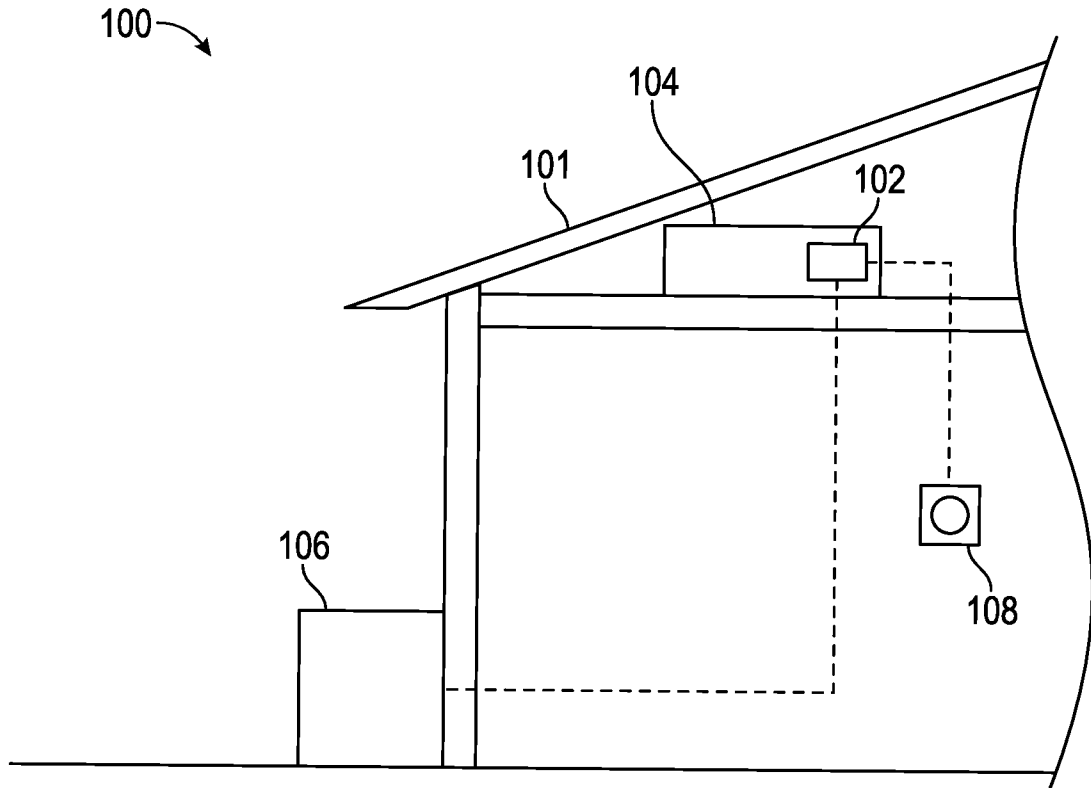

FIG. 1

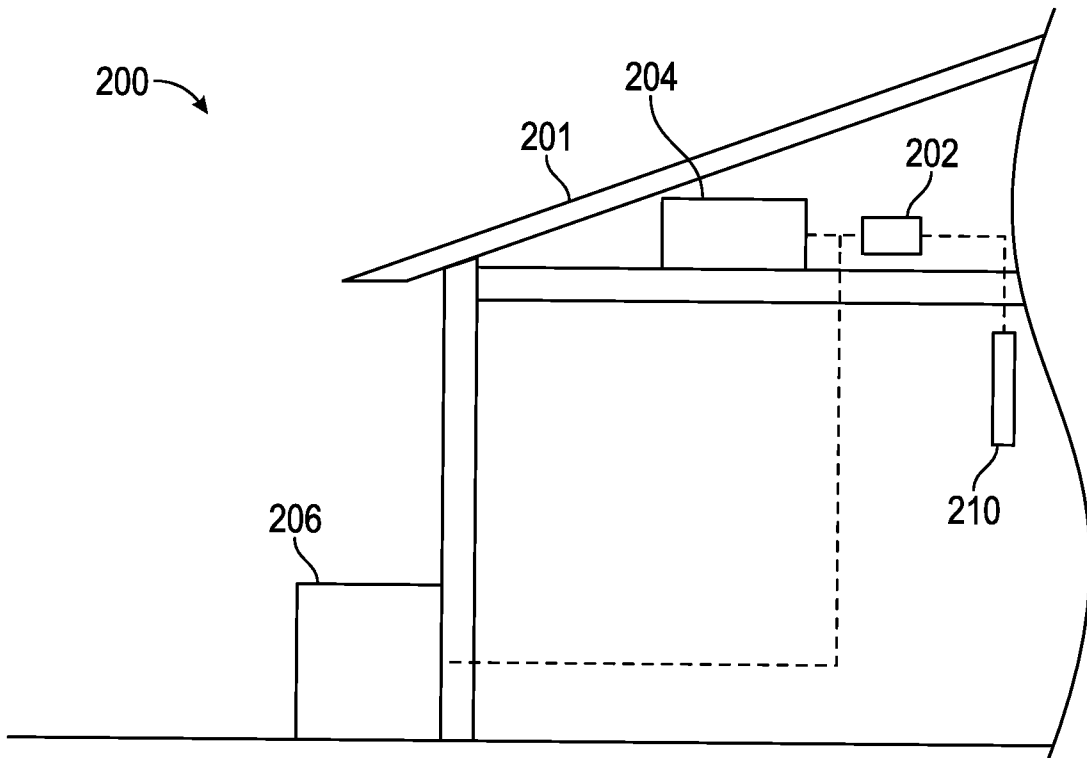

FIG. 2

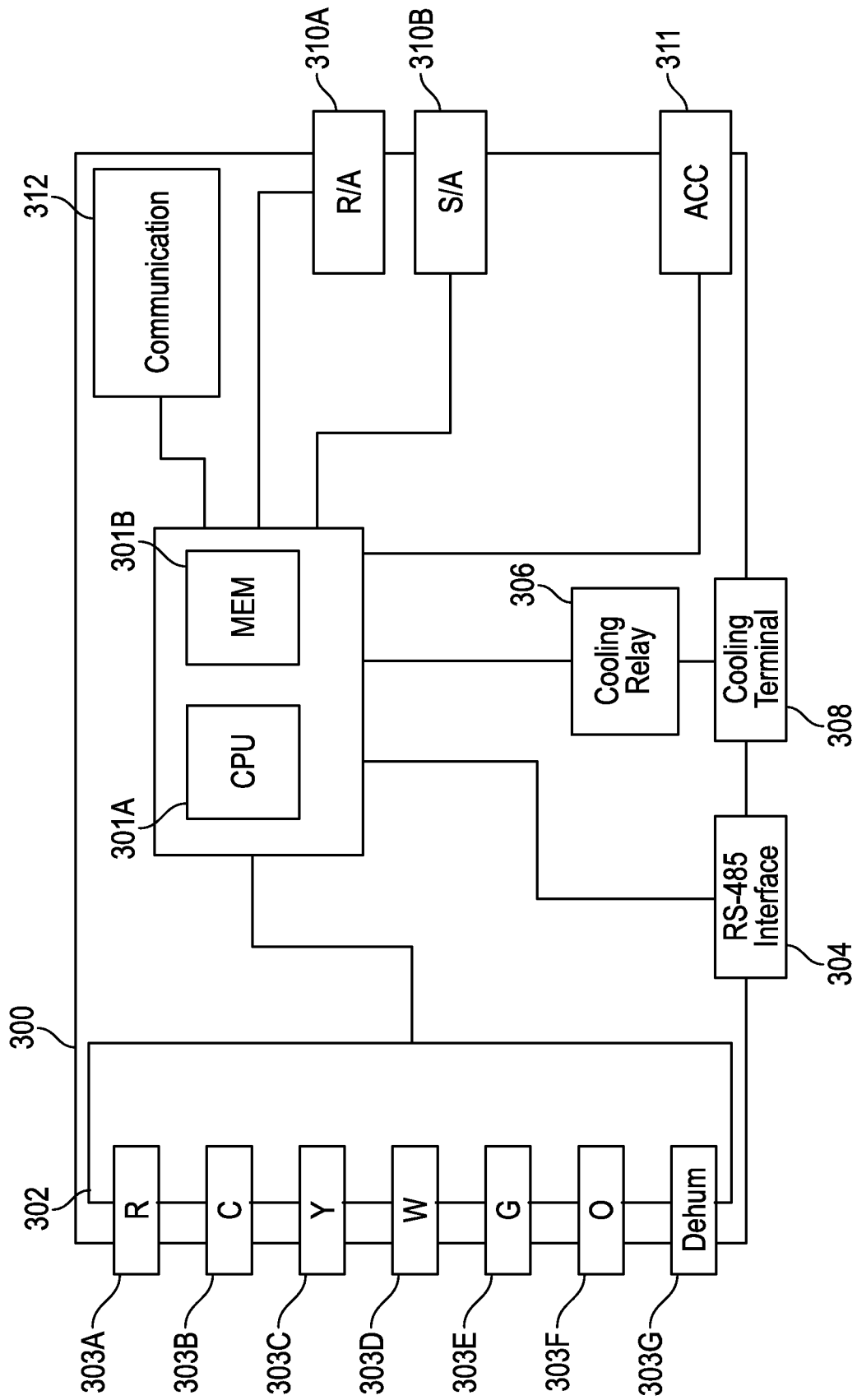

FIG. 3

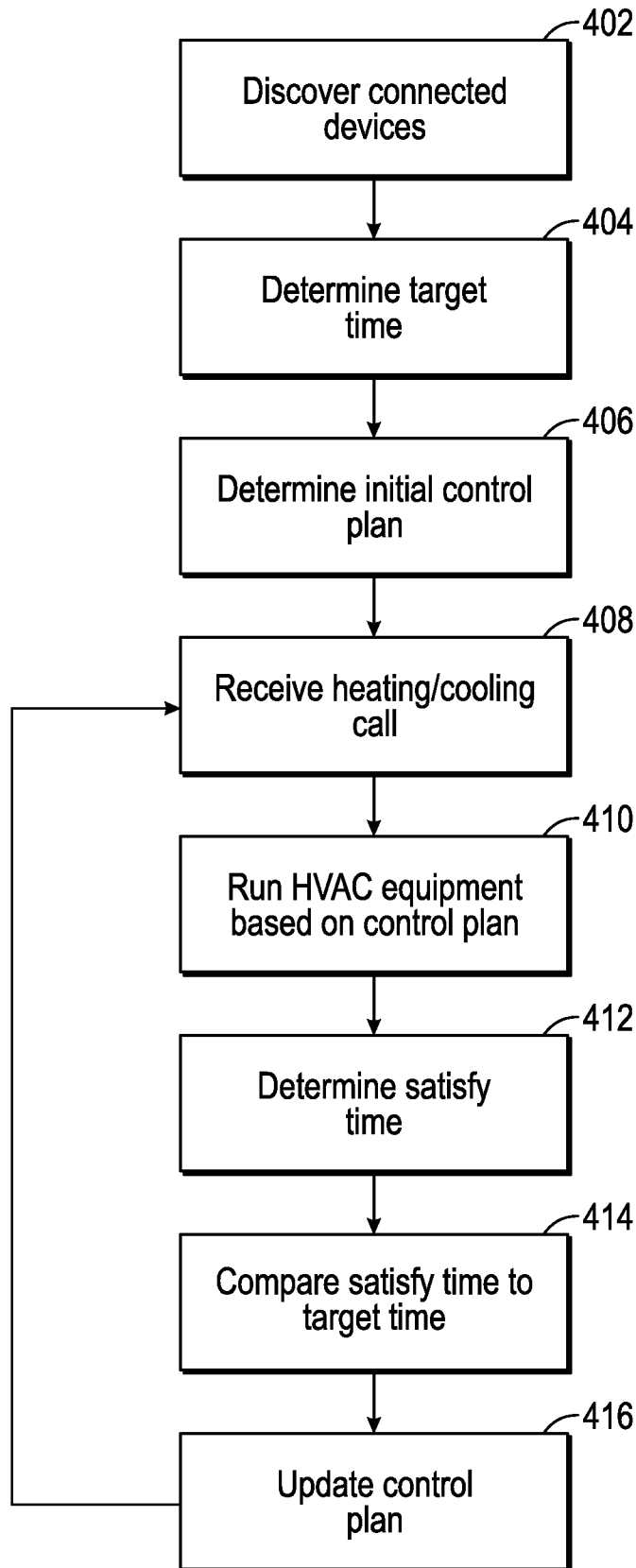

FIG. 4

INTERNATIONAL SEARCH REPORT

International application No.
PCT/US2021/065712

A. CLASSIFICATION OF SUBJECT MATTER F24F 11/30(2018.01)i; F24F 11/61(2018.01)i; F24F 11/62(2018.01)i		
According to International Patent Classification (IPC) or to both national classification and IPC		
B. FIELDS SEARCHED		
Minimum documentation searched (classification system followed by classification symbols) F24F 11/30(2018.01); F24F 11/00(2006.01); F24F 11/62(2018.01); F24F 11/65(2018.01); F24H 9/20(2006.01); G05B 13/02(2006.01); H02J 9/00(2006.01); H04Q 9/00(2006.01)		
Documentation searched other than minimum documentation to the extent that such documents are included in the fields searched Korean utility models and applications for utility models Japanese utility models and applications for utility models		
Electronic data base consulted during the international search (name of data base and, where practicable, search terms used) eKOMPASS(KIPO internal) & Keywords: air conditioning, HVAC, thermostat, controller, communication, control plan, temperature, humidity, wireless, cloud		
C. DOCUMENTS CONSIDERED TO BE RELEVANT		
Category*	Citation of document, with indication, where appropriate, of the relevant passages	Relevant to claim No.
X	US 2019-0338978 A1 (LENNOX INDUSTRIES INC.) 07 November 2019 (2019-11-07) paragraphs [0017], [0020]-[0022], [0026], claims 1, 9, and figure 1	1-21
A	US 2007-0267508 A1 (HOGLUND et al.) 22 November 2007 (2007-11-22) paragraphs [0049]-[0053] and figure 8	1-21
A	CN 101737899 B (ZHEJIANG UNIVERSITY) 02 May 2012 (2012-05-02) claim 1 and figure 1	1-21
A	KR 10-1986753 B1 (DASAN GLOBAL NEWTECH GROUP CO., LTD.) 10 June 2019 (2019-06-10) paragraphs [0015]-[0034] and figure 1	1-21
A	KR 10-2017-0073175 A (NANO-KEM CO., LTD.) 28 June 2017 (2017-06-28) paragraphs [0025]-[0033] and figure 2	1-21
<input checked="" type="checkbox"/> Further documents are listed in the continuation of Box C. <input checked="" type="checkbox"/> See patent family annex.		
* Special categories of cited documents: "A" document defining the general state of the art which is not considered to be of particular relevance "D" document cited by the applicant in the international application "E" earlier application or patent but published on or after the international filing date "L" document which may throw doubts on priority claim(s) or which is cited to establish the publication date of another citation or other special reason (as specified) "O" document referring to an oral disclosure, use, exhibition or other means "P" document published prior to the international filing date but later than the priority date claimed "T" later document published after the international filing date or priority date and not in conflict with the application but cited to understand the principle or theory underlying the invention "X" document of particular relevance; the claimed invention cannot be considered novel or cannot be considered to involve an inventive step when the document is taken alone "Y" document of particular relevance; the claimed invention cannot be considered to involve an inventive step when the document is combined with one or more other such documents, such combination being obvious to a person skilled in the art "&" document member of the same patent family		
Date of the actual completion of the international search 28 April 2022		Date of mailing of the international search report 28 April 2022
Name and mailing address of the ISA/KR Korean Intellectual Property Office 189 Cheongsu-ro, Seo-gu, Daejeon 35208, Republic of Korea Facsimile No. +82-42-481-8578		Authorized officer HWANG, Chan Yoon Telephone No. +82-42-481-3347

INTERNATIONAL SEARCH REPORT

International application No.

PCT/US2021/065712

C. DOCUMENTS CONSIDERED TO BE RELEVANT

Category*	Citation of document, with indication, where appropriate, of the relevant passages	Relevant to claim No.
PX	US 2021-0123623 A1 (GOODMAN MANUFACTURING COMPANY L.P.) 29 April 2021 (2021-04-29) claims 1-21 and figures 1-4 The above document is a publication of the earlier application whose priority has been claimed in this international application.	1-21

INTERNATIONAL SEARCH REPORT
Information on patent family members

International application No. PCT/US2021/065712

Patent document cited in search report			Publication date (day/month/year)	Patent family member(s)			Publication date (day/month/year)
US	2019-0338978	A1	07 November 2019	CA	3040117	A1	01 November 2019
				US	10612808	B2	07 April 2020
US	2007-0267508	A1	22 November 2007	US	7644869	B2	12 January 2010
CN	101737899	B	02 May 2012	CN	101737899	A	16 June 2010
KR	10-1986753	B1	10 June 2019	KR	10-2019-0033098	A	29 March 2019
				WO	2019-059514	A1	28 March 2019
KR	10-2017-0073175	A	28 June 2017	None			
US	2021-0123623	A1	29 April 2021	None			