

(19) World Intellectual Property Organization
International Bureau



(43) International Publication Date
11 January 2007 (11.01.2007)

PCT

(10) International Publication Number
WO 2007/005800 A1

(51) International Patent Classification:
A61F 2/06 (2006.01) B21J 15/02 (2006.01)

(74) Agents: HULSEBERG, Daniel, J. et al.; BAKER BOTTS
L.L.P., 30 Rockefeller Plaza, New York, NY 10112-4498
(US).

(21) International Application Number:
PCT/US2006/025926

(81) Designated States (unless otherwise indicated, for every
kind of national protection available): AE, AG, AL, AM,
AT, AU, AZ, BA, BB, BG, BR, BW, BY, BZ, CA, CH, CN,
CO, CR, CU, CZ, DE, DK, DM, DZ, EC, EE, EG, ES, FI,
GB, GD, GE, GH, GM, HN, HR, HU, ID, IL, IN, IS, JP,
KE, KG, KM, KN, KP, KR, KZ, LA, LC, LK, LR, LS, LT,
LU, LV, LY, MA, MD, MG, MK, MN, MW, MX, MZ, NA,
NG, NI, NO, NZ, OM, PG, PH, PL, PT, RO, RS, RU, SC,
SD, SE, SG, SK, SL, SM, SY, TJ, TM, TN, TR, TT, TZ,
UA, UG, US, UZ, VC, VN, ZA, ZM, ZW.

(22) International Filing Date: 30 June 2006 (30.06.2006)

(25) Filing Language: English

(26) Publication Language: English

(30) Priority Data:
60/695,499 30 June 2005 (30.06.2005) US
11/228,621 16 September 2005 (16.09.2005) US

(84) Designated States (unless otherwise indicated, for every
kind of regional protection available): ARIPO (BW, GH,
GM, KE, LS, MW, MZ, NA, SD, SL, SZ, TZ, UG, ZM,
ZW), Eurasian (AM, AZ, BY, KG, KZ, MD, RU, TJ, TM),
European (AT, BE, BG, CH, CY, CZ, DE, DK, EE, ES, FI,
FR, GB, GR, HU, IE, IS, IT, LT, LU, LV, MC, NL, PL, PT,
RO, SE, SI, SK, TR), OAPI (BF, BJ, CF, CG, CI, CM, GA,
GN, GQ, GW, ML, MR, NE, SN, TD, TG).

(71) Applicant (for all designated States except US): AB-
BOTT LABORATORIES [US/US]; Abbott Vascular
Devices, 400 Saginaw Drive, Redwood City, CA 94063
(US).

(71) Applicants and

(72) Inventors: YOUNG, Eugene [US/US]; 4765 Randi
Court, Union City, CA 94587 (US). RUSS, Borg
[US/US]; 966 Crockett Avenue, Campbell, CA 95008
(US). TRASK, David [US/US]; 1267 Windson Way,
Redwood City, CA 94061 (US). YRIBARREN, Travis,
Richard [US/US]; 250 N. San Mateo Drive, Apt. 311,
San Mateo, CA 94401 (US). ELL, Erik [US/US]; 1225
Nadina Street, San Mateo, CA 94402 (US).

Published:
— with international search report
— before the expiration of the time limit for amending the
claims and to be republished in the event of receipt of
amendments

For two-letter codes and other abbreviations, refer to the "Guid-
ance Notes on Codes and Abbreviations" appearing at the begin-
ning of each regular issue of the PCT Gazette.

(54) Title: ENDOPROSTHESIS HAVING FOOT EXTENSIONS

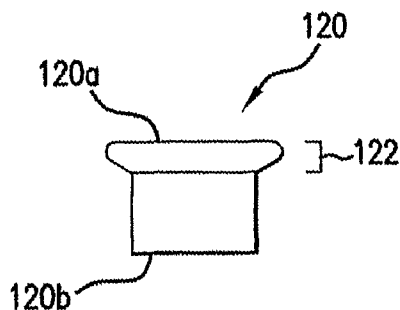

(57) Abstract: Endoprosthesis, such as a stent, including at least one annular element, which further includes a foot extension extending between at least one pair of circumferentially-adjacent strut members defined in the annular member. The foot extension has first and second foot portions extending circumferentially from corresponding ends of the circumferentially-adjacent strut members, and are contoured to provide at least two areas of flexure. A plurality of annular elements are longitudinally aligned and connected at connection locations with connectors, wherein at least one of the connectors is constructed of a bio-absorbable material. A method of inserting a radiopaque marker having a first head on a first end of an endoprosthesis having at least one eyelet comprising: a) disposing said marker element within the eyelet. b) forming a second head on a second end of the marker element, said second head projecting above a second surface of the endoprosthesis.

WO 2007/005800 A1

ENDOPROSTHESIS HAVING FOOT EXTENSIONS

The present application is a continuation-in-part of Application Serial No. 11/228,621 which is a continuation-in-part of Application Serial No. 10/992,976
5 which is a continuation-in-part of Application Serial No. 10/430,644, the entireties of which are hereby incorporated by reference. The present application claims priority to US Provisional Application Serial No. 60/659,499 filed June 30,2005 the entirety of which is hereby incorporated by reference.

10

FIELD OF THE INVENTION

The present invention relates to a method of manufacturing an endoprosthesis for delivery and deployment within a body vessel of a human or animal. More particularly, the invention relates to a stent including at least one annular element having one or more foot extensions for improved performance
15 characteristics and at least one radiopaque marker feature disposed in a portion of the endoprosthesis.

BACKGROUND OF THE INVENTION

Stents, grafts and a variety of other endoprostheses are well known and
20 used in interventional procedures, such as for treating aneurysms, for lining or repairing vessel walls, for filtering or controlling fluid flow, and for expanding or scaffolding occluded or collapsed vessels. Such endoprostheses can be delivered and used in virtually any accessible body lumen of a human or animal, and can be deployed by any of a variety of recognized means. One recognized indication of
25 endoprostheses, such as stents, is for the treatment of atherosclerotic stenosis in blood vessels. For example, after a patient undergoes a percutaneous transluminal coronary angioplasty or similar interventional procedure, an endoprosthesis, such as a stent, is often deployed at the treatment site to improve the results of the medical procedure and to reduce the likelihood of restenosis. The endoprosthesis is configured to
30 scaffold or support the treated blood vessel; if desired, the endoprosthesis can also be loaded with beneficial agent so as to act as a delivery platform to reduce restenosis or the like.

The endoprosthesis is typically delivered by a catheter delivery system to a desired location or deployment site inside a body lumen of a vessel or other

tubular organ. To facilitate such delivery, the endoprosthesis must be capable of having a particularly small cross profile to access deployment sites within small diameter vessels. Additionally, the intended deployment site may be difficult to access by a physician and often involves traversing the delivery system through the tortuous pathway of the anatomy. It therefore is desirable to provide the endoprosthesis with a sufficient degree of longitudinal flexibility during delivery to allow advancement through the anatomy to the deployed site.

Generally endoprosthesis' are constructed of multiple rings that are connected either through a connection section or a connection element, wherein the number of connection sections or elements as well as the thickness of the struts that comprise the rings control the flexibility of the endoprosthesis. Although it is not specifically known how much vessel restenosis can be attributed to stent rigidity, it is known that a reasonably stiff stent may injure the vessel during motion (i.e. pulsatile heart movement). Therefore, it is desirable to produce an endoprosthesis, which has good stiffness properties for deployment within a vessel and wherein the stiffness properties of the endoprosthesis can be changed after deployment within a vessel.

Once deployed, the endoprosthesis should be capable of satisfying a variety of performance characteristics. The endoprosthesis should have sufficient rigidity or outer bias when deployed to perform its intended function, such as opening a lumen or supporting a vessel wall. Similarly, the endoprosthesis should have suitable flexibility along its length when deployed so as not to kink or straighten when deployed in a curved vessel. It also may be desirable to vary the rigidity or flexibility of the endoprosthesis along its length, depending upon the intended use. Additionally, it may be desirable for the endoprosthesis to provide substantially uniform or otherwise controlled coverage, e.g., as determined by the ratio of the outer surface of the endoprosthesis to the total surface of the vessel wall along a given length. For example, increased coverage may be desired for increased scaffolding, whereas decreased coverage may be desired for side access to branch vessels. Control of the cross profile and length of the endoprosthesis upon deployment also is desirable, at least for certain indications.

Numerous designs and constructions of various endoprosthesis embodiments have been developed to address one or more of the performance characteristics summarized above. For example, a variety of stent designs are disclosed in the following patents: U.S. Patent No. 4,580,568 to Gianturco; U.S.

Patent No. 5,102,417 to Palmaz; U.S. Patent No. 5,104,404 to Wolff; U.S. Patent No. 5,133,732 to Wiktor; U.S. Patent No. 5,292,331 to Boneau; U.S. Patent No. 5,514,154 to Lau et al.; U.S. Patent No. 5,569,295 to Lam; U.S. Patent No. 5,707,386 to Schnepf-Pesch et al.; U.S. Patent 5,733,303 to Israel et al.; U.S. Patent No. 5,755,771
5 to Penn et al.; U.S. Patent No. 5,776,161 to Globberman; U.S. Patent No. 5,895,406 to Gray et al.; U.S. Patent No. 6,033,434 to Borghi; U.S. Patent No. 6,099,561 to Alt; U.S. Patent No. 6,106,548 to Roubin et al.; U.S. Patent No. 6,113,627 to Jang; U.S. Patent No. 6,132,460 to Thompson; and U.S. Patent No. 6,331,189 to Wolinsky; each of which is incorporated herein by reference.

10 An additional problem with existing endoprosthesis designs is the difficulty in properly placing the endoprosthesis within a vessel prior to deployment of the endoprosthesis. Current endoprosthesis designs have thinner struts that utilize less radiopaque material and therefore do not appear as well under fluoroscopy. An attempt to address the reduced radiopacity is to include at least one marker band
15 disposed on the delivery device, wherein the marker band may be utilized to indicate an end of the endoprosthesis device or any length there along. Other methods of increasing the radiopacity of an endoprosthesis include the addition of radiopaque markers either disposed upon a surface of the endoprosthesis or within a retaining member associated with endoprosthesis. A shortcoming of present designs is that
20 many are very difficult to manufacture and therefore lead to increased costs. Also, due to size limitations of the radiopaque material used, the markers do not provide sufficient visibility for precise placement.

Another limitation of current endoprosthesis designs is their unsuitability for materials with high elastic limits such as bioabsorbable polymers.
25 The expansion of endoprosthesis devices such as stents generally relies on the plastic deformation of the stent material and typical stent designs do not undergo enough strain during expansion to plastically deform bioabsorbable polymers. This can result in excessive recoil of the stent and sub-optimal apposition of the stent against the vessel wall. Therefore, it is also desirable to provide a stent design that enables
30 expansion of the stent to a greater diameter without plastically deforming the stent material.

Although the various designs for endoprostheses that have been developed to date may address one or more of the desired performance characteristics, there a remains need for a more versatile design for an endoprosthesis that allows

improvement of one or more performance characteristics without sacrificing the remaining characteristics.

SUMMARY OF THE INVENTION

5 The purpose and advantages of the present invention will be set forth in and are apparent from the description that follows, as well as will be learned by practice of the invention. Additional advantages of the invention will be realized and attained by the methods and devices particularly pointed out in the written description and claims hereof, as well as from the appended drawings.

10 To achieve these and other advantages in accordance with the purpose of the invention, as embodied herein and broadly described, the invention includes an endoprosthesis for delivery and deployment in a body lumen. The endoprosthesis includes at least one annular element defined by a first set of interconnected strut members, wherein each strut member has a first end and a second end. Preferably, the
15 first end of selected circumferentially-adjacent strut members are interconnected to define apices proximate a first longitudinal side of the first annular element and the second end of selected circumferentially-adjacent strut members are interconnected to define apices proximate a second longitudinal side of the first annular element. The annular element further includes a foot extension extending between a pair of
20 circumferentially adjacent strut members. The foot extension has a first foot portion extending circumferentially from the first end of one of the circumferentially adjacent strut members of the pair and a second foot portion extending circumferentially from the first end of the other of the circumferentially-adjacent strut members. The first and second foot portions are joined at a toe portion of the foot extension, and
25 generally define an apex between the pair of circumferentially adjacent strut members.

 Preferably, the endoprosthesis of the invention further includes a second annular element defined by a second set of interconnected strut members, wherein each strut member of the second annular element also has a first end and a
30 second end. Circumferentially adjacent strut members are interconnected to define apices on opposite sides of the second annular element. The first annular element and the second annular element are aligned longitudinally adjacent to each other along a longitudinal axis and connected to each other at least one connection location. The

second annular element also can include a foot extension. Additional annular elements also can be provided.

The annular elements are generally expandable between a delivery configuration and a deployed configuration. Each annular element can be defined as a continuous closed ring, or as a coiled sheet or the like. Preferably, each strut member is a straight member, aligned to be substantially parallel with the longitudinal axis of the endoprosthesis when in the delivery configuration. Selected strut members can have a uniform width or can have varied width, such as a continuous taper or increased midsection width between the opposite ends of the strut member.

Alternatively, selected strut members may include generally opposed projections that undergo relative motion during stent expansion, but that interfere with each other following expansion, thereby preventing recoil of the expanded stent to a significantly lower diameter. The apices on either side of each annular element that are not defined by a foot extension can have a V-shape, an arcuate shape, or another shape as desired.

For example, the apices may have an arcuate structure with at least two segments, wherein the area defined between the segments increases during stent expansion and whereby the arcuate structure is modified to support the strut members in a second stable position.

The foot extension is contoured to provide at least two areas of flexure, and extends circumferentially at an angle relative to the longitudinal axis of the annular element. The foot extension can include straight portions, curved portions or combinations thereof to define an ankle portion, a toe portion, a base portion and a heel portion. The base portion can be a straight member, or contoured as a V-shape or the like. In a preferred embodiment, the foot extension has an average width greater than that of the remaining strut members of the annular element. With the foot extension located between longitudinally adjacent annular elements, the base portion of the foot extension generally faces the longitudinally adjacent annular element.

Preferably, the connection location between the longitudinally adjacent annular elements includes the foot extension. By providing the connection location at the base portion of the foot extension, the apices proximate a side of the first annular element generally can be arranged circumferentially out of alignment, or less than 180 degrees out of phase, with the apices proximate a facing side of the second annular element. The connection location can be defined by an overlapping pattern between the longitudinally adjacent annular elements, such as the base of a foot extension on

one annular element and a corresponding apex on the other annular element.

Alternatively, the connection location can include a connector extending between the annular elements. The connector can be a straight member or a shaped member, with opposites ends circumferentially either in or out of alignment, as desired. In a preferred embodiment, the connector has an L-shape, with one leg longer than the other leg. It is further contemplated that the connector may be partially or fully constructed of a bioabsorbable material, wherein after deployment within a vessel, the bioabsorbable component of the connector is absorbed thereby changing the stiffness of the endoprosthesis. In a preferred embodiment, a plurality of connection locations are provided between the adjacent annular elements, with a foot extension provided at some or all of the connection locations. The plurality of foot extensions can all extend in the same circumferential direction, or can be arranged to extend in opposing circumferential directions.

A radiopaque material preferably is incorporated in at least a portion of the endoprosthesis. For example, at least one of the annular elements can comprise radiopaque material. Alternatively, radiopaque markers can be attached to at least one of the annular elements, or the annular elements can be formed of radiopaque material. As another example, at least one of the annular elements can be formed with a first layer of base material and a second layer of radiopaque material.

In accordance with the present invention there is provided an endoprosthesis device for delivery in a body lumen, comprising a thin-walled, generally tubular member having open ends with a first diameter and a second diameter; and at least one marker element connected to at least one end of the thin-walled generally tubular member, the at least one marker comprising a marker housing and a rivet, the rivet extending generally beyond an outer surface and an inner surface of the substantially tubular member.

In accordance with the present invention there is provided a method of manufacturing an endoprosthesis device, comprising the steps of (a) forming an endoprosthesis for delivery in a body lumen (b) smoothing surfaces of the endoprosthesis by media blasting (c) polishing the surfaces of the endoprosthesis with an electropolishing process (d) disposing a radiopaque marker within an opening formed within a structure of an endoprosthesis device (e) applying a force to said marker, thereby forming two heads on the marker, wherein each of the heads extends beyond and inner and an outer surface of the endoprosthesis device. The method may

further include the step of passivation, either prior to placing the marker within the opening or after placement or any combination thereof.

It is to be understood that both the foregoing general description and the following detailed description are exemplary and are intended to provide further explanation of the invention claimed.

The accompanying drawings, which are incorporated in and constitute part of this specification, are included to illustrate and provide further understanding of the device of the invention. Together with the description, the drawings serve to explain the principles of the invention.

10

BRIEF DESCRIPTION OF THE DRAWINGS

Fig. 1a shows a representative embodiment, in planar format, of an endoprosthesis in accordance with the invention.

Fig. 1b illustrates an exemplary embodiment of a connector in accordance with the present invention.

Figs. 2a through 2k show detail views, in planar format, of various exemplary foot extensions in accordance with the present invention.

Figs. 3 through 9 show representative embodiments of the present invention in planar format, each of an endoprosthesis having annular elements connected at a plurality of connection locations without connectors.

Figs. 10 and 11 illustrate alternative embodiments of the present invention, wherein a marker housing and a marker are shown to be associated with the endoprosthesis.

Fig. 12 is an exemplary embodiment of a marker having a pre-formed first head formed thereon in accordance with the process according to the present invention.

Fig. 13 is a side view of an eyelet of an endoprosthesis having a marker disposed therein in accordance with the process of the present invention.

Fig. 14 is a side view of a fixture for forming markers within eyelets in accordance with the present invention.

Fig. 15 is an end view of a portion of the marker forming fixture of Fig. 14.

Fig. 16 is a top view of a portion of the marker forming fixture of Fig. 14.

Fig. 17 is an isometric view of a holding fixture for inserting radiopaque markers into an endoprosthesis.

Fig. 18 is a top view of a portion of the holding fixture illustrating the holding jaws in an open position.

5 Fig. 19 is a top view of a portion of the holding fixture illustrating the holding jaws in a closed position.

Figs. 20 and 21a through 21d are detail views, in planar format, showing various embodiments of overlapping patterns of adjacent annular elements defining connection locations.

10 Fig. 22 shows a representative embodiment, in planar format, of an endoprosthesis configured to have varied characteristics along its length.

Figs. 23a through 23f respectively show a preferred embodiment of a self-expanding stent in accordance with the present invention, (a) in planar format, (b) in a front-half side view as cut and polished from a tube, (c) in a front-half side view of a delivery configuration, (d) in a front-half side view of a deployed configuration, (e) in a perspective view of a deployed configuration, and (f) in a side view as deployed in a curved vessel.

15 Figs. 24a through 24f respectively show a preferred embodiment of a balloon expandable stent in accordance with the present invention, (a) in planar format, (b) in a front-half side view as cut and polished from a tube, (c) in a front-half side view of a delivery configuration, (d) in a front-half side view of a deployed configuration, (e) in a perspective view of a deployed configuration, and (f) in a side view as deployed in a curved vessel.

25 **DETAILED DESCRIPTION OF THE PREFERRED EMBODIMENTS**

In accordance with the present invention, an endoprosthesis is provided for delivery within a body lumen of a human or animal. The endoprosthesis can include, but is not limited to, stents, grafts, valves, occlusive devices, trocars, aneurysm treatment devices, or the like. The endoprosthesis of the present invention can be configured for a variety of intraluminal applications, including vascular, coronary, biliary, esophageal, urological, gastrointestinal or the like.

30 Generally, the endoprosthesis of the present invention includes a first set of interconnected strut members defining a first annular element, wherein each strut member of the first annular element include a first end and a second end. The

endoprosthesis also includes a foot extension extending between a pair of circumferentially adjacent strut members. As described further below, the foot extension has a first foot portion extending circumferentially from the first end of one of the circumferentially-adjacent strut members and a second foot portion extending circumferentially from the first end of the other of the circumferentially-adjacent strut members. The first and second foot portions are joined at a toe portion of the foot extension.

Preferably, and as embodied herein, the endoprosthesis further includes at least a second set of interconnected strut members defining a second annular element. The endoprosthesis can include additional annular elements defined by interconnected strut members as desired or needed. Each annular element generally defines a structure extending circumferentially about a longitudinal axis. The cross profile of each annular element preferably is at least arcuate, and more preferably either circular or spiral, although alternative cross profiles, such as rectilinear or the like, can be used if desired.

The first annular element is aligned longitudinally adjacent to the second annular element along the longitudinal axis, and connected to each other at at least one connection location. Preferably, the first and second annular elements generally define a tubular structure. For example, each annular element can define a continuous closed ring such that the longitudinally aligned annular elements form a closed tubular structure having a central longitudinal axis. Alternatively, each annular element can define an open ring such that a rolled sheet or open tubular type structure is defined by the annular elements. Furthermore, each annular element can define a 360-degree turn of a helical pattern, such that the end of one annular element can be joined with the corresponding end of a longitudinally adjacent annular element to define a continuous helical pattern along the length of the endoprosthesis.

Each strut member of the annular elements includes a first end and a second end. The strut members of each annular element are disposed circumferentially adjacent to each other, and interconnected so as to define an expandable structure. For example, and with reference to the closed tubular structure above, circumferentially-adjacent strut members of each annular element can be interconnected, either directly or indirectly, in an end-to-end format to define a continuous ring having a generally circular cross profile. By altering the angle or distance defined between circumferentially adjacent strut members, the tubular

structure can be radially expanded between a delivery configuration and a deployed configuration. As discussed in detail below, the expandable structure can be expanded by the application of an external force, such as by a balloon, or by a change in delivery conditions, such as an increase in temperature or the removal of a restraint, so as to allow the structure to self expand.

With reference to Fig. 1a, for purpose of illustration and not limitation, a representative embodiment of an endoprosthesis 100 of the present invention in a deployed configuration is depicted in a planar format for clarity. As shown in Fig. 1a, the endoprosthesis includes a plurality of annular elements 10 aligned longitudinally adjacent to each other along a longitudinal axis 15. Although only one annular element need be provided in accordance with the invention, it is preferable that the endoprosthesis includes a plurality of annular elements 10, depicted herein for purpose of illustration by at least a first annular element 10' and a second annular element 10".

Each annular element includes a set of interconnected strut members 20, which are disposed circumferentially about longitudinal axis 15. Each strut member has a first end 22' and a second end 22", referenced generally as end 22. The first end 22' of selected circumferentially-adjacent strut members 20 are interconnected to define apices 30 proximate a first longitudinal side 12 of each annular element 10, and the second end 22" of selected circumferentially-adjacent strut members 20 are interconnected to define apices 30 proximate a second longitudinal side 14 of the annular element. In this manner, each annular element 10 can be expanded to a deployed configuration as shown in Fig. 1a by altering or "opening" the angle defined between circumferentially-adjacent strut members 20. It also is recognized in the embodiment of Fig. 1a that circumferentially-adjacent apices 30 on each side 12, 14 of the annular element 10 are spaced apart by a circumferential distance D, such that each annular element is expanded by increasing the distance D between circumferentially-adjacent apices 30. At any given condition between the delivery configuration and the deployed configuration, the distance D can be balanced or constant from one set of circumferentially adjacent apices to the next, or can be varied if desired.

As shown in Fig. 1a, certain apices 30 on each side of the annular element 10 can be defined by interconnecting corresponding ends 22 of circumferentially-adjacent strut members directly together to form a zig-zag pattern of

alternating V-shapes when deployed. Alternatively, an apex member can be provided between the corresponding ends of adjacent strut members to form a contoured apex, such as by using a straight apex member to form a flat apex as disclosed in US Patent No. 6,113,627 to Jang, or a curved apex member to form an arcuate apex as disclosed
5 in US Patent No. 5,514,154 to Lau.

In the representative embodiment of Fig. 1a, the strut members 20 of each annular element 10 are interconnected with adjacent strut members 20 to form a continuous closed ring, such as depicted more clearly in Figs. 23e and 24e. As previously noted, however, each annular element can define an open ring to form a
10 rolled sheet or open tubular type structure as described further with regard to Fig. 3, or can define adjacent turns of a continuous helical pattern as described.

Fig. 1a also depicts each strut member 20 of the annular element 10 as a straight member. Preferably, when in the delivery configuration, the straight strut members 20 are generally aligned parallel with the longitudinal axis 15, as well as
15 with each other, as shown for example in Figs. 23c and 24c. Although not shown, alternative strut member shapes can be used in addition to or in lieu of the straight strut members, such as L or V-shaped strut members or the like as is known in the art. Also, the number of strut members included in each annular element will depend upon the size and desired characteristics of the endoprosthesis. For example, a greater
20 number of strut members and interconnecting apices can be provided for increased coverage of the vessel wall by the endoprosthesis or increased cross profile of the endoprosthesis in the deployed configuration.

Similarly, the radial bias or rigidity of each annular element can be controlled or varied by altering the shape or size of the strut members. For example,
25 radial bias or rigidity of an annular element, when deployed, generally can be increased by decreasing the length or by modifying the cross sectional profile of selected strut members of the annular element. It therefore is possible to provide an endoprosthesis in accordance with the present invention having varied radial bias or rigidity along its length by providing one annular element with a radial bias or rigidity
30 that is different from the radial bias or rigidity of another annular element as shown in Fig. 22 and described further below. In a similar manner, it is possible to provide an endoprosthesis having a tapered or flare shape formed of adjacent annular elements having different cross profiles when in the deployed configuration but similar or uniform radial bias or rigidity along its length.

Further in accordance with the present invention, and as previously noted, at least one annular element includes a foot extension extending between at least one pair of circumferentially-adjacent strut members. The foot extension can thus define an apex between the pair of circumferentially-adjacent strut members of the annular element. The foot extension includes a first foot portion extending
5 circumferentially from an end of one of the adjacent strut members and a second foot portion extending circumferentially from a corresponding end of the other of the circumferentially-adjacent strut members. In combination, the first and second foot portions generally define an ankle portion, a toe portion, a base portion and a heel
10 portion of the foot extension, which in combination define a generally circumferentially directed apex.

With reference to the exemplary embodiment of Fig. 1a, for illustration and not limitation, foot extension 40 extends between a pair 9 of adjacent strut members 20 of each annular element 10. As depicted for purpose of illustration, the
15 foot extension 40 includes a first portion 41 extending circumferentially from an end 22 of one of the adjacent strut members 20, and a second portion 43 extending circumferentially from the corresponding end 22 of the other of the adjacent strut members 20. The juncture of the first and second foot portions 41, 43 defines a circumferentially extending toe portion 48 of the foot extension 40. Similarly, and for
20 purpose of discussion and not limitation, Fig. 1a shows that an ankle portion 44 is defined proximate the juncture of the first foot portion 41 with one of the circumferentially-adjacent strut members 20, and that a heel portion 42 is defined proximate the juncture of the second foot portion 43 with the other of the circumferentially-adjacent strut members 20. The toe portion 48 extends in a first
25 circumferential direction a distance greater than the heel portion 42 of the foot extension 40 extends in an opposite circumferential direction. In the embodiment of Fig. 1a, the entirety of the foot extension 40 extends in the circumferential direction of the toe portion 48. Furthermore, at least one of the first and second foot portions 41, 43 defines a base portion 46 at or proximate to the corresponding side 12 or 14 of the
30 annular element 10. Defined generally within the boundary of the first and second portions 41, 43 is an open foot region 49 (see also, Fig. 2a).

With reference again to Fig. 1a, a plurality of connectors 60 are provided to connect adjacent annular elements 10 at a plurality of connection locations 50. Each connection location 50 of Fig. 1a includes a foot extension 40 of

one annular element and an apex 30 of another annular element, with a connector 60 having opposite ends 62 connected therebetween. If desired, however, the connection location 50 can extend from a foot extension to a foot extension, or from an apex to an apex, or to a strut member of one or both annular elements if desired. As embodied in

5 Fig. 1a, each foot extension 40 generally has a circumferentially elongated base portion 46 facing an adjacent annular element 20. With a connector 60 extending longitudinally from the base portion 46 of a foot extension 40 to an apex 30, the longitudinally-adjacent apices 30 of adjacent annular elements are circumferentially out of alignment. The foot base portions 46 at the longitudinal ends 102, 104 of the

10 endoprosthesis 100 face outward from the remainder of the structure. Preferably, one or more foot extensions at either end 102, 104 of the endoprosthesis includes an area that undergoes minimal deformation or strain, such as the base portion 46, when expanded to the deployed configuration. A wire or strip of radiopaque material can be wrapped around or otherwise secured to this area of minimal strain so as to act as a

15 radiopaque marker 120 for imaging purposes. Alternatively, a marker tab or eyelet can be attached at one or both ends of the endoprosthesis as described in detail with reference to Figs. 10 and 11, below. For simplicity and clarity, each connector depicted in Fig. 1a is a straight member. It is recognized, however, that the connector can be contoured or shaped to increase longitudinal flexibility if desired. Similarly,

20 the connectors need not extend parallel to the longitudinal axis, but can be aligned diagonally or helically such that the ends of the connector are circumferentially offset.

A variety of design alternatives for different endoprosthesis embodiments can be achieved by selectively combining the various aspects of the present invention. For purpose of illustration and not limitation, a number of

25 exemplary embodiments including the combination of connectors with foot extensions of the present invention are depicted in planar format in Figs. 3-11. As with the embodiment of Fig. 1a, the connectors are depicted as straight members for clarity and simplicity, but any connector configuration can be used as desired.

As previously described herein, the annular elements are preferably

30 unitarily constructed from a sheet member or a tubular member, wherein the connectors 60 are unitarily constructed along with the annular elements utilizing known construction methods such as laser cutting or etching. In accordance with an alternative embodiment, the annular elements 10 may be constructed individually, either from sheet material or tubular material as described herein, wherein the

connectors 60 are disposed at connection locations 50 thereby forming an endoprosthesis having more than one annular member.

Referring now to Figure 1B, there is shown an alternative embodiment of a connector 60' in accordance with the present invention. In this alternative embodiment, the connectors 60' may be constructed fully of a bio-absorbable material, partially of a bio-absorbable material or of a material different than that of the annular elements 10. By forming the connectors 60' of a bio-absorbable material, mechanical properties of the endoprosthesis can be tuned or adjusted accordingly. For example, a greater number of connectors 60' may be utilized to connect the annular rings 10 together, thereby providing greater column strength for delivery of the endoprosthesis. Once the endoprosthesis has been placed within a vessel or artery, the connectors 60' would then be absorbed thereby allowing each of the annular rings to move independent of one another. By having each of the annular rings 10 able to move independently of one another the flexibility of the endoprosthesis is greatly improved which may lead to a reduction of restenosis. It is further contemplated that individual connectors 60' may be constructed of different bio-absorbable materials, wherein pairs of connectors 60' or individual connectors 60' may be absorbed at different rates. Additionally, pairs of connectors 60' or single connectors 60' may be constructed of non-absorbable materials, wherein the absorbable connectors provide column strength during delivery of the endoprosthesis and the non-absorbable connectors provide connection points between the individual annular rings 10 thereby preventing the annular rings 10 from moving independently, though still providing increased flexibility of the expanded endoprosthesis from the reduction of connectors 60'.

Examples of bio-absorbable materials of which the connectors 60' may be constructed of may be an inert material, a beneficial agent, or a combination of the two. An example of a suitable beneficial agent is described in US Patent No. 6,015,815 and US Patent No. 6,329,386 entitled "Tetrazole-containing rapamycin analogs with shortened half-lives", the entireties of which are herein incorporated by reference. It shall be understood that more than one beneficial agent may be combined with one or more inert materials to form the connectors 60'. Examples of suitable bio-absorbable materials include Polyglycolic acid (PGA),

Polyhydroxybutyric acid, PolyL-Lactic acid (PLLA), Polydilactidel glycolide, Polydilactid acid, PolyDL lactide-co-gycolide.

Further still, as shown in Fig. 1b there is yet an alternative embodiment of the connectors 60' in accordance with the present invention. As shown in Fig. 1b, the connectors 60' are provided to connect adjacent annular elements 10 at a plurality of connection locations 50. Each connection location 50 of Fig. 1a includes a foot extension 40 of one annular element and an apex 30 of another annular element, with a connector 60 having opposite ends 62 connected therebetween. If desired, however, the connection location 50 can extend from a foot extension to a foot extension, or from an apex to an apex, or to a strut member of one or both annular elements if desired. As shown in Fig. 1b, the connector 60'' is partially constructed having a metallic member 60a' and a bio-absorbable member 60b', wherein the bio-absorbable member 60b' is disposed about the metallic member 60a'. By producing the connector 60'' in this manner, the column strength of the endoprosthesis is increased, thereby aiding in tracking and deployment, wherein the bio-absorbable material is then absorbed after deployment and expansion, thereby reducing the column strength of the endoprosthesis.

It may be desirable to choose a bio-absorbable material or materials that can be selectively activated to be made absorbable. For example, after expansion of the endoprosthesis within a vessel or artery, an activating agent may be delivered to the site of expansion, whereby the bio-absorbable connectors 60' are activated thereby becoming absorbable. By making the connectors 60' selectively absorbable, the stiffness and column strength of the endoprosthesis can be varied or altered as desired after implantation. For example, if greater flexibility is desired more connectors may be activated to be absorbed.

It is further contemplated that the bio-absorbable connectors in accordance with the present invention may be configured to be responsive to radio-frequency (RF) energy or ultrasonic energy, wherein the bio-absorbability of the connectors would be altered in response to applied energy. For example, the absorption rate may be increased or decreased in response to the applied energy; additionally it is contemplated that the connectors may be disconnected from the rings in response to applied energy. Suitable RF devices that may be utilized with the present invention include "The Crosser" from FlowCardia or the "Resolution" from OmniSonics Medical Technologies, Inc.

Still further, it is contemplated that the alternative embodiments of the connectors 60 in accordance with the present invention as described above may be constructed either partially or fully of a non-absorbable bio-compatible material. Such a connector configuration would allow of the use of multiple materials for construction of the individual annular rings. For example, a ring constructed of
5 nitinol could be coupled with a ring constructed of a bio-absorbable material or another bio-compatible material, thereby enabling the formation of a composite endoprosthesis.

A variety of configurations can be used for the foot extension in
10 accordance with the present invention. For purpose of illustration and comparison with the foot extension of Fig. 1a, exemplary embodiments of various alternative foot extension configurations are depicted in Figs. 2a through 2f.

For example, the foot extension of the invention generally extends from the pair of circumferentially adjacent strut members circumferentially at an angle relative to a line parallel to the longitudinal axis of the annular element. Fig. 1a
15 shows a foot extension generally extending circumferentially at an angle of about 90 degrees relative to the longitudinal axis 15. However, the foot extension can be configured to extend circumferentially at an angle of less than 90 degrees relative to the longitudinal axis, as shown for example in Fig. 2a.

20 Additionally, Fig. 1a shows a foot extension 40, wherein the first foot portion 41 and the second foot portion 43 are generally parallel, straight elongate portions joined by curved portions. Particularly, the base portion 46 is defined by a generally straight portion and each of the toe portion 48, the ankle portion 44 and the heel portion 42 is defined by a curved portion. Each portion of the foot extension 40,
25 as well as each of the circumferentially-adjacent strut members 20, has a substantially uniform width W and thickness in the embodiment of Fig. 1a. In this manner, the circumferentially-adjacent strut members 20 will be substantially parallel to the longitudinal axis 15 and to each other, and region 49 will be substantially closed when in the delivery configuration. As depicted in Fig. 1a, the foot extension 40 will thus
30 generally define at least two areas of flexure between the pair of circumferentially-adjacent strut members 20; that is, one at the heel portion 42 and one at the ankle portion 44. An additional, or alternative, area of flexure can be defined at the toe portion 48 if desired to facilitate further expansion between the pair of

circumferentially-adjacent strut members 20, such as to define a three point hinge configuration.

Fig. 2a depicts a preferred embodiment of a foot extension similar to that of Fig. 1a. As previously noted, however, the foot extension 40 of this
5 embodiment extends circumferentially at an angle \times less than 90 degrees relative to the longitudinal axis 15. Additionally, the first and second foot portions 41, 43 are generally parallel but spaced apart to define a relatively more open region 30 than that of the foot extension of Fig. 1a. To control expansion of the annular element, the width of the foot extension and circumferentially-adjacent strut members can be
10 varied accordingly. For example, and as previously noted, circumferentially-adjacent apices along each side of the annular element 10 are spaced apart by a circumferential distance D, wherein the distance D generally increases as the annular element is expanded. It is often desirable to balance an annular element so as to expand uniformly, wherein the distance D increases a similar amount and at a similar rate
15 between each pair of circumferentially-adjacent apices. Due to the increased flexure facilitated by the foot extension similar of Fig. 1a, the distance Df between the circumferentially-adjacent apices located at the end of the pair 9 of circumferentially-adjacent strut members 20 opposite the foot extension 40 can increase to an extent or at a rate greater than the distance Da between other circumferentially-adjacent apices
20 of the annular element. By providing the first and second foot portions 41, 43 of the foot extension with an average width greater than the average width of the circumferentially-adjacent strut members 20, as shown in Fig. 2a, the expansion between the circumferentially-adjacent apices 30 can be controlled or even balanced if desired. For example, and as shown in Fig. 2a, the first and second foot portions
25 41, 43 can be provided with a substantially constant width. Alternatively the first foot portion 41 can be provided with a width W1 different than that W2 of the second foot portion 43.

As previously noted with regard to the exemplary embodiment of Fig. 1a, the circumferentially-adjacent strut members 20 and the different portions of the
30 foot extension 40 can be provided with a substantially uniform width and thickness throughout. If the foot extension is provided with an increased width, it may be desirable or necessary to distribute stress or eliminate stress concentrations in the pair of circumferentially-adjacent strut members 20. As embodied in Fig. 2a, at least one

or both strut member 20 of the pair 9 of circumferentially-adjacent strut members can be provided with a varied width. For example, and as shown in Fig. 2a, each strut member of the pair 9 of circumferentially-adjacent strut members can be tapered from a first width W' substantially similar to or even greater than that of the foot extension at the first end 22' of the strut member to a second width W'' substantially similar to or even greater than that of the adjacent strut member 20 connected at the second end 22".

To further control expansion of the annular element, selected apices along the same longitudinal side 12, 14 of the annular element 10 as the foot extension also can be modified. For example, an apex 30 can be relaxed by reducing its width to facilitate greater expansion, or stiffened by increasing its width to facilitate less expansion. As shown in Fig. 2a, the width of selected apices 30rw are reduced to relax the apex 30 and thus control, such as balance, expansion of the annular element as needed or desired.

Furthermore, selected apices on the same side of the annular element as the foot extension can be configured to accommodate additional features. For example, and in accordance with another aspect of the present invention, it is desirable to enhance retention of a balloon expandable endoprosthesis on a balloon delivery system. As shown in Fig. 2a, the foot extension 40 extends in a first circumferential direction, and a circumferentially-adjacent apex 30a is located proximate the foot extension 40 in the first circumferential direction. When in the delivery configuration, this circumferentially-adjacent apex 30a is longitudinally aligned with, and preferably can substantially contact, the toe portion 48 of the foot extension so as to define a gap G between the circumferentially-adjacent strut members 20. Balloon material of the delivery system thus can be captured within this gap G, during crimping or through known heat treatment techniques, to enhance stent retention on a balloon. Additionally, or alternatively, a gap can be defined within an enlarged region 49 of the foot extension 40 for similar stent retention purposes if desired.

Fig. 2b depicts yet another foot extension configuration in accordance with the invention. The first foot portion 41 of the foot extension 40 is generally angled relative to the second foot portion 43, rather than aligned in parallel as shown in Fig. 1a. Additionally, the second foot portion 43 is generally V-shaped to define a base portion 46 extending substantially perpendicular to the longitudinal axis, but

with a more angular heel portion 42 than that of Fig. 1a. In this manner, the first and second foot portions define an enlarged open region 49 relative to that of Fig. 1a. As with Fig. 2a, the embodiment of Fig. 2b includes a foot extension 40 having an increased average width and tapered circumferentially-adjacent strut members, as well as a longitudinally-aligned apex 30a circumferentially adjacent to the toe portion 48 of the foot extension 40 for enhanced retention on a balloon delivery system.

Fig. 2c depicts an alternative preferred embodiment of the foot extension of the present invention. The foot extension 40 of this embodiment is provided with a generally rectilinear configuration, including a first foot portion 41 extending from the ankle portion 44 to the toe portion 48 of the foot extension, and a second foot portion 43 extending from the heel portion 42 to the toe portion 48. Particularly, the second foot portion defines a contoured base portion 46, such as a generally V-shape including a first portion 46' and a second portion 46". In this manner, the foot extension can be configured to provide an additional area of flexure for expansion of the annular element if desired, as well as to define a connection location for longitudinally-adjacent annular elements as described further below.

As with the embodiments of Figs. 2a and 2b, the first and second foot portions 41, 43 of Fig. 2c are provided with an increased width to stiffen the apex defined by the foot extension 40, and thus control, and more preferably, balance expansion of the annular element 10. For example, in one preferred embodiment, the width $W1$ of the first foot portion 41 and the width $W2'$ of the first portion 46' of the V-shaped base portion are equal to each other, but different than the width $W2''$ of the second portion 46" of the V-shaped base portion. Unlike the embodiment of Figs. 2a and 2b, which are particularly advantageous in combination with a balloon delivery system, the embodiment of Fig. 2c does not include a longitudinally-aligned apex circumferentially adjacent the toe portion of the foot extension. Rather, and as recognized from Fig. 2c, at least the apex 30a located circumferentially proximate the toe portion 48 of the foot extension 40 is positioned longitudinally so as to mate with the foot extension when in the delivery configuration. For example, and as shown in Fig. 2c, this can be accomplished by providing at least one of the strut members 20 of the pair 9 of circumferentially-adjacent strut members with a length greater than the length of the remaining strut members of the annular element. The mating configuration between the foot extension 40 and the circumferentially adjacent apex 30a facilitates a reduced cross profile of the annular element 10 when in the delivery

configuration. This embodiment is particularly advantageous for an endoprosthesis to be delivered within extremely small vessels, such as certain coronary or neurovascular vessels, or for an endoprosthesis that can be contained within a sheath during delivery, such as a self-expanding stent.

5 Fig. 2d is an enlarged detail view of a more rounded version of a foot extension similar to that of Fig. 2c, which is depicted with dashed lines for purpose of comparison. Particularly, Fig. 2d demonstrates the use of more rounded contours to shift or eliminate stress concentrations that may occur during expansion.

10 Fig. 2e depicts another alternative embodiment of a foot extension the present invention, which incorporates the mating configuration of the foot extension and the circumferentially adjacent apex as described with regard to Fig. 2c. Unlike the embodiment of Fig. 2c, however, the strut members 20 connected to the circumferentially adjacent apex 30a are provided with a length less than that of the remaining strut members so as to accommodate the desired mating relationship
15 between the apex 30a and the foot extension 40. Furthermore, Fig. 2e shows that at least the circumferentially adjacent apex 30a is relaxed, such as by providing a reduced width, to open at a greater angle and thus compensate for the decrease of the distance D that would otherwise result during expansion due to the reduced length of the corresponding strut members 20. As previously described, expansion of the
20 annular element 10 thus can be controlled, and more preferably, balanced. The strut members 20 having a reduced length and the circumferentially-adjacent apex 30a also can be provided with a reduced width if desired as shown in Fig. 2e.

Referring now to Fig. 2f there is shown yet another embodiment of a foot extension in accordance with the present invention, as shown in Figure 2f, the
25 foot extension 40' includes a first foot portion 41 extending from the ankle portion 44 to the toe portion 48 of the foot extension, and a second foot portion 43 extending from the heel portion 42 to the toe portion 48, wherein a modulator member 47 is disposed adjacent the ankle portion 44 and the heel portion 42. The modulator member 47 couples two adjacent strut members as shown. The modulator member 47
30 may be formed having a width similar to the adjacent strut members or may be constructed having a width that is greater than or less than the adjacent strut members or foot extension. Additionally, the modulator member 47 may be constructed as a linear member or as a member having an arc length, wherein upon expansion of the endoprosthesis from a contracted or crimped profile to an expanded profile the

modulator member 47 may be designed to limit the expansion diameter of the endoprosthesis by redistributing stress/strain away from the foot portion of the endoprosthesis, thus, resulting in more uniform expansion/contraction of the endoprosthesis. Additionally, as shown in Fig. 2f, the placement of the modulator member 47 creates a well or open space 49 defined by the foot portion 40' and the modulator 47. It is contemplated that the space 49 may be utilized as a reservoir for a beneficial agent such as those described herein and in detail below. Additionally, it is contemplated that at least one radiopaque marker member may be placed into at least one of the spaces 49 as described in greater detail below with regard to the methods and processes described below.

The modulator 49 may be constructed of a bio-absorbable material in a similar manner to the connector 60' as previously described. Additionally, the modulator may have a composite construction wherein a portion of the modulator 49 is constructed of the same material as the endoprosthesis and the second portion is a different material. The second material may be a bio-absorbable material such as those previously described, or a beneficial agent, or a non-absorbable bio-compatible material.

Referring now to Figs. 2G through 2K there is shown an alternative embodiments of the modulator component in accordance with the present invention. As shown in Figs. 2G and 2H the modulator is constructed having bistable properties. As shown in Figs. 2I through 2K there is shown a multi-piece modulator, wherein the multiple pieces of the modulator function together in a manner described below.

Referring now to Figs. 2G and 2H there is shown an alternative embodiment of the modulator disposed between the apices interconnecting corresponding ends of circumferentially adjacent strut members. The modulator can be provided having an arcuate structure with at least two segments 502, 504 defining an internal area 506 therebetween. The first segment 502 is generally wider than the second segment 504 making the second segment less resistant to flexure. Each segment has a first and a second end. Corresponding ends terminate adjacent to each other and connect with the corresponding strut members 508, 510. In an unexpanded configuration, the first segment generally cradles the second segment.

An expansion force may be supplied by a balloon member for a balloon expandable stent and through the removal of a sheath for a self expanding stent as is generally known in the art, which causes expansion of the stent. The

second segment 504 of the arcuate structure has bimodal stability such that it exists in one mode prior to expansion, and changes to a second mode after expansion, shown in Fig. 2H. The mode shift is characterized by the foci 512 of the second segment radius everting from one side of the second segment to the other. The mode shift results in
5 an increase of the internal area 506 and the radius of the first segment 502. The increased radius of the first segment 502 corresponds to an increase in the angle 514 defined between the corresponding strut members thereby resulting in an increased stent diameter after the expansion force is removed.

Reversal of the second segment 504 to the first stable mode is possible
10 when adequate compressive loading is applied to the stent structure, and this compressive loading is preferably higher than the load supplied by the in vivo anatomy.

Further, it is notable that the mechanism of expansion described in this alternative embodiment does not rely upon plastic deformation of the stent material,
15 making it suitable for fabrication from stent materials such as bioabsorbable polymers.

In an alternative embodiment shown in Fig. 2I, the strut members may include generally opposed projections 552, 554 located on facing surfaces of the strut members. The opposed projections 552, 554 are designed to move relative to each
20 other during expansion of the endoprosthesis structure, thereby allowing expansion of the endoprosthesis to a larger diameter. The expansion force is preferably supplied by a balloon element as is generally known in the art. During expansion, the projections will come into contact thereby providing a normal force against the surface of the other projection.

As shown in Fig. 2J, the endoprosthesis is designed to expand to a
25 diameter large enough to allow the apex of a first projection 552 to pass beyond the apex of the second projection 554. As the apices pass each other, the contact between the projections ceases, and the apex of the first projection 552 is able to move beyond the apex of the second projection 554.

Referring now to Fig. 2K, upon removal of the expansion force, the
30 recoil path of the first projection 552 apex causes it to contact a second side of the second projection 554. The contact between the two projections interferes with the relative movement of the projections 552, 554 thereby resisting recoil of the overall stent structure and resulting in the angle 556 defined between the strut members being

larger in the expanded position than in the unexpanded position. The surfaces of the projections may be modified to increase frictional forces between the projections during contact, thereby resisting recoil. Additionally, it is contemplated that features, such as notches and latches which interact with each other to "lock" the two
5 projections together when the stent is in an expanded state.

Further, it is notable that the mechanism of expansion described in this alternative embodiment does not rely upon plastic deformation of the stent material, making it suitable for fabrication from stent materials such as bioabsorbable
10 polymers.

Additional variations of the foot extension are also contemplated. For example, the heel portion of the foot extension can extend in a circumferential direction opposite from the toe, but preferably by a distance less than the distance over which the toe extends in the first direction.

Any suitable number of foot extensions can be provided on an annular
15 element in accordance with the present invention. A single foot extension can be provided on an annular element if desired. As shown in the embodiment of Fig. 1a, however, it is preferable to define a plurality of apices of an annular element with foot extensions 40, wherein each foot extension extends between a pair
20 circumferentially-adjacent strut members. The foot extensions can be provided on both longitudinal sides 12, 14 of the annular element 10 as shown in Fig. 1a, or only on a single side of an annular element as shown in Fig. 8. Additionally, and as further shown in Fig. 8, it is possible to combine an annular element having one or more foot extensions with another annular element having no foot extension if desired. The
25 plurality of foot extensions, if provided, can all extend in the same circumferential direction, or in opposite circumferential directions if desired. For example, and as shown in Fig. 1a, the foot extensions on one longitudinal side of each annular element can extend in one direction circumferentially 17, whereas the foot extensions on the other side of the annular element extend in the opposite circumferential direction. In
30 other embodiments, such as Fig. 6, all foot extensions 40 can extend in the same circumferential direction, either clockwise or counterclockwise when viewed from one end of the endoprosthesis, regardless of the longitudinal side 12, 14 of the annular elements 10 on which the foot extensions 40 are disposed.

When a plurality of foot extensions are provided on an annular element, the foot extensions can be evenly spaced along the corresponding side of the

annular element as shown in Fig. 1a, or can be spaced in a staggered fashion as shown in Fig. 4. The number of apices that are not defined by a foot extension along the corresponding side of the annular element, and thus disposed between foot extensions, will depend upon the total number of apices desired for the annular element and the total number of such apices to be defined by a foot extension.

Further in accordance with the present invention, and as previously noted when a plurality of annular elements is provided, the first annular element and the second annular element are connected to each other at a connection location. A single connection location can be provided between two adjacent annular elements, or a plurality of connection locations can be provided as preferred. Furthermore, and as described below, the connection location can include one or more connectors extending between adjacent annular elements, or the connection location can be defined by an overlapping geometric pattern of two adjacent annular elements.

Preferably, the connection location includes a foot extension. As previously noted, each foot extension defines at least two areas of flexure. Such areas of flexure generally are located in the ankle, toe or heel portions of the foot extension. As such, the foot extension can facilitate greater longitudinal flexibility when included at the connection location between two adjacent annular elements. The multiple areas of flexure of the foot extension can also compensate for foreshortening when disposed at the connection location. As the annular element is expanded, the foot extension can be configured to open in a manner to adjust or compensate for some or all of the change that occurs in the longitudinal dimension of the annular element. That is, the foot extension can be configured to have a first longitudinal dimension when in the delivery configuration, and to straighten or retract, as deemed necessary, so as to have a second longitudinal dimension when in the deployed configuration. The difference between the first longitudinal dimension and the second longitudinal dimension of the foot extension preferably is substantially equivalent to the corresponding change in the longitudinal dimension of the annular element. Similarly, the foot extension can be stiffened by increasing the width of one or both of the first and second foot portions, or by otherwise altering the geometry of the foot extension in a suitable manner, to reduce the amount in which the foot extension opens, and thus reduce the extent of related foreshortening that occurs at the connection location.

Additionally, when located on a corresponding side between longitudinally-adjacent annular elements, the foot extension of one annular element includes a base portion generally facing the other annular element. The base portion provides an elongated region in which a connection location can be disposed, thus increasing versatility for design alternatives. For example, one alternative for increasing coverage provided by a stent is to configure corresponding zig-zag or sinusoidal patterns of longitudinally-adjacent annular elements less than 180 degrees out of phase with each other. That is, with the first side of a first annular element longitudinally adjacent the second side of a second annular element, it can be desirable for the apices proximate the first side of the first annular element to be circumferentially out of alignment with the apices proximate the second side of the second annular element. The foot extensions of the present invention allow such circumferential offset between longitudinally adjacent apices, even without the use of a connector. The foot extension of the present invention therefore enables greater axial flexibility, foreshortening compensation, radial expansion and coverage of the endoprosthesis.

The embodiment of Fig. 3, shown substantially in a delivery configuration, includes a plurality of annular elements 10, wherein each longitudinal side of an annular element has sixteen (16) apices. In this embodiment, four apices on a selected side, e.g. twelve (12), of adjacent annular elements 10 are defined by a foot extension 40, wherein the foot extensions 40 extend in the same longitudinal direction but in alternate circumferential directions from one annular element 10 to the next. Each foot extension 40 is configured substantially similar to that of Fig. 2c, wherein the base portion 46 is contoured to include first and second portions. The contoured pattern of the base portion 46 of each foot extension 40 overlaps with the pattern of an apex 30 of the circumferentially-adjacent annular element. Hence, four connection locations 50 are provided between longitudinally-adjacent annular elements 10, with three apices 30 disposed between the connection locations 50 along the corresponding longitudinal side 12, 14 of each annular element 10. The annular element 10 at the longitudinal end 102 of the endoprosthesis 100 in which the foot extensions 40 are directed is free of foot extensions 40. Fig. 4 shows an alternative embodiment similar to that of Fig. 3, wherein the lengths of the strut members 20 disposed circumferentially between the foot extensions 40 are varied to reduce the gap area

defined between longitudinally-adjacent annular elements 10, and thus increase coverage.

Fig. 5 shows an alternative embodiment similar to that of Fig. 3, wherein the center apex disposed along the longitudinal side 12, between the foot extensions 40b that define connection locations is defined as a foot extension 40a. In this manner, circumferentially-adjacent foot extensions 40 along a longitudinal side of an annular element 10 are separated by single apex 30, wherein every other foot extension 40b forms a connection location with an apex 30 of a longitudinally-adjacent annular element 10. Fig. 6 shows an enlarged detail of an embodiment similar to Fig. 5, in the delivery configuration, wherein the base portion 46 of each foot extension 40 has an increased average width as previously discussed with regard to Fig. 2c. Particularly, the base portion 46 of each foot extension 40 is contoured with a generally V-shape to include a first portion 46' and second portion 46". The second portion 46" proximate the toe portion has a width greater than the first portion 46' as previously discussed. Furthermore, the foot extensions 40 of Fig. 6 are all directed in the same circumferential direction.

Fig. 7 shows an embodiment similar to that of Fig. 3; however, each annular element includes additional strut members and apices. Particularly, the embodiment of Fig. 7 includes 20 apices, rather than 16 apices, on each side of each annular element 10, with every other apex defined by a foot extension 40. Hence, five connection locations 50 are defined between adjacent annular elements 10. The embodiments of Figs. 8 and 9 are similar to the embodiment of Fig. 7; however, selected apices 30s of one annular element are longitudinally aligned to be disposed between circumferentially adjacent foot extensions 40 of an adjacent annular element. As previously noted, and in accordance with the invention, the apices on longitudinally adjacent sides of adjacent annular elements 10 can be disposed so as to be circumferentially out of alignment with each other. Hence, the strut members 20s that are interconnected at the apices 30s disposed between adjacent foot extensions 40 of an adjacent annular element, are provided with a greater length than the remaining strut members so as to dispose the apex 30s generally between the foot extensions 40. In this manner, resulting coverage and scaffolding can be increased. Each of Figs. 7-9 is shown substantially in a delivery configuration.

Fig. 10 discloses an embodiment in a slightly deployed configuration having eight apices per side of each annular element 10. Each annular element 10 is

arranged in a diagonal format to define a 360-degree turn of a helical pattern. In this manner, the circumferential end 18 of one annular element can be joined with the corresponding circumferential end 16 of a longitudinally-adjacent element to form a continuous helical pattern along the length of the endoprosthesis 100. Two apices on one side of each annular element are defined by foot extensions 40 similar to that of Fig. 2b. Each foot extension 40 forms an overlapping pattern with the apex 30 on a circumferentially adjacent side of an adjacent annular element. Hence, two connection locations 50 are defined between adjacent annular elements 10. As previously noted with regard to Fig. 2b, the apex 30a circumferentially adjacent to the foot extension 40 is longitudinally positioned to substantially contact the toe portion 48 when in the delivery configuration to increase coverage, as well as to capture balloon material if desired. The embodiment of Fig. 10 also includes an eyelet or tab to incorporate a radiopaque marker 120 at one or both ends 102, 104 of the endoprosthesis if desired. Alternative techniques for incorporating radiopaque material are described below.

In accordance with the present invention the endoprosthesis 100 may further include at least one radiopaque marker disposed in an eyelet that is integrally formed with the endoprosthesis' pattern. The radiopaque marker preferably is formed of a material having greater radiopacity than that of which the endoprosthesis is constructed of. In a preferred embodiment, the radiopaque marker is formed according to the process described in greater detail below, wherein a first head is pre-formed on one side of the marker through a pre-forming process, the pre-formed marker is then inserted into the eyelet and a second forming process is performed to deform the second end of the marker and form a second head. Wherein the two heads retain the marker within the eyelet with high confidence. Additionally, the two marker heads create an interference fit between the marker and the marker housing. In accordance with the present invention and with reference to Figures 11 through 19 the process of adding markers to an endoprosthesis will be described in greater detail below.

Referring now to Fig. 11, there is shown an exemplary embodiment of an endoprosthesis according to the present invention, wherein the endoprosthesis includes at least one marker housing adjacent to one end of the endoprosthesis wherein a marker may be disposed therein. As shown in Fig. 11, the endoprosthesis includes a plurality of strut members having first and second ends, wherein at least

one pair of adjacent strut members further include a foot extension as previously described. The foot extension further includes a marker housing 121, wherein the marker housing is configured to retain a marker 120. As shown in Figure 11, the marker housing is attached to an apex 30 on one end 104 of the endoprosthesis and extends from a foot extension 40 on the opposite end 102. The marker housing(s) as shown in Fig. 11 are shown extending along an axis of either the apex or foot extension, though it is contemplated that the marker housings may extend from the apex and foot extension at an angle relative to an axis of the apex or foot extension. Marker housing 121 is designed such that the mechanical properties of the foot extension and/or the endoprosthesis are not affected. Alternatively, it is contemplated that the marker housing 121 may be design such that the marker housing 121 functions as a structural member of the endoprosthesis. As shown, the marker housing 121 includes an aperture formed therein, whereby the aperture is formed having a generally circular shape. Although, the aperture formed in the marker housing is described as being generally circular in shape, it is contemplated that the aperture may be formed having other shapes, such as rectangular, square, oval, octagonal, and the like. As shown in Fig. 11, at least one marker housing may be additionally formed on the opposite side of the endoprosthesis device 100, wherein the second marker housing 121 is configured to be in association with one of the apices formed by the plurality of strut members as described previously.

As described above, a marker 120 may be disposed within the aperture of the marker housing. The marker may be composed of any material having greater radiopacity than the material from which the endoprosthesis device 100 is constructed. Examples of suitable material include, stainless steel, gold, silver, cobalt, platinum, iridium, tantalum, and alloys thereof or similar biocompatible materials. It is further contemplated that the marker may comprise bioabsorbable materials, wherein the bioabsorbable materials may further include a beneficial agent, wherein the beneficial agent is configured to elute from the bioabsorbable material over a determined period of time or at a controlled rate. In a preferred embodiment, the marker comprises tantalum and is embodied in the form of a form of a rivet, wherein the rivet includes first and second heads and is formed as a generally cylindrical member. It is contemplated that the marker may be manufactured as a composite, wherein one material may be radiopaque and the other material may be a

beneficial agent. Wherein the beneficial agent may be configured to elute from the marker after implantation of the endoprosthesis.

Referring now to Fig. 12 there is shown an exemplary embodiment of a rivet in accordance with the present invention. As shown in Fig. 12, the rivet 120 includes a first end 120a and a second end 120b, wherein first head 122 having an enlarged diameter portion is formed on the first end through a forming process described in greater detail below. The enlarged diameter portion 122 is configured to retain the rivet within the aperture of the marker housing 121 prior to the formation of a second head on the second end of the marker as described below to form the rivet.

In a preferred embodiment, the rivets 120 are formed by first cutting generally cylindrical members having pre-determined length from round stock, wherein the cut portions may then be tumbled to radius and deburr the cut edges. These cylindrical members are then annealed at about 1,950 degrees Fahrenheit for at least about one hour at high vacuum in argon or other inert environment. The annealing process reduces the likelihood of the formation of cracks or other defects due to the forming process. In a preferred embodiment, the cylindrical members are formed from tantalum wire, wherein the tantalum wire conforms to ASTM F 560-9 or similar specification. The rivets are then processed to produce the enlarged diameter portion. In a preferred embodiment, the enlarged diameter portion is formed on one end of the marker stock by placing the cylindrical member(s) in a holding fixture, wherein an off-center drill press is advanced until the tip of a forming mandrel contacts the surface of the marker stock, whereby the off-centered mandrel displaces material radially to form an enlarged diameter portion. The off-centered mandrel remains in contact with the marker material for a period between about 1 second and 20 seconds, and more preferably between about 4 seconds and about 8 seconds. The pre-formed marker head created through the process above and illustrated in Figure 12 should have a diameter between about .010 inches and about .025 inches, more preferably between about .015 inches and about .020 inches. It shall be understood that the above times and diameters given above should be considered exemplary, in that other times and diameters may be used. Further still, the rivets may be manufactured utilizing other known techniques such as injection molding, casting, machining, hydroforming and the like.

It is further contemplated that the marker 120 may be formed with alternative methods, for example, the marker may be integrally formed with the

endoprosthesis device during the initial manufacturing step. Such a process would involve manipulating a tubular member or a sheet of material from which the endoprosthesis device is constructed from prior to the formation of the endoprosthesis device. For example, if the endoprosthesis were to be formed from a thin-walled tubular member, a groove or other feature may be formed in one of the walls of the tube, wherein a radiopaque material may then be disposed within the groove or feature. Alternatively, the locations of the marker housing may be pre-formed on the device wherein markers may pre-disposed within the marker housings prior to the manufacture of the endoprosthesis device, which may then be formed according to known methods and those described herein.

Referring now to Fig. 13, there is shown a marker housing wherein a rivet has been disposed within the aperture of the housing, wherein the enlarged diameter portion 122 of the rivet extends beyond the outer surface of the endoprosthesis device 100 and the second end 120b of the rivet has been deformed to form a second enlarged diameter portion as shown. By forming the second enlarged diameter portion adjacent the second end 120b of the rivet, the rivet 120 is retained within the marker housing with a frictional fit and/or a mechanical interference of the enlarged diameter portions and the inner and outer walls of the endoprosthesis device. In a preferred embodiment, the second enlarged diameter portion is formed on the second end of the cylindrical member by the following process steps. After having formed the first enlarged diameter portion on the cylindrical member, the pre-formed marker is placed within an eyelet of the endoprosthesis. The marker is then pre-set into the eyelet. The marker may be pre-set into the eyelet with a pair of marker seating pliers, the marker seating pliers having a pair of jaws, one jaw having a smooth surface the other having a cavity formed therein. The un-formed side of the marker is received within the cavity of the pliers; force is then applied to the jaws of the pliers to close the jaws, thereby seating the marker within the eyelet. This process is repeated until markers have been disposed within all eyelets. It is further contemplated that the pre-formed markers may be inserted into the eyelets using an automated system.

The eyelet portion of the endoprosthesis is placed into a holding fixture, wherein the fixture is configured to retain the endoprosthesis in a desired position such that the second head may be formed on the second end of the marker. Referring now to Fig. 14, there is shown a side view of the fixture 200 in accordance

with the present invention. As shown, the fixture includes a first half 210 and a second half 220, wherein the first half is slidably disposed relative to the second half. The first half further includes an endoprosthesis receiving member 211, as shown in Fig. 15, wherein the receiving member 211 has a diameter generally equal to an inner diameter of the expanded endoprosthesis. The receiving member further includes a bore extending through the receiving member, the bore aligned perpendicular to an axis extending longitudinally through the receiving member. A marker-forming pin 213 is disposed within the bore, wherein the marker forming pin 213 has a proximal end and a distal end 214, the distal end of the pin having a generally convex surface. The generally convex surface configured to engage the second end of the marker and form the second head thereon. A locating pin 212 is disposed in a second bore, the second bore aligned perpendicularly to the first bore and offset from the axis of the receiving member, wherein the locating pin 212 engages a portion of the marker forming pin 213, thereby locating the pin 213 relative to the receiving member 211 and the second end of the marker (not shown).

The second half 220 of the fixture 200 is configured to receive and retain the eyelet of the endoprosthesis while the second head is being formed. As shown in Fig. 14, the second half 220 of the fixture 200 includes a receiving member 240. Referring now to Fig. 16, there is shown a partial plan view of the receiving member 240. As shown in Fig. 16, the receiving member 240 includes an eyelet shaped cutout 252, the eyelet shaped cutout configured to receive the eyelet portion of the endoprosthesis when the first half of the fixture is slidably moved toward the second half to form the second head. Additionally, a marker receiving pin 260 is disposed within a bore of the receiving member 240, wherein the marker receiving pin 260 is axially aligned with the marker forming pin 213 of the receiving member 211.

In use, after having disposed a pre-formed marker into an eyelet of the endoprosthesis, the endoprosthesis is disposed over the receiving member, wherein the eyelet and second end of the marker is aligned with the marker forming pin 213. The fixture 200 is then placed into a force applying device, and a force is applied to the first half 210 of the fixture, wherein the first half 210 advances toward the second half 220. In an alternative embodiment a hard stop disposed on the second half would be configured to limit the travel of the first half beyond a desired distance. In a preferred embodiment, the first half 210 travels between about .05mm and 1.5mm more preferably between about .08mm and 1mm after initial contact of the marker

forming pin 213 with the second end of the marker. As the first half advances to the second half, the marker-forming pin 213 engages the second end of the marker and deforms the second end, thereby forming the second head on the marker as shown in Fig. 13. In a preferred embodiment, a force between about 5N and 300N is applied to the fixture 200, and more preferably a force between about 10N and 250N. The force is removed from the fixture and the endoprosthesis is then removed from the receiving member. This process is repeated until all eyelets contained finished markers. In a preferred embodiment, the finished markers have total height of between about .005 inches and about .025 inches, and more preferably between about .010 inches and about .015 inches.

Referring now to Fig. 17 there is shown an alternative embodiment of the receiving member 240 of the fixture 200 in accordance with the present invention. As shown in Fig. 17, the receiving member 340 includes a plurality of eyelet receiving members, a motor and means for translating the eyelet receiving members between a first position and a second position.

As shown in Fig. 17, the eyelet receiving members 370 are radially disposed adjacent to each other and slidable between said first and second position. Each eyelet receiving member 370 further includes a first end and a second end, the second end including a fitting 372, as shown in Fig. 18, wherein the fittings 375 are configured to engage an eyelet of an endoprosthesis. Each eyelet-receiving member is associated with a locating pin 380, the locating pin is disposed within an aperture formed in each eyelet receiving member and is disposed perpendicular to the eyelet receiving member, wherein the locating pins have a first end 382 and a second end 381. The second end 382 of each locating pin 380 is received within a groove 392 formed in a first surface of a rotating member 390. The rotating member 390 is coupled to a motor 395 or other rotating means, wherein a control module (not shown) is associated with the motor 395 to control the rotation of the rotating member, and thereby controlling the translation of the eyelet receiving members from the first position to the second position.

The process of forming a marker utilizing the alternative embodiment of the fixture illustrated in Fig. 14 is similar to that described above, wherein after a marker has been disposed in an eyelet as described above, the endoprosthesis is loaded onto the first half of the fixture as described above, the first half of the fixture is then advanced toward the second half of the fixture. In response to the

advancement of a first half, a control signal is generated and transmitted to the motor 395, wherein in response to the control signal, the motor provides rotational translation of the rotating plate 390, thereby translating the eyelet receiving members 370 from the first position, wherein the distal ends of the eyelet receiving members are spaced apart from each other, as shown in Fig. 18, to a second closed position, wherein the distal ends 372 of the eyelet receiving members are disposed adjacent to each other, as shown in Fig. 19. When the eyelet receiving member are disposed in the second position, the eyelet of the endoprosthesis is thereby retained by the features formed in the distal ends of the eyelet receiving members, wherein the second head of the marker can then be formed according to the process described above.

It is further contemplated that the rivet as shown in Fig. 12 may be constructed of multiple pieces which may then be assembled to form a single member when disposed within a marker housing in accordance with the present invention. For example, the rivet may comprise upper, middle, and lower pieces, wherein the middle piece includes means to affix the upper and lower pieces thereto, such as a protrusion extending from each end of the middle piece, wherein the upper and lower pieces include an aperture or recessed area configured to receive the protrusion. Alternatively, a fourth piece may be utilized to affix the upper, middle and lower pieces together to form a marker in accordance with the present invention.

Although the marker housings are shown and described as being disposed on either end of the endoprosthesis device of the present invention, it is further contemplated that marker housings may be formed anywhere along the length and/or radius of the endoprosthesis device in accordance with the present invention. Markers disposed anywhere along the length of the endoprosthesis may be utilized to denote the location where the physical properties of the endoprosthesis changes, or where a diameter change occurs, or the location of a side opening formed in the wall of the tubular member.

In addition to the embodiments shown above in Figs. 10 through 13, it is contemplated that the marker housings may be formed within an apex of one or more strut members or within a portion of the foot extension of the embodiments shown and described herein. Additionally, it is contemplated that a marker housing may be formed anywhere along the length of the endoprosthesis in accordance with the present invention. For example, it may be desirable to have markers disposed anywhere along the length of the endoprosthesis between each end of the

endoprosthesis. Therefore, in accordance with the present invention, it is contemplated that marker housings may be formed for example in the middle of the endoprosthesis to indicate a specific area or property of the endoprosthesis. As such, markers may be disposed in marker housings formed within the struts, apices, or foot members of the endoprosthesis, or marker housings such as those shown in Figs. 10 and 11 maybe integrated in the endoprosthesis anywhere along the length of the endoprosthesis. Further still, a variety of the marker embodiments described and shown herein may be utilized in any combination along the length of an endoprosthesis according to the present invention, wherein different marker
5
10
15
20
25

Fig. 20 is an enlarged view of a connection location similar to that of Fig. 10, wherein the overlapping geometric pattern of a connection location is schematically depicted for purpose of illustration. Particularly, Fig. 20 shows an annular element having a foot extension similar to that of Fig. 2a. The pattern of the foot extension 40b along the base portion 46 is aligned longitudinally to overlap with a portion of the pattern of a circumferentially adjacent annular element 10. The resulting configuration of the overlapping pattern defines the connection location 50 between the two annular elements 10. The amount or extent of overlap between the two patterns can be varied as desired. For example, the patterns can be substantially in tangential contact, or can be fully overlapping. Additionally, fillets or a similar transition can be included to smooth or eliminate any sharp or abrupt edges. It is noted that the thickness at the juncture defined by the overlapping patterns need not be, and preferably is not, increased. Rather, the overlapping pattern refers to the resulting configuration when two separate patterns share a common surface or area.

Figs. 21a through 21d show alternative connection locations 50 defined by different degrees of geometrical overlap between adjacent annular elements 10. The connected foot extension 40b and apex 30 of Fig. 21a have a slight geometrical overlap, such as a tangential surface contact. Fig. 21b shows an overlapping pattern, wherein the connected apex 30 and foot extension 40b fully overlap to substantially share a common member. As depicted, the apex 30 at the connection location 50 extends longitudinally further than the unconnected apices 30. In Fig. 21c, the apex 30 at the connection location 50 protrudes into the foot region of the corresponding foot extension 40b. In this embodiment, the foot extension 40b is generally enlarged and rounded at the base portion 46 compared to free foot extensions 40a to stiffen and

reinforce the connection location 50. Additional areas of flexure can be defined by the contour of this configuration, as compared to that of the other foot extensions. By contrast, connected foot extension 40b of Fig. 21d includes a flattened base portion 46 substantially perpendicular to the longitudinal axis to define a more relaxed configuration. As with Fig. 21c, the connected apex 30 of this embodiment overlaps with the foot extension 40b and protrudes into the foot region 49.

As noted above, the various aspects of the present invention allow for a variety of different endoprosthesis embodiments, based upon selective combinations of the features previously described and shown. Similarly, the endoprosthesis of the present invention can be made using any of a number of known manufacturing techniques and materials.

The material of construction is preferably selected according to the performance and biological characteristics desired. For example, the endoprosthesis of the invention can be made to be expanded by the change of a delivery condition, such as by the removal of a restraint or exposure to the environment within the body lumen, so as to be self expanding, or by the application of an external force or energy, such as by a balloon or by a radio frequency. For purpose of illustration and not limitation, reference is made generally to "self-expanding" embodiments and "balloon expandable" embodiments of the endoprosthesis of the present invention.

Self-expanding embodiments can be made from any of a variety of known suitable materials including super elastic or shape memory materials, such as nickel-titanium (NiTi) alloys, Elgiloy, and suitable polymers, such as suitable shape memory polyurethane copolymers, or any equivalents thereof. An endoprosthesis made of a suitable super elastic material can be compressed or restrained in its delivery configuration on a delivery device using a sheath or similar restraint, and then deployed to its deployed configuration at a desired location by removal of the restraint as is known in the art. An endoprosthesis made of shape memory material generally can be delivered in a like manner, and if thermally sensitive, can be deployed by exposure of the endoprosthesis to a sufficient temperature to facilitate expansion as is known in the art. It also is possible to make the self-expanding embodiment of a biocompatible material capable of expansion upon exposure to the environment within the body lumen, such as a suitable hydrogel or hydrophilic polymer, including biodegradable or bioabsorbable polymers, such as polycaprolactone (PCL), poly-D,L-lactic acid, Poly-L-lactic acid, poly (lactide-co-

glycolide), poly(hydroxybutyrate), polyanhydrides, poly(glycolic acid). For example, if made of an expandable hydrophilic material, the endoprosthesis can be delivered to the desired location in an isolated state, and then exposed to the aqueous environment of the body lumen to facilitate expansion. Alternative known delivery devices and techniques for a self-expanding endoprosthesis likewise can be used. Prior to crimping of the self-expanding endoprosthesis for loading into a delivery system, the endoprosthesis may be coated with a lubricant such as silicone oil to reduce force between the endoprosthesis and the crimping device and additionally to reduce forces of disposing the endoprosthesis in a delivery device. Additionally, the lubricant may reduce deployment force thereby increasing accuracy of endoprosthesis placement within a patient. The lubricant may be introduced prior to, during, or after the crimping or loading process.

It is further contemplated that the markers in accordance with the present invention may improve the deliverability of a self-expanding endoprosthesis when used with a movable sheath delivery system. The markers projecting above the outer surface of the tubular body of the endoprosthesis contact the sheath of the delivery system and hold the sheath above the surface of the endoprosthesis, thereby reducing friction between the sheath and the endoprosthesis. Additionally, by having point contact between the sheath and the endoprosthesis it is possible the system may be more flexible and thus have better delivery characteristics compared to a similar system where the sheath is in continuous contact with the endoprosthesis. In addition to providing improved deliverability, it is contemplated that by having the markers protrude about the surface of the endoprosthesis this may provide less trauma to the tissue surrounding the endoprosthesis after delivery of the endoprosthesis by holding the surface of the endoprosthesis off the tissue and providing only points of contact.

Balloon expandable embodiments or the like can be made of any of a variety of known suitable deformable materials, including stainless steel, silver, platinum, cobalt chromium alloys such as L605, MP35N or MP20N or any equivalents thereof. "L605" is understood to be a trade name for an alloy available from UTI Corporation of Collegeville, Pennsylvania, including about 53% cobalt, 20% chromium and 10% nickel. "MP35N" and "MP20N" are understood to be trade names for alloys of cobalt, nickel, chromium and molybdenum available from Standard Press Steel Co., Jenkintown, PA. MP35N generally includes about 35% cobalt, 35% nickel, 20% chromium, and 10% molybdenum. MP20N generally

includes about 50% cobalt, 20% nickel, 20% chromium and 10% molybdenum. For delivery, the endoprosthesis of a suitable material is mounted in the delivery configuration on a balloon or similar expandable member of a delivery device. Once properly positioned within the body lumen at a desired location, the expandable member is expanded to expand the endoprosthesis to its deployed configuration as is known in the art. Additionally, or alternatively, balloon expandable embodiments can be made of suitable biocompatible polymers, including biodegradable or bioabsorbable materials, which are either plastically deformable or capable of being set in the deployed configuration. If plastically deformable, the material is selected to allow the endoprosthesis to be expanded in a similar manner using an expandable member so as to have sufficient radial strength and scaffolding and also to minimize recoil once expanded. If the polymer must be set in the deployed configuration, the expandable member can be provided with a heat source or infusion ports to provide the required catalyst to set or cure the polymer. Alternative known delivery devices and techniques for a self-expanding endoprosthesis likewise can be used.

Additional materials or compounds also can be incorporated into or on the endoprosthesis if desired. For example, the endoprosthesis can be provided with one or more coatings of biocompatible material to enhance the biocompatibility of the device. Such coatings can include hydrogels, hydrophilic and/or hydrophobic compounds, and polypeptides, proteins or amino acids or the like, including poly vinyl pyrrolidone (PVP), poly vinyl alcohol (PVA), parylene, and heparin. A preferred coating material includes phosphorylcholine, as disclosed in U.S. Patent Nos. 5,705,583 and 6,090,901 to Bowers et al. and U.S. Patent No. 6,083,257 to Taylor et al., each of which is incorporated by reference herein. Such coatings can also be provided on the endoprosthesis to facilitate the loading or delivery of beneficial agents or drugs, such as therapeutic agents, pharmaceuticals and radiation therapies. Alternatively, the surface of the endoprosthesis can be porous or include one or more reservoirs or cavities formed therein to retain beneficial agent or drug therein as is known in the art. For purposes of illustration and not limitation, the drug or beneficial agent can include antithrombotics, anticoagulants, antiplatelet agents, thrombolytics, antiproliferatives, anti-inflammatories, agents that inhibit hyperplasia, inhibitors of smooth muscle proliferation, antibiotics, growth factor inhibitors, or cell adhesion inhibitors, as well as antineoplastics, antimetotics, antifibrins, antioxidants, agents that promote endothelial cell recovery, antiallergic substances, radiopaque

agents, viral vectors, antisense compounds, oligonucleotides, cell permeation enhancers, and combinations thereof.

The endoprosthesis can also be provided with coverings, such as PTFE, ePTFE, Dacron, woven materials, cut filaments, porous membranes, harvested
5 vessels and/or arteries, or others such materials to form a stent graft prosthesis. Similarly, a medical device, such as a valve, a flow regulator or monitor device, can be attached to the endoprosthesis, such that the endoprosthesis functions as an anchor for the medical device within the body lumen.

Additionally, an imaging compound or radiopaque material can be
10 incorporated with the endoprosthesis. For example, one or more of the annular elements of the endoprosthesis can be made of a suitable radiopaque material, such as gold, tantalum or a similar material. Alternatively, the radiopaque material can be applied on selected surfaces of one or more of the annular elements using any of a variety of known techniques, including cladding, bonding, adhesion, fusion,
15 deposition or the like. In a preferred embodiment, the material used for fabrication of the endoprosthesis includes a composite structure having multilayers of different materials or compositions. Generally, at least one layer is a base material such as stainless steel, nickel-titanium alloy or cobalt chromium alloy to impart the intended structural characteristic of the endoprosthesis, and at least another layer is a
20 radiopaque material such as gold or tantalum for imaging purposes. For example, a tri-layer structure of 316L-Ta-316L is preferred for a balloon expandable stent and a tri-layer structure of NiTi-Ta-NiTi is preferred for a self-expanding stent. Suitable multi-layered composite structures are available in sheet or tube form from UTI Corporation of Collegeville, Pennsylvania, and are disclosed in US Patent No.
25 5,858,556, which is incorporated herein by reference. In yet another embodiment, one or more marker elements of radiopaque material can be attached to the endoprosthesis. For example, and as previously shown in Fig. 25, eyelets or tabs can be provided on one or more annular elements, preferably at at least a distal or proximal longitudinal end of the endoprosthesis. A rivet or bead of radiopaque
30 material can then be attached to the eyelet or tab in a manner as known in the art. Alternatively, the separate marker can be attached directly to annular element. For example, and in accordance with a preferred embodiment of the invention as shown in Figs. 1 and 15, a wire or strip of radiopaque material can be wrapped around and secured to a base portion of one or more foot extensions at one or both longitudinal

ends of the endoprosthesis; preferably by providing the foot extension with a geometry to enable limited strain in the base portion of the foot extension upon deployment.

A variety of manufacturing techniques are well known and may be used for fabrication of the endoprosthesis of the present invention. For example, and in a preferred embodiment, the endoprosthesis can be formed from a hollow tube of suitable material using a known technique, such as by laser cutting, milling or chemical etching. The structure is mechanically blasted with a media and then electropolished or otherwise finished to remove burrs and eliminate sharp edges and contaminates. An additional de-scaling process may be performed after electropolishing, wherein the de-scaling process involves the use of an acid bath. Alternatively, the endoprosthesis can be fabricated from a sheet of suitable material using a similar cutting, milling or etching technique, and then rolled or bent about a longitudinal axis into the desired shape. If desired, the lateral edges of the structure can be joined together, such as by welding or bonding, to form a closed tubular structure, or the lateral edges can remain unattached to form an coiled, rolled sheet or open tubular structure. Conversely, a suitable material of construction can be applied selectively to a substrate to define the desired pattern of the endoprosthesis structure, and then the substrate can be removed. Other methods of manufacture also can be used for the endoprosthesis of the present invention, such as by bending toroidal rings or elongate lengths of wire into appropriately shaped members, such as that corresponding to each annular element, and then joining the appropriately shaped members together at connection locations by a welding or bonding technique or the like. If a shape memory material is used, such as a nickel titanium alloy, the fabricated structure can be heat treated on a mandrel or the like using known techniques to establish the desired endoprosthesis shape and dimensions at a predetermined temperature, e.g. when above austenitic transition temperature.

An additional step of passivation may be performed during the manufacturing stage of the endoprosthesis in order to form a homogeneous oxide layer for corrosion resistance. The passivation process may be performed prior to installation of the markers in accordance with the present invention or it may be performed after installation of the markers. Alternatively, multiple passivation processes may be performed, once prior to insertion of the markers and again after insertion of the markers.

As originally cut or fabricated, the endoprosthesis can correspond to its delivery configuration or to a deployed configuration or a configuration therebetween. In this manner, the endoprosthesis can be crimped or otherwise compressed into its delivery configuration on a corresponding delivery device. In another preferred
5 embodiment, the endoprosthesis is originally fabricated from a tube having a diameter corresponding to the deployed configuration. In this manner, the longitudinally-free portions of the annular elements (*e.g.*, apices not at a connection location) and circumferentially-free portions (*e.g.*, the toe portion of the foot extensions) can be maintained within the general cylindrical shape (*e.g.*, diameter) of the endoprosthesis
10 when deployed, so as to avoid such portions from extending radially inwardly when in the deployed configuration. The endoprosthesis is therefore designed to match the target vessel in which the endoprosthesis is to be deployed. For example a stent will typically be provided with an outer diameter in the deployed configuration ranging from about 1 mm for neurological vessels to about 25 mm for the aorta. Similarly, a
15 stent will typically be provided with a length ranging from 5 mm to 300 mm. Variations of these dimensions will be understood in the art based upon the intended application or indication for the endoprosthesis.

As previously noted, the geometry of each component of the endoprosthesis, such as the width, thickness, length and shape of the strut members
20 and foot portions, as well as of the connectors if provided, is preferably selected to obtain predetermined expansion, flexibility, foreshortening, coverage scaffolding, and cross profile characteristics. For example, longer strut members can promote greater radial expansion or scaffolding coverage. The phase difference or circumferential alignment between adjacent annular elements likewise can be altered to control
25 coverage and flexibility as well as facilitate more uniform drug delivery. Similarly, the number and placement of connection locations and, if present, the connectors, between longitudinally-adjacent annular elements are preferably selected to obtain the desired flexibility of the endoprosthesis. The number of apices and foot
30 extensions between connection locations also can be varied to achieve desired performance characteristics. Fig. 22 depicts a representative embodiment depicting such variations within an endoprosthesis of strut lengths and strut widths for varied rigidity, and of connector locations for varied flexibility.

As recognized from the detailed description above, the foot extensions particularly enhance and provide versatility in the design of the endoprosthesis of the

present invention. The foot extension can be configured and dimensioned relative to the strut members and the remainder of the endoprosthesis to compensate for longitudinal foreshortening upon stent expansion. For example, the areas of flexure of the foot extensions can be adjusted by contouring the foot geometry and dimensions, as well as by altering the lengths of selected strut members. Alternatively, the geometry of the foot extension can be configured to provide a desired amount of lengthening or shortening of the endoprosthesis upon expansion. The foot extensions can be configured to balance or assist in evenly distributing strain or expansion of the endoprosthesis. The foot extensions also can improve and control the flexibility of the endoprosthesis, preferably without substantially impacting the desired coverage or scaffolding of the endoprosthesis. The circumferentially elongated base portion of each foot extension provides a wide range of connection locations, and allows adjacent annular elements to be attached over a range of phase differences or circumferential alignment. The foot extensions can be configured to produce a torque on longitudinally free portions, such as unconnected apices, to maintain these longitudinally free portions within the general cross profile of the endoprosthesis when flexed along its longitudinal axis or expanded to its deployed configuration. This feature can be adjusted if it is desired to embed portions of the endoprosthesis into the vessel wall or other tissue.

Reference is now made to two exemplary preferred embodiments of a stent of the present invention; a self-expanding stent as shown in Figs. 23a through 23f, and a balloon expandable stent as shown in Figs. 24a through 24f.

Fig. 23a shows the planar format of a preferred embodiment of a self-expanding stent as cut and polished in a slightly deployed configuration. As depicted herein, the self-expanding stent comprises ten annular elements with five connection locations between longitudinally-adjacent annular elements for an approximate stent length of about 21 mm. Annular elements can be added to increase the stent length, or omitted to decrease the stent length, as desired. Each annular element includes fifteen apices per longitudinal side. On one longitudinal side of each annular element, five apices are defined by foot extensions. Two circumferentially-adjacent apices are located between adjacent foot extensions. On the other longitudinal side of each annular element, no foot extensions are provided. Each foot extension has a shape similar to that of Fig. 2c, as previously described in detail. Each of the five connection locations between adjacent annular

elements 10 is defined by a slightly overlapping pattern of the base portion 46 of each foot extension 40 with a corresponding apex 30 of a longitudinally-adjacent annular element in a manner similar to that of Fig. 21a. In this manner, longitudinally-adjacent apices of adjacent annular elements are out of circumferential alignment with each other so as to be less than 180 degrees out of phase. Furthermore, connection locations 50 are circumferentially displaced or offset from one set of annular elements to the next.

The self-expanding stent of this preferred embodiment is made from a suitable tube stock of nickel-titanium alloy, such as SE508 or SM508, ASTM Standard F2063-00, comprising about 54.5 to about 57% wt. nickel and about 45.5 to about 42.7% wt. titanium, which is commercially available from Minitubes, Inc. of Grenoble, France. It is recognized, however, that alternative alloy compositions can be used if desired. For fabrication of a self-expanding stent having a deployed configuration diameter of about 7 mm to about 8 mm, the tube stock has an outer diameter of about 0.091 inch and a uniform wall thickness of about 0.010 inch. The tube stock is laser cut with the configuration shown in Fig. 23b as a continuous pattern around the circumference of the tube; wherein only the front half of the structure is shown for clarity. The cut tube is then mechanical blast and sequentially heat treated on a series of cylindrical mandrels of increasing diameter using known techniques to set the desired deployed configuration of the stent when in an austenitic state as shown in Fig. 23d. The heat set stent is then electropolished using known techniques. The relevant dimensions of the strut members for this preferred embodiment, after electropolishing, include a nominal strut length of about 0.055 inch, a nominal strut width of about 0.004 inches and a generally uniform thickness of about 0.008 inches. Regarding each foot extension, after electropolishing, the first portion of the foot extension has a width of about 0.005 inch and a length of about 0.013, as measured along its outer edge, and the base portion of the foot extension includes total length of about 0.033, as measured along its outer edge, with a first portion proximate the heel portion having a width of about 0.005 inch and a second portion proximate the toe portion having a width of about 0.007 inch. The strut member extending from the ankle portion of the foot extension tapers from a width of about 0.005 inch at the end proximate the foot extension to about 0.004 inch at the opposite end, with a length of about 0.059 inch. The strut member extending from the heel portion of the foot extension tapers from a width of about 0.005 inch at the end

proximate the foot extension to about 0.004 inch at the opposite end, with a length of about 0.068 inch. After polishing, additional cleaning or preparation may be required.

Once prepared, the self-expanding stent of this embodiment is compressed to a delivery configuration as shown in the front-half view of Fig. 23c, preferably with the strut members generally parallel to the longitudinal axis of the stent and each other. The stent can then be delivered using a conventional retractable sheath delivery catheter, as is known in the art. Figs. 23d and 23e show the self-expanding stent of this embodiment in a deployed configuration. For purpose of clarity, only the front half of the stent is shown in Fig. 23d. As depicted, the stent of this embodiment has been balanced for generally uniform expansion. Fig. 23f shows a self-expanding stent of greater length of this embodiment deployed in a curved vessel, wherein the apices proximate the inner radius of the curve generally open less than the apices proximate the outer radius of the curve.

Fig. 24a shows the planar format of a preferred embodiment of a balloon expandable stent as cut and polished in a slightly deployed configuration. As depicted herein, the balloon expandable stent comprises fifteen annular elements with two connection locations between longitudinally-adjacent annular elements for an approximate stent length of about 18 mm. Annular elements can be added to increase the stent length, or omitted to decrease the stent length, as desired. Each annular element includes ten apices per longitudinal side. On one longitudinal side of each annular element, two apices are defined by foot extensions. Four circumferentially-adjacent apices are located between adjacent foot extensions. On the other longitudinal side of each annular element, no foot extensions are provided. Each foot extension has a shape similar to that of Fig. 2a, as previously described in detail. Each of the two connection locations between adjacent annular elements is defined by an overlapping pattern of the base portion of each foot extension with a corresponding apex of a longitudinally-adjacent annular element in a manner similar to that of Fig. 20. In this manner, longitudinally-adjacent apices of adjacent annular elements are out of circumferential alignment with each other so as to be less than 180 degrees out of phase. Furthermore, connection locations are circumferentially displaced or offset from one set of annular elements to the next.

The balloon expandable stent of this preferred embodiment is made from a suitable tube stock of composite material including an inner layer of 316L

stainless steel, a middle layer of tantalum, and an outer layer of 316L stainless steel, which is available from UTI Corporation of Collegeville, Pennsylvania, and described in US Patent No. 5,858,556; the entirety of which is hereby incorporated by reference. It is recognized, however, that alternative material compositions can be used if
5 desired. For fabrication of a balloon expandable stent having a deployed configuration diameter of about 2.75 mm to about 3.0 mm, the tube stock has an outer diameter of about 0.062 inch and a generally uniform wall thickness of about 0.004 inch, with the tantalum layer constituting between about 3% to about 50% of the wall thickness, and more preferably between about 10% to about 25% of the wall thickness
10 depending upon the intended indication. For example, a coronary stent of this dimension preferably would have a tantalum layer of between about 15% to about 17% of the tube stock thickness. The tube stock is laser cut with the configuration shown in Fig. 24b as a continuous pattern around the circumference of the tube; only seven annular elements are depicted for purpose of clarity. The cut tube is then
15 mechanically blasted and electropolished using known techniques. The relevant dimensions of the strut members for this preferred embodiment, after electropolishing, include a nominal strut length of about 0.036 inches, a nominal strut width of about 0.003 inches and a generally uniform thickness of about 0.003 inches. Regarding each foot extension, after electropolishing, the first portion of the foot extension has a
20 width of about 0.005 inch and a length of about 0.008 inch, as measured along the outer edge, and the base portion of the foot extension has a width of about 0.005 inch and a length of about 0.021 inch as measure along the outer edge. The strut member extending from the ankle portion of the foot extension tapers from a width of about 0.004 inch at the end proximate the foot extension to about 0.003 inch at the opposite
25 end, with a length of about 0.034 inch. The strut member extending from the heel portion of the foot extension tapers from a width of about 0.005 inch at the end proximate the foot extension to about 0.003 inch at the opposite end, with a length of about 0.042 inch. After electro polishing, additional cleaning or preparation may be required.

30 Once prepared, the balloon expandable stent of this embodiment is compressed to a delivery configuration as shown in Fig. 24c, with only seven annular elements depicted for purpose of clarity. Preferably, the strut members are generally parallel to the longitudinal axis of the stent and each other when in the delivery configuration. The stent can then be delivered using a conventional balloon delivery

device, as is known in the art. Preferably, a portion of balloon material of the delivery device is captured in the gap defined by the foot extension and the circumferentially-adjacent strut member. Figs. 24d and 24e show the balloon expandable stent of this embodiment in a deployed configuration; only seven annular elements are depicted
5 for purpose of clarity. For purpose of clarity, only the front half of the stent is shown in Fig. 24d. As depicted, the stent of this embodiment has been balanced for generally uniform expansion. Fig. 24f shows the balloon expandable stent of this embodiment deployed in a curved vessel, wherein the apices proximate the inner radius of the curve generally open less than the apices proximate the outer radius of
10 the curve. It is further contemplated that the endoprosthesis may include eyelets or tabs such as those shown in Fig 10, wherein the eyelets or tabs may be utilized to retain the endoprosthesis onto a balloon delivery device, wherein the balloon material may be received within the eyelet or tab during the crimping and/or heat setting process. Further still, a biocompatible adhesive may be disposed within the eyelet or
15 tab after the endoprosthesis has been crimped onto the balloon delivery device such that the adhesive would releasably affix the endoprosthesis to the surface of the balloon of the balloon delivery device.

While illustrative embodiments of the invention have been disclosed herein, numerous modifications and other embodiments may be devised by those
20 skilled in the art in accordance with the invention. For example, the various features depicted and described in the embodiments herein can be altered or combined to obtain desired endoprosthesis characteristics in accordance with the invention. Therefore, it will be understood that the appended claims are intended to cover all such modifications and embodiments, which are within the spirit and scope of the
25 present invention.

CLAIMS

What is claimed is:

- 5 1. A method for inserting a radiopaque marker in an endoprosthesis, comprising:
- a. fabricating an endoprosthesis having at least one eyelet sized to receive a radiopaque marker therein;
 - b. pre-forming a first head on a radiopaque marker member;
 - c. disposing said marker member within an eyelet of the endoprosthesis,
- 10 wherein said first head projects above a surface of the endoprosthesis; and
- d. forming a second head on a second end of the marker member, said second head projecting above a second surface of the endoprosthesis.
2. The method according to claim 1, wherein said pre-forming step comprises
- 15 placing the marker member in a clamp and using an off-center drill to form said first head.
3. The method according to claim 1, wherein the method of disposing the marker
- 20 within an eyelet further comprises the step of using a pair of pliers to seat the marker within the eyelet.
4. The method according to claim 3, wherein the pliers have a first jaw and a second jaw, wherein the second jaw includes a concave surface.
- 25 5. The method according to claim 4, wherein said concave surface is configured to receive said first head of said marker.
6. The method according to claim 1, wherein the step of forming the second head further comprises the steps of;
- 30 a. inserting said endoprosthesis into a fixture having a receiving member and aligning a marker forming pin with the second end of the marker;
- b. applying a force to the fixture, thereby causing the marker forming pin to deform the second end of the marker and form the second head.

7. The method according to claim 1, wherein the radiopaque marker member is annealed.
8. The method according to claim 7, wherein after annealing the marker has a
5 Rockwell hardness between about 20 and 50.
9. The method according to claim 1, wherein the radiopaque marker member is formed of a material selected from the group consisting of tantalum, silver, gold, stainless steel.
- 10
10. An endoprosthesis for delivery in a body lumen comprising:
a first set of interconnected strut members defining a first annular element, each strut member of the first annular element including a first end and a second end; and
15 a second set of interconnected strut members defining a second annular element, each strut member of the second annular element including a first end and a second end,
the first annular element and the second annular element aligned longitudinally adjacent to each other along a longitudinal axis and connected to each
20 other with a connector at at least one connection location, wherein at least one connector is constructed of a bio-absorbable material.
11. The endoprosthesis of Claim 10, further including a marker housing associated with one of the annular elements and extending from one of the ends.
- 25
12. The endoprosthesis of Claim 11, wherein the marker comprises a rivet.
13. The endoprosthesis of Claim 12, wherein the connector further comprises a non-bio-absorbable material.
- 30
14. The endoprosthesis of Claim 10, wherein the endoprosthesis is fabricated from a material chosen from the group consisting of nitinol, tantalum, stainless steel, cobalt, a composite material.

15. The endoprosthesis of Claim 10, wherein the bio-absorbable connector is constructed of a material chosen from the group consisting of Polyglycolic acid (PGA), Polyhydroxybutyric acid, PolyL-Lactic acid (PLLA), Polydilactidel glycolide, Polydilactid acid, PolyDL lactide-co-gycolide.
- 5
16. The endoprosthesis of Claim 10, wherein one of the annular rings further includes at least one foot extension extending between a pair of circumferentially-adjacent strut members.
- 10
17. The endoprosthesis of Claim 16, wherein the foot extension has a first foot portion extending circumferentially from a first end of one of the circumferentially-adjacent strut members and a second foot portion extending circumferentially from a first end of the other of the circumferentially-adjacent strut members.
- 15
18. The endoprosthesis of Claim 11, wherein the connector comprises a bio-absorbable component and a metallic component.
19. The endoprosthesis of claim 17, wherein the foot extension further includes a modulator member disposed adjacent the first foot portion and the second foot
- 20
20. The endoprosthesis of claim 19, wherein the modulator is constructed of a bio-absorbable material chosen from the group consisting of Polyglycolic acid (PGA), Polyhydroxybutyric acid, PolyL-Lactic acid (PLLA), Polydilactidel glycolide,
- 25
- Polydilactid acid, PolyDL lactide-co-gycolide.

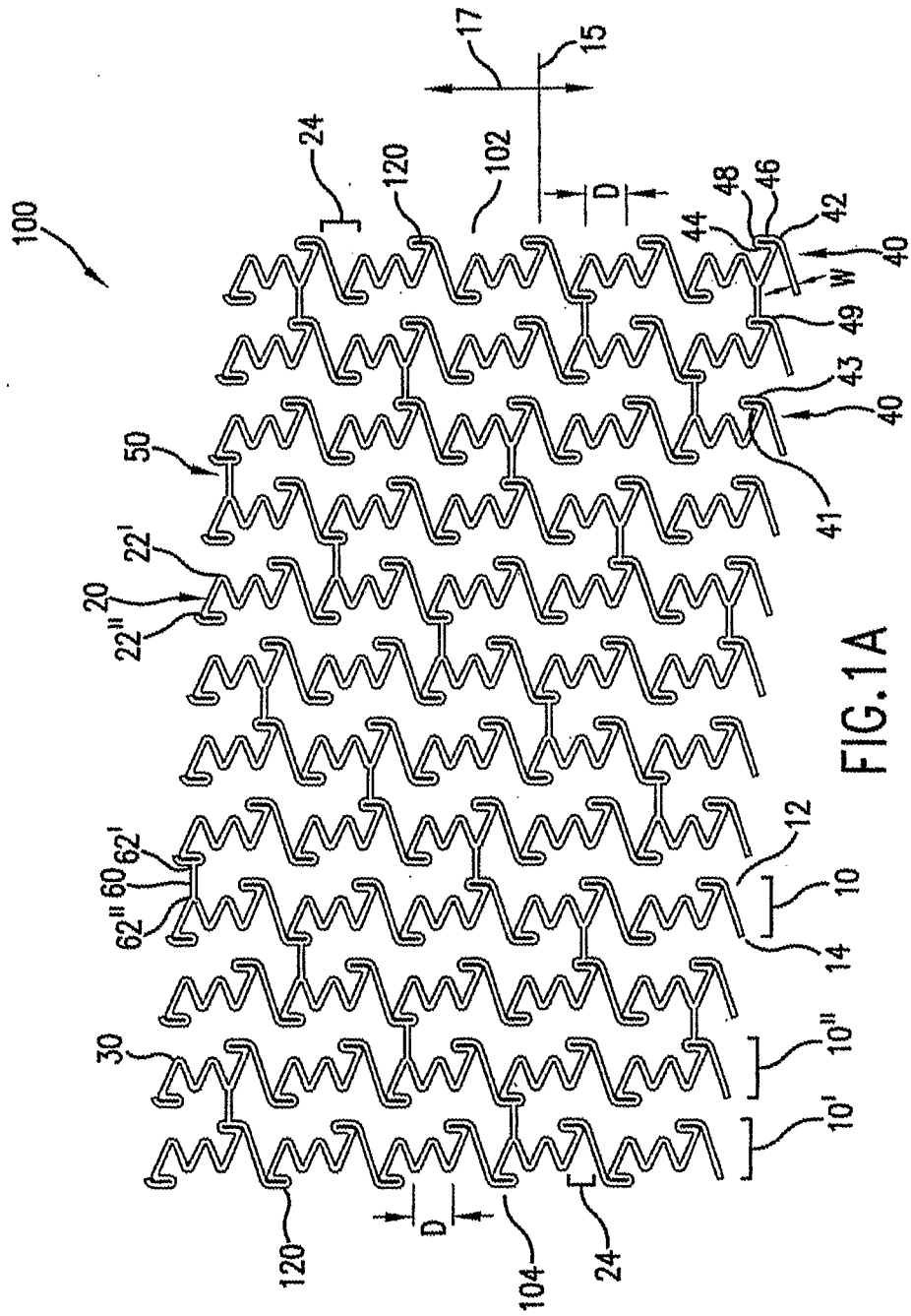

FIG.1A

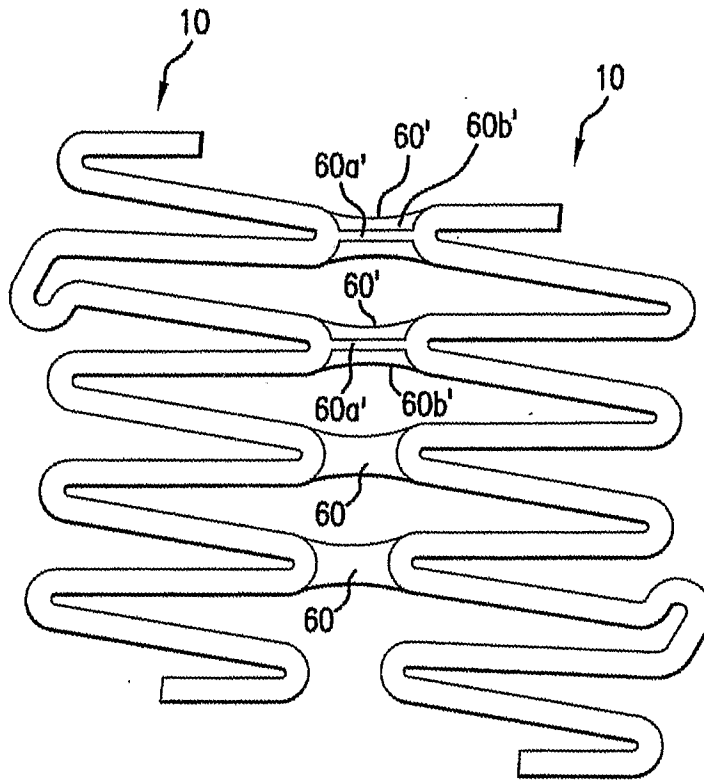

FIG. 1B

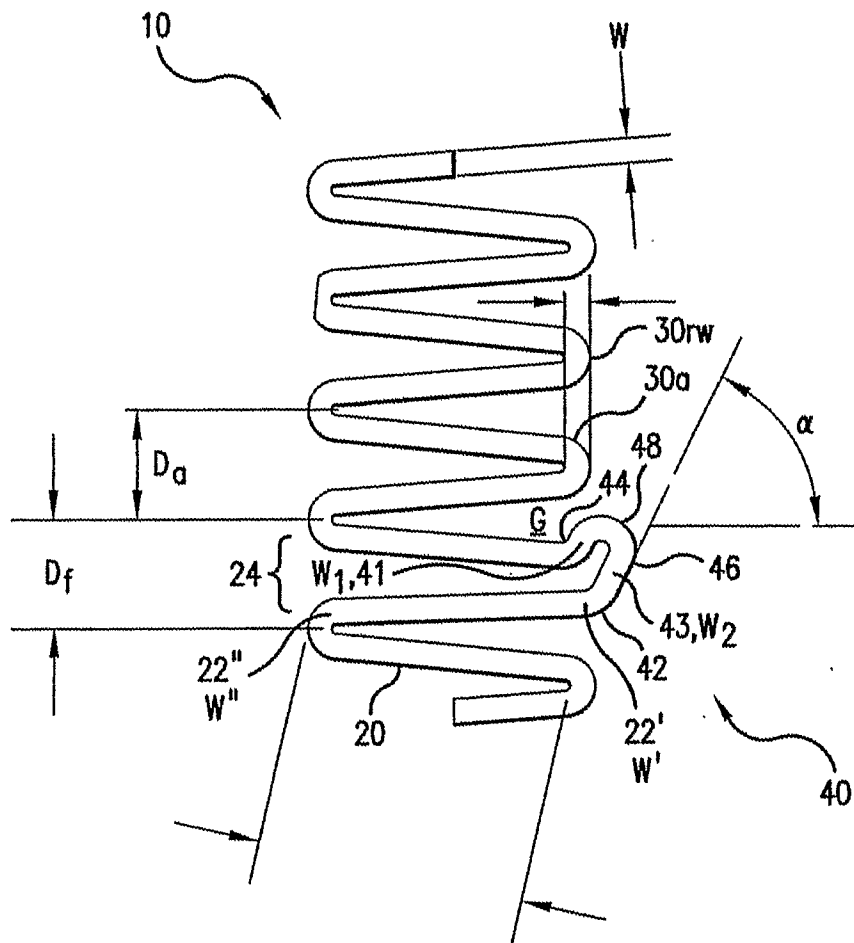

FIG.2A

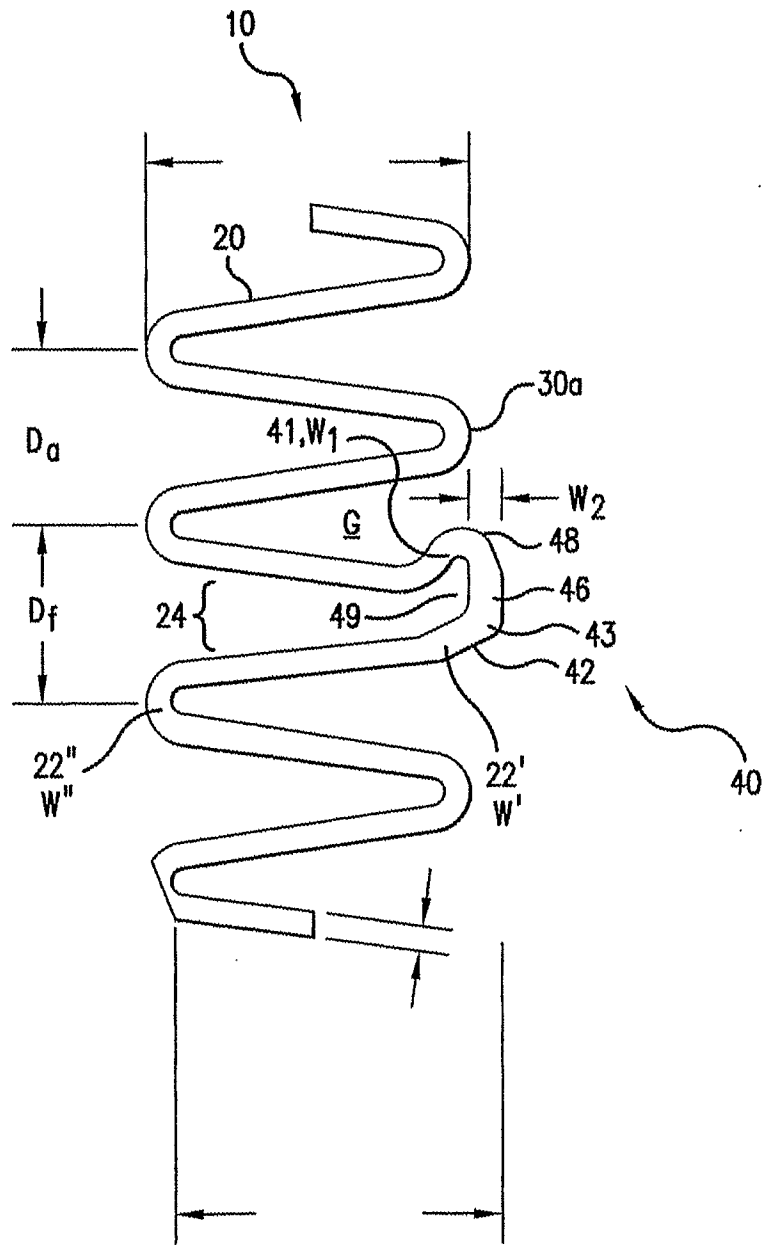

FIG.2B

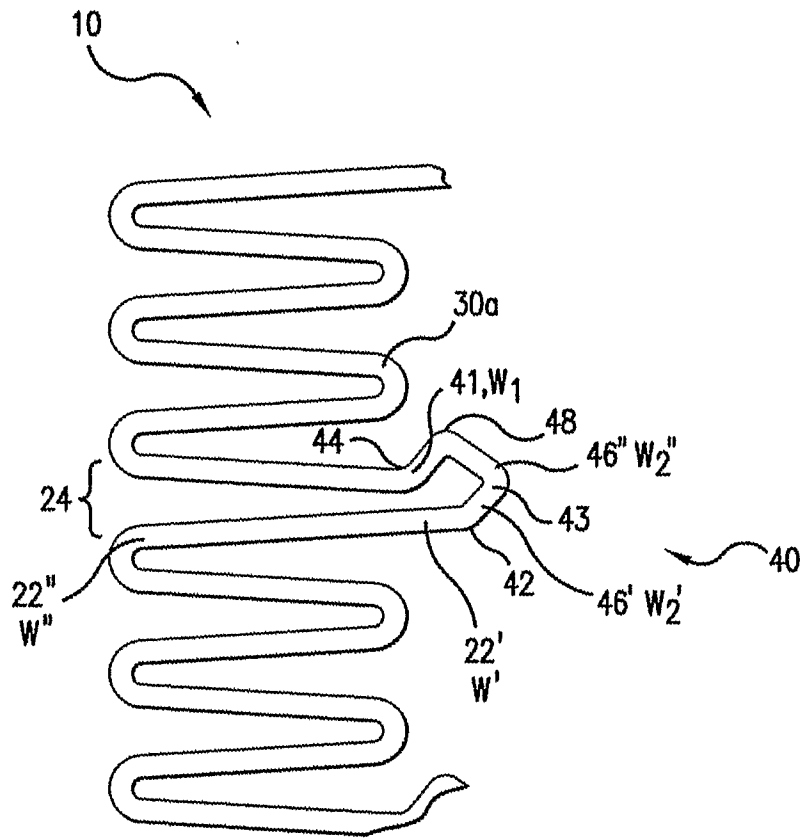

FIG.2C

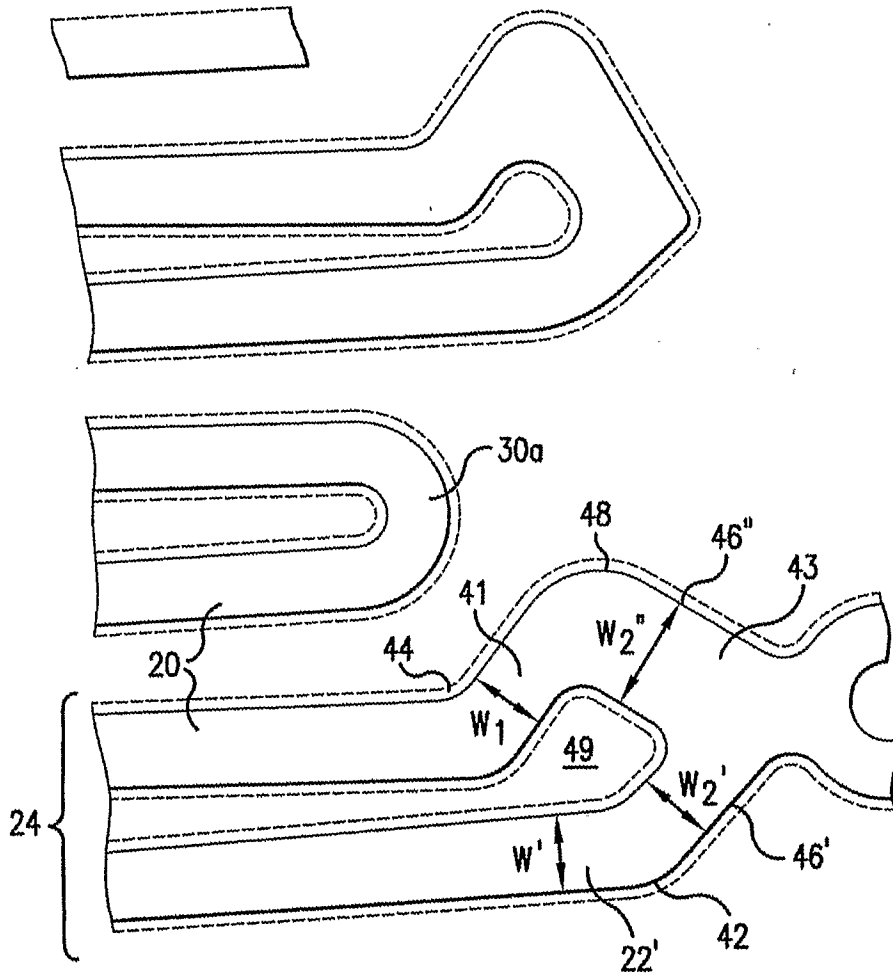

FIG.2D

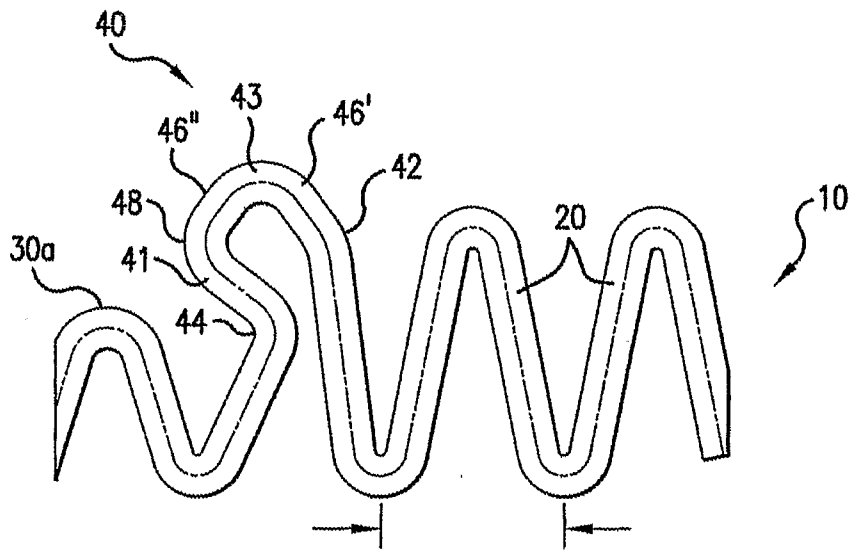

FIG.2E

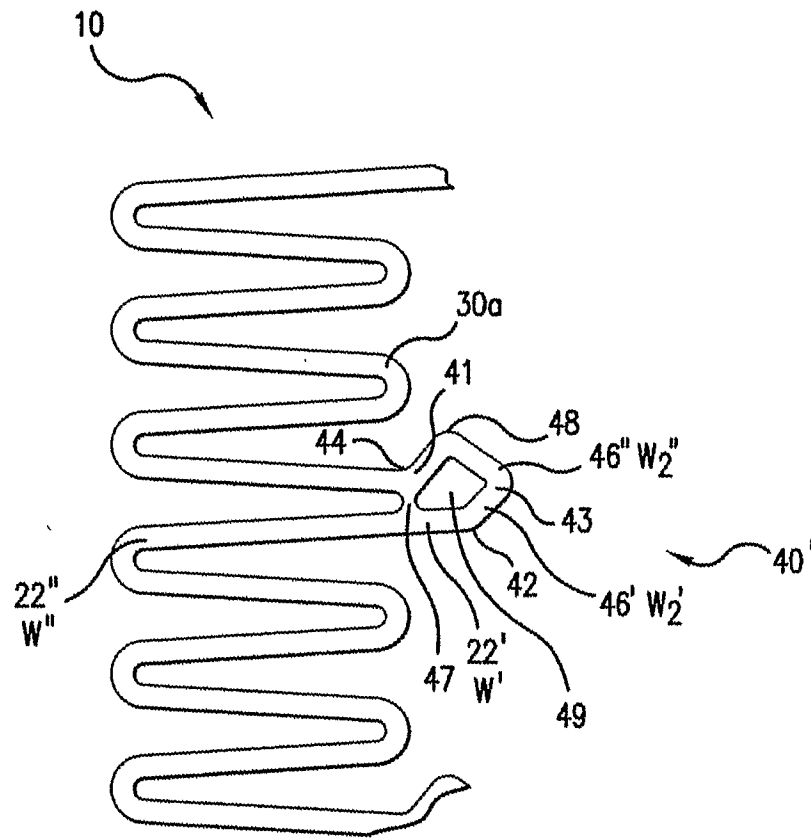

FIG.2F

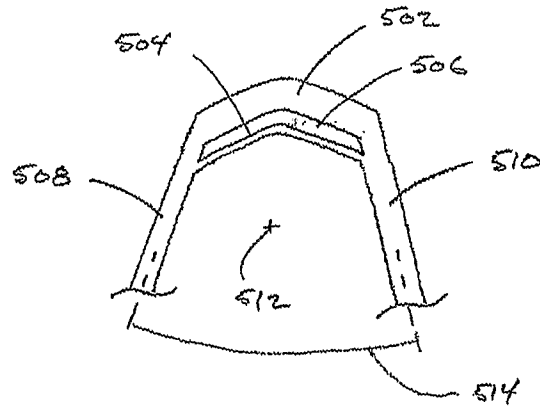

FIG. 2G

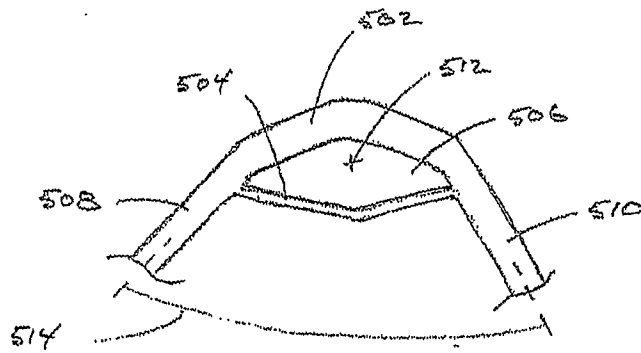

FIG. 2H

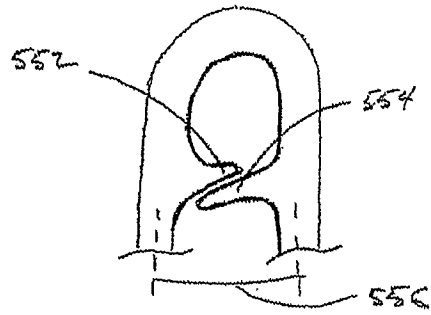

FIG. 2I



FIG. 2J

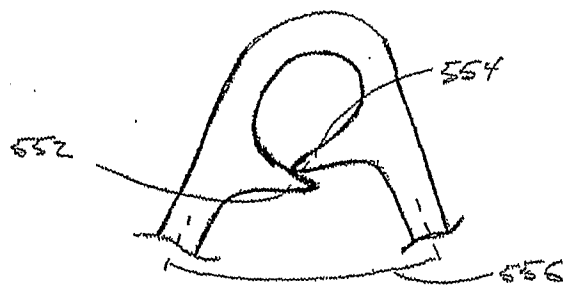

FIG. 2K

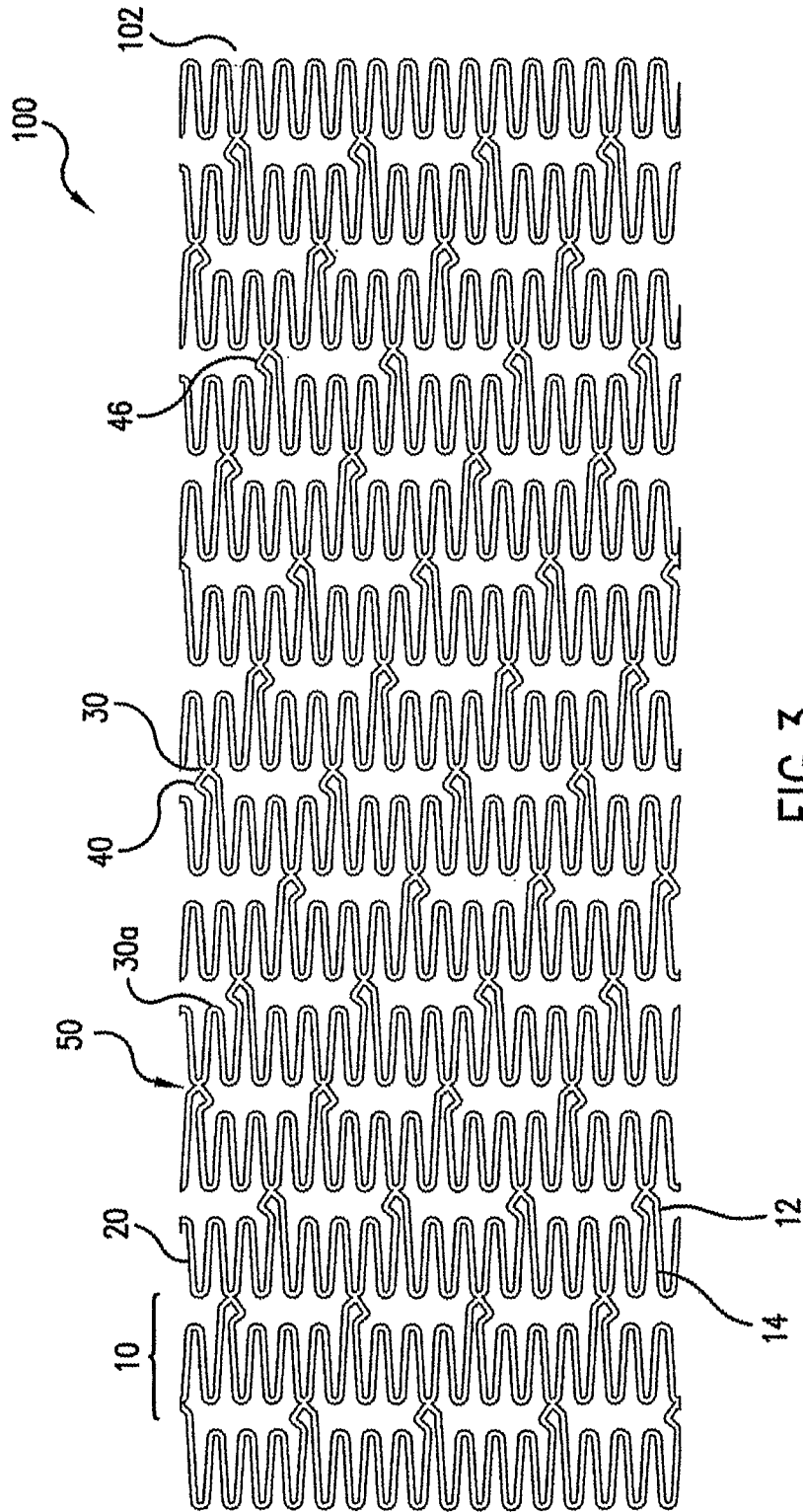

FIG.3

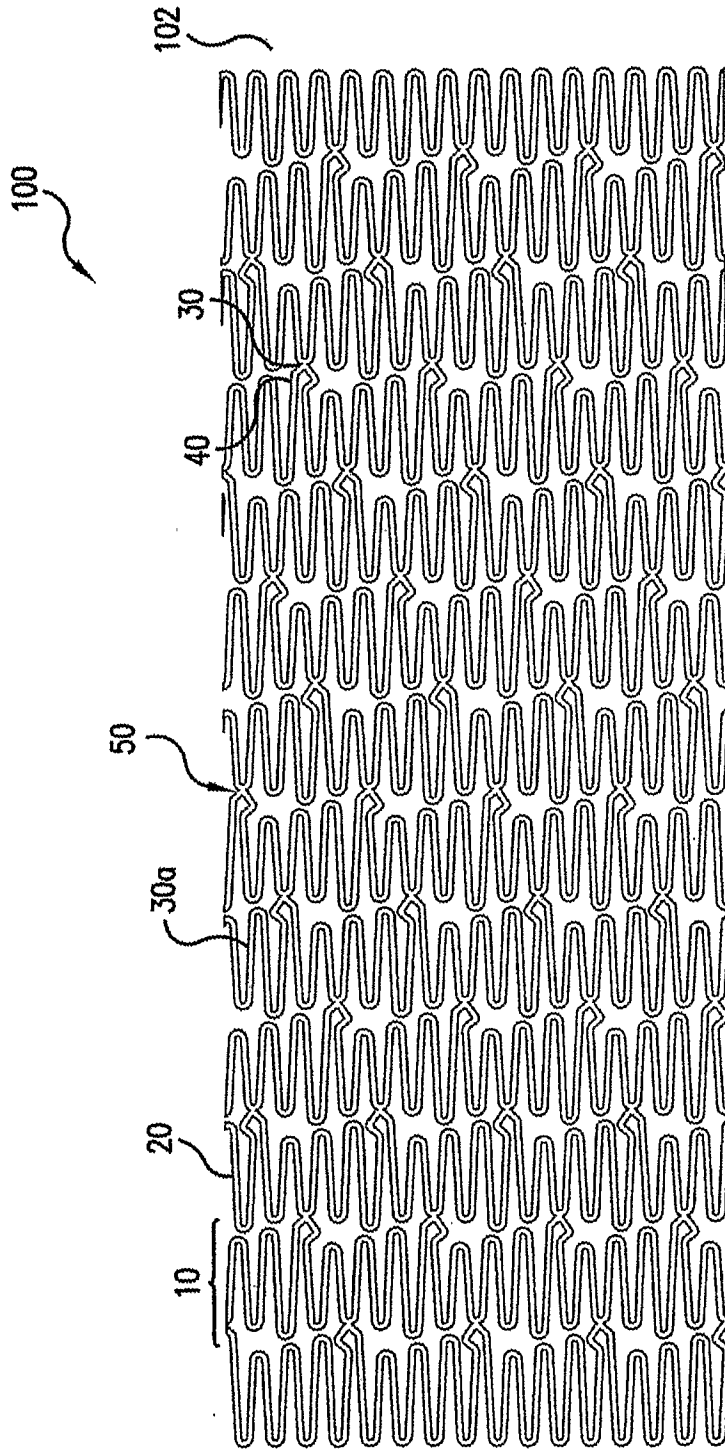

FIG.4

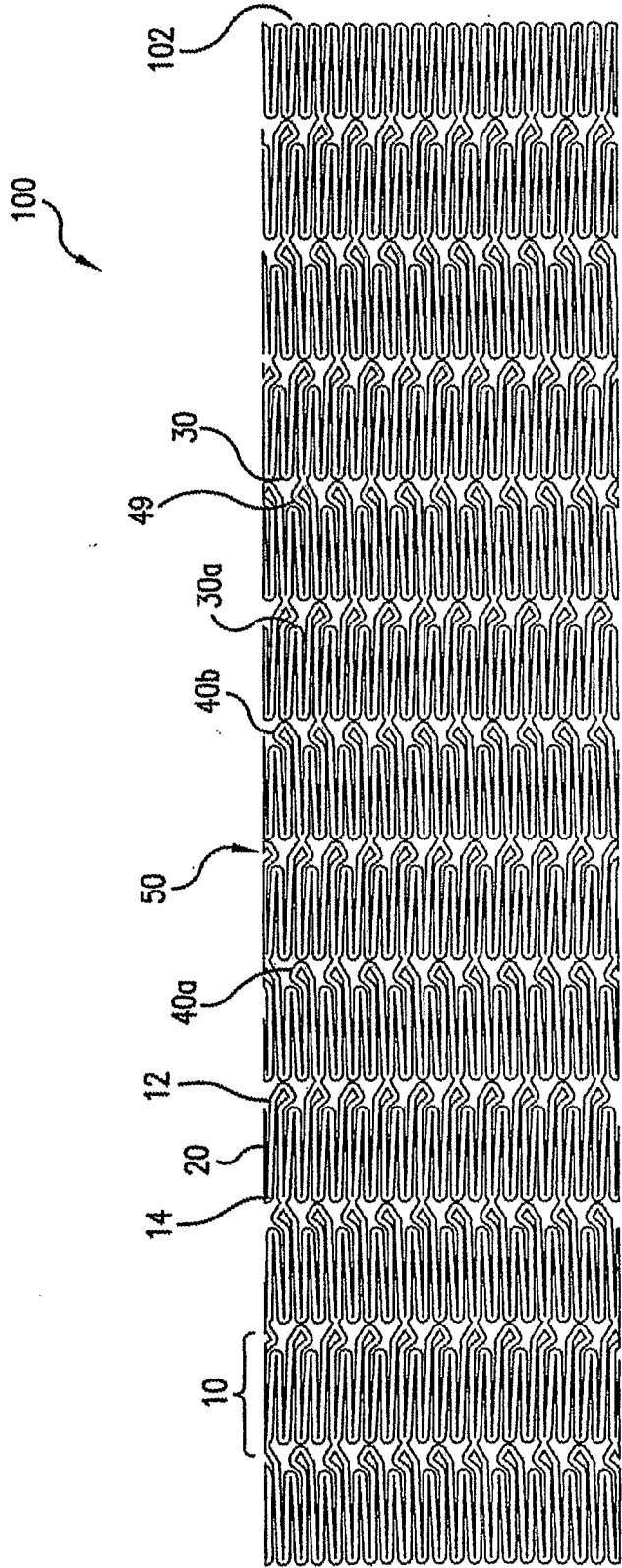

FIG.5

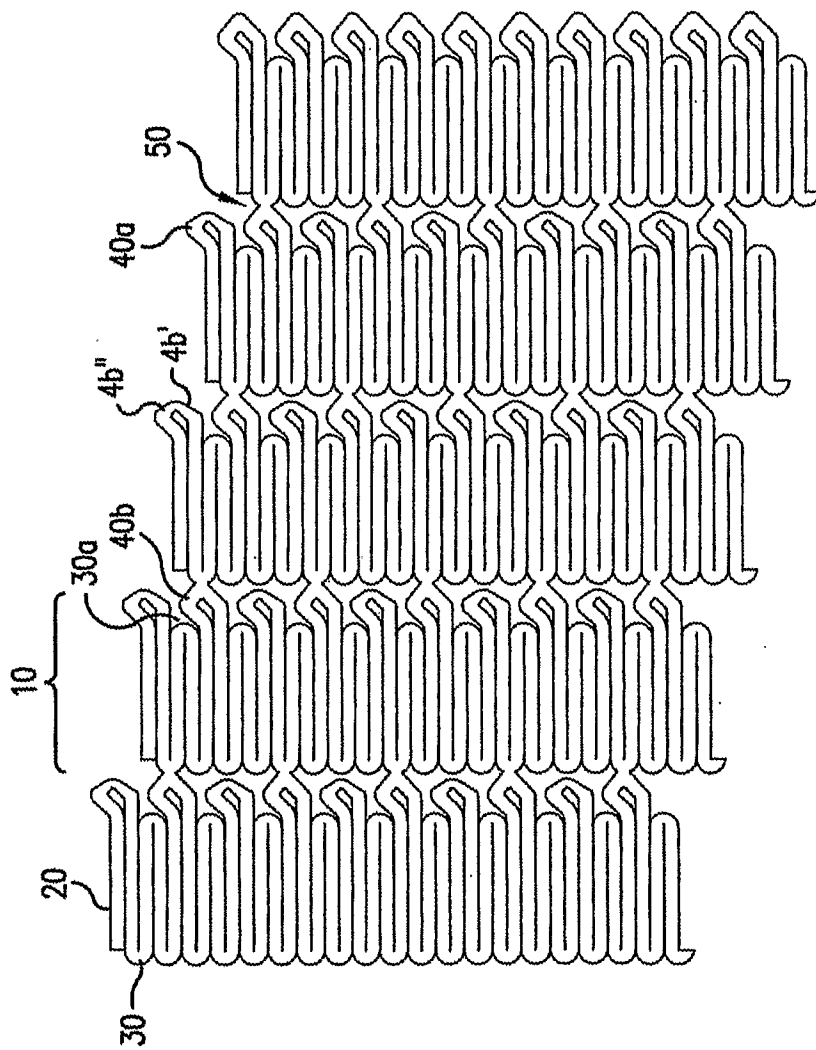

FIG.6

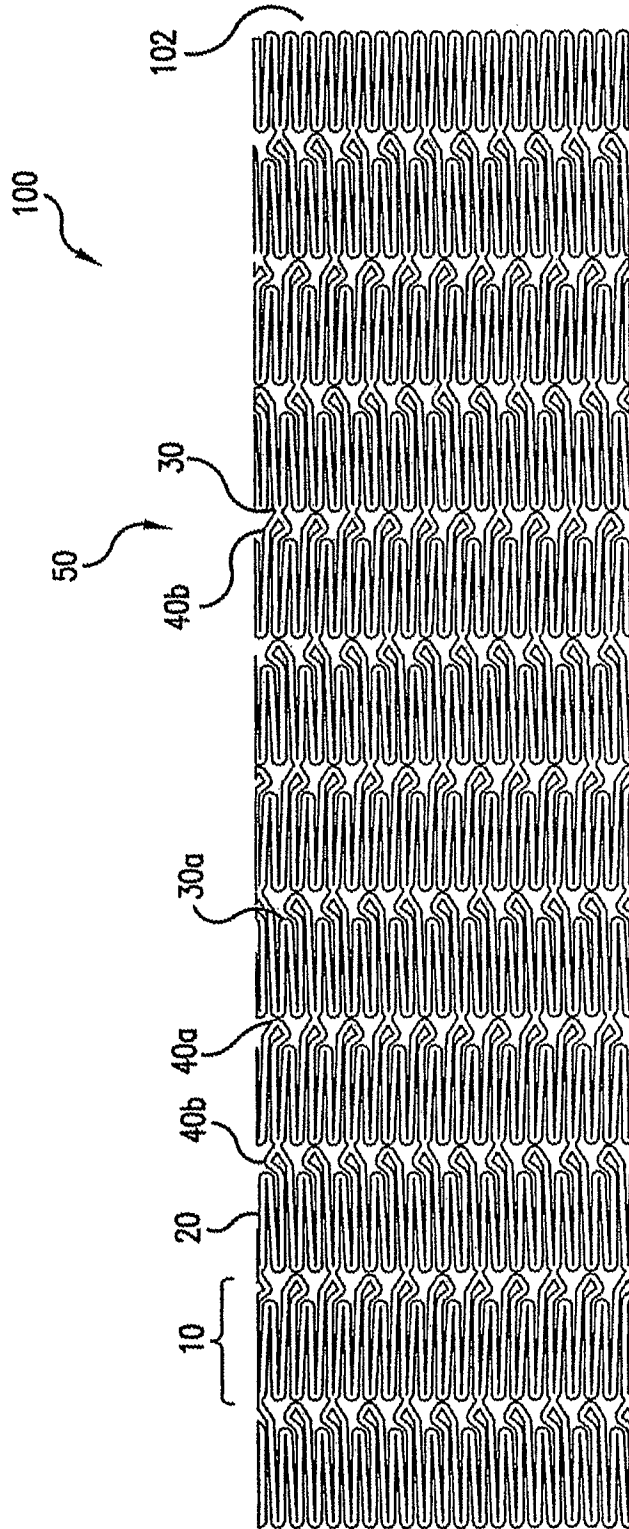

FIG. 7

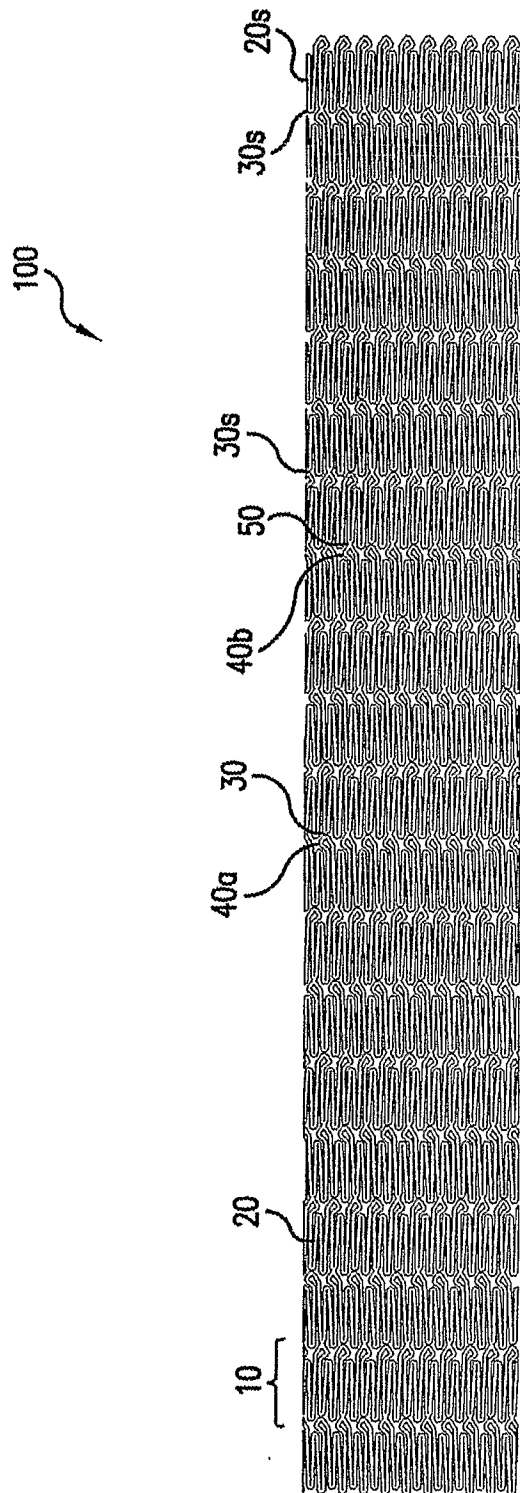

FIG.8

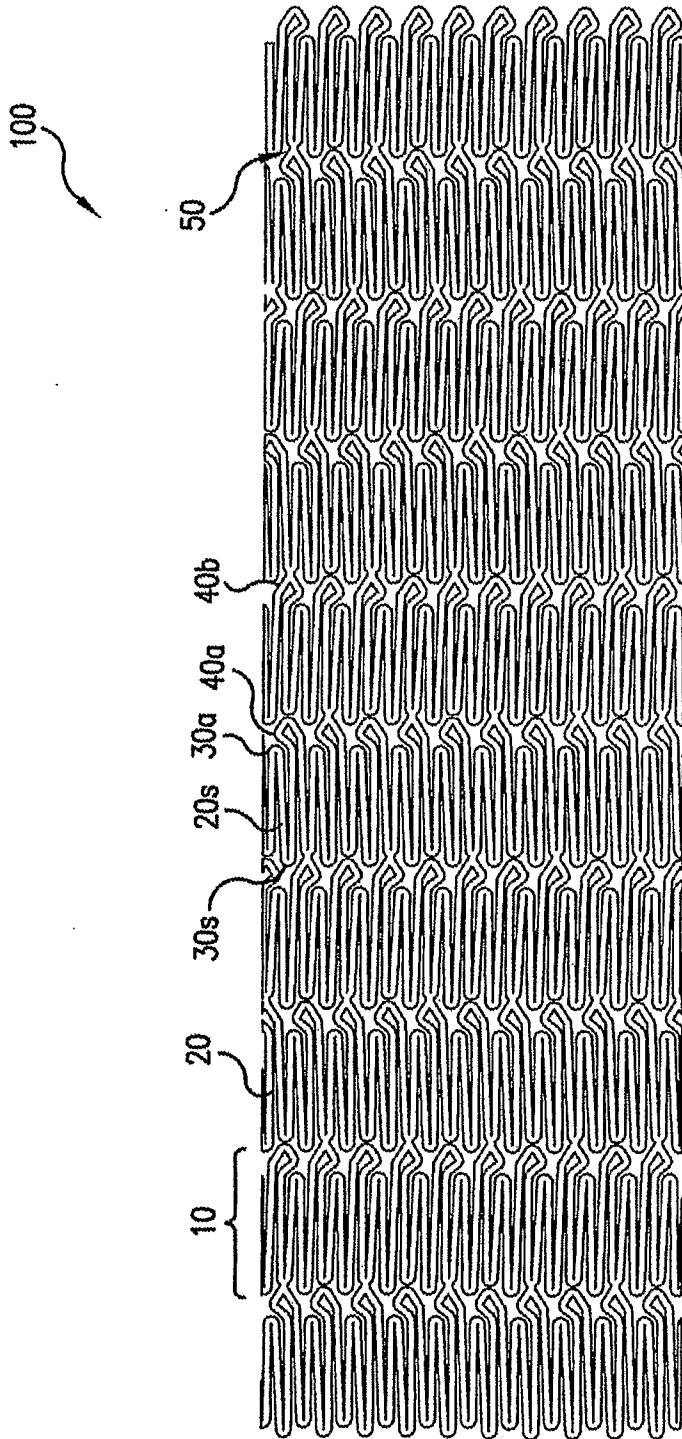

FIG.9

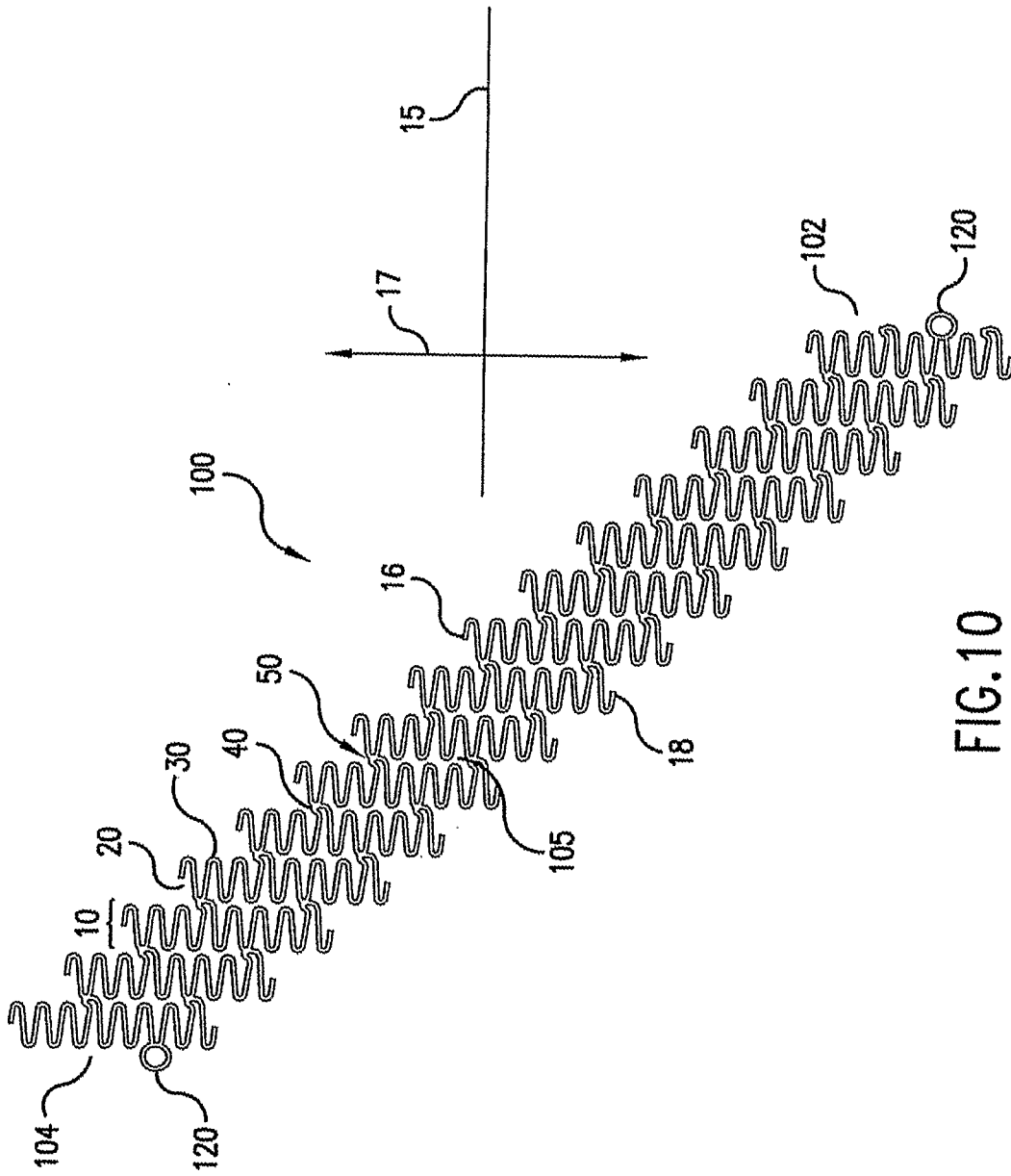

FIG.10

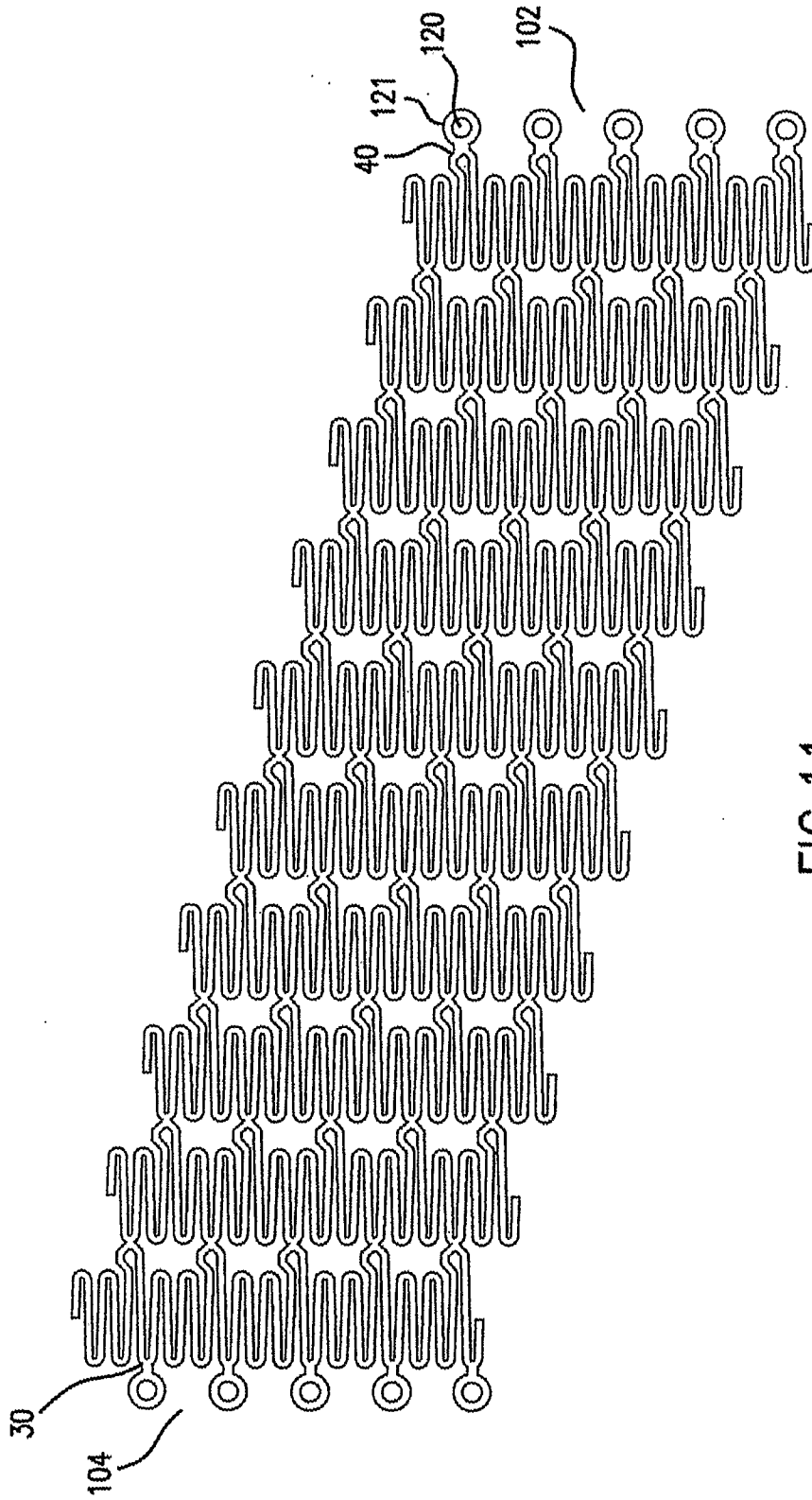

FIG.11

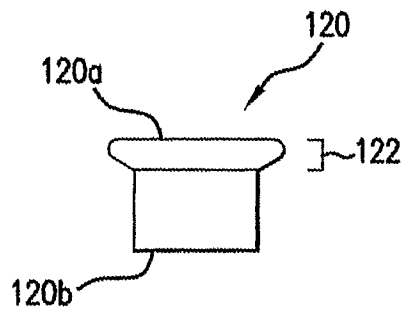

FIG. 12

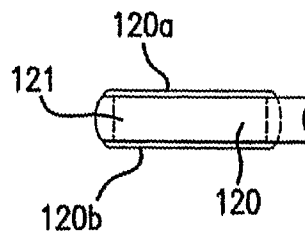

FIG. 13

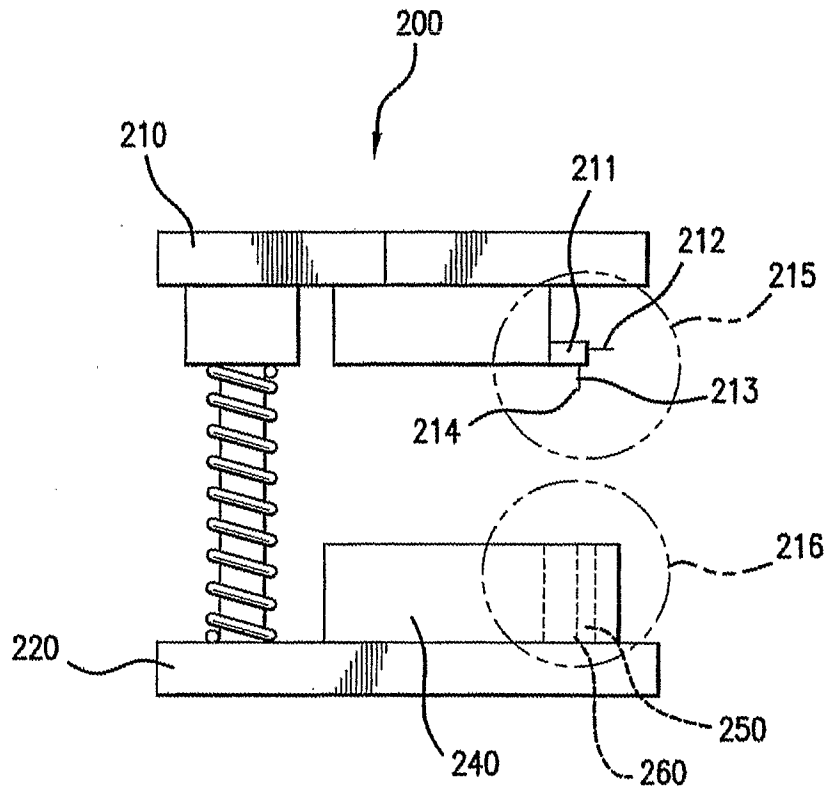

FIG. 14

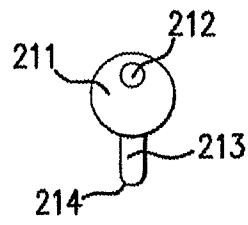

FIG. 15

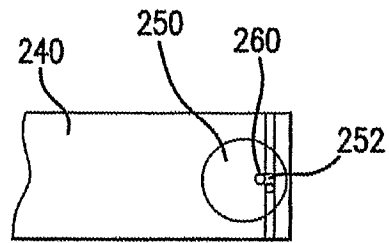

FIG. 16

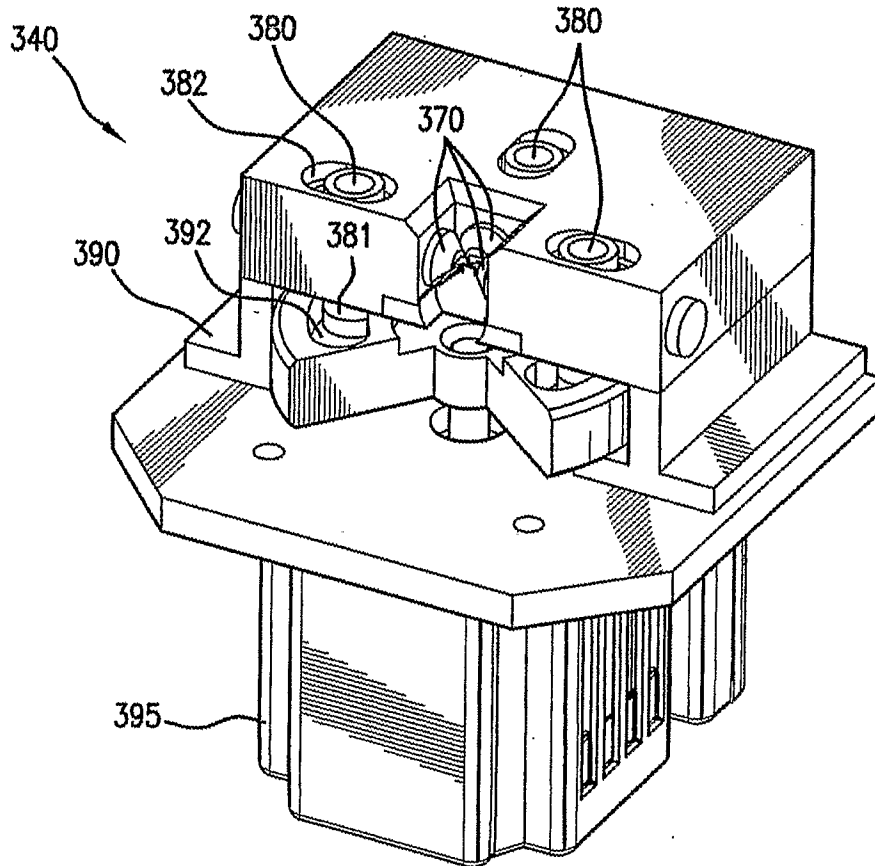

FIG.17

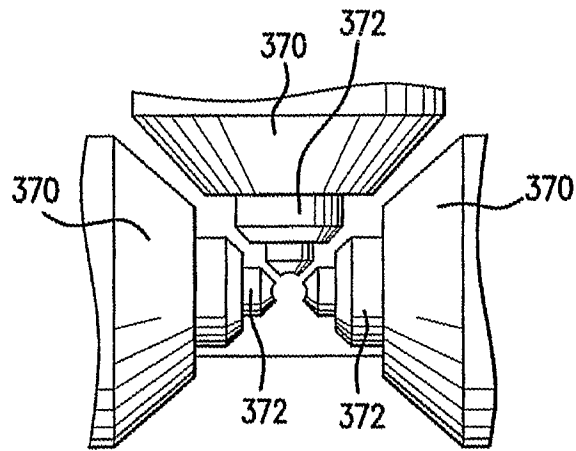

FIG. 18

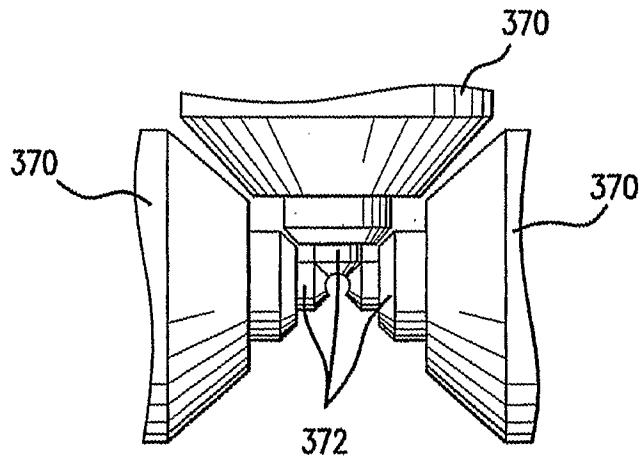

FIG. 19

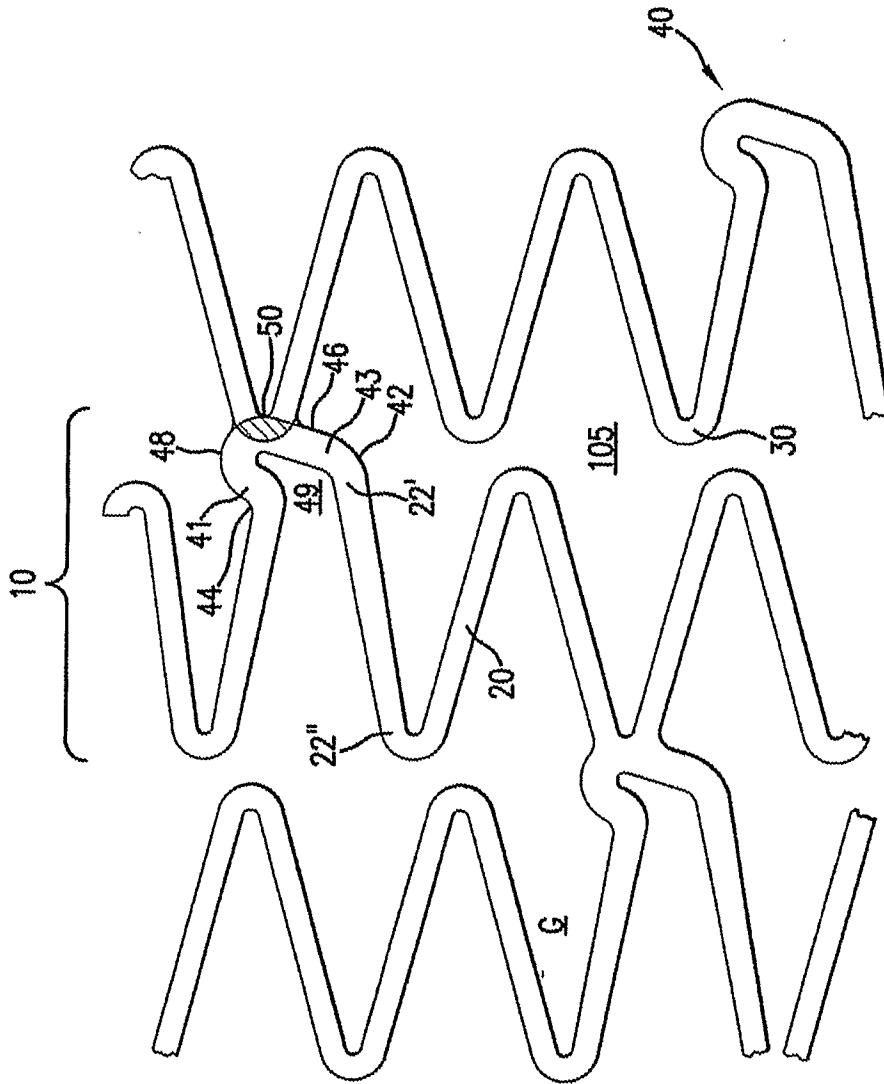

FIG.20

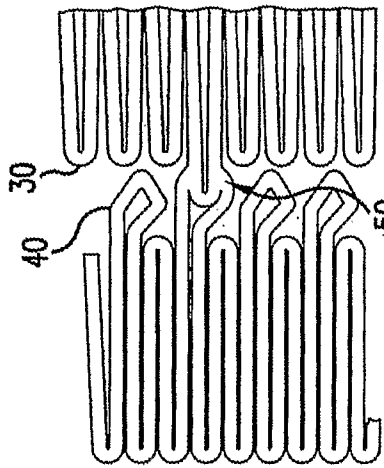

FIG. 21C

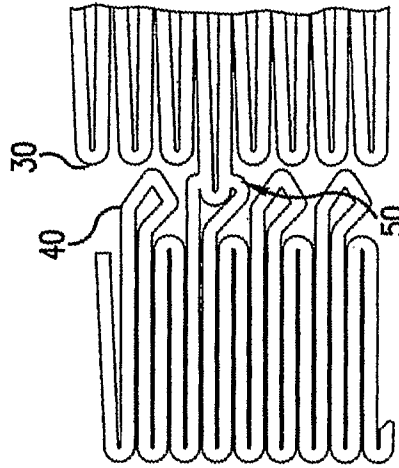

FIG. 21D

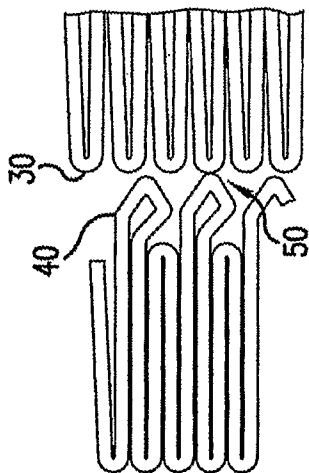

FIG. 21A

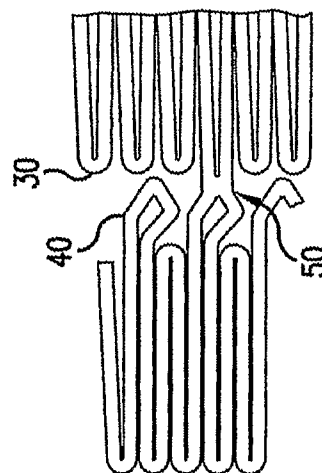

FIG. 21B

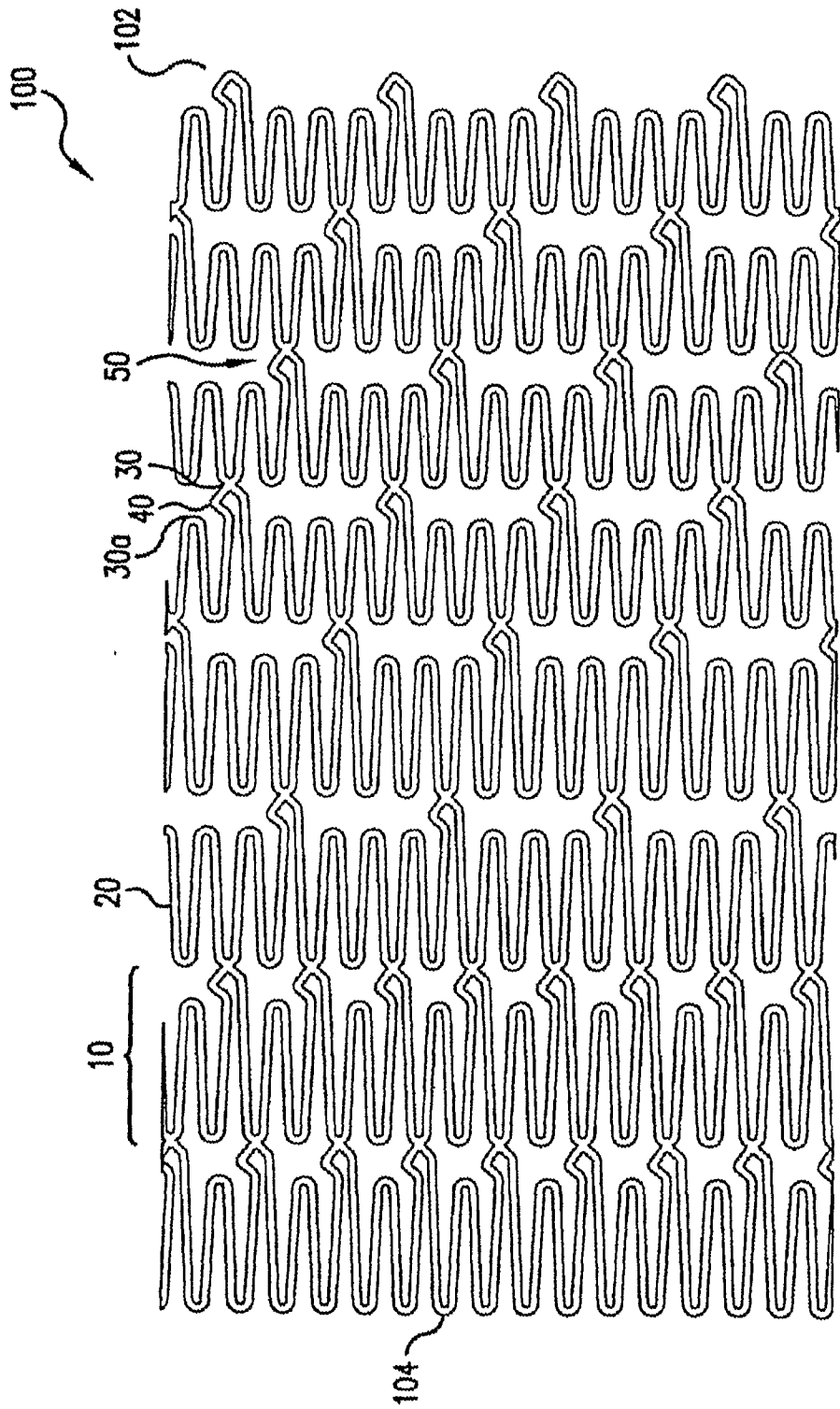

FIG. 22

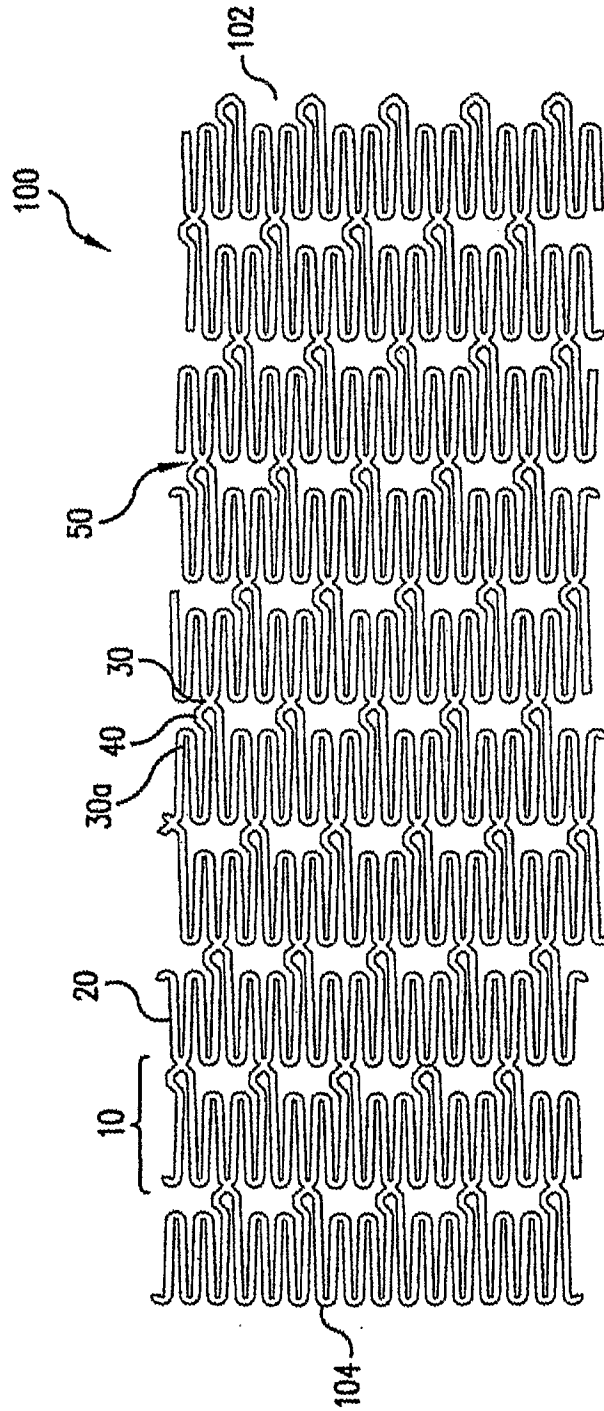

FIG. 23A

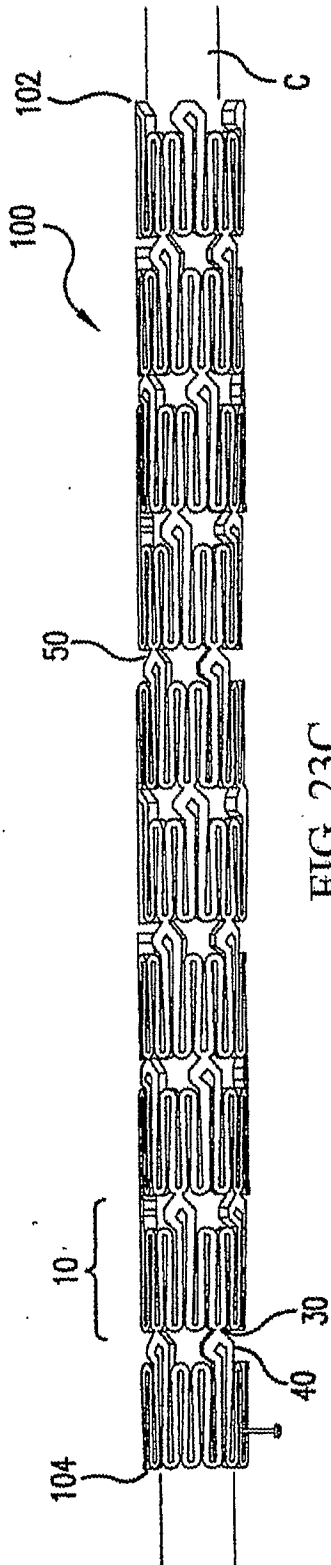

FIG. 23C

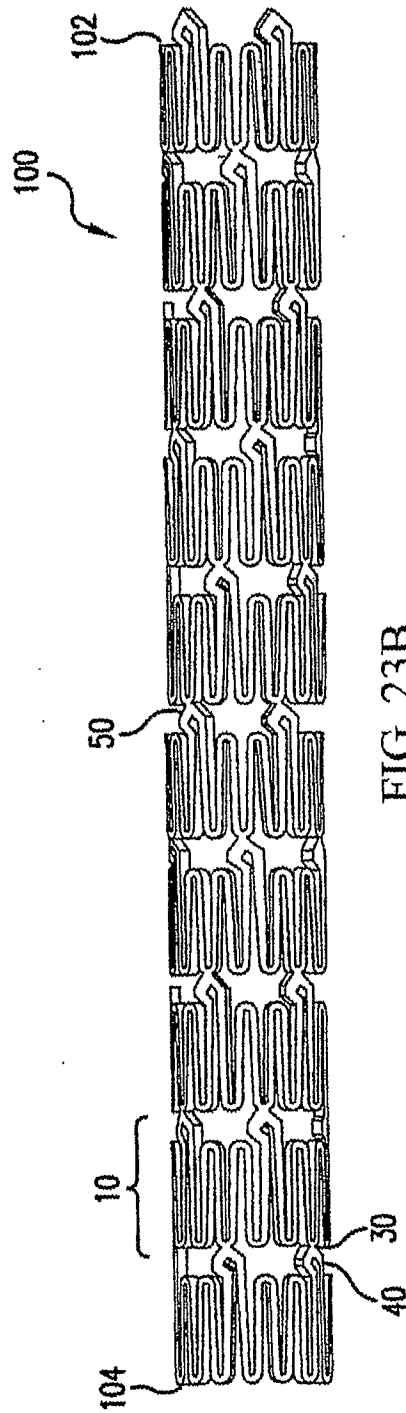

FIG. 23B

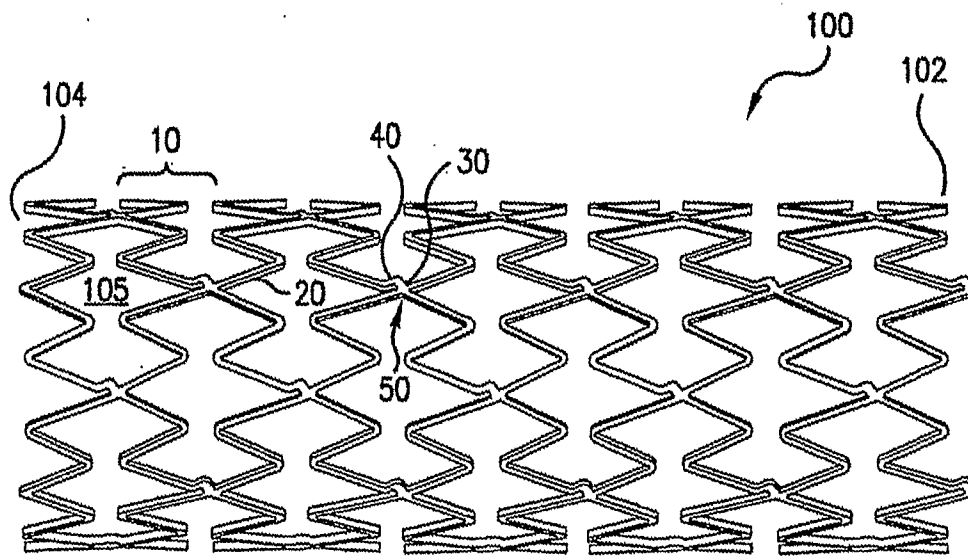

FIG. 23D

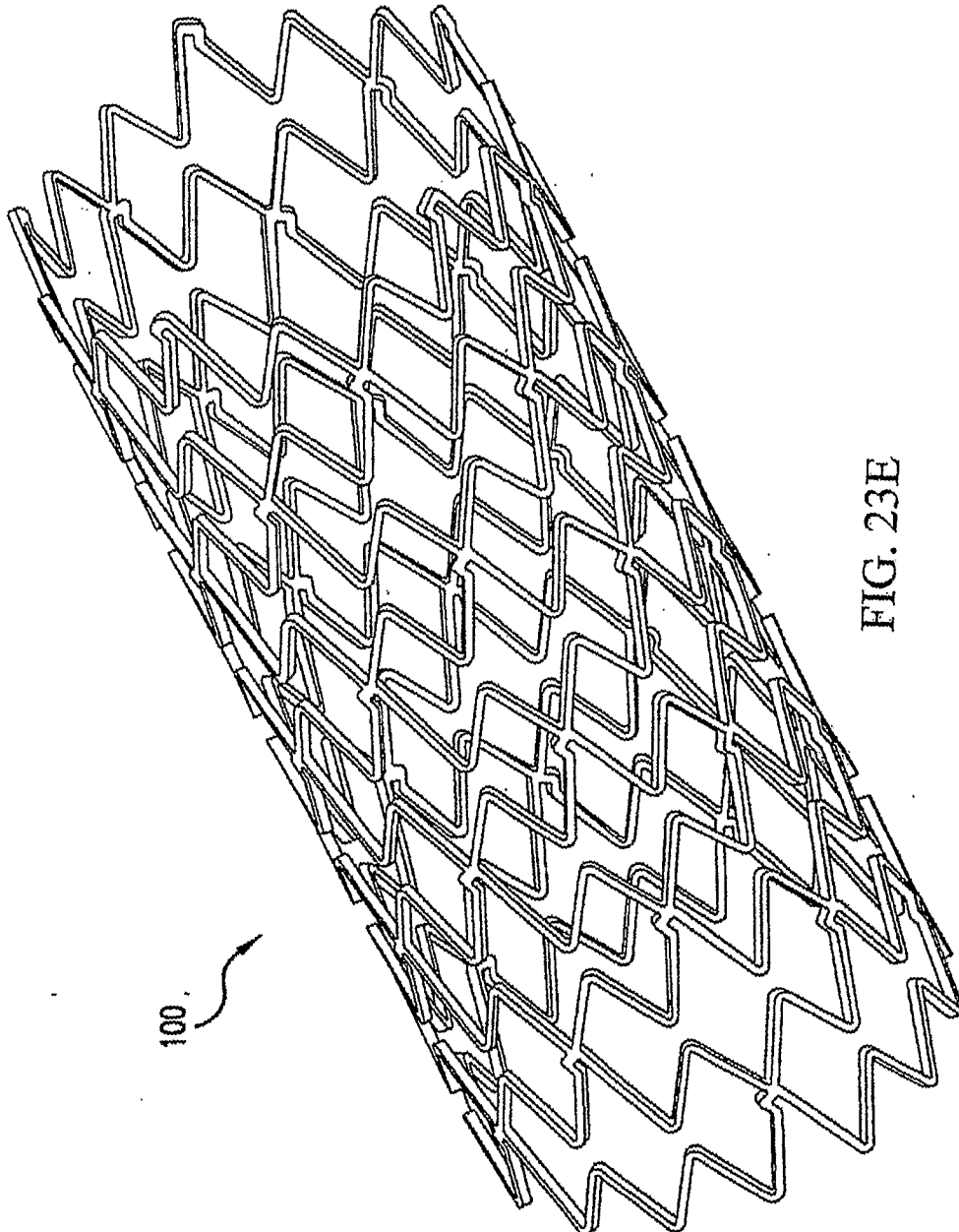

FIG. 23E

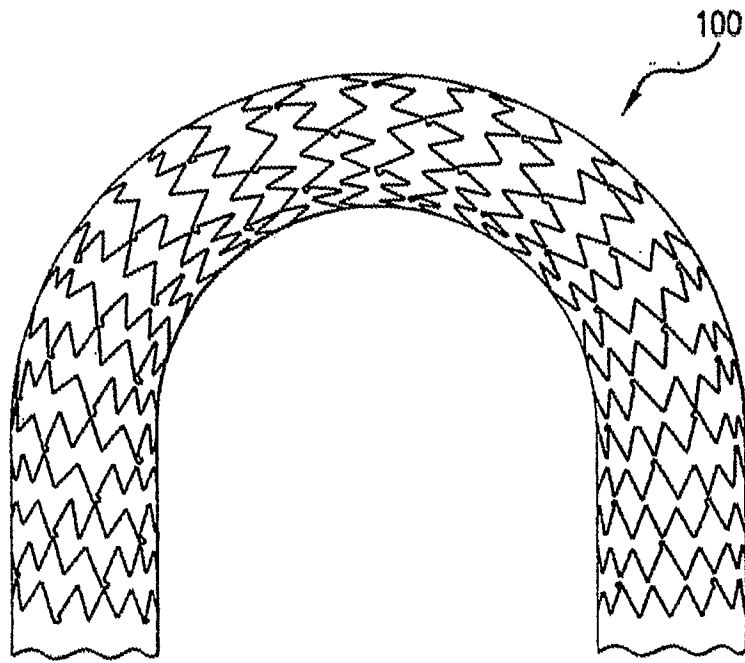

FIG. 23F

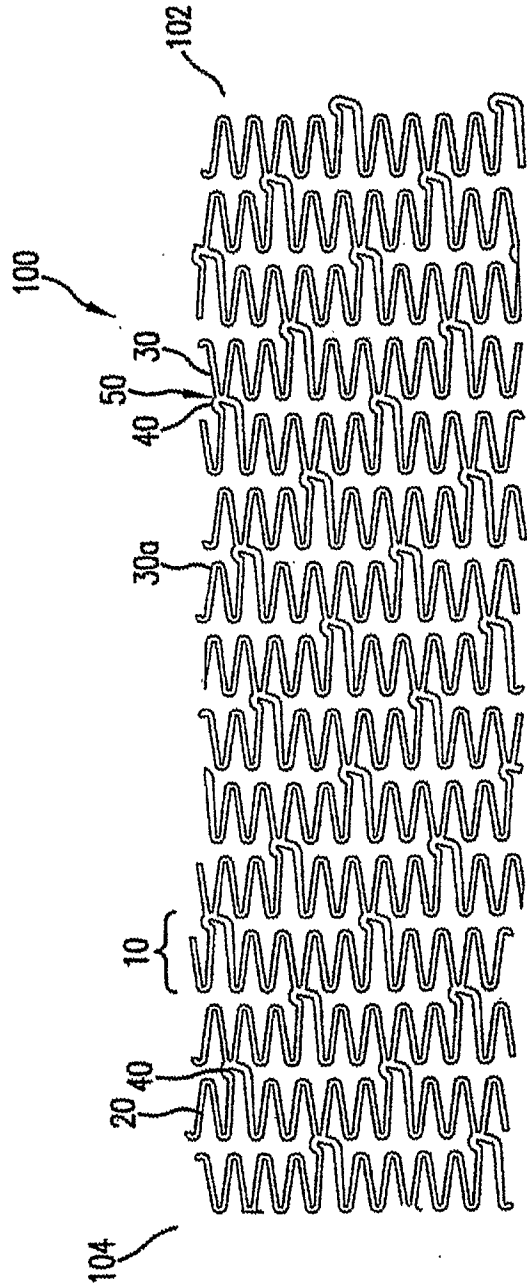

FIG. 24A

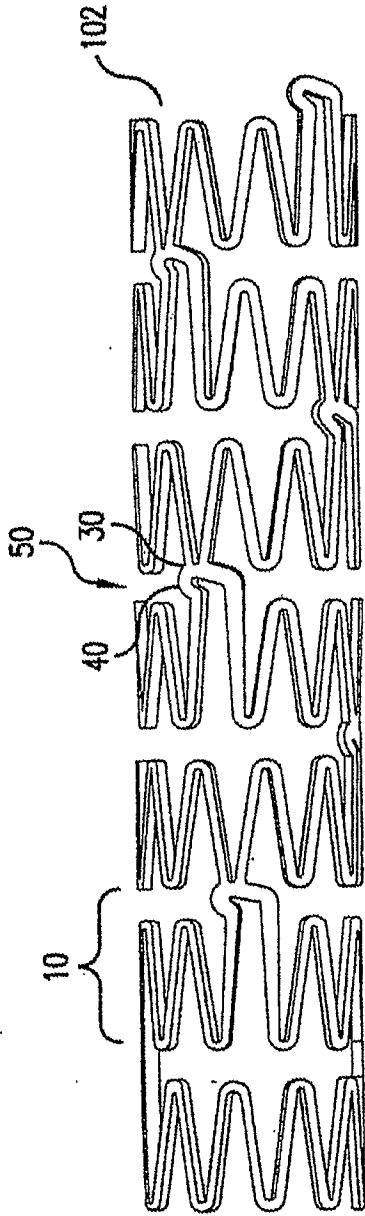

FIG. 24B

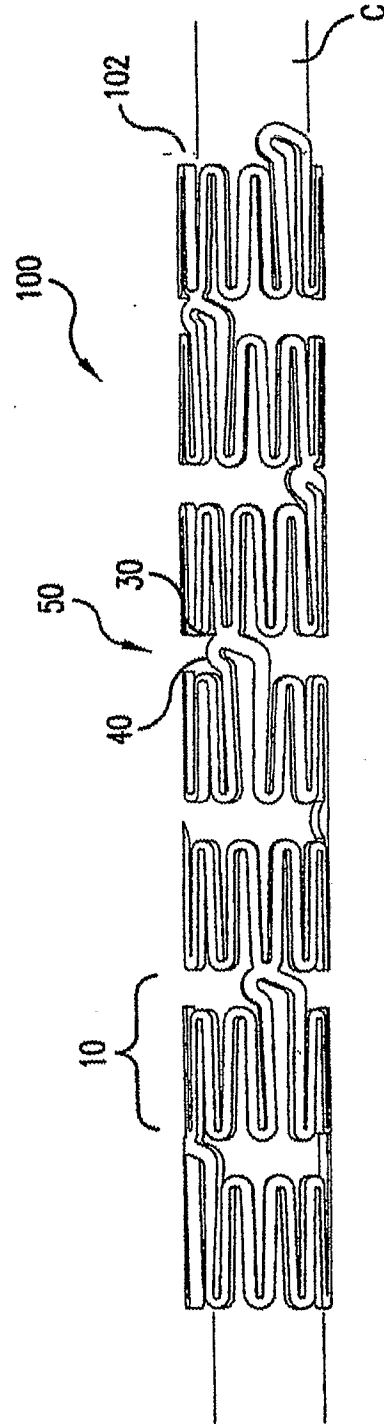

FIG. 24C

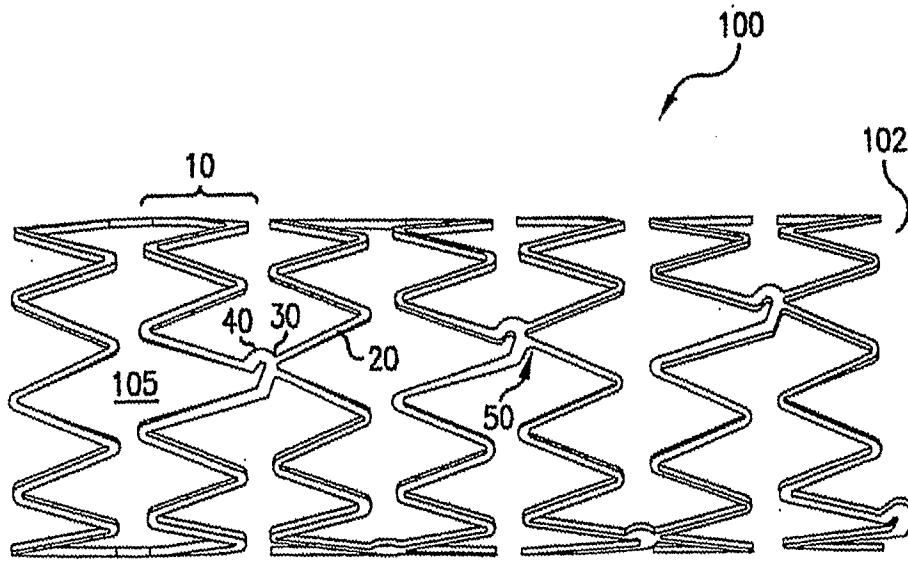

FIG. 24D

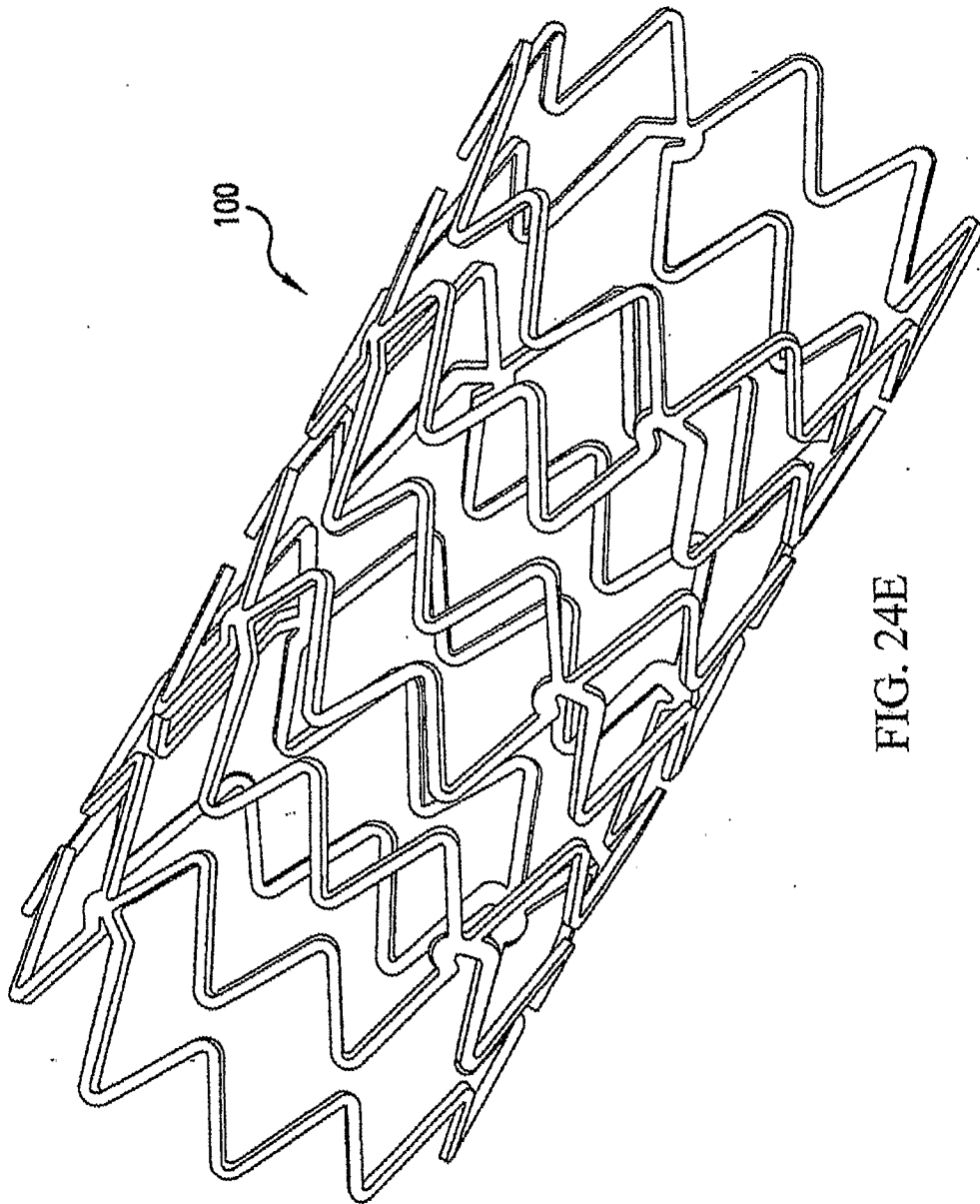

FIG. 24E

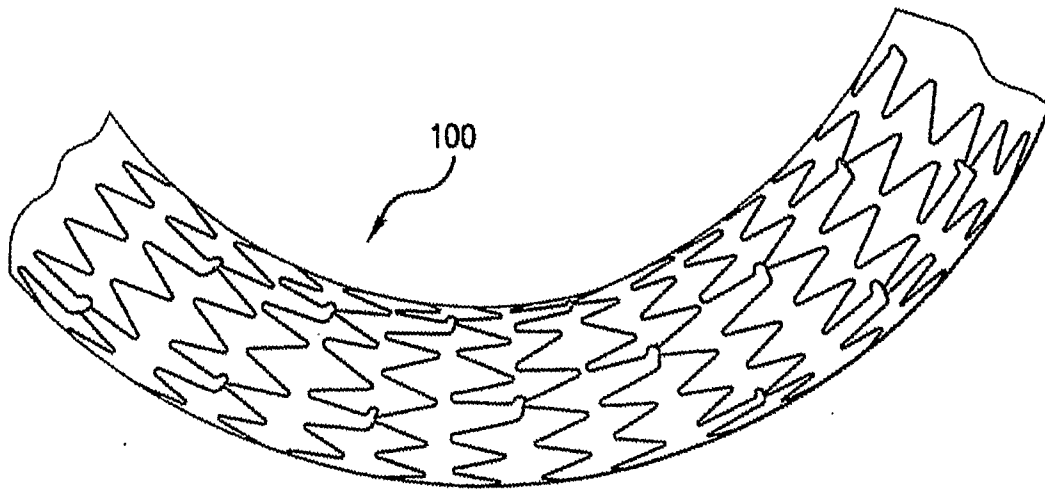

FIG. 24F

INTERNATIONAL SEARCH REPORT

International application No
PCT/US2006/025926

A. CLASSIFICATION OF SUBJECT MATTER
INV. A61F2/06 B21J15/02

According to International Patent Classification (IPC) or to both national classification and IPC

B. FIELDS SEARCHED

Minimum documentation searched (classification system followed by classification symbols)
A61F B21J F16B

Documentation searched other than minimum documentation to the extent that such documents are included in the fields searched

Electronic data base consulted during the international search (name of data base and, where practical, search terms used).

EPO-Internal

C. DOCUMENTS CONSIDERED TO BE RELEVANT

Category*	Citation of document, with indication, where appropriate, of the relevant passages	Relevant to claim No.
X	WO 97/33534 A (MEDTRONIC, INC; GLOBERMAN, OREN; BEYAR, MORDECHAY; BEYAR, RAFAEL; DOR,) 18 September 1997 (1997-09-18)	1-3,7-9
Y	page 5, line 19 - line 24 figure 7	4-6
Y	US 3 561 102 A (JOSEPH A. DIEMER) 9 February 1971 (1971-02-09) column 5, line 3 - line 6 figure 2	4-6
Y	WO 03/047651 A (XTENT, INC; CHEW, SUNMI; ANDREAS, BERNARD; GIFFORD, HANSON, S., III; F) 12 June 2003 (2003-06-12) paragraph [0063] figure 7	10-19
	----- -/--	

Further documents are listed in the continuation of Box C.

See patent family annex.

* Special categories of cited documents :

- "A" document defining the general state of the art which is not considered to be of particular relevance
- "E" earlier document but published on or after the international filing date
- "L" document which may throw doubts on priority claim(s) or which is cited to establish the publication date of another citation or other special reason (as specified)
- "O" document referring to an oral disclosure, use, exhibition or other means
- "P" document published prior to the international filing date but later than the priority date claimed

- "T" later document published after the international filing date or priority date and not in conflict with the application but cited to understand the principle or theory underlying the invention
- "X" document of particular relevance; the claimed invention cannot be considered novel or cannot be considered to involve an inventive step when the document is taken alone
- "Y" document of particular relevance; the claimed invention cannot be considered to involve an inventive step when the document is combined with one or more other such documents, such combination being obvious to a person skilled in the art.
- "&" document member of the same patent family

Date of the actual completion of the international search

27 November 2006

Date of mailing of the international search report

01/12/2006

Name and mailing address of the ISA/
European Patent Office, P.B. 5818 Patentlaan 2
NL - 2280 HV Rijswijk
Tel. (+31-70) 340-2040, Tx. 31 651 epo nl,
Fax: (+31-70) 340-3016

Authorized officer

Amaro, Henrique

INTERNATIONAL SEARCH REPORT

International application No

PCT/US2006/025926

C(Continuation). DOCUMENTS CONSIDERED TO BE RELEVANT		
Category*	Citation of document, with indication, where appropriate, of the relevant passages	Relevant to claim No.
Y	US 6 258 117 B1 (CAMRUD ALLEN R ET AL) 10 July 2001 (2001-07-10) column 8, line 54 - line 57 figure 4c	10, 13-15,18
Y	EP 1 356 789 A (CORDIS CORPORATION) 29 October 2003 (2003-10-29) paragraph [0040] paragraph [0046] figures 7,9	11,12
Y	WO 03/094798 A (ABBOTT LABORATORIES; LOWE, DAVID, L; ELI, ERIK; PAPPAS, JEFF, M; HUANG) 20 November 2003 (2003-11-20)	16,17,19
A	page 10, line 4 - line 22 figures 1,2a	19
A	DE 102 23 399 A1 (HAINDL, HANS) 11 December 2003 (2003-12-11) paragraph [0023] figure 1	10
A	US 2004/073291 A1 (BROWN BRIAN ET AL) 15 April 2004 (2004-04-15) paragraph [0033] figure 3	12
A	WO 2004/064911 A (SAMSUNG LIFE PUBLIC WELFARE FOUNDATION; PARK, JEONG-EUY) 5 August 2004 (2004-08-05) page 8, line 13 - line 19 figure 5	19

INTERNATIONAL SEARCH REPORT

International application No.
PCT/US2006/025926

Box II Observations where certain claims were found unsearchable (Continuation of item 2 of first sheet)

This International Search Report has not been established in respect of certain claims under Article 17(2)(a) for the following reasons:

1. Claims Nos.:
because they relate to subject matter not required to be searched by this Authority, namely:

2. Claims Nos.:
because they relate to parts of the International Application that do not comply with the prescribed requirements to such an extent that no meaningful International Search can be carried out, specifically:

3. Claims Nos.:
because they are dependent claims and are not drafted in accordance with the second and third sentences of Rule 6.4(a).

Box III Observations where unity of invention is lacking (Continuation of item 3 of first sheet)

This International Searching Authority found multiple inventions in this international application, as follows:

see additional sheet

1. As all required additional search fees were timely paid by the applicant, this International Search Report covers all searchable claims.
2. As all searchable claims could be searched without effort justifying an additional fee, this Authority did not invite payment of any additional fee.
3. As only some of the required additional search fees were timely paid by the applicant, this International Search Report covers only those claims for which fees were paid, specifically claims Nos.:
4. No required additional search fees were timely paid by the applicant. Consequently, this International Search Report is restricted to the invention first mentioned in the claims; it is covered by claims Nos.:

Remark on Protest

- The additional search fees were accompanied by the applicant's protest.
- No protest accompanied the payment of additional search fees.

FURTHER INFORMATION CONTINUED FROM PCT/ISA/ 210

This International Searching Authority found multiple (groups of) inventions in this international application, as follows:

1. claims: 1-9

A method of inserting a radiopaque marker in an endoprosthesis

2. claims: 10-20

An endoprosthesis for delivery in a body lumen

INTERNATIONAL SEARCH REPORT

Information on patent family members

International application No

PCT/US2006/025926

Patent document cited in search report	Publication date	Patent family member(s)	Publication date
WO 9733534	A	18-09-1997	NONE
US 3561102	A	09-02-1971	NONE
WO 03047651	A	12-06-2003	NONE
US 6258117	B1	10-07-2001	NONE
EP 1356789	A	29-10-2003	NONE
WO 03094798	A	20-11-2003	NONE
DE 10223399	A1	11-12-2003	NONE
US 2004073291	A1	15-04-2004	NONE
WO 2004064911	A	05-08-2004	NONE