



(11) **EP 1 895 039 A2**

(12) **EUROPEAN PATENT APPLICATION**

(43) Date of publication:  
**05.03.2008 Bulletin 2008/10**

(51) Int Cl.:  
**D06F 25/00 (2006.01) D06F 29/00 (2006.01)**  
**D06F 58/02 (2006.01) D06F 58/10 (2006.01)**

(21) Application number: **07016943.8**

(22) Date of filing: **29.08.2007**

(84) Designated Contracting States:  
**AT BE BG CH CY CZ DE DK EE ES FI FR GB GR HU IE IS IT LI LT LU LV MC MT NL PL PT RO SE SI SK TR**  
Designated Extension States:  
**AL BA HR MK YU**

(72) Inventor: **Lim, Min Kyu**  
**Changwon-si**  
**Gyeongsangnam-do**  
**641-711 (KR)**

(30) Priority: **31.08.2006 KR 20060083384**

(74) Representative: **TER MEER - STEINMEISTER & PARTNER GbR**  
**Mauerkircherstrasse 45**  
**81679 München (DE)**

(71) Applicant: **LG Electronics Inc.**  
**Seoul, 150-721 (KR)**

(54) **Auxiliary dryer and complex laundry machine including the same**

(57) An auxiliary dryer (120) and a complex laundry machine (100) are disclosed, by which a laundry machine (110) having a relatively large size can be conveniently operated to save energy in a manner of handling a small laundry (162) and the like without out driving the laundry machine (110). The present invention includes a body

(121) having a laundry accommodating part for accommodating a laundry therein, a hot air supplying means (140) provided within the body (121) to supply hot air to the laundry accommodating part, and a safety means (190) for preventing a safety accident from being caused to a user by the hot air supplying means (140).

**FIG.2**

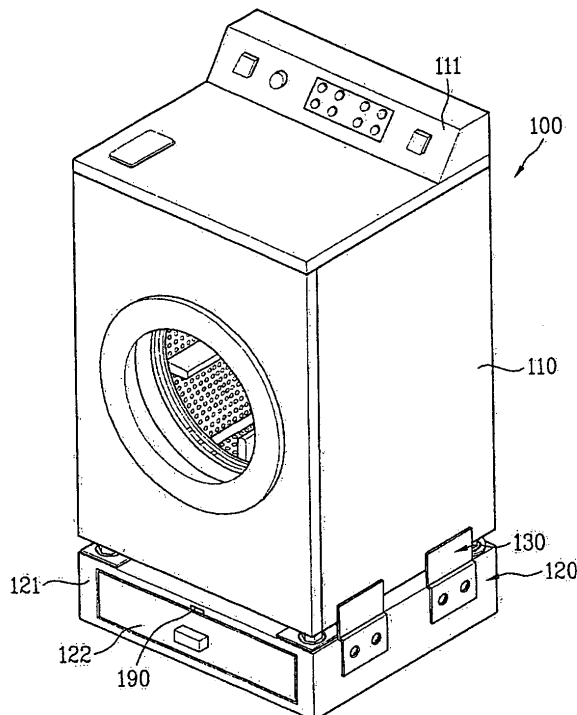

**EP 1 895 039 A2**

## Description

[0001] This application claims the benefit of the Korean Patent Application No. 10-2006-0083384, filed on August 31, 2006, which is hereby incorporated by reference as if fully set forth herein.

## BACKGROUND OF THE INVENTION

### Field of the Invention

[0002] The present invention relates to an auxiliary dryer, and more particularly, to an auxiliary dryer and a complex laundry machine including the same. Although the present invention is suitable for a wide scope of applications, it is particularly suitable for combining the auxiliary dryer with a washer to provide the complex laundry machine.

### Discussion of the Related Art

[0003] Generally, a laundry machine means a device for carrying out washing, drying or both on clothes or dresses. A single laundry machine performs either a washing function or a drying function or can perform both of the functions.

[0004] Recently, a laundry machine equipped with a steam supply device has been developed and used to perform refresh functions for creases removal, deodorization, static electricity removal, etc.

[0005] Laundry machines according to a related art are categorized into front loading type laundry machines and top loading type laundry machines according to a direction of loading/unloading a laundry. Alternatively, the laundry machines can be categorized into a vertical type laundry machine of which pulsator or a washing tub is rotated and a horizontal type laundry machine of which drum is rotated according to a washing system. One representative example for the horizontal type is a drum type washing machine or a drum type dryer.

[0006] Those laundry machines gradually tend to grow in size to meet the user's demand. In particular, laundry machines for home appliances tend to grow in exterior size.

[0007] Meanwhile, a washing machine among the related art laundry machines may not be equipped with a drying function. In case that a user needs a drying function, a dryer has to be purchased in addition or a washing machine equipped with a drying function has to be purchased. So, a consumer has to pay more costs to use both washing and drying functions.

[0008] As laundry machines having the drying function tend to grow in size gradually, a large-size dryer is inevitably driven to dry a small quantity of laundry. This is disadvantageous in aspect of energy saving.

[0009] In case of a drum type dryer, it is difficult to dry shoes, laundry and the like. Of course, a rack is provided within a drum, shoes and the like are mounted on the

rack, and a drying course is then carried out on the shoes and the like by maintaining the rack at a horizontal level regardless of revolutions of the drum. If so, it is inconvenient for a user to attach/detach the rack.

[0010] FIG. 1 is a perspective diagram of a laundry machine according to a related art.

[0011] Referring to FIG. 1, a laundry machine according to a related art consists of a body configuring an exterior of the laundry machine and a control panel provided to a topside or front side of the body 10.

[0012] And, the control panel can include a control unit for controlling operations of the laundry machine. So, a user manipulates the control panel to perform laundry processing for washing, drying and the like.

[0013] In this case, the laundry machine may include a washing machine, a dryer or a washer & dryer.

[0014] The related art laundry machine can further consist of a support 200 for supporting the body 10 over a floor. In particular, the body 10 is mounted on the support 20.

[0015] A prescribed space is normally provided within the support 20. In particular, the prescribed space is configured to have a shape of a drawer 21 that can be opened in a front direction.

[0016] However, the related art fails to assign a prescribed function for laundry process to the support 20. So, it is necessary to safely use the support 20 as an auxiliary laundry handling device.

## SUMMARY OF THE INVENTION

[0017] Accordingly, the present invention is directed to an auxiliary dryer and a complex laundry machine including the same that substantially obviate one or more problems due to limitations and disadvantages of the related art.

[0018] An object of the present invention is to provide an auxiliary dryer, by which a laundry machine having a relatively large size can be conveniently operated to save energy in a manner of handling a small laundry and the like without out driving the laundry machine.

[0019] Another object of the present invention is to provide a complex laundry machine, by which a drying function can be easily provided to a laundry machine having a washing function only.

[0020] Another object of the present invention is to provide a complex laundry machine, by which shoes or such a laundry as a hat and the like having difficulty in being dried by a related art drum type dryer can be easily dried.

[0021] Another object of the present invention is to provide an auxiliary dryer and a complex laundry machine including the same, by which an auxiliary space of a support of a related art laundry machine or the like is utilized as the auxiliary dryer.

[0022] A further object of the present invention is to provide an auxiliary dryer and a complex laundry machine including the same, by which safety can be secured in using the auxiliary dryer or the complex laundry ma-

chine.

**[0023]** Additional advantages, objects, and features of the invention will be set forth in part in the description which follows and in part will become apparent to those having ordinary skill in the art upon examination of the following or may be learned from practice of the invention. The objectives and other advantages of the invention may be realized and attained by the structure particularly pointed out in the written description and claims hereof as well as the appended drawings.

**[0024]** To achieve these objects and other advantages and in accordance with the purpose of the invention, as embodied and broadly described herein, an auxiliary dryer according to the present invention includes a body having a laundry accommodating part for accommodating a laundry therein, a hot air supplying means provided within the body to supply hot air to the laundry accommodating part, and a safety means for preventing a safety accident from being caused to a user by the hot air supplying means.

**[0025]** In this case, the auxiliary dryer can be independently installed to use.

**[0026]** Preferably, the auxiliary dryer is assembled to a laundry machine by an assembling means. Since the auxiliary dryer is a device for auxiliary laundry handling, it is preferable that devices for laundry handling are accumulated in one place to smoothly perform a series of laundry handling procedures.

**[0027]** Preferably, the auxiliary dryer is assembled to the laundry machine in aspect of space utilization.

**[0028]** Of course, the laundry machine is a main device such as a washer for performing washing only, a dryer for performing drying only, and a washer & dryer for performing both. Moreover, the laundry machine includes a dewatering device for performing dewatering only.

**[0029]** Preferably, the auxiliary dryer includes a support for supporting the laundry machine against a floor.

**[0030]** In this case, the laundry accommodating part communicates with an external environment via a door provided to the body of the auxiliary dryer. And, the door can include a front part of a drawer. So, the laundry accommodating part can have a configuration of a drawer that can be opened in a front direction from the front side of the auxiliary dryer body.

**[0031]** The safety means can be configured in various shapes to prevent a safety accident from being caused to a user.

**[0032]** Since air is supplied into the laundry accommodating part, if the door is open or if the auxiliary dryer body is filled with water to a predetermined level, it is preferable that the auxiliary dryer is not operated. If the auxiliary dryer is operated, a drying effect is degraded and a safety accident may take place. Moreover, if water is heated to overflow, a user may get burned.

**[0033]** In another aspect of the present invention, a complex laundry machine includes a laundry machine for performing washing or drying on a laundry accommodated herein and an auxiliary dryer configured smaller

than a body of the laundry machine in volume and height, the auxiliary dryer including a body having a laundry accommodating part for accommodating a laundry therein, the body assembled to the laundry machine, a door provided to the body to enable the laundry accommodating part to selectively communicate with an external environment, a hot air supplying means provided for supplying hot air to the laundry accommodating part, and a safety means for preventing a safety accident from being caused to a user by the hot air supplying means.

**[0034]** Therefore, according to the present invention, a user is able to wash a laundry or dry a considerable amount of laundries using the laundry machine. And, a small amount of laundries can be dried using the auxiliary dryer. Hence, the user is facilitated to operate the laundry machine or the auxiliary dryer and energy can be saved.

**[0035]** Moreover, shoes, dresses, hats and the like having difficulty in being dried by a related art drum type dryer can be easily dried.

**[0036]** Besides, the present invention enables the auxiliary dryer to be driven more safely through a safety device. In this case, the safety device is able to directly stop driving the hot air supplier of the auxiliary dryer, the driving unit of the steam generator, and the like. And, the safety device can stop driving the driving unit by sending a signal to the control unit.

**[0037]** It is to be understood that both the foregoing general description and the following detailed description of the present invention are exemplary and explanatory and are intended to provide further explanation of the invention as claimed.

#### **BRIEF DESCRIPTION OF THE DRAWINGS**

**[0038]** The accompanying drawings, which are included to provide a further understanding of the invention and are incorporated in and constitute a part of this application, illustrate embodiment(s) of the invention and together with the description serve to explain the principle of the invention. In the drawings:

**[0039]** FIG. 1 is a perspective diagram of a laundry machine according to a related art;

**[0040]** FIG. 2 is a perspective diagram of a complex laundry machine including an auxiliary dryer according to the present invention;

**[0041]** FIG. 3 is an exploded perspective diagram of an auxiliary dryer according to the present invention;

**[0042]** FIG. 4 is a schematic cross-sectional diagram of a complex laundry machine including an auxiliary dryer according to one embodiment of the present invention; and

**[0043]** FIG. 5 is a cross-sectional diagram of a complex laundry machine including an auxiliary dryer according to another embodiment of the present invention.

#### **DETAILED DESCRIPTION OF THE INVENTION**

**[0044]** Reference will now be made in detail to the pre-

ferred embodiments of the present invention, examples of which are illustrated in the accompanying drawings. Wherever possible, the same reference numbers will be used throughout the drawings to refer to the same or like parts.

**[0045]** First of all, since a laundry machine according to one embodiment of the present invention may include a general washing machine, a general dryer or a general washer & dryer, its details will be omitted in the following description.

**[0046]** An auxiliary dryer according to one embodiment of the present invention is explained with reference to FIG. 2 and FIG. 3 as follows.

**[0047]** FIG. 2 is a perspective diagram of a complex laundry machine including an auxiliary dryer according to the present invention, and FIG. 3 is an exploded perspective diagram of an auxiliary dryer according to the present invention.

**[0048]** First of all, the present invention can be configured with the same exterior of the laundry machine, which is provided with the support 20, shown in FIG. 1. Yet, the present invention differs from the related art in that a support, as shown in FIG. 2 or FIG. 3, performs an auxiliary drying function as well as a simple support function. And, the present invention also differs from the related art in that an assembling means 130 for assembling the auxiliary dryer to the laundry machine stably is provided to the auxiliary dryer.

**[0049]** Referring to FIG. 2, an auxiliary dryer body 121 is provided to one side of a laundry machine body 110. In particular, the auxiliary dryer body 121, as shown in FIG. 2, can be provided under the laundry machine body 110. Alternatively, the auxiliary dryer body 121 can be provided over the laundry machine body 110. In this case, a control unit of the laundry machine, and more particularly, a control panel 111 is preferably provided to a front side of the laundry machine body 110.

**[0050]** Alternatively, the auxiliary dryer 120 can be provided to a lateral side of the laundry machine. Yet, in aspect of space utilization or design, the auxiliary dryer is preferably provided over or under the laundry machine body 110.

**[0051]** The auxiliary dryer 120 according to the present invention, as shown in FIG. 2 and FIG. 3, includes the body 121 having a space for accommodating a laundry therein and the assembling means 130 provided to an upper part of the body 121. The assembling means 130 assembles the body 121 and the laundry machine body 110 together. In this case, the auxiliary dryer 120 supports the laundry machine body 110 over a floor.

**[0052]** The auxiliary dryer 120 can further include leg supporters 125 provided to a topside of the auxiliary dryer 120 to support lateral sides of lower legs 116 and 117 of the laundry machine.

**[0053]** Each of the leg supporters 125 includes a panel provided with a first holding hole 126 enabling a washer leg 116 to be held and a second holding hole 127 enabling a dryer leg 117 to be held. And, each of the leg supporters

125 is fixed to the topside of the auxiliary dryer body 121 by screws or the like. In this case, a washer or a dryer configures an example for a laundry machine. In particular, the washer is larger than the dryer for example.

**[0054]** The leg supporters 125 are fixed to corners of the topside of the auxiliary dryer body 121, respectively. The first and second holding holes 126 and 127 provided to each of the two leg supporters 125 at the front corners of the auxiliary dryer body 121 are connected to each other, while the first and second holding holes 126 and 127 provided to each of the two leg supporters 125 at the rear corners of the auxiliary dryer body 121 are separated from to each other. This facilitates the washer legs 116 to be held.

**[0055]** The first holding hole 126 is formed at a position outer than that of the second holding hole 126 with reference to a diagonal line of a bottom of the laundry machine body 110. This is because a body of the washer is normally configured larger than that of the dryer.

**[0056]** The assembling means 130 includes an assembling member 138 provided to a lower lateral side of the washer or dryer and a lateral side of the auxiliary dryer body 121 and a fixing member 135 fixing the assembling member 138 to the lateral side of the washer or dryer and the lateral side of the auxiliary dryer body 121.

**[0057]** The assembling member 138, as shown in FIG. 3, can include at least two assembling members 138 mutually fixing both lateral sides on a boundary between the hexahedral auxiliary dryer body 121 and the hexahedral laundry machine body 110

**[0058]** In addition to the above configuration, the assembling member can further include a third assembling member (not shown in the drawings) mutually fixing back-sides of the auxiliary dryer body 121 and the laundry machine body 110.

**[0059]** In this case, the assembling means 130 can be configured to cope with a level variation of the washer leg 116 or the dryer leg 117.

**[0060]** The fixing member 135 includes a first fixing member 136 fixing an upper part of the assembling member to a lower lateral side of the washer or dryer and a second fixing member 137 fixing a lower part of the assembling member to an upper lateral side of the support.

**[0061]** In this case, at least one of the first and second fixing members 136 and 137 includes a member having both sides coated with an adhesive substance, i.e., a double-stick foam tape.

**[0062]** Alternatively, at least one of the first and second fixing members 136 and 137 can include a locking means such as a screw.

**[0063]** If the fixing member includes the screw, locking holes are provided to the assembling member to be spaced apart from each other.

**[0064]** Alternatively, the means for assembling the laundry machine body 110 and the auxiliary dryer body 121 together can be variously modified.

**[0065]** Preferably, a volume of the auxiliary dryer body 121 is smaller than that of the laundry machine body 110

to which the auxiliary dryer is assembled.

**[0066]** Preferably, a height of the auxiliary dryer body 121 is smaller than that of the laundry machine. This is because the object of the auxiliary dryer of the present invention is to perform an auxiliary function of the laundry machine.

**[0067]** In aspect of the safety or exterior design of the complex laundry machine 100, in case that the auxiliary dryer performs a support function of the laundry machine, at least one of right-to-left width or front-to-rear width of the auxiliary dryer body 121 is preferably configured equal to or greater than at least one of right-to-left width or front-to-rear width of the laundry machine body 110. In case that the auxiliary dryer is assembled to an upper part of the laundry machine, at least one of right-to-left width or front-to-rear width of the auxiliary dryer body 121 is preferably configured equal to or smaller than at least one of right-to-left width or front-to-rear width of the laundry machine body 110.

**[0068]** Detailed configuration of an auxiliary dryer according to the present invention is explained with reference to FIG. 4 as follows.

**[0069]** FIG. 4 is a schematic cross-sectional diagram of a complex laundry machine including an auxiliary dryer according to one embodiment of the present invention.

**[0070]** Referring to FIG. 4, an auxiliary dryer 120 according to the present invention is assembled to a laundry machine body 110 to construct a complex laundry machine 100. In this case, a laundry is accommodated in the body 110 configuring an exterior to be washed or dried. In particular, the laundry machine can be a washer, a dryer or a washer & dryer.

**[0071]** The complex laundry machine 100 includes an assembling means 130 (not shown in the drawing) for assembling the auxiliary dryer body 121 to one side of the laundry machine body 110.

**[0072]** A laundry accommodating part is provided within the auxiliary dryer 120 to perform an auxiliary function for laundry handling. The laundry accommodating part can be configured to have a drawer shape 122 that can be opened in a front direction from a front side of the body 121.

**[0073]** And, a hot air supplying device 140 is provided within the auxiliary dryer body 121 to force air to be supplied into the space.

**[0074]** Preferably, the body 121 of the auxiliary dryer 120 is configured smaller than the laundry machine body 110 assembled to the auxiliary dryer 120 in volume and height.

**[0075]** The auxiliary dryer 120 includes a steam supplying device 150 provided within the body 121 to supply steam to the space for accommodating the laundry.

**[0076]** And, the steam supplying device 150 includes an injection hole (not shown in the drawing) to inject the steam into the internal space via an upper or rear portion of the body.

**[0077]** Each of the hot air supplying device 140 and the steam supplying device 150 is controlled to be driven

by a control unit 123. Preferably, the control unit 123 is provided to the front side of the body 121. More preferably, the control unit 123 includes a control panel for user's manipulations.

**[0078]** Independent from the control unit 111 of the laundry machine, the control unit 123 is capable of controlling the drive of the auxiliary dryer 120.

**[0079]** Of course, the drive of the auxiliary dryer 120 can be controlled by the control unit 111 of the laundry machine. In this case, the control unit 123 of the auxiliary dryer 120 can be omitted.

**[0080]** The hot air supplying device 140 includes a blower fan 141 for blowing air and a heater 142 for heating air. In particular, if the blower fan 141 is driven, external air is introduced into the drawer 123 and then discharged externally. The external air is heated by the heater 142 and then introduced into the drawer 123.

**[0081]** The heater 142 can include one of various type heaters such as an electric heater, a gas type heater, and the like. Preferably, the electric heater is used as the heater 142 for an installation space within the auxiliary dryer 120.

**[0082]** The hot air supplying device 140 enables the auxiliary dryer 120 according to the present invention to perform a drying function.

**[0083]** Preferably, the heater 142 is capable of adjusting a capacity to vary a temperature of the air heated by the heater. This is because specific dresses are vulnerable to heat. In particular, rubber substance of shoes and the like is vulnerable to heat.

**[0084]** The steam supplying device 150 supplies steam into the drawer. The steam comes into contact with the laundry accommodated in the drawer to perform sterilization, creases removal, and the like. Hence, the auxiliary dryer 120 according to the present invention can perform a refresh function due to the steam supplying device 150. Of course, both of the refresh function and the drying function can be simultaneously performed.

**[0085]** Preferably, an intake port 171 for introducing air is provided to an upper part of a rear wall of the auxiliary dryer body 121.

**[0086]** Preferably, a discharging hole 172 for discharging air is provided to a lower part of the rear wall of the body 121.

**[0087]** An upper part of a rear wall of the drawer 122 is configured to communicate with the intake port 171 and a lower part of the rear wall of the drawer 122 is configured to communicate with the discharging hole 172. Hence, external air is introduced into the drawer via the upper part of the rear wall of the body 121 and the upper part of the drawer. The air is then discharged via the lower part of the drawer and the lower part of the rear wall of the auxiliary dryer body 121.

**[0088]** In this case, the blower fan 141 for forcing the air to flow and the heater 142 for heating the air can be provided between the rear wall of the drawer and the rear wall of the body.

**[0089]** Alternatively, the hot air supplying device 140

including the blower fan 141 and the heater 142 can be provided to any place on passages for introducing and discharging air.

**[0090]** FIG. 4 shows a configuration for introducing air via an upper part of a drawer and discharging the air via a lower part of the drawer. Alternatively, another configuration for introducing air via a lower part of a drawer and discharging the air via an upper part of the drawer is available.

**[0091]** A rack 160, as shown in FIG. 4, can be provided within the drawer 123 to partition an inner space of the drawer into an upper space and a lower space configured to communicate with each other. And, a laundry 162 is loaded on the rack 160. The object of the rack 160 is to discharge the air supplied to the laundry 162 smoothly.

**[0092]** Preferably, a multitude of perforated holes 160a are provided to the rack 160. So, air can be introduced into the lower space of the drawer from the upper space of the drawer via the perforated holes 160a.

**[0093]** Optionally, the rack 160 can be installed to incline. In this case, it is preferable that the rack 160 is installed to incline downward toward a portion from which the air is introduced. So, air can be evenly supplied to the laundry loaded on the rack 160.

**[0094]** Preferably, an air guide 161 is provided to the upper part of the drawer. The air guide 161 performs a function of supplying air to a front of the drawer smoothly and a partitioning function for a passage of introduced air and a passage of discharged air. So, collision between the introduced air and the discharged air is minimized to raise efficiency in drying or the like.

**[0095]** The auxiliary dryer 120 according to the present invention can include a tank (not shown in the drawing) provided to a lower part of the auxiliary dryer 120 to store water. Alternatively, the tank can be replaced by a separate drain pump (not shown in the drawing) of the related art. If the drain pump, a drain hose and the like are installed, cost is raised. And, installation of the drain pump and the like is not easy. So, the tank, which can be easily emptied, is preferred to reduce cost.

**[0096]** The tank may include the laundry accommodating part 122 itself or a space between a lower part of the laundry accommodating part and a lower part of the auxiliary dryer body.

**[0097]** FIG. 4 just shows a configuration in a lower part of the laundry accommodating part 122 to store water therein.

**[0098]** In storing the water generated from the laundry in the tank or the laundry accommodating part, if the water reaches a predetermined level, it is preferable that the tank or the laundry accommodating part is emptied for safety. This is to secure safety as well as enhance the drying or refreshing effect.

**[0099]** For instance, the inside of the auxiliary dryer is frequently maintained at a high temperature. So, overflowing water is heated and leaks externally to bring about a safety accident. Moreover, the overflowing water may cause an accident such as an electric leakage.

**[0100]** For safer operations of the auxiliary dryer, the present invention includes a water level detecting device 191 for detecting a water level within the auxiliary dryer. So, the water level detecting device is included as a safety device.

**[0101]** If the water level detecting device 191 detects that a water level within the auxiliary dryer, e.g., a water level of the tank is equal to or greater than a predetermined water level, the hot air supplying device 140 and the steam generating device 150 stop being driven. So, it is able to prevent a safety accident from being caused by the overflowing water or an excessive pool of water in advance.

**[0102]** The water level detecting device 191 can be implemented in one of various forms. For instance, the water level detecting device 191 can include one of a float switch, a pressure switch, and the like. In particular, the pressure switch is connected to an air chamber built in one body of the tank to detect the water level within the tank according to a frequency variation. Since the configuration of the water level detecting device is apparent to those skilled in the art, its details will be omitted in the following description.

**[0103]** If the water level is equal to or greater than the predetermined water level, the water level detecting device is capable of stopping the driving units directly or the driving units can be stopped by the control unit.

**[0104]** The auxiliary dryer according to the present invention can include a door open detecting device 190 as a safety device. The door open detecting device 190 plays a role in preventing a safety accident from being caused to a user while the auxiliary dryer 120 is operating.

**[0105]** In particular, the front side of the drawer 122 enables an inner space of the drawer to communicate with an external environment selectively. In case of attempting to dry a laundry, a user opens the drawer, puts a laundry in the drawer, and then closes the drawer.

**[0106]** Yet, dry air or steam is supplied to an inside of the laundry accommodating part. If the dry air or steam is supplied while the drawer is open, drying or refreshing performance is considerably reduced. Moreover, hot air or steam leaks externally to cause a safety accident.

**[0107]** So, the door open detecting device 190 detects a door open and then stops driving the hot air supplying device 140 or the steam generating device 150. Namely, if the door is open, the door open detecting device 190 directly cuts off a power connected to the driving unit of the hot air supplying device 140 or the steam generating device 150 to stop driving the driving unit. Alternatively, the door open detecting device 190 delivers a door open signal to the control unit 123 for controlling the drive of the driving unit. So, the control unit 123 can stop driving the driving unit.

**[0108]** Of course, another driving means except the hot air supplying device 140 or the steam generating device 150 can be stopped by the door open detecting device 190. For instance, various sensors or a UV-ray sterilizing means for sterilizing the inside of the laundry ac-

commodating part 122 can stop being driven by the door open detecting device 190.

**[0109]** The door open detecting device 190 can be implemented with a lead switch or a tact switch normally used for a washer or the like. And, the door open detecting device 190 can be used together with a door lock system (not shown in the drawing) used for a normal washer or the like. Details of the door open detecting device 190, which are apparent to those skilled in the art, shall be omitted in the following description.

**[0110]** Various kinds of drying modes can be performed through the auxiliary dryer according to the present invention.

**[0111]** First of all, a user opens the drawer 122 and then loads the laundry 162 such as a small amount of cloth, shoes, a hat and the like on the rack 160. Preferably, the cloth is unfolded on the rack 160.

**[0112]** Subsequently, the user selects a specific operational mode according to a type of the laundry via the control unit 123 including the control panel. In this case, the operational mode includes various kinds of drying modes and a refresh mode.

**[0113]** The various kinds of drying modes can be categorized into a drying time, a drying temperature, and the like, which vary according to the type of the corresponding laundry. For instance, in order to dry a small amount of cloth of cotton, a drying time is set short and a drying temperature is set high. In order to dry shoes, a drying time is set long and a drying temperature is set low.

**[0114]** Thus, although air is forced to be supplied to a space for accommodating the laundry according to the operational mode selected by the user, the air temperature or the air supplying time vary.

**[0115]** If the operational mode is set to the refresh mode, steam at a high temperature is supplied to the laundry. So, the steam refreshes the laundry such as dresses to perform deodorization, creases removal, sterilization or the like on the laundry. Thereafter, air supply for drying can be carried out if necessary.

**[0116]** A complex laundry machine according to the present invention is explained in detail with reference to FIG. 5 as follows. The device 140 for supplying air to the laundry accommodating part 122 of the auxiliary dryer in the aforesaid complex laundry machine is provided with the auxiliary dryer body 121. Yet, in the present embodiment, the hot air supply device is provided within the laundry machine body 110.

**[0117]** FIG. 5 is a cross-sectional diagram of a complex laundry machine including an auxiliary dryer according to another embodiment of the present invention.

**[0118]** Referring to FIG. 5, a hot air supplying device for supplying air into a drum is provided with the laundry machine body 110.

**[0119]** The hot air supplying device includes a heater 90 for heating air and a blower fan 60 for blowing air. And, the hot air supply device includes a drying passage 44 guiding the air to be introduced into the drum 40 and an exhaust passage 80 guiding the air to be discharged

from the drum 40.

**[0120]** The hot air supplying device supplies air to an inner space of an auxiliary body 120, i.e., into the laundry accommodating part 122 as well as to the drum. For this, the hot air supplying device includes an auxiliary drying passage 45 and an auxiliary exhaust passage 81.

**[0121]** In this case, the auxiliary drying passage 45 can be configured to diverge from the drying passage 44. One end of the auxiliary drying passage 45 is connected to a passing hole 271 formed at one side of a base 212. The passing hole 271 communicates with an intake port 128 formed at an upper part of the auxiliary dryer body 121 to enable dry air to be introduced into the drawer.

**[0122]** And, the auxiliary exhaust passage 81 can be configured to diverge from the exhaust passage 80. One end of the auxiliary exhaust passage 81 is connected to a passing hole 272 formed at one side of the base 212. The passing hole 272 is configured to communicate with an exhaust port 129 formed at an upper part of the auxiliary body 120 to enable the air within the drawer, i.e., the air within the laundry accommodating part 122 to be exhausted.

**[0123]** Alternatively, the exhaust port 129 may not be connected to the passing hole 272. In particular, the air within the laundry accommodating part 122 can be directly discharged via the exhaust port 126. In this case, the auxiliary exhaust passage 81 can be omitted.

**[0124]** Preferably, the heater 90 is provided to the drying passage 44 ahead of the divergence of the auxiliary drying passage 45. So, a single heater is able to supply hot air to both of the drum 40 and the drawer 122. If the heater is not activated, air at room temperature will be supplied.

**[0125]** Preferably, the blower fan 60 is provided to the exhaust passage 80 behind the divergence of the auxiliary exhaust passage 81. So, a single blower fan is able to supply air to both of the drum 40 and the laundry accommodating part 122.

**[0126]** The complex laundry machine 100 according to the present invention enables air to be supplied to an inside of the laundry accommodating part 122 as well as to the drum. If necessary, the complex laundry machine 100 is able to supply air to either the drum or the drawer. Of course, the complex laundry machine 100 is able to supply air to both. For this, a means for switching the drying passage 44 or the auxiliary passage 45 selectively can be provided thereto. For instance, the means includes a damper 280.

**[0127]** The complex laundry machine 100 according to the present invention can include a steam supplying device 300 provided within the laundry machine body 110 to supply steam to the drum 40 and the inner space of the laundry accommodating part 122.

**[0128]** The steam supplying device 300 can further include a steam injecting port (not shown in the drawing) for injecting steam into the drawer as well as a steam injecting port 350 for injecting steam into the drum. So, steam can be supplied to the drum or the drawer via the

corresponding stem injecting port.

**[0129]** Alternatively, a single steam injecting port 355 can be provided to supply steam into the drum and the laundry accommodating part 122. In particular, the steam supplying device 300 can include a single steam injecting port 355 for injecting steam into the drying passage 44 behind the divergence of the auxiliary drying passage 45.

**[0130]** If steam is injected into the drying passage, the injected steam can be supplied into the drum and the laundry accommodating part via the drying passage 44 and the auxiliary drying passage 45, respectively.

**[0131]** In this case, it is preferable that the fan 60 is driven together. In this case, it is unnecessary to provide an inlet port for supplying steam separately to the auxiliary dryer body 121. This is because steam is provided via the auxiliary drying passage 45.

**[0132]** In the present invention, the steam is supplied into the drum or the drawer to refresh dresses and the like. Namely, the steam at high temperature is supplied into the drum or the laundry accommodating part to perform creases removal, static electricity prevention, deodorization, sterilization, and the like on the dresses or the like. So, after the steam has been supplied, it is preferable that heated dry air is supplied into the drum and the drawer. This is to remove the remaining dampness from the dresses in part. So, a user is able to wear the dried dresses immediately.

**[0133]** In the present invention, the heater 90, the blower fan 60, the damper 280 and the steam supplying device 300 are driven by being controlled by the control unit (not shown in the drawing). Preferably, the control unit is provided to the front side of the body 110. In this case, the control unit can include the control panel 111 for user's manipulations.

**[0134]** Under the control of the control unit, air can be forced to be supplied into the drum or the laundry accommodating part selectively and a temperature adjustment of the air and a supplying time adjustment of the air are enabled. Under the control of the control unit, steam can be selectively supplied into the drum or the laundry accommodating part.

**[0135]** In the present invention, the heater 90 is capable of adjusting a capacity to enable a temperature of the air heated by the heater to be variable. A specific laundry or dress is vulnerable to heat. Specifically, rubber substance of shoes and the like is considerably vulnerable to heat. The capacity adjustment of the heater 90 can be controlled by the control unit.

**[0136]** Like the former embodiment of the present invention, the safety device of the present embodiment can include a door open detecting device and/or a water level detecting device.

**[0137]** FIG. 5 shows a tank 192 built in one body of the laundry accommodating part 122. The tank 192 is configured to communicate with the laundry accommodating part 122 via a multitude of holes 193 provided to a bottom of the laundry accommodating part 122. So, water flows via the holes 193 and is then stored in the tank 192.

**[0138]** And, the water level detecting device 191 is provided within the tank 192. If so, even if water is reserved within the tank 102 to a prescribed extent, it is able to prevent the degradation of the drying and refreshing effects to some extent. This is because the tank 192 and the laundry accommodating part 122 do not completely communicate with each other.

**[0139]** If a water level is equal to or greater than a predetermined level, the water level detecting device works as a safety device to stop driving the driving unit. And, the water level detecting device may indicate a user to empty the tank.

**[0140]** In the present embodiment, the laundry machine is an exhaust type dryer. Yet, the present embodiment is applicable to a condensing type dryer as well. Moreover, in the present disclosure, the safety device of the auxiliary dryer includes the door open detecting device, the water level detecting device, and the control device for example. And, every safety device matching the technical idea of the present invention belongs to the scope of the appended claims and their equivalents of the present invention. Namely, the safety device including at least one of the door open detecting device and the water level detecting device can be included in the present invention.

**[0141]** Accordingly, the present invention provides the following effects or advantages.

**[0142]** First of all, the present invention provides an auxiliary dryer capable of handling a small amount of laundry and the like without driving a relatively large laundry machine, thereby facilitating a user to use a laundry machine. And, the present invention saves energy.

**[0143]** Secondly, the present invention enables a drying function to be applied to a laundry machine having a washing function only.

**[0144]** Thirdly, the present invention facilitates hats, shoes, dresses and the like, which have difficulty in being dried by the related art drum type dryer, to be dried. And, the present invention utilizes an auxiliary space such as a support of a related art laundry machine as an auxiliary dryer.

**[0145]** Therefore, the present invention maximizes space utilization with a low cost, thereby providing a convenient complex laundry machine.

**[0146]** And, the present invention secures safety in using an auxiliary dryer and a complex laundry machine including the same.

**[0147]** It will be apparent to those skilled in the art that various modifications and variations can be made in the present invention without departing from the spirit or scope of the inventions. Thus, it is intended that the present invention covers the modifications and variations of this invention provided they come within the scope of the appended claims and their equivalents.



**Claims**

1. An auxiliary dryer comprising:
- a body having a laundry accommodating part for accommodating a laundry therein; a hot air supplying means provided within the body to supply hot air to the laundry accommodating part; and a safety means for preventing a safety accident from being caused to a user by the hot air supplying means.
2. The auxiliary dryer of claim 1, the hot air supplying means comprising:
- a blower fan for blowing air; and a heater for heating air.
3. The auxiliary dryer of claim 1, further comprising a steam supplying means for injecting steam into the body.
4. The auxiliary dryer of claim 3, further comprising a door provided to the body to enable the laundry accommodating part to selectively communicate with an external environment, wherein the safety means stops at least one of the hot air supplying means and the steam supplying means if the door is open.
5. The auxiliary dryer of claim 4, the safety means comprising:
- a door open detecting means for detecting that the door is opened; and a control unit stopping an operation of at least one of the hot air supplying means and the steam supplying means if the door open detecting means detects the door is opened.
6. The auxiliary dryer of claim 5, the safety means further comprising a water level detecting means for detecting that a water level within the body is equal to or greater than a prescribed water level, wherein the control unit stops the operation of the at least one of the hot air supplying means and the steam supplying means if the water level detecting means detects that the water level within the body is equal to or greater than the prescribed water level.
7. A complex laundry machine comprising:
- a laundry machine for performing washing or drying on a laundry accommodated herein; and an auxiliary dryer configured smaller than a body of the laundry machine in volume and height, the auxiliary dryer comprising:
- a body having a laundry accommodating part for accommodating a laundry therein, the body assembled to the laundry machine; a door provided to the body to enable the laundry accommodating part to selectively communicate with an external environment; a hot air supplying means provided for supplying hot air to the laundry accommodating part; and a safety means for preventing a safety accident from being caused to a user by the hot air supplying means.
8. The complex laundry machine of claim 7, the auxiliary dryer further comprising a steam supplying means provided within the body to inject steam into the body.
9. The complex laundry machine of claim 8, the safety means comprising:
- a door open detecting means for detecting that the door is opened; and a control unit stopping an operation of at least one of the hot air supplying means and the steam supplying means if the door open detecting means detects the door is opened.
10. The complex laundry machine of claim 9, the safety means further comprising a water level detecting means for detecting that a water level within the body is equal to or greater than a prescribed water level, wherein the control unit stops the operation of the at least one of the hot air supplying means and the steam supplying means if the water level detecting means detects that the water level within the body is equal to or greater than the prescribed water level.
11. The complex laundry machine of claim 7, wherein the hot air supplying means is provided within either the laundry machine or the body of the auxiliary dryer.
12. The complex laundry machine of claim 7, wherein the auxiliary dryer comprises a support supporting the laundry machine against a floor.
13. The complex laundry machine of claim 9, further comprising a tank assembled to a lower part of the body to store water generated from the laundry accommodated in the laundry accommodating part.
14. The complex laundry machine of claim 13, wherein a multitude of holes are provided to a bottom of the laundry accommodating part to enable the water generated from the laundry accommodated in the laundry accommodating part to be drained.

15. The complex laundry machine of claim 14, the safety means further comprising a water level detecting means for detecting a water level within the tank, wherein the control unit stops the operation of the at least one of the hot air supplying means and the steam supplying means if the water level detecting means detects that the water level within the tank is equal to or greater than a prescribed water level.

5

10

15

20

25

30

35

40

45

50

55

FIG.1  
Related Art

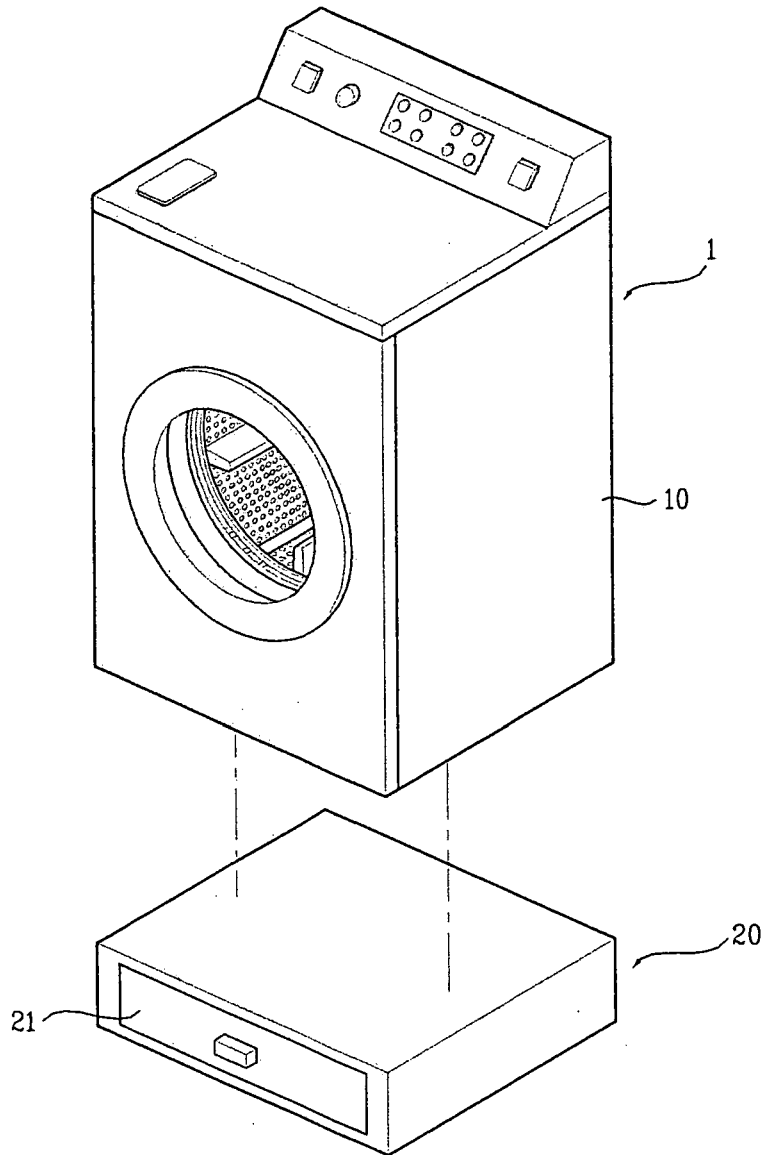

FIG.2

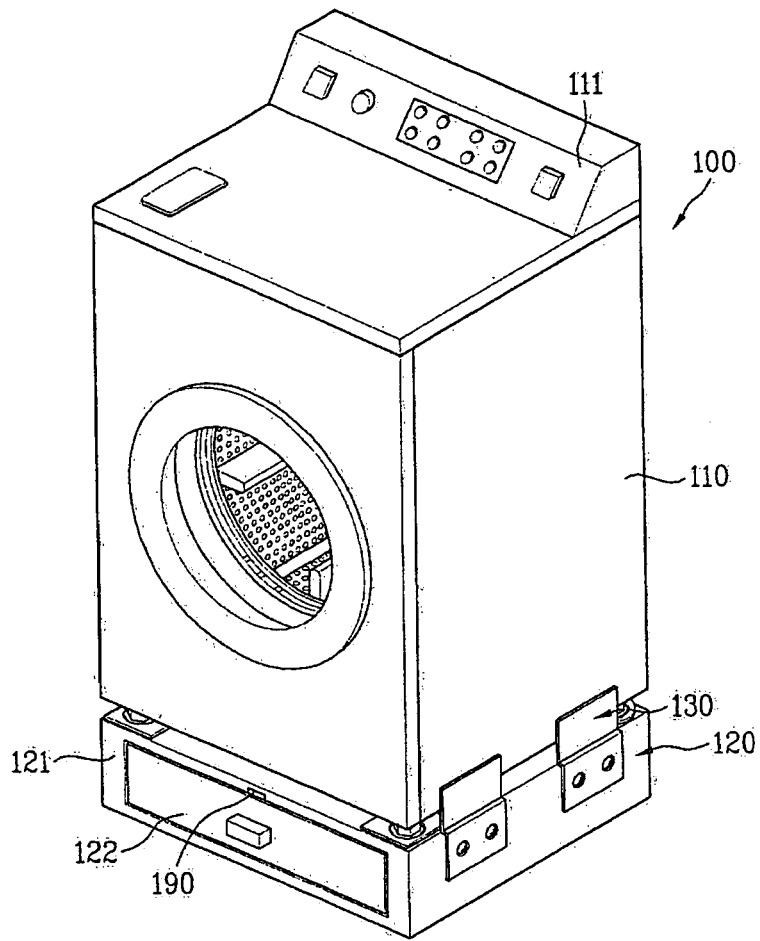



FIG.4

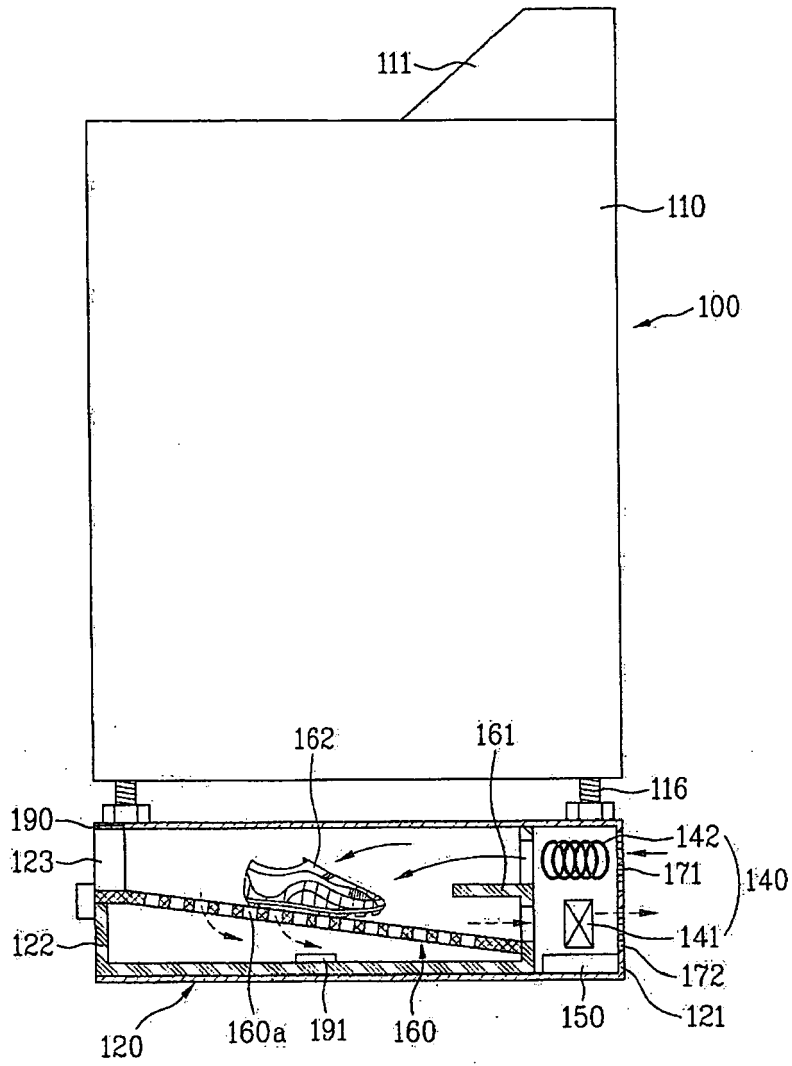
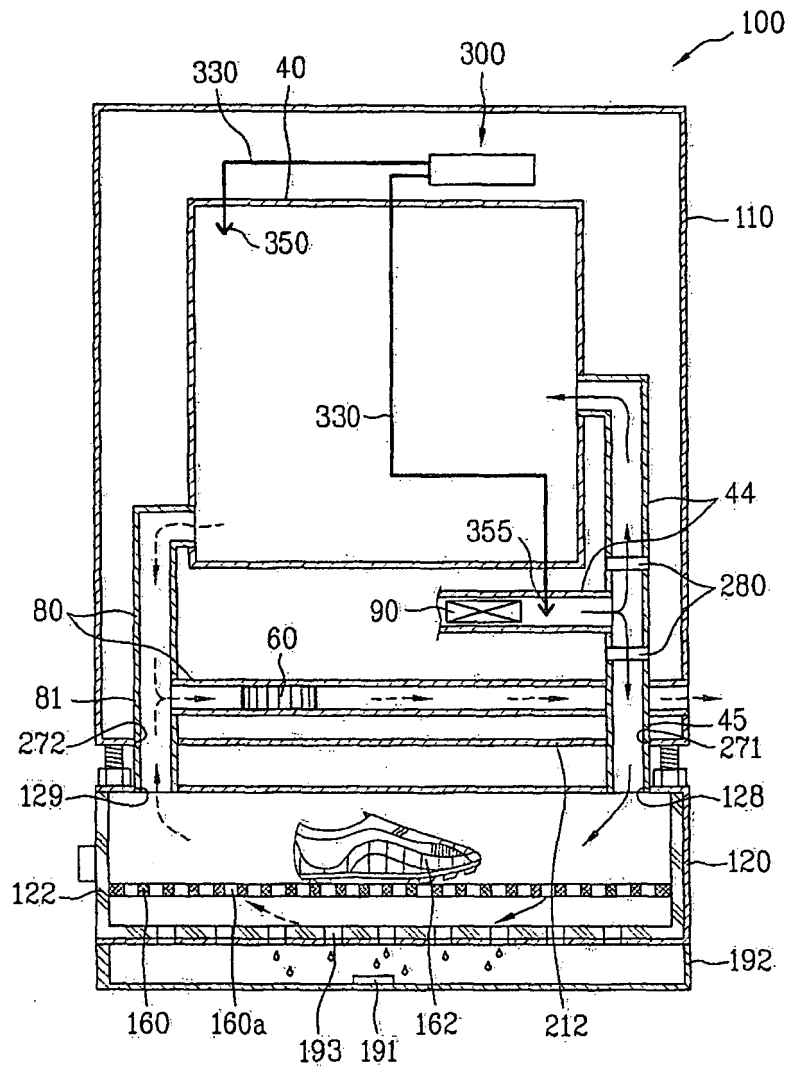

FIG.5



**REFERENCES CITED IN THE DESCRIPTION**

*This list of references cited by the applicant is for the reader's convenience only. It does not form part of the European patent document. Even though great care has been taken in compiling the references, errors or omissions cannot be excluded and the EPO disclaims all liability in this regard.*

**Patent documents cited in the description**

- KR 1020060083384 [0001]